



44<sup>th</sup> IAEE  
INTERNATIONAL  
CONFERENCE  
Riyadh, Saudi Arabia  
4-9 February 2023

# PROCEEDINGS OF THE 44<sup>TH</sup> IAEE INTERNATIONAL CONFERENCE

PATHWAYS TO A CLEAN, STABLE, AND SUSTAINABLE ENERGY

**IAEE**  
International Association for  
ENERGY ECONOMICS

 **KAPSARC**  
مركز الملك عبدالعزيز للدراسات والبحوث البترولية  
King Abdullah Petroleum Studies and Research Center



جمعية اقتصاديات الطاقة  
Saudi Association for Energy Economics

دار جامعة  
الملك سعود للنشر  
KING SAUD UNIVERSITY PRESS







**44<sup>th</sup> IAEE  
INTERNATIONAL  
CONFERENCE**

Riyadh, Saudi Arabia  
4-9 February 2023

**PROCEEDINGS OF THE 44<sup>TH</sup> IAEE  
INTERNATIONAL CONFERENCE**

**“PATHWAYS TO A CLEAN, STABLE, AND  
SUSTAINABLE ENERGY FUTURE”**

© Saudi Association for Energy Economics, 2023

King Fahd National Library Cataloging-in Publication Data

Al-Moneef, Majid

Proceedings of the 44<sup>th</sup> IAEE International Conference/Al-Moneef,  
Majid, Riyadh, 2023

540p; 21cm X 29.7cm

ISBN: 978-603-04-4981-1

1-Energy	2-Conferences	I-Title
621 de	1444/6613	

**L. D. no. 1444/6613**

**ISBN: 978-603-04-4981-1**

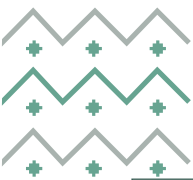
This book is Published by The Saudi Association  
for Energy Economics



جمعية اقتصاديات الطاقة  
Saudi Association for Energy Economics







## Table of Contents

Welcome Message from the IAEE President .....	05
Welcome Message from the SAEE and KAPSARC .....	07

### English Abstracts by Subject Area

1. Petroleum .....	10
2. Natural Gas .....	24
3. Coal .....	42
4. Unconventional Fossil Resources .....	47
5. Nuclear Power .....	55
6. Electricity .....	65
7. Renewables .....	103
8. Energy and the Environment .....	178
9. Energy Efficiency .....	279
10. Transportation .....	302
11. Energy and the Economy .....	330
12. Energy Access .....	394
13. Energy Security and Geopolitics .....	407
14. Energy Investment and Finance .....	428
15. Energy Modeling .....	460

### Arabic Abstracts by Subject Area

1. Petroleum .....	526
2. Energy and the Economy .....	527
3. Energy Investment and Finance .....	529
4. Energy Access.....	530

### Conference Organizers

International Association for Energy Economics (IAEE) .....	534
King Abdullah Petroleum Studies and Research Center (KAPSARC) .....	535
Saudi Association for Energy Economics (SAEE) .....	536

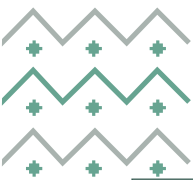
Conference Sponsors .....	538
---------------------------	-----



Table of Contents







## Message from the 2023 IAEE President

Dear authors of the papers received by our IAEE 44th International Conference in Riyadh,

You are what our association is about: exchanging information and ideas, testing hypothesis and reasoning. As a knowledge-based association, we do not support any particular energy interest or take any policy positions; rather, we look after world energy economics as a "state of the world" and progress.

We are very grateful to the King Abdullah Petroleum Studies and Research Center (KAPSARC) and the Saudi Association for Energy Economics (SAEE) for organizing our 44th IAEE International Conference, for the first time in the MENA region, in Saudi Arabia. Without their efforts and hospitality this would not have happened.

However, the treasure is found in your work.

How is the oil and gas industry evolving, and why, what are the key influencing factors? Will the Russia-Ukraine-Europe's shock keep troubling the entire world supply, or progressively stabilize its effects and reduce its impacts?

Are the post-pandemic disturbances here to stay in the global manufacturing and supply chains, or will they be overcome by efforts, reorganization and investments?

What new contributions are Saudi Arabia and the Middle East bringing, currently and in the near future? Be it as leaders in oil and gas, or pioneers in wind and solar, nuclear or green hydrogen?

At IAEE, we are neutral experts, never shy of addressing an issue, not blind in front of problems or difficulties, but always looking first at facts, at reasoning, and methodologies. We all share a scientific ideal: that of a knowledge built on its own logic and verifiable truth. We are open to each other on this reasonable basis.

And this wonderful edition of our proceedings will again show that we are right and that we know how to learn from each other.

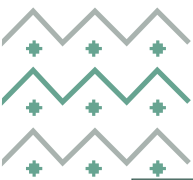
Sincerely,

Jean-Michel Glachant

President of IAEE







## Message from the co-hosts of the 44th IAEE International Conference

On behalf of the King Abdullah Petroleum Studies and Research Center (KAPSARC) and the Saudi Association for Energy Economics (SAEE), it is a pleasure to welcome you to the 44th International Association for Energy Economics (IAEE) Conference, hosted for the first time in the MENA region, in Saudi Arabia. We are grateful to all the SAEE and IAEE officers and members, affiliate leaders, and KAPSARC colleagues who gave their all to make this event a success.

With this edition of the Abstracts of the Conference Proceedings, we look forward to an eventful year ahead. This booklet contains 278 abstracts of the presentations that are organized in 42 concurrent sessions, around relevant topics, such as: oil gas, coal renewables, electricity, nuclear, transportation, energy efficiency, energy and the environment, energy modeling energy security, and energy investment and finance.

Notwithstanding, the events of the past few years have taught us some important lessons. While we witnessed a pandemic in 2020, the year 2021 featured signs of revival with economic upswings in some parts of the world but also post-pandemic global supply chain bottlenecks that impeded the recovery's sure footing, leading to inflation at the year's end.

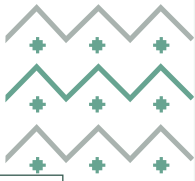
2022 was largely defined by an energy crisis caused by the Russia-Ukraine conflict that ultimately led to energy supply interruptions and economic sanctions. In Europe, gas price hikes hit previously unheard-of peaks of nearly 300 Euro/MWh, but the global oil market remained stable thanks to OPEC's oil market strategy and consistent stabilization efforts.

This means that the role of the oil and gas sector's contribution to a stable economy and, simultaneously, a seamless energy transition, cannot be understated. Saudi Arabia, a responsible energy producer, has long viewed climate action as a chance to provide realistic solutions to a problem that affects us on a global scale.

This year's IAEE conference is one of the Kingdom's vehicles that showcase its leadership in this space and its adoption of a balanced, proactive and positive approach to the energy transition that is holistic, inclusive, and sustainable.

As energy experts we must observe, analyze, and assess global supply chains, consumer welfare, and market mechanisms, with rigorous attention to the implications for energy affordability, energy supply, decarbonization policies, global economic growth and prosperity.





As the conference program confirms, the IAEE community continues to be at the forefront of energy policy analysis, discussion, and debate. Our roles have never been more vital, nor our expertise so needed.

Given the breadth of expertise present today, we are convinced that we can articulate practical solutions for clean, stable, and sustainable energy pathways that engage all stakeholders and result in a smooth energy transition.

We take this opportunity to thank all the authors of the abstracts, the keynote speakers, the panelists and all the attendees. We thank King Saud University Press and its leadership and staff for the relentless work on the publication of the abstracts of the IAEE2023 proceedings.

Lastly, the conference's inclusion of a sizeable number of young energy professionals is the best evidence yet that today's brightest experts can shoulder this important responsibility very ably.

Going forward, we hope that this conference opens a fruitful, continuing dialogue among us ensuring that the 44th IAEE International Conference is our most productive and impactful so far.

Sincerely,

Dr. Majid Al-Moneef & Fahad Alajlan

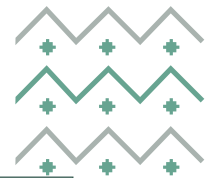






# **English Abstracts by Subject Area**





Petroleum

## *Alternative Fuels for Saudi Cement Manufacturing With Time-Varying Carbon Pricing*

Walid Matar, KAPSARC, Riyadh, Saudi Arabia, [walid.matar@kapsarc.org](mailto:walid.matar@kapsarc.org)

Doaa K. Filali, Princess Nourah bint Abdulrahman University, Riyadh, Saudi Arabia

### Overview

Cement production in Saudi Arabia surged in the first half of the 2010s due to the country's rapid economic development. It has slowed measurably in recent years as economic growth has declined. Still, it ranks among the top-ten countries for existing cement kiln capacity. The Saudi cement industry has relied on crude oil, heavy fuel oil, and natural gas to produce clinker, a key cement ingredient.

The Kingdom is pursuing the reduction of domestic oil use in the industrial, electric power, and water sectors. Energy price reform, as detailed by Saudi Vision 2030, is intended to induce most large-scale consumers of crude oil and diesel to look elsewhere to fuel their electricity generation and industrial manufacturing processes. TDF and petroleum coke are fuels that local cement producers could consider when displacing their liquid fuels use.

In this paper, we examine the prospects for the use of scrap tires and petroleum coke as supplemental fuels in the Saudi cement industry. Moreover, we look at the impact of different carbon pricing schemes on the decisions made by the Saudi cement industry. This paper assesses the effectiveness of policies to encourage the adoption of these alternative fuels in Saudi Arabia.

### Methods

We employ a variant of the cement manufacturing optimization model in the KAPSARC Energy Model. The cement model is mostly described by KAPSARC (2016), with modifications to include tire-derived fuel (TDF), petroleum coke, more pollutant emissions, and carbon pricing in this paper. The optimization is formulated as a linear program that is run in a perfect foresight fashion. Its objective function maximizes the profit of the entire industry. Four regions of Saudi Arabia are represented, allowing for the interregional domestic transfer of cement. The sector may either import product or produce cement for domestic use or exports. The model makes fuel use, other operational and investment decisions to maximize its profit. As such, it takes the central planner approach.

In addition to establishing a reference using the set of current policies, we examine three policy scenarios looking at the use of alternative fuels, the prospects of retrofitting support for cement plants, and easing price controls on fuels. We assess the investment and operational decisions made by the Saudi cement manufacturers, and the resulting emissions profiles for CO<sub>2</sub> and pollutants.

### Results

Some 95 million metric tonnes of TDF are used from 2019 to 2025 if fuel prices are kept the same. Having external financial support for the incremental investment required to use TDF raises its use by a factor of four over the planning horizon. This support does not, however, yield significant reductions in the marginal cost of production. TDF is only used to its full capacity in the Retrofit Support and the Liberalized Fuel Prices scenarios. It is not used when liberalized fuel prices are paired with carbon pricing schemes. Gradual carbon pricing brings about different intertemporal production decisions and large amounts of cement storage compared to the other scenarios. This intertemporal arbitrage is expected from cement producers if governments specify any kind of future gradual reform. Priced at the value at which Saudi exports it, petroleum coke is only used when fuel prices are liberalized.

### Conclusions

Facilitating the use of TDF and petroleum coke would help alleviate the increased cost resulting from energy price reform without a carbon price. The marginal cost of producing one extra tonne of Portland Type I cement would be reduced by about 40% compared to a price liberalization scenario that bars the use of TDF and coke.

All scenarios without carbon pricing produce 340 million tonnes to 380 million tonnes of total CO<sub>2</sub> emissions from 2019 until 2025. The advent of a constant carbon pricing scheme and fuel price liberalization results in 280 million metric tonnes of CO<sub>2</sub>. When both fuel prices are liberalized and a gradual carbon price is in place, 390 million metric tonnes of CO<sub>2</sub> is produced. This is due to the production of large quantities of cement and storing it for future years when the carbon price is highest.

### References

KAPSARC. 2016. "The KAPSARC Energy Model for Saudi Arabia: Documentation of the model build called 'KEM-SA\_v9.16.'" Last accessed July 13, 2021: [https://www.kapsarc.org/wp-content/uploads/2016/11/KEM-SA\\_documentation\\_v9.16.pdf](https://www.kapsarc.org/wp-content/uploads/2016/11/KEM-SA_documentation_v9.16.pdf).





## ***THE CONTRIBUTION OF NATIONAL OIL COMPANIES (NOCs) TO THE ENERGY TRANSITION***

**César Baena, PhD**  
**EM Normandie Business School, France**  
**Professor of Strategy and Director of Post Graduate Programs**  
**+336 59364157**  
[cbaena@em-normandie.fr](mailto:cbaena@em-normandie.fr)

Oil companies are often criticized for not making enough efforts to curb carbon emissions and reduce environmental damage. However, the picture is quite different when analyzing the data on their efforts and strategic actions implemented to facilitate the transition towards renewable energy sources.

The data (S&P Global) suggests that Oil Majors (ExxonMobil, BP, Shell, Chevron, TotalEnergies) fare better than National Oil Companies (NOCs) (Saudi Aramco, Gazprom, NIOC, CNPC, Rosneft, ADNOC, KPC, Sonatrach, QatarEnergy, Pemex, Pdvs) in their efforts to reduce carbon emissions. However, when comparing the enormous reserves and production capacity of NOCs to those of the Oil Majors the impact of these private companies on the energy transition is limited.

Together, the NOCs produce three-fifths of the world's crude and half its natural gas; in contrast, Oil Majors produce just over a tenth -the remaining tenth is produced by a group of large international oil firms-.

NOCs possess two-thirds of the reserves of oil and gas globally. Four of them (ADNOC from the UAE, Venezuela's PDVSA, QatarEnergy and Saudi Aramco) hold enough reserves to continue producing at present levels for the coming four decades.

In the current context where the oil barrel can reach unprecedented heights and where the demand for natural gas is significantly increasing, NOCs have received staggering amounts of cash. Despite this windfall, their record in decarbonization efforts is mostly poor. Overall, according to the energy consultancy Wood Mackenzie, most NOCs are only allocating less than 5% of their capital spending to the energy transition, compared with 15% on average for American and European firms. Moreover, compared to Oil Majors, their record in filing patents for green projects has been disappointingly low.

NOCs vary significantly in their strategies, management, and approaches toward the energy transition. The group includes highly mismanaged companies such as Venezuela's PDVSA or Algeria's Sonatrach as well as professionally run companies such as Saudi Aramco or Norway's Equinor, both of which have implemented ambitious and example-setting strategies to transition to a cleaner energy.

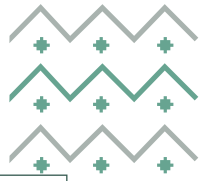
Also, interesting examples in their ambitious efforts toward renewable energies include Malaysia's Petronas, Thailand's PTT and Colombia's Ecopetrol. A case to mention is China's CNOOC and its strategy to peak carbon emissions by 2028 and make sure that non-fossil energy will make up over half its domestic output by 2050.

Another interesting group of NOCs, especially those where oil reserves are diminishing, (eg. UAE's ADNOC), is using the current fossil windfall to move away from dirty energy and invest in clean sources.

There is a key and unresolved tension between the need for NOCs to provide enough revenues for the state (its key shareholder) while implementing sound strategies to decarbonize its activities and comply with ESG principles. NOCs are responding in various ways to this challenge:

- Investing heavily in decarbonization technologies including carbon capture, utilization and storage (CCUS), methane efficiency, zero-emissions production, and hydrogen
- Redesigning business models to include development of renewables as a complement to oil and gas E&P
- Pivoting strategic orientation towards energy-transition goals
- Revisiting their geopolitical scope to curb transaction costs, improve value chains, and reduce exposure to high-risk areas





Another strategic path that NOCs could take is investing in infrastructure such as refineries in state-to-state partnerships. NOCs can use their political clout to develop infrastructure and increase efforts to advance in the decarbonization agenda across borders.

Of critical importance is the impact of technological disruption on the decarbonization strategy of NOCs. Non-fossil fuel-based technologies such as nuclear fusion, algae-based biofuels, fuel cells, to name a few, would have a positive impact on reducing carbon emissions, be in alignment with the circular economy and comply with the Paris-agreement goals of limiting yearly carbon emissions.

The focus of this research is to analyze NOCs efforts, both technological and strategic, in easing the transition to low-carbon energy sources. The current context is highly propitious as NOCs, benefiting from the price windfall, have the means to put the energy transition at the center of their strategic development and invest in technology innovations for E&P activities as well as in various non-fossil fuel projects.

This paper will look at data from selected NOCs and analyze their strategic actions to favor the transition to lower carbon-intensity activities. The analysis will specifically highlight the key role of Saudi Aramco in this transition, through a discussion of its research and development program, its carbon capture technology, and its large investment in the green-hydrogen futurist city of Neom.

#### References

Haytayan, L., Heller, P. et al. "National Oil Companies and Energy Transition in the Middle East and North Africa". Natural Resource Governance Institute. February 2021.

"How Can Governments, Oil and Gas Enterprises, and Research Institutions Collaborate to End Routine Gas Flaring?" KAPSARC, The World Bank. April 2022

Johnston, R., Blakemore, R., Bell, R. "The Role of Oil and Gas Companies in The Energy Transition". Atlantic Council. January 2020.

Manley, David and Heller, P. "Risky Bet National Oil Companies in the Energy Transition". Natural Resource Governance Institute. February 2021.

"National Oil Companies: strategies for the energy transition". Wood Mackinsey. March 2022.

"The Oil and Gas Industry in Energy Transitions Insights from IEA analysis". IEA. January 2020.

"10 Cleantech Trends in 2022 Technologies to reduce emissions and confront climate change". HIS Markit, 2022.

Selected oil company annual reports.





[POSTER TITLE]

***Economic Analysis of Sustainable Hydrogen Production from Thermolysis and Electrolysis Relying on Nuclear Power***

Ahmed E Salman, Radiation Eng. Dept. , NCRRT, Egyptian Atomic Energy Authority, Egypt, +201000480510, [eng.ahmed8810@yahoo.com](mailto:eng.ahmed8810@yahoo.com)

Ashraf Aboshosha, Radiation Eng. Dept. , NCRRT, Egyptian Atomic Energy Authority, Egypt

**Overview**

Climate change threatens people with food and water scarcity, increased flooding, extreme heat, disease, and economic loss. The World Health Organization (WHO) calls climate change the greatest threat to global health in the 21st century. Even if efforts to minimize future warming are successful, some effects will continue for centuries. Green hydrogen is indispensable to climate neutrality. It features in all eight of the European Commission's net zero emissions scenarios for 2050. Hydrogen can be produced from diverse energy resources, using a variety of process technologies. These energy resource options include fossil, nuclear, and renewables. Hydrogen is a highly efficient and environmentally clean fuel and can be produced in a variety of ways. Currently, the most common methods are water electrolysis and thermochemical cycles. It is clear that the leading method for hydrogen production in the future is nuclear energy. In the article, Pressurized Water Reactors (PWR) integrated with Solar Power Concentrators (SPC) are studied to produce hydrogen. The main objective is to reduce carbon dioxide emissions and raise the economic viability of nuclear reactors. Throughout this research, the high thermal energy generated from the PWR assisted by the SPC is used to generate hydrogen for the sustainable development of smart cities. Where comparison was made between hydrogen production by water splitting electrolysis and the thermolysis by Cu-Cl cycle using 300 megawatts of electricity, which is a quarter of the product of the VVER-1200 reactor. The proposed PWR- SPC system provides high energy efficiency, improved safety, and secured energy.

**Methods and Results**

This work investigates how to produce hydrogen using nuclear power. Thermochemical water splitting uses high temperatures from concentrated solar power or from the waste heat of nuclear power reactions to produce hydrogen and oxygen from water. This is a long-term technology pathway, with potentially low or no greenhouse gas emissions. Currently, the most common methods are water electrolysis and thermochemical cycles. It is clear that the leading method for hydrogen production in the future is nuclear energy. In the article, Pressurized Water Reactors (PWR) integrated with Solar Power Concentrators (SPC) is studied to produce hydrogen (Figure 1). Throughout this research, a case study of a VVER-1200 reactor is proposed where high thermal energy but with limited temperature is generated. SPC is used to increase the temperature to reach the target values. The Cu-Cl cycle, with a thermodynamic limit of 500 °C, has been proposed as a candidate for integration with the VVER\_1200 nuclear reactor. The Cu-Cl Thermochemical water splitting cycle has special working conditions that must be compatible with the studied system. Thermodynamic analysis of the reaction based on the equilibrium conversion and extent of reaction. Detailed thermodynamic modeling is studied to calculate the amount of heat needed to execute the chemical reactions which is 310.8 kJ/mol. Finally, the simultaneous production of hydrogen and power from nuclear plants will be reviewed from a technical point of view, and its future potential impact on the hydrogen economy will be evaluated. The Levelized Cost of Energy (LCOE) Approach is studied to evaluate the processes.

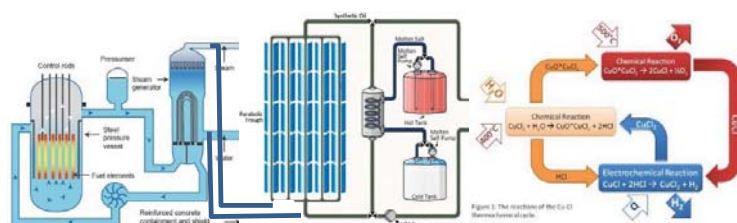


Figure 1. PWR- SPC based Cu-Cl Hydrogen Cycle

In order to produce 1 kg of hydrogen, 500 moles of each reactant should be used; we need 200 kg of  $cucl_{aq}$  and 9 kg of water. Other products of the cycle may be economically beneficial such as 8 kg of oxygen. To calculate the



economic feasibility of hydrogen production via the nuclear industry precisely, we should take all products into consideration. In this study, 300 MWe from the reactor is used in the thermal phase (approximately 803 MWth) and the temperature is 320°C. The proposed system run at a temperature of 500°C. So, a molten-salt auxiliary cycle is proposed to be installed in the reactor's secondary cycle without conducting any modifications in the reactor's design. The auxiliary system is designed to increase the temperature to the required 500°C. The thermal energy should be translated to the auxiliary system also. The proposed system is studied to generate 14 tons of Hydrogen, and 112 tons of Oxygen.  $7 \times 10^6$  moles of each reactant should be used. In a weight study reactants of 126 tons of water and 2800 tons of  $cucl_{aq}$  should be used as reactants. The net required energy to complete the reactions equals 310.8 kJ/mol which was calculated using a designed thermodynamic model. On the other hand, a typical seawater reverse osmosis plant can be used also, however it consumes 3:10 Kw.hr of electric energy to produce one cubic meter of fresh water.

In this study, parabolic trough Collector is used for the SPC plant. Molten fluoride salt type LiF-NaF-BeF<sub>2</sub> with molar composition of 31-31-38 is used because of its low melting temperature (315°C) and high boiling point temperature (>1000°C). Therefore we can use it to transfer heat in high temperature rates without any problems. Figure 2, represent a simple-completed model of the SPC plant. Finally and after calculating the energy, flow rates, losses, and solar calculations using LS-2 parabolic trough solar collectors, we can obtain the real value of the produced thermal heat in the plant. So, the total number of concentrators can be calculated, which contains 2430 branch, where each branch contains 18 modules in this study. The concentrators will be used to increase the temperature of the Molten-salt fluid up to 500°C as a crucial step to produce hydrogen using thermolysis.

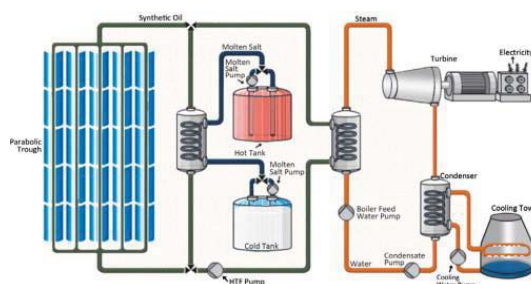


Figure 2. SPC-Model.

## Conclusions

The hydrogen economy is a progressive multi-decadal project which is gradually in transition to the marketplace and is expected to be fully commercialized within a decade. Electrolysis is a promising option for hydrogen production that uses electricity to split water. However, green Hydrogen is still a high cost to generate using electrolyzers. Thermochemical water splitting cycles for hydrogen production are being investigated for more than fifty years as a long-term, large-scale hydrogen production method. In this study, the copper-chlorine cycle (Cu-Cl cycle) is used for the production of hydrogen. Cu-Cl cycle is promising in terms of hydrogen production cost and capability of integration with relatively low-temperature industrial waste heat. Cu-Cl family of thermochemical cycles are highly regarded as promising options for integration with nuclear reactors due to the high efficiency and capability for integration. A Comparison between Cu-Cl thermochemical cycles and Electrolyser is performed in this study from energetic, energetic, economic, and environmental points of view. Thermochemical cycles are not yet seen as cost competitive compared to the conventional methods while a proper integration with concentrated solar or nuclear reactors is necessary for further improvement. Finally, considering that LCOE for every kWh thermal energy produced by the PWR is approximately 2 cents. Hydrogen production rate should be taken into consideration where just 55.63 kWh is enough in this study to produce 1 Kg of Hydrogen and 8 kg of Oxygen. The study results that the cost of Hydrogen is aimed to be approximately less than \$1/KgH<sub>2</sub>. However, the cost of hydrogen can range from ~\$4 to \$6/kg-H<sub>2</sub> with electrolysis.

## References

1. International Atomic Energy Agency, Hydrogen Production Using Nuclear Energy, Iaea Nuclear Energy Series No. Np-T-4.2, IAEA, Vienna (2012)
2. Fino, D. "Hydrogen production in conventional, bio-based and nuclear power plants." In Advances in Hydrogen Production, Storage and Distribution, pp. 85-122. Woodhead Publishing, 2014
3. A Hydrogen Strategy for a Climate-neutral Europe (European Commission, 2020).
4. Hydrogen Economy Outlook: Key Messages (Bloomberg L.P., 2020).
5. The Future of Hydrogen (IEA, 2019).
6. Sorgulu, Fatih, and I. Dincer. "Cost evaluation of two potential nuclear power plants for hydrogen production." International Journal of Hydrogen Energy 43, no. 23 (2018): 10522-10529





Petroleum

## ***IMPACT OF SUSTAINABLE ENERGY TRANSITION IN TRANSPORTATION SECTOR ON THE NATIONAL OIL COMPANIES OF EMERGING ECONOMIES - A CASE STUDY OF ONGC OF INDIA.***

Athreya Cheppela, +919490722295, ONGC, University of Groningen, a.cheppela@student.rug.nl  
Dr. M. Mulder, University of Groningen, machiel.mulder@rug.nl

### **Overview**

Sustainable Energy transition in Transportation (SET) is shifting away from petroleum-based fuels in mobility. Transportation is a major contributor to the global green-house gas emissions and a key sector in achieving climate change mitigation targets. SET impacts various sections of economy, particularly oil and gas producers are highly affected, due to the fall in the demand of oil and gas. However, the progress of SET is dissimilar among the countries, growing economies like India are expected to be the demand centres for the petroleum fuels in coming decades. For the low-cost oil and gas suppliers like MENA countries, India will become a major market, to compensate the loss of demand in the erstwhile markets (Dale & Fattouh, 2020) (Luciani & Moerenhout, 2020). National Oil Companies (NOC) in developing economies like Oil and Natural Gas Corporation (ONGC) of India, a fortune 500 company, will face the increased competition. There will be a conflict with the national governments who give energy security high priority over commercial interest of NOCs and to some extent over the fall in the pay-outs from NOCs to exchequers. Even in moderate growth of SET, price volatility and challenges to find new discoveries, necessitates the shift in strategy. For higher oil & gas price scenarios, the balance of payment pressures of their owner nations will make NOCs to find new and difficult reserves, these assets will face the threat of stranding in future downturns, nevertheless SET will make permanent impacts unlike general commodity cycles. Furthermore, sooner or later low resource base nations also give priority for SET which further shrinks the oil & gas market.

Present study focuses on strategic implications of SET on the ONGC's competitiveness, strategic position of ONGC and strategic options available to the company. ONGC's strategic positions is compared with that of CNPC (China National Petroleum Corporation) and KNOC (Korean National Oil Corporation). This study will be useful for the strategic planning of NOCs. Literature on strategic management of NOCs focuses mainly on the implications of energy transition on NOCs of major oil producing nations and their social contract obligations. Studying the impacts on NOCs of energy importers will be a useful addition to the strategic management literature as well as climate change and energy literature, present study is expected to be a significant contributor in that effect.

### **Methods**

Scenario analysis is used to find drivers and inhibitors of SET in India and around the world. As the exact quantitative projections are impossible to make, one can get direction of growth from the scenario analysis. Projections vary among various organisations, comparisons can be made for the possible impacts on the case under study. Company's prospective plans are analysed in the context of SET for the coming decades. Strategic position as well as strategic options in the low-price regime are analysed in grounded theory methodology. The NOCs need to adopt strategies both for improvement in their oil & gas business as well as greening their portfolio. So, the strategies both for oil & gas business as well as diversification into green business are taken into consideration. As projections SET growth are different among the various studies, impacts are modelled for ONGC in three different scenarios namely, 1. Business as usual- current EV growth 2. Low EV growth in India and High EV growth in rest of the world. 3. High EV growth in India and rest of the world. For each scenario a simple merit order supply model for India is made, where ONGC and low-cost competitors are main competitors. Furthermore, quantitative prediction is modelled by applying various scenarios of the strategic options on the financial outcomes for ONGC. Data is obtained from the primary, secondary literature, which is available in public domain, financial data is taken from the annual reports of the company.

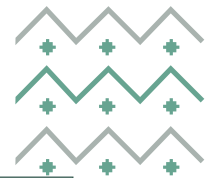
### **Results**

#### **Scenario analysis of impacts on ONGC:**

ONGC's profits are highly correlated with the crude oil price as oil market are liberalised and Gas prices are still under administrative control in India. ONGC's capital expenditure & production volumes are almost constant over the years. Worldwide oil demand decline is dependent on the growth of SET, however, impacts on ONGC are analysed in three different scenarios,

1. In the business-as-usual scenario India's SET (Electrical vehicles (EV) can be used as a proxy to SET) growth is moderate compared to regions like Europe. ONGC's profits will stay in accordance with the growing oil demand and price of oil. Strategies improve oil & gas business are important in this regard. As per the concept of "stock effect" the marginal cost will increase with cumulative production (Cynthia & Gernot, 2007), marginal cost of new barrel addition will rise,





which is a challenge to achieve ONGC's targets of doubling the production (ONGC target for 2040). 2. In Low EV growth in India and High EV growth in rest of the world scenario, India's oil demand grows but due to the fall in demand in the world market, low-cost producers to save their volumes in the world market, will shift to Indian market, which will reduce the oil prices. Profits of ONGC will decrease because ONGC's supply stays at the same level, as it struggles to increase the supply. Company must find low-cost reserves and reduce the cost of production to protect itself in the low-price environment. 3. In High EV growth in India and in rest of the world scenario, Oil demand will get drastically reduced, India will show some demand, ONGC keeps its market share. International supply will compete for the rest of the market share, which ONGC is unable to serve. Indian demand reduction will result in lower price level from the business-as-usual-level but the competition with the international supplies will further reduce price levels, if low-cost producers try to prefer quantity over prices to keep their market share intact. ONGC needs to protect its market share from the imports. Low oil prices bring relief to government but ONGC will see its balance sheet shrink, this scenario necessitates ONGC to diversify towards green energy.

**Strategic position & options of ONGC and comparison of selected NOCs:**

ONGC is exploring collaborations with various firms and academic institutions to progress in its two-part strategy in oil & gas and diversification (Ugal, Nishant, 2021). ONGC profits are highly co-related with oil price, which is well recognised, but the strategies for low oil price scenarios are not made as a thrust area. Global analytical firms give much importance of impacts of low oil prices on oil companies and proposes strategies (Filipe, Scott, Kassia, Giorgio, & Pat, 2020) (Christopher, Scott, & Jannik, 2016). ONGC, CNPC and KNOC face similar issues, they will face growing challenges in fulfilling their core mandate as domestic resources gradually decline, and the energy transition poses new threats. Their strategies are also similar, like efficiency improvement, adaptation of technologies. A limited resource base and relatively high production costs at home suggest that the NOCs will have to look abroad. These NOCs may have to compete among themselves in overseas expansion, However, the increased competition may drive valuations of assets and increase the threat of disadvantaged assets. These NOCs have not announced dramatic strategies for diversification, but are taking steps to align with state goals. NOCs need to cut their own emission(scope1&2) before making any additions to their portfolios, this will help in capital access. Policy analysis of respective governments do not suggest that the state will support dramatic moves by the NOCs away from their core business. NOCs need to build up campaign to reposition their brands in green energy by creating narrative and with minimum resistance approach with the respective governments.

**Strategic options:** For low oil price regimes, some of the following strategic options can be explored. Business model innovation like partnerships with resource rich NOCs, as the resource NOCs will compete for the Indian market, they are exploring long-term partnerships with Indian firms (Bhatt, Mollet, & Roychoudhury, 2019). For ex. ONGC, in partnership with cheaper producers can switch crudes in response to prices for its refineries. Volume improvements through improved efficiencies, technology adaptation, digitalisation (WEF & Accenture, 2017). Accelerated monetisation of proved and unconventional assets, to avoid cost over-runs and the high-cost projects vulnerable in the era of low oil prices (Ugal, Nishant, 2022). Furthermore, for GOI has concern over the losing forex, pressurises ONGC. High priority should be given to bring the barrels on-line from the explored fields. Windfall profits, from the heyday should be earmarked for the said purpose. Unconventional resources should be developed quickly. The natural gas seen as a bridge fuel for the growing economies, so far, the development of gas economy not fruitful in India. Low price realization of gas for oil & gas companies discouraged the development of gas fields. Liberalization of gas prices and marketing reforms are right steps in the direction of development of gas economy (CCEA, 2020), which will give strategic advantage to ONGC to substitute losing revenue from oil. Diversify into green technologies associated to oil & gas as initial step for diversification, venturing into green energy vectors in which ONGC will have an advantage, like Hydrogen, CCUS (carbon capture utilization and storage), offshore wind etc. with the advantage of pipeline network, offshore expertise and experience in big projects. Remote locations assets (stranded gas) can be brought on line by developing small power generation projects, which in turn will give an advantage of experience in developing green power generation. A simple model is made for the returns on capital employed for ONGC with various scenarios of oil price decline and percentage diversification. The model gives the result that due to lower returns from green energy, high fall in the oil price has huge impacts even in high diversification, faster diversification in moderate fall in the price will reduce the impacts of oil price drop.

**Conclusions**

Sustainable energy transition impacts oil and gas producers worldwide. National oil companies of oil importing growing economies face dilemma of energy security for their nations and increasing value from diversification. NOCs face constraints from the government policies. Due to the inefficiencies and increased competition in the sustainable transition, ONGC's profitability will be highly co-related with the path of EV growth in India and the world. This study depicts ONGC's market competitiveness in the various scenarios and focusses on the strategic position and plausible options in comparison with similar NOCs. The energy transition is a non-linear systemic shift, impacts of which will be visible after formation of critical mass, so the strategies should look beyond the current necessities. The present study shall make an addition to the strategic management literature and public sector enterprise literature. There is a scope for future studies by improving the model in the present study with additional variables and deep data analytics.





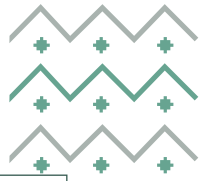
## References

- Arun, P. (2021, August 16). ONGC well prepared for changing environment in oil sector: Alka Mittal. *Gharwal Post*.
- Bazzana, A. M. (2016). *Driving Down Costs in a Digital Oil and Gas Future*. Toptal.
- Beck, C., Kar, J., Hall, S., & Olufan, D. (2021, March 10). *How oil and gas is navigating the energy transition*. Retrieved from McKinsey: <https://www.mckinsey.com/industries/oil-and-gas/our-insights/the-big-choices-for-oil-and-gas-in-navigating-the-energy-transition>
- Ben Cahill. (2022). *National Oil Companies Leaning into the Energy Transition*. Center for Strategic & International Studies.
- Bhatt, Y., Mollet, P., & Roychoudhury, J. (2019). *India's Oil Imports: Achilles' Heel or Economic Javelin*. KAPSARC.
- CCEA. (2020). *Cabinet approves 'Natural Gas Marketing Reforms'*. PIB.
- Christopher, H., Scott, S., & Jannik, W. (2016). *The oil and gas organization of the future*. Mckinsey.
- CNPC. (2020). *Annual Report*. CNPC.
- Cynthia, L., & Gernot, W. (2007). Steady-state growth in a Hotelling model. *Journal of Environment and Economic Management*, 68-63.
- Dale, S., & Fattouh, B. (2020, May 22). *Peak oil demand and long-run oil prices*. Retrieved February 5, 2022, from [www.bp.com](http://www.bp.com): <http://www.bp.com>
- Damon, E. (2021, 09 24). Petroleum ministry tells India's ONGC to sell oil fields and find foreign partners. *Energy Voice*.
- Filipe, B., Scott, N., Kassia, Y., Giorgio, B., & Pat, G. (2020). *Oil and gas after COVID-19: The day of reckoning or a new age of opportunity?* Mckinsey.
- Geert, V., & Derk, L. (2012). *Governing the Energy Transition: Reality, Illusion or Necessity?* Taylor & Francis.
- Henk, V., Frans, A., Van, D. B., & Heij, K. (2017). Know Your Business Model. In V. Henk, A. Frans, D. B. Van, & K. Heij, *Reinventing Business models*. Oxford.
- KNOC. (2022). *Better Energy for*. KNOC.
- Luciani, G., & Moerenhout, T. (Eds.). (2020). *When Can Oil Economies Be Deemed Sustainable?* Springer Singapore. Retrieved February 6, 2022
- Margarethe, F. W., & Joseph, B. B. (2017, March 29). Corporate or Product Diversification. *Oxford encyclopedias-Business and Management*.
- Ministry of Finance. (2021). *Policy on strategic disinvestment*. Press Information Bureau.
- MOPNG. (2015). *MoU with Pan IIT by ONGC for Exploration of Hydrocarbon*. Press Information Bureau.
- MOPNG. (2020). *Digitalization Roadmap for Indian Exploration and Production (E&P) Industry*. Ministry of Petroleum and Natural Gas.
- MOPNG. (2022). *ONGC inks MoU with Norway's Equinor to collaborate on E&P, clean energy*. PIB.
- ONGC. (2021). *Annual Report*.
- ONGC. (2021). *Annual Report-20-21*. Retrieved February 5, 2022, from ONGC - Oil and Natural Gas Corporation Limited: <http://www.ongcindia.com>
- ONGC. (2022). *ONGC signed a MoU with Chevron New Ventures PTE Limited*.
- ONGC. (2022). *Subsidiaries*. ONGC.
- Perkins, R. (2019). *State oil companies evolve to face the future*. S&P Platts.
- PIB. (2018, January 21). Acquisition of HPCL by ONGC. *Press Information Bureau*.
- Pratik, D. (2020). Analysing India's Open Acreage Licensing Policy: Problems and Perspectives. *Journal of World Energy Law and Business*, 483-489.
- Rai, V. (2010). *Adapting to Shifting Government Priorities: An Assessment of the Performance and Strategy of India's ONGC*. Retrieved from <http://dx.doi.org/10.2139/ssrn.1594998>
- Ugal, N. (2021, December 6). ONGC seeks international partners for offshore exploration. *Upstream*.
- Ugal, Nishant. (2022, January 4). Deep-water challenge: ONGC faces fresh delays at \$5bn Indian development. *Upstream*.
- WEF, & Accenture. (2017). *Digital Transformation Initiative Oil and Gas Industry*. World Economic Forum.



Petroleum





## CO<sub>2</sub> EMISSIONS, FINANCIAL INCLUSIVENESS AND ECONOMIC GOVERNANCE

Jihan Bousrih, Economics Department College of Business and Administration Princess Nourah bint Abdulrahman University, +966 580094511, [jsbousrih@pnu.edu.sa](mailto:jsbousrih@pnu.edu.sa)

Fatma Mabrouk, Economics Department College of Business and Administration Princess Nourah bint Abdulrahman University, +966 554493204, [fmmabrouk@pnu.edu.sa](mailto:fmmabrouk@pnu.edu.sa)

Hela Borgi, Accounting Department College of Business and Administration Princess Nourah bint Abdulrahman University, +966 590940778, [haborgi@pnu.edu.sa](mailto:haborgi@pnu.edu.sa)

Mohamed Mehdi Mekni, Faculty of Law, Economics and Management Sciences of Jendouba University of Jendouba, +966 544364894, [mm.mekni@gmail.com](mailto:mm.mekni@gmail.com)

### Overview

In this paper, we examine the effect of co<sub>2</sub> emissions and economic governance on financial inclusiveness in selected African countries from 1996 to 2020. It also investigates the moderating role of economic governance on the association between co<sub>2</sub> emissions and financial inclusiveness. We collected five-year average data from various sources such as the World Development Indicators and the World Governance Indicators. Economic governance is measured by two dimensions: government effectiveness, regulation quality. The financial inclusiveness variable reflects the depth, access, and efficiency of financial institutions and markets.

### Methods

For the analysis, we use the Generalised Methods of Moments (GMM) model. The use of this model is motivated by several reasons (Tchamyou, 2019a). The first condition is related to the number of cross-sections that exceed the number of periods within each cross-section. The research is dealing with 49 countries for a period of 24 years (1996-2020). Second, the independent variable is persistent because its correlation with its first lag is high. Third, cross-country differences are taken on board given the panel nature of the dataset. Fourth, endogeneity is addressed because simultaneity or reverse causality are challenged with an instrumentation process.

The following equation in level 1 presents the GMM estimation used in this paper:

$$FI_{i,t} = \alpha_0 + \alpha_1 FI_{i,t-1} + \alpha_2 CO2_{i,t} + \alpha_3 GOV_{i,t} + \alpha_4 CGOV_{i,t} + \sum_{h=1}^2 h X_{h,i,t} + \varphi_i + \delta_t + \varepsilon_{i,t}$$

Where  $FI_{i,t}$  represents financial inclusiveness of country  $i$  in period  $t$ ,  $\alpha_0$  is the constant, CO<sub>2</sub> is the co<sub>2</sub> gaz emissions, GOV enclose the economic governance indicators, CGOV symbolizes the interaction between CO<sub>2</sub> gaz emission and economic governance measures. The vector X represents control variables ( technology and infrastructure indicators).  $\delta_t$  is the time-specific constant,  $\varphi_i$  is the country-specific effect and  $\varepsilon_{i,t}$  the error term.

### Results

Our results show that economic governance regulates co<sub>2</sub> emissions to have a positive impact on financial inclusiveness in African countries. In fact, the government effectiveness dimension positively impact the financial inclusiveness and this effect is strengthened by the interaction with co<sub>2</sub> emissions. For the regulation quality dimension, the same effect is observed. We also find that infrastructure and technology positively impact financial development.

### Conclusions

Our results can potentially assist regulators and policy-makers in achieving Sustainable Development Goal 13 "Climate action". Our findings will offer more motivations for regulators around the world to reduce co<sub>2</sub> emissions and improve their economic governance as it help countries in developing their financial markets.



## References

Asif Razzaq, Tahseen Ajaz, Jing Claire Li, Muhammad Irfan, Wanich Suksatan(2021), "Investigating the asymmetric linkages between infrastructure development, green innovation, and consumption-based material footprint: Novel empirical estimations from highly resource-consuming economies",Resources Policy,Volume 74.

Boqiang Lin, Stephen Agyeman (2021), "Impact of natural gas consumption on sub-Saharan Africa's CO2 emissions: Evidence and policy perspective", Science of The Total Environment,Volume 760.

Fengsheng Chien, Ahsan Anwar, Ching-Chi Hsu, Arshian Sharif, Asif Razzaq, Avik Sinha (2021), "The role of information and communication technology in encountering environmental degradation: Proposing an SDG framework for the BRICS countries", Technology in Society,Volume 65.

Hanghang Zheng, Xia Li (2022), "The impact of digital financial inclusion on carbon dioxide emissions: Empirical evidence from Chinese provinces data", Energy Reports,Volume 8.

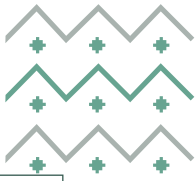
Usman Mehmood (2022), "Contribution of renewable energy towards environmental quality: The role of education to achieve sustainable development goals in G11 countries",Renewable Energy, Volume 178.

Tchamyou, VS, Asongu, SA, Odhiambo, NM (2019a), "The role of ICT in modulating the effect of education and lifelong learning on income inequality and economic growth in Africa", African Development Review 31(3): 261–274.

Yunpeng Sun, Ozlem Ates Duru, Asif Razzaq, Marius Sorin Dinca (2021), "The asymmetric effect eco-innovation and tourism towards carbon neutrality target in Turkey", Journal of Environmental Management,Volume 299.







## ***LONG-TERM OIL PRICES: PEAK DEMAND VS. DECLINING SUPPLY***

Evonne Tan, Saudi Aramco, [evonne.tan@aramco.com](mailto:evonne.tan@aramco.com)

### **Overview**

Stimulus packages, which had an impressive focus on climate, implemented by governments to rescue the economy from destruction brought about by COVID-19 and the Russian invasion of Ukraine in February 2022 have contributed to the acceleration of energy transition in key energy consuming nations. Along with it is an implied peak oil demand in the foreseeable future. The concept of peak demand has been raised numerous times, even pre-COVID-19. In 2018, Spencer Dale (BP's chief economist) and Bassam Fattouh (Director of OIES) said "The significance of peak oil demand is that it signals a shift from an age of perceived scarcity to an age of abundance". So, what does this mean for oil supply, and consequentially oil price, in the long term? The natural assumption would be that once demand peaks, there will be a surplus of supply resulting in declining oil prices. But will that really be the case? The objective of this paper is to take a closer look at the fundamentals and factors that will shape future oil supply and price.

The conclusion from this paper is that long-term oil price support is essential given the need for continued greenfield investment, even in a climate friendly scenario, as the rate of fundamental oil supply decline exceeds the rate of demand decline. Downside risks to future supply due to increasing cost and declining oil and gas (O&G) investments, which will be exacerbated by energy transition, could in turn provide upside to long-term oil price. Steep withdrawal of investments from the upstream sector that is not aligned with global oil demand trajectory, will result in gaps in demand-supply that trigger high and volatile oil prices.







## Energy transition is no longer the same idea it used to be

Dr Sami Alnuaim, 2019 President of the Society of Petroleum Engineers International, Energy Columnist and Social Media Energy Advocate. Dhahran Saudi Arabia, Neaimsa@yahoo.com

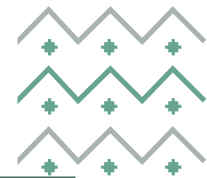
### Abstract

Since the beginning of the Industrial Revolution, almost two centuries ago, the economic growth and human prosperity indices have been directly linked to global energy security (1). Since then, the global energy scenario has been dominated by fossil fuel, currently representing more than 80 percent of the global energy mix, with oil and gas reaching almost 53-55 percent (2). The global energy demand has also been rising proportionally to the micro and macro-economic growth and human prosperity (1). With it, Methane and Carbon Dioxide emissions have been rising, inducing a global environmental and health challenges. Today's definition of Energy Transition is calling to stop investment in oil and gas exploration & development without offering any reliable and sustainable energy alternatives, imposing a huge economic, geopolitical and social threats, putting the unprecedented economic, human prosperity and life style improvement witnessed in the 20<sup>th</sup> and 21<sup>st</sup> centuries at high risk. Adding to this, the world needs more energy to support the must-to-grow global economy, social development and global energy access, especially in poor high populated geographical areas such as Africa and South East Asia (3). Today's Energy Transition concept, driven mainly by extreme environmental agenda, combined with the unrealistic petroleum forecasts studies (4) projecting incorrect oil-demand peak have resulted into the current energy crises in Europe and high global energy prices. Hence, promoting the change of the current Energy Transition's definition to a new definition such as Energy Advancement or Energy Enhancement is important. This new definition calls for all energy sources, with no exception, to grow and reduce their environmental footprint, where reaching net-zero Methane & CO<sub>2</sub> emissions become a must. To solve the current and similar future energy crises, the world must develop and implement a road map to implement this new Energy Advancement strategy using practical and just policies, technology, best practices and effective energy-conservative social behavior. Through this new definition, a new global Energy Security and Energy Sustainability models need to be developed and implemented. The road map must be supported by significant emission reduction investment and multi large-scale initiatives including Carbon Capture, Gas in Power, Renewables in Power, Hydrogen, Energy Efficiency, Carbon Circular Economy, Crude to Chemicals, Energy Conservation, Social Behavior, Afforestation and Deforestation-Control. There is also a need to promote more constructive global energy dialogue between current energy producers and consumers (internal and external stakeholders) instead of the current repulsive energy debate. Other emitting industries that currently contribute to the global Carbon and Methane emissions must be included in the dialogue and accountability. Last, promoting more international R&D and technology-development collaboration is evident.



Petroleum





## ***A PANEL VAR ANALYSIS OF OIL SUPPLY AND DEMAND SHOCKS AND MACROECONOMIC PERFORMANCE: THE CASE OF GULF COOPERATION COUNCIL COUNTRIES***

**Lead and corresponding author:** Youssef Saidi  
Gulf Monetary Council  
Riyadh 11441, Saudi Arabia  
Email: [YSaidi@gmco.int](mailto:YSaidi@gmco.int)

**Second author:** Atef Saleh Alrashidi  
Gulf Monetary Council  
Riyadh 11441, Saudi Arabia  
Email: [AAlrashidi@gmco.int](mailto:AAlrashidi@gmco.int)

### **Overview**

This paper empirically examines the symmetric and asymmetric impact of oil price shocks on the economic performance of Gulf Cooperation Council countries (Bahrain, Kuwait, Oman, Qatar, Saudi Arabia and United Arab Emirates). The study is carried out using the panel vector autoregression (P-VAR) framework and has focused on the causal relationships between real oil crude prices, real gross domestic product (GDP) of GCC countries, real GDP of GCC trading partners, real fiscal balance, inflation and real interest rate over the period 1980-2019. To assess the asymmetric effect of demand-driven and supply-driven oil price shocks on the key macroeconomic variables of GCC countries, we estimate the P-VAR model in two versions using different specifications for oil price shocks. The first one was symmetric (all oil price shocks) and the second was asymmetric discriminating oil-supply disturbances (Oss) from oil-demand shocks (Ods). Based on the estimated two versions of P-VAR model, the impulse response functions (IRFs) were computed using the orthogonalized disturbance from the moving average version of each P-VAR model.

The IRFs obtained from the symmetric version of P-VAR model (Baseline specification) indicate that positive oil price shocks (OP) lead to significant increases of fiscal balance (FB) in the short/medium-term and imports (IMP) in the short-term in the sense that GCC countries' oil revenues are partially recycled into demand for goods and services.

Trading partners' output gap shock (POG), representing the foreign demand addressed to GCC countries, has positive effect on output gap and inflation in GCC countries in the short-term. In this context, monetary policy reacts to the inflation pressures coming from output gap shock (POG) by increasing interest rate (IR) which implies consequently the fall of oil prices (OP) in the short run. As the oil prices decrease (OP), the fiscal balance in GCC countries is expected to be negatively impacted in the medium run. The POG shock do not affect imports in the GCC countries.

GCC domestic output gap shock (OG) impacts positively fiscal balance, imports and domestic inflation in the short run. The increase of GCC output (OG), which indicates an excess of GCC oil supply, impacts negatively oil prices (OP) in the short run. Under such conditions, the output gap of GCC trading partners (POG) reacts positively and increase at the same time. Monetary policy is expected to decrease real interest rate (IR) by keeping policy rate constant after one year in order to react firstly to the fall of oil prices. Secondly, monetary policy is expected to increase interest rate in the long-term in order to react to the inflationary pressures coming from (POG).

The IRFs calculated from the second version of our estimated P-VAR model (alternative specification) illustrate a differentiated effect of oil price shocks, in terms of level and time lag, on fiscal balance and imports. In fact, fiscal balance and imports are more sensitive to oil price supply shock than oil price demand shock. Inflation reacts positively to the oil demand shock in the short run and negatively to the oil supply shock in the long run. Monetary policy reacts positively to the oil supply shock by increasing interest rate (IR) and remains neutral in the surge of oil demand shock.

We find strong evidence on asymmetric impacts of oil price shocks on macroeconomic activities in GCC countries and their partners. In fact, the reactions of output gaps of GCC countries (OG) and their partners (POG) to 'all' oil price shocks under the symmetric specification of P-VAR model are mitigated. However, using the asymmetric specification, we find evidence that OG and POG react positively to oil demand shock and negatively to oil supply shock. The results of this study show the importance of the source of oil price shock regarding their macroeconomic implications for GCC countries and their partners.



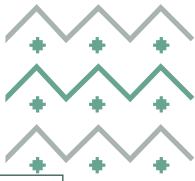


The paper therefore not only gives direct evidence of the differentiating impact of demand-driven and supply-driven oil shock on GCC countries and generally the oil-producing countries using P-VAR framework that is novel in the literature, but also suggests, as policy recommendation, that the use of fiscal policy tools to reduce the extent of negative oil price shocks on economic activity in GCC countries should be appropriate and adapted to the source of the oil price shock. According to our empirical results, the effect of supply-driven shock is more persistent on fiscal policy than demand-driven shock. This indicates that the tightening of oil market using a common production strategy (OPEC+) can boost in a sustainable way the fiscal policy in GCC countries. Also, the finding suggests that the reaction of monetary policy in GCC countries can be contractionary during the time of oil supply price shock and neutral or expansionary in the presence of oil demand price shock. In a future work, it will be interesting to assess do floating exchange regime matter in the asymmetry demand/supply of oil shock transmission mechanism by investigating the case of a group of non-opec exporting countries (including Russia, Canada, Norway, Mexico, Brazil).

### References

- Balke, N.S., S.P.A. Brown and M. Yucel (2002).** Oil Price Shocks and the U.S. Economy: Where Does the Asymmetry Originate? *The Energy Journal*, Vol. 23, No. 3, pp. 27-52.
- Bernanke, B.S., M. Gertler and M. Watson (1997).** Systematic Monetary Policy and the Effects of Oil Shocks, *Brookings Papers on Economic Activity*, Vol. 1997, No. 1, pp. 91-157.
- Cashin, P., K. Mohaddes, M. Raissi, and M. Raissi (2014).** The Differential Effects of Oil Demand and Supply Shocks on the Global Economy. *Energy Economics* 44, 113-134.
- Choi, S., Furceri, D., Prakash, L., Mishra S., Poplawski-Ribeiro, M. (2018).** Oil prices and inflation dynamics: Evidence from advanced and developing economies. *Journal of International Money and Finance*,
- De Gregorio, J. (2012).** Commodity Prices, Monetary Policy, and Inflation. *IMF Economic Review* 60, 600-633..
- Hamilton, J. D. (2009).** Causes and Consequences of the Oil Shock of 2007-08. *Brookings Papers on Economic Activity*, 2009, 215-261.
- Kilian, L. (2009).** Not all oil price shocks are alike: disentangling demand and supply shocks in the crude oil market. *American Economic Review*, Vol. 99, No. 3, pp.1053-1069.
- Villafuerte M. and Murphy P. L. (2009).** Fiscal Policy in Oil Producing Countries During the Recent Oil Price Cycle. *IMF Working Paper No. 10/28*, International Monetary Fund, Washington, DC.





**[DEMAND RESPONSE PROGRAM DESIGN: ENVIRONMENTAL AND ECONOMIC PERSPECTIVES]**

[Mohammed AL-Sadig AL-Haj, Qassim University, +966552075068, 381126393@qu.edu.sa]  
 [Azzam Hamad Alhumaidi, Qassim University, +966553420616, 381120974@qu.edu.sa]  
 [Abdulaziz Saleh Al Harbi, Qassim University, +966534452616, 371112188@qu.edu.sa]  
 [Mohammed Khalid ALthunayyan, Qassim University, +966555952512, 372113273@qu.edu.sa]

**Overview**

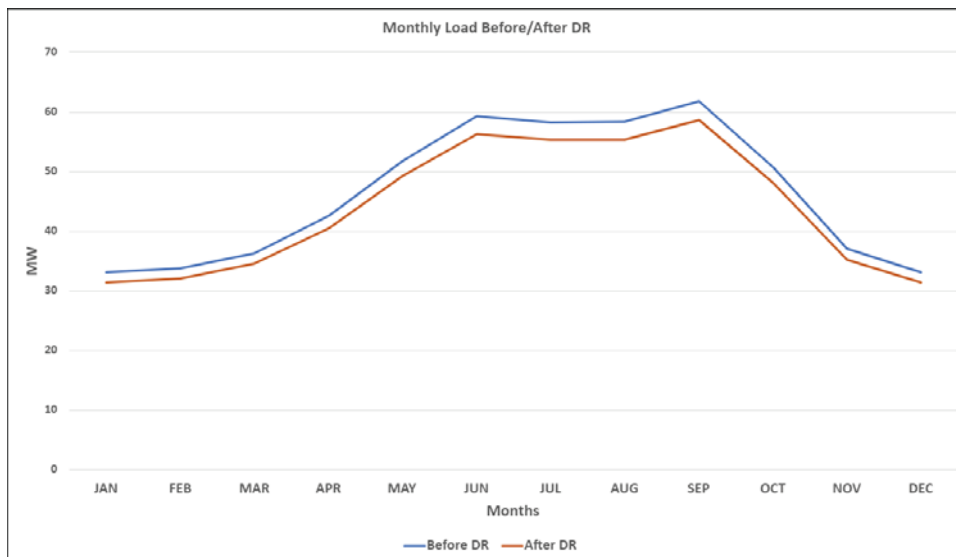
The increased use of energy leads to an increase in energy-related emissions. It is important to maintain Emissions from electricity generating units are under control by regulating the carbon footprint. Demand response (DR) refers to the modification of the consumption pattern on the part of the end consumer in a variety of ways and techniques. DR software has been developed to increase electrical system reliability by reducing peak hour loads. DR can provide economic efficiency and environmental benefits. This paper reviews the network in Saudi Arabia from generation to consumption and studies the economic and environmental effects of peak load before and after the application of a demand response program.

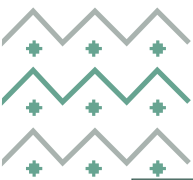
**Methods**

Designing a demand response program from an environmental and economic perspective, and using tools to reach the results.

Load data:

The loads will be used in Saudi Arabia for 2018, which was Approved by the annual report of the Water and Electricity Regulatory Authority[1]. The data was Extracted from the graph for download through the program (getdata Graph Digitizer) and The maximum value for each month was taken to work out the worst and highest load value ineach month, which will reduce the value of each month's peak loads by 5% Figure1 shows the peak consumption curve for each month of the year before and after the DR.





1- Environmental perspective:

The environmental perspective section contains data on environmental carbon emissions dioxide before and after application of the demand response, and contains miscellaneous environmental data showing the environmental impact of electrical energy consumption before and after the demand response program, as well as comparing emissions before and after.

2- Economic perspective:

The section contains cost-benefit analysis of generation, transmission and distribution of electricity based on the value of the load, by applying the laws of cost-benefit analysis. The construction and operational value of the stations is included in the calculation.

**Results**

The results shown in the table1 are a summary of what was provided economically and environmentally through the tools and equations that were used in each perspective.

parameter	amount
Energy Saving(kwh)	20868336
Peak Demand Saving (MW)	28.56
Metric tons Co2 Reduced	9036
Cost Saving (SAR)	4257140.544
Barrels of Oil Saving	28608

**Conclusions**

At the conclusion of the project, find that the demand response is economically and environmentally feasible, especially in the consumption network in which it grows like the Kingdom of Saudi Arabia. The demand response is environmentally feasible by reducing 28.56 MW and saving 9036 Metric tons of CO2. The demand response is economically successful by reducing the total cost by 4257140.544 SAR and saving 28608 barrels of oil. The difficulty and challenge were in collecting accurate data on the network and the load. Through the results of the study, it was found that the demand response is feasible, but it faces several challenges and incentives to implement them exceed the challenges. In the future work of the project, we will work on implementing all demand response programs on network in the Kingdom of Saudi Arabia and determining the most appropriate program of demand response programs to be implemented.

**References**

[1] ECRA Statistical Booklet 2018, Electricity & Cogeneration Regulatory Authority, Available: <https://ecra.gov.sa/>





## Submission Summary

### Conference Name

44th IAEE International Conference - 2023

### Paper ID

68

### Paper Title

Market integration in the global natural gas market - Empirical evidence on asymmetric price transmission

### Abstract

International trade in natural gas is divided into three main regional markets: Asia, Europe, and North America. The segmentation has been settled due to the small availability of natural gas transportation facilities among the three regions. However, the three natural gas markets are gradually becoming more integrated. Based on the law of one price, market integration implies that natural gas prices across those regions should differ by the transaction costs at most. However, the COVID-19 pandemic and the geo-political risks have brought uncertainties and disruptions to the supply and demand sides of the global gas market. This paper aims to estimate the effect of those shocks by conducting our empirical analysis over the sub-sample (2016-2019) and (2020-2021). This allows us to compare our results between a period with relatively stable market conditions and another period with adverse shocks. The paper also examines the causal relationships among the three gas markets using the time-varying Granger causality method. By doing so, we hypothesize that these causal relationships have a dynamic character and are affected by the uncertainties in the gas markets. Defining the lead-lag relationship may help market participants (i.e., traders and investors) determine their arbitrage and investment strategies.

The empirical analysis uses the daily gas price series for the one-month ahead futures for the North American, European, and Asian gas markets from 01/01/2016 to 31/12/2021. Our findings show an asymmetry in the market integration process before and after the pandemic. Our results suggest that the Granger causality between the gas price series exhibits a dynamic behavior. We found that the leading role of a market in price discovery depends on some factors, including demand growth due to economic growth or policy changes, supply disruptions due to infrastructure failures and disruptions, LNG imports, and geopolitical risks that may lead to a change in procurement structure. For example, the European market seems to lead the market since 2020, revealing how the geopolitical risks and adverse shocks caused in one region can affect the global gas market. These results provide relevant implications for regulators and portfolio risk managers in the gas market.

### Created on

9/3/2022, 1:24:10 PM

### Last Modified

9/3/2022, 1:29:35 PM

### Authors

Markos Farag ( University of Cologne ) < mfarag@smail.uni-koeln.de >

### Primary Subject Area

Natural Gas







## **CARBON-NEUTRAL LNG AND OIL: THE FUTURE OF HYDROCARBONS IN THE WORLD OF ENERGY TRANSITION?**

Zlata Sergeeva, King Abdullah Petroleum Studies and Research Center (KAPSARC),  
+966-56-704-1645, zlata.sergeeva@kapsarc.org  
Colin Ward, King Abdullah Petroleum Studies and Research Center (KAPSARC),  
+966-55-060-4335, colin.ward@kapsarc.org  
Rami Shabaneh, King Abdullah Petroleum Studies and Research Center (KAPSARC),  
+966-59-904-3969, rami.shabaneh@kapsarc.org  
Hamid Al Sadoon, King Abdullah Petroleum Studies and Research Center (KAPSARC),  
+966-50-595-9723, hamid.sadoon@kapsarc.org

### **Overview**

With the development of climate policies and various barriers to carbon-intensive products (for instance, the Carbon Border Adjustment Mechanism in the EU) in traditional energy importing countries, the carbon footprint of hydrocarbon products started to gain an increasingly crucial role, influencing the competitiveness of the key energy exporters. The rapid expansion of renewable energy sources and the creation of a new market for hydrogen is expected to have a negative impact on the demand for traditional energy sources. This research focuses on one of the methods of managing emissions in the energy sector – the evolving practice when traditional hydrocarbon producers are introducing carbon-neutral versions of conventional products: carbon-neutral oil and carbon-neutral natural gas (mainly LNG).

The carbon-neutral LNG market is new, but still much more developed than carbon-neutral oil or LPG and condensate. Despite being quite a new phenomenon (the first carbon-neutral LNG cargo was announced by Shell in June 2019), the carbon-neutral LNG market is rapidly developing. As of August 2022, 32 such cargoes were supplied worldwide, with Asia as a leading destination. However, despite the boom of carbon-neutral cargoes in 2021, this nascent market experienced a significant shrinkage in 2022, with only one cargo delivered and no new deliveries announced. In this research, we discuss the reasons for this drastic decrease, which go far beyond economics and geopolitics.

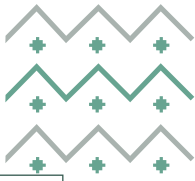
In this work, we show that the carbon-neutral hydrocarbons market faces some significant challenges. Among them is the lack of established standards on what to consider a carbon-neutral cargo, how to achieve its carbon neutrality, how to measure the emissions, to report and verify them. Despite multiple possible ways to manage emissions (e.g. introduction of such technologies as carbon capture, utilization and storage (CCUS), energy efficiency, or direct air capture (DACC), so far all carbon-neutral LNG and oil cargoes used carbon offsets as a method of achieving carbon neutrality. These challenges lead to a lack of transparency in the market and, as a result, a lack of credibility, which becomes a barrier to its expansion.

In this research, we achieve several targets:

- Describe current practices established in the carbon-neutral hydrocarbons market
- Show what standards are needed for the market to expand
- Produce estimates for the cost of a typical carbon-neutral LNG and oil cargo under different methods used to achieve carbon neutrality (offsetting with carbon credits VS introducing CCUS)
- Discuss the impact of the introduction of different approaches to managing emissions on the rebalancing of the traditional supply curves in the LNG and oil markets.

The rationale behind the research is to quantify the impact of carbon policy on hydrocarbon value chains in the hydrocarbon trade. Regulations to decarbonize the oil and gas sector are expected to impose additional costs for producers and consumers. The aim of the study is to understand the implications of carbon-neutral hydrocarbon cargoes and generate a new "energy map" under these conditions. Applying different approaches to mitigating emissions from fossil fuel products can lead to different outcomes for the economics of future carbon-managed hydrocarbon markets.





## Methods

In the first stage of research, we use the case study method to describe the current practice in the carbon-neutral trade of hydrocarbons. Simultaneously we scrutinize the role of existing carbon regulation and carbon offsetting. This helps us understand the parameters for potentially acceptable "carbon neutral" products, identify the technologies that can contribute to carbon neutrality, and the implications for supply chains.

In the second stage, we explore the consequences of carbon regulation for the LNG and oil market. We generate scenarios around the potential costs of carbon offsets and CCUS in different regions and use Nexant's World Gas Model to analyze possible restructuring of the LNG market due to the introduction of obligatory carbon regulation. A new LNG supply curve under different scenarios of carbon prices is produced.

## Results

We show that under current conditions rebalancing of the market is unlikely as "carbon neutrality" status for cargos is derived from the cancellation of carbon credits, issued from similar projects based in developing countries.

Future pricing is highly dependent on rules in the market. Because there is a lack of rules, producers seek the cheapest ways to offset emissions that don't affect the market. Currently, purchasing the offsets adds only up to 6% of the total cost of an LNG cargo.

Due to these reasons, such cargoes can be price competitive, especially under current market price conditions.

Only after changes in rules (e.g., if an obligation to offset emissions where production or consumption takes place is introduced) reconfiguration of price structure and supply chain of carbon neutral LNG or oil will occur.

## Conclusions

The research highlights multiple challenges existing in the carbon-neutral hydrocarbon markets – such as the lack of standards on what is "carbon neutrality", how to achieve it (what emissions and from what elements of the value chain need to be managed, who – the buyer or the seller is responsible for it. These challenges prevent the market from developing and decrease its attractiveness to potential investors and clients. However, in case recently developed standards (for instance, the joint methodology developed by Pavilion Energy, Qatar Energy, Chevron, and a methodology proposed by GIIGNL) manage to become universal, the market of carbon-neutral hydrocarbons could compete with conventional hydrocarbon products over the coming decades. Moreover, global emission mitigation targets of the countries and companies are still in place, and solutions to cut emissions will be a priority, especially after a weak performance in 2022. Once natural gas prices are normalized, importers will most likely focus again on their climate pledges, highlighting the benefits of carbon-neutral hydrocarbons again.

## References

Chevron Corporation, Qatar Energy, and Pavilion Energy. 2021. "The SGE Methodology. GHG Methodology for Delivered LNG Cargoes." First Edition, 2021. <https://www.chevron.com/-/media/chevron/sustainability/documents/SGE-methodology.pdf>.

GIIGNL. 2021. "GHG Neutral Framework." GIIGNL - International Group of Liquefied Natural Gas Importers. <https://giignl.org/framework/>.

GIIGNL. 2022. "GIIGNL Annual Report." GIIGNL - International Group of Liquefied Natural Gas Importers.

IGU. 2022. "2022 World LNG Report." International Gas Union (IGU).

Yip, Michael. 2021. "Carbon Neutral LNG Cargoes Database." Bloomberg New Energy Finance. <https://www.bnef.com/insights/26123>.





## ***NATURAL GAS CONSUMPTION IN AZERBAIJAN: IS THERE ROOM TO EXPORT MORE?***

Sarvar Gurbanov, School of Public and International Affairs (SPIA), ADA University, Baku, Azerbaijan, +994124373235  
[sgurbanov@ada.edu.az](mailto:sgurbanov@ada.edu.az)

Jeyhun I. Mikayilov, Energy and Macro & Microeconomics, King Abdullah Petroleum Studies and Research Center,  
Riyadh, Saudi Arabia, +966537324174, [Jeyhun.mikayilov@kapsarc.org](mailto:Jeyhun.mikayilov@kapsarc.org)

Shahin Maharramli, Economic Analysis, Tariff and Statistics Division, Azerbaijan Energy Regulatory Agency, Baku, Azerbaijan,  
+994707460302, [shahinmaharramli@gmail.com](mailto:shahinmaharramli@gmail.com)

### **Overview**

Azerbaijan is known as a resource-rich country. Furthermore, as IEA defines, the country has “one of the highest energy self-sufficiency ratios in the world.” As of 2021, the percentage share of oil and natural gas in the primary energy consumption of the country is 28 % and 69 %, respectively (BP, 2022). Put differently, 97 % of energy consumption is based on fossil fuels. The total proven natural gas reserves of Azerbaijan are 2,5 trillion cubic meters, and with the current rate of production, these reserves will be depleted in 96 years. Most recent data from IEA provides a breakdown of the sectors in the natural gas consumption; the residential sector makes up 65 % of the total, whereas the industry’s share remains at 19 % (IEA, 2022). Besides, the residential sector is traditionally the largest final energy consumer. Since no coal is used in the total energy consumption, the declining share of oil in the total energy mix paves the way for a bigger role for natural gas. It mainly stems from electricity generation. Over 90 % of the electricity in the country is generated in natural gas-fired power plants.

In the Azerbaijan case, even though Hasanov et al. (2017) examine energy consumption – growth nexus with panel data, including Azerbaijan, they do not provide disaggregated approaches, including natural gas. Furthermore, in terms of environmental impacts by employing ARDL, FMOLS, and DOLS models, Gurbanov (2021) finds that in Azerbaijan’s case increase in the share of natural gas in the total energy mix decreases CO2 emission per capita.

When it comes to the export potential of a country EU seems to emerge as a big buyer. European Commission classified the Southern Gas Corridor (SGC), which is planned to transport Azerbaijan gas to Europe, as a Project of Common Interest (PCI) (EC, 2019). A Memorandum of Understanding (MoU) entitled Strategic Partnership in the Field of Energy was signed between Azerbaijan and the EU commission. Put simply, Azerbaijan will keep increasing its natural gas exports. Deliveries of natural gas exports to the EU have been 8.1 billion cubic meters (bcm) in 2021 and are expected to reach 12 bcm in 2022. With above mentioned MoU, Azerbaijan committed to double the previously announced capacity of SGC and deliver at least 20 bcm of natural gas by 2027 (EC, 2022). Since natural gas is considered as greenest fossil fuel and the export potential of Azerbaijan is pretty much appreciated by big buyers like the EU, it is quite timely to estimate the income and price elasticities of natural gas consumption and investigate the potential of a country to export more.

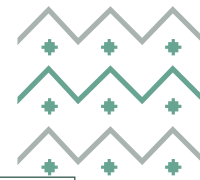
### **Methods**

The unit-root properties of variables are exercised via the Augmented Dickey-Fuller (Dickey and Fuller, 1981, ADF) unit root test. To assess the long-run relationship between the variables, we utilize the Engle and Granger (1987) and the Bounds (Pesaran et al. 2001; Pesaran and Shin 1999) cointegration tests. For estimating the relationships between the variables, we have utilized a set of estimation techniques for robust results. Namely, we have used the General to Specific (Gets) modeling approach (see Hendry and Doornik, 2014; Doornik and Hendry, 2018, among others), the Bounds Testing Approach to Autoregressive Distributed Lagged models (ARDLBT, Pesaran et al. 2001; Pesaran and Shin 1999), the Structural Time Series Modeling (STSM) approach (Harvey, 1989), the Fully Modified Ordinary Least Squares (FMOLS) method (Phillips and Hansen, 1990), the Dynamic Ordinary Least Squares (DOLS) method (Saikkonen, 1992; and Stock and Watson, 1993), and the Canonical Cointegration Regression (CCR) (Park, 1992) method.

### **Results**

The unit root test concluded all the variables to be integrated in the first order. This allows testing the variables for sharing a common long-run trend. The used cointegration tests both concluded the existence of a





cointegration relationship. After concluding the presence of the cointegration relationship between the variables of interest, in the next step, the long-run relationships are handled using the techniques mentioned in the Methodology section. The long-run estimation results are provided in Table 1. As the table shows, all used estimation techniques produced quite similar results. The signs of the coefficients of income and price variables are in line with the theoretical expectation, being positive for income and negative for price.

**Table 1: Long-run estimation results**

variable	Gets	ARDL	STSM	DOLS	FMOLS	CCR
gdppc	0.791***	0.816***	0.772***	0.730***	0.794***	0.779***
price	-0.110***	-0.118***	-0.100***	-0.161***	-0.093*	-0.088 <sup>a</sup>

Notes: gdppc=real per capita GDP, in logarithmic form; price=real price of natural gas, in logarithmic form; “\*\*\*” and “\*\*” stand for rejection of null hypothesis at 1% and 10% significance levels, respectively; a=it is significant at 14 % significance; in Gets, ARDL BT, DOLS approaches, maximum lag is set to 2. In Gets, the optimal lag is chosen based on the Autometrics machine learning algorithm and the number of diagnostic tests, while for the ARDL BT and DOLS, it is determined based on the Schwarz criterion. In STSM, the maximum lag is set to 2, and the optimal lag is chosen based on the Schwarz criterion and the number of diagnostic tests.

Source: Estimation results compiled by authors

## Conclusions

Regarding income and price elasticities of natural gas consumption, this study finds relevant elasticity coefficients and estimates the potential room for natural gas exports. All utilized estimation methods concluded the long-run income elasticity to be around 0.8, while the long-run price elasticity is around -0.1, except for the ARDL results. This means that, in the long run, all other circumstances being the same, a 1 % increase in income, on average, increases per capita natural gas consumption by 0.8 %. In a similar vein, a 1 % increase in price, on average, decreases per capita natural gas consumption by 0.1 %. As Mikayilov et al. (2018) put it, energy intensity in Azerbaijan’s economy is two times higher than the world average for one dollar of added value. Strategic Roadmap of the Azerbaijan economy targets high-income country status after 2025. This income increase will generate higher demand for natural gas, and at the same time, the country needs to increase its natural gas exports tremendously by 2027. Overlapping periods of export commitments and national income targets may pose a very striking trade-off between domestic consumption and consumption in the export markets. This study intends to find the magnitude of this trade-off.

## References

- bp Statistical Review of World Energy June 2022, 71<sup>st</sup> edition. <https://www.bp.com/en/global/corporate/energy-economics/statistical-review-of-world-energy.html> (18.08.2022).
- European Commission (EC), 2019. Annex: [https://ec.europa.eu/energy/sites/ener/files/c\\_2019\\_7772\\_1\\_annex.pdf](https://ec.europa.eu/energy/sites/ener/files/c_2019_7772_1_annex.pdf) (22.08.2022).
- European Commission (EC), 2022. EU and Azerbaijan enhance bilateral relations, including energy cooperation [https://ec.europa.eu/commission/presscorner/detail/en/IP\\_22\\_4550](https://ec.europa.eu/commission/presscorner/detail/en/IP_22_4550) (22.08.2022)
- Gurbanov, S. Role of Natural Gas Consumption in the Reduction of CO2 Emissions: Case of Azerbaijan. *Energies* 2021, 14, 7695. <https://doi.org/10.3390/en14227695>
- Hasanov, F., Bulut, C., Suleymanov, E., 2017. Review of energy-growth nexus: A panel analysis for ten Eurasian oil exporting countries, *Renewable and Sustainable Energy Reviews* 73: 369 – 386. <https://doi.org/10.1016/j.rser.2017.01.140>
- IEA, Azerbaijan: Key Energy Statistics 2019. <https://www.iea.org/countries/azerbaijan> (18.08.2022).
- Mikayilov, J.I., Galeotti, M., Hasanov, F.J., 2018. “The impact of economic growth on CO2 emissions in Azerbaijan”, *Journal of Cleaner Production* 197: 1558 – 1572. <https://doi.org/10.1016/j.jclepro.2018.06.269>





## ***IMPACTS OF THE COVID-19 PANDEMIC ON NATURAL GAS USE IN THE APEC REGION BASED ON THE JOINT ORGANISATIONS DATA INITIATIVE (JODI) DATA***

Nobuhiro Sawamura, Asia Pacific Energy Research Centre (APERC), (+81)3-5144-5844, nobuhiro.sawamura@aperc.or.jp

### **Overview**

At the beginning of 2020, the COVID-19 pandemic started to spread worldwide. In March 2020, the World Health Organization declared the worldwide outbreak of COVID-19 pandemic. Many people have been infected with and passed away by COVID-19 in many countries since then. Many nations have taken preventive measures such as lockdowns and declarations of emergency. Due to these severe restrictions, human and business activities have been limited and the world economy has experienced a global recession.

The governments' response to this health and economic crisis caused an unprecedented decline in global energy consumption, especially petroleum products. Crude oil production and petroleum products consumption decreased since the energy consumption in the transportation sector decreased. For instance, consumption of motor gasoline and kerosene-type jet fuels faced a serious and substantial reduction as human activities were restricted. Natural gas demand and supply was also affected by the COVID-19 pandemic, but to a lesser extent than oil. According to the International Energy Agency (IEA), global gas demand declined in 2020 (IEA 2022).

The Asia-Pacific Economic Cooperation (APEC) region has experienced the health, economic, and energy crisis of the COVID-19 pandemic as well. This region accounted for 38% of the world population, 54% of the world's GDP (PPP constant 2017 USD), and 58% of the world's total primary energy supply in 2019 (APEC 2022). Therefore, the COVID-19 pandemic has had significant effects on the energy in this region.

Then, this paper analyses how the COVID-19 pandemic has impacted the natural gas demand and supply in the APEC region based on data reported by the Joint Organisations Data Initiative (JODI). JODI consists of eight partner organisations<sup>1</sup>. APEC is one of the partner organisations. JODI collects the monthly oil and gas data (e.g., production, consumption, import, export, etc.) of member countries from its partner organisations (JODI 2020). APEC submits its non-OECD member economies data to IEF for JODI<sup>2</sup>.

### **Methods**

Statistical compilation and analysis of JODI and EGEDA gas data- This study provides an analysis of changes in gas production and consumption for the 21 APEC member economies' data from January 2018 to June 2022<sup>3</sup>. The analysis is based primarily on the JODI and EGEDA data but also uses additional sources for identifying the key drivers of consumption and production changes (e.g., heating degree days).

### **Results**

Gas production in the APEC region declined in 2020 compared with 2019. Gas production in the region reached 94.5 thousand Petajoules (PJ) in 2020, falling by 2.1% from 96.5 thousand PJ in 2019. However, it turned back to 98.7 thousand PJ in 2021 (Figure 1). From 2018 to the first half of 2022, the United States has been the top gas producer in the APEC region. In 2021 U.S. production comprised 38% of the total APEC gas production, followed by Russia (31%), Other Americas (9%), and China (8%). While the U.S. has the largest gas production in APEC, its total gas production reduced 0.4% to 36.3 thousand PJ in 2020, from 36.5 thousand PJ in 2019. The production decline was caused by decreased drilling activity related to low gas prices in 2020 (EIA 2021). Russia produced 27.7 thousand PJ in 2020, a decline of 5.7% from 29.4 thousand PJ in 2019. The COVID-19 pandemic spurred the decline in the U.S. natural gas price and a higher demand for LNG, causing more competition for Russian energy producers. Moreover, as gas demands in countries in Europe decreased due to lockdowns, the export volume of a Russian natural gas resource company declined, leading to its production cut in 2020 (Statista 2021). On the other hand, gas production in China increased by 10.1% to 8.1 thousand PJ in 2020 from 7.3 thousand PJ in 2019. To satisfy its domestic gas demand, China significantly increased its gas production in 2020. Due to vaccinations, regained human activities and economic recoveries, gas production in the APEC region increased to 98.7 PJ thousand (a 4.4% increase from the 2020 level) in 2021.

Although gas production decreased in 2020, the total APEC gas demand in 2020 reached 89.5 thousand PJ showing a 1.7% increase from 2019 levels of 88.0 thousand PJ. Based on this result, gas demand was lost due to the COVID-19 pandemic that restricted people's mobility, and various economic activities in early 2020, started to pick up again (Figure 2). As shown in Figure 2, Russia, China, Other Americas, and Other Northeast Asia (Japan and Korea, etc) showed increases in demand in 2020. The gas demand increase can be associated with the unexpected cold winter in 2020 in Japan and coal-to-gas switching in Korea (IEA 2021). Meanwhile, demands in the United States, Oceania, and Southeast Asia slightly decreased. Oceania showed a continuous decline in demand from 2019 to 2021 as electricity generated from natural gas in Australia continued to drop (Argus Media 2021). Same as gas production, gas consumption in the APEC region increased to 93 PJ thousand (a 3.9% increase from the 2020 level) in 2021.

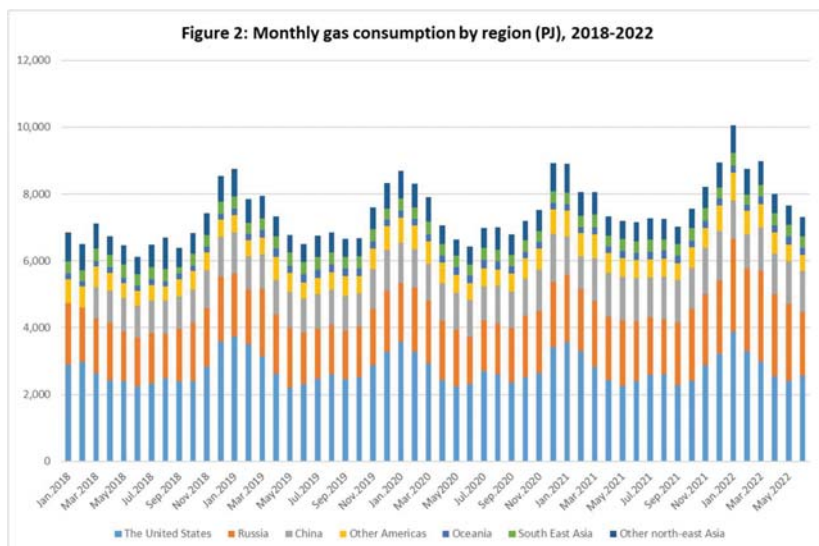
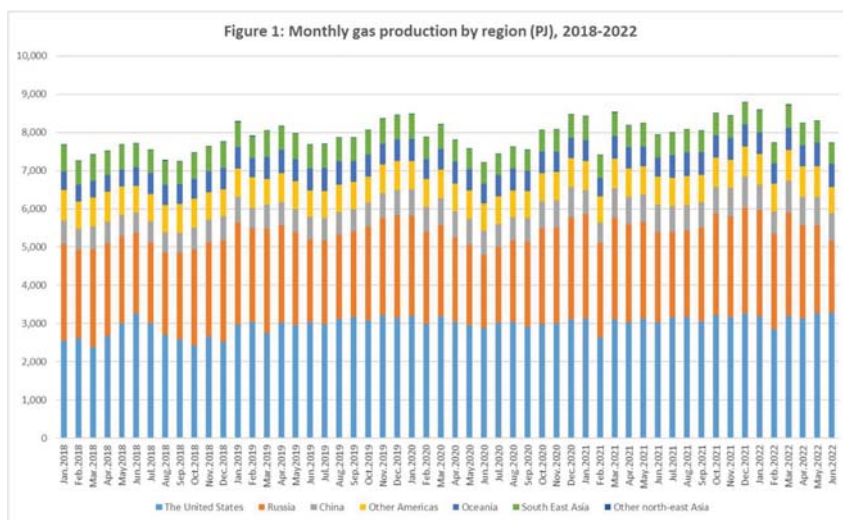
<sup>1</sup> Asia Pacific Economic Cooperation (APEC), Statistical Office of the European Communities (Eurostat), Gas Exporting Countries Forum (GECF), International Energy Agency (IEA), International Energy Forum (IEF), Latin American Energy Organization (OLADE), Organization of the Petroleum Exporting Countries (OPEC), United Nations Statistics Division (UNSD).

<sup>2</sup> In APEC, each member is named as an economy, not a country or nation.

<sup>3</sup> APEC has its energy database (the Expert Group on Energy Data and Analysis (EGEDA) website).







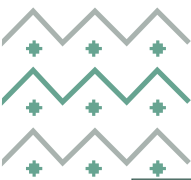
### Conclusions

Based on the analysis of JODI data, the APEC region has been evidently affected by the Covid-19 pandemic, showing its decrease in gas production and increase in gas consumption in 2020. Several factors such as weather and reduced infrastructure investments affected natural gas demand and supply in this region. This analysis will be conducted in the final paper.

### References

Argus Media 2021, "Australia 2020 electricity from natural gas falls 4.6pc", June 7, 2021, <https://www.argusmedia.com/en/news/2222123-australia-2020-electricity-from-natural-gas-falls-46pc>  
 APEC 2022, APEC Energy Statistics 2019, July 2022, APEC, [https://www.egeda.ewg.apec.org/egeda/general/info/pdf/APEC\\_Energy\\_Statistics\\_2019.pdf](https://www.egeda.ewg.apec.org/egeda/general/info/pdf/APEC_Energy_Statistics_2019.pdf)  
 EIA 2021, "Annual U.S. natural gas production decreased by 1% in 2020", TODAY IN ENERGY, March 2, 2021, U.S. Energy Information Administration, <https://www.eia.gov/todayinenergy/detail.php?id=46956>  
 IEA 2021, "Global Gas Review 2020", <https://www.iea.org/reports/gas-market-report-q2-2021/global-gas-review-2020>  
 IEA 2022, "Gas 2020: Analysing the impact of the Covid-19 pandemic on global natural gas markets", June 2020, <https://www.iea.org/reports/gas-2020>  
 JODI 2020, "Historical Background: JODI and Oil Data", <https://www.jodidata.org/about-jodi/history.aspx>  
 Statista 2021, "Natural gas production in Russia from 2000 to 2021", <https://www.statista.com/statistics/265335/natural-gas-production-in-russia-since-1998/>





## ***ESTABLISHING DIALOGUE IN THE INTERNATIONAL LNG MARKET: A DECADE OF LNG PRODUCER-CONSUMER CONFERENCES***

Kazutomo Irie, President, Asia Pacific Energy Research Centre (APERC), +81-3-5144-8551, kazutomo.irie@aperc.or.jp

### **Overview**

Since 2012, Japan's Ministry of Economy, Trade and Industry (METI) and the Asia Pacific Energy Research Centre (APERC) have organized the LNG Producer-Consumer Conference each year, inviting representatives of governments and business from both LNG producing and consumer countries as well as experts in the energy field. Over the last 10 years, the Conference has addressed many LNG issues, with the focus shifting from flexibility of contract conditions to market development, and then to the role of LNG in decarbonizing energy supplies. Now the Conference is well established as an important forum for dialogue between participants in the international LNG market. In its second decade starting in 2022, the Conference will be a key venue for discussing how best to deal with the turbulence in the international LNG market triggered by the Russia-Ukraine War.

This paper reviews and analyses the establishment and evolution of the LNG Producer-Consumer Conference. The evolution of the LNG Conference is compared to the history of other multilateral oil organizations, highlighting key economic and regulatory differences between the international oil market and the international LNG market.

### **Methods**

Historical analysis of the evolution of the LNG Producer-Consumer Conference, based primarily on Conference documents and records. This evolution is compared with the well documented evolution of international producer and consumer organizations focused on the oil market.

### **Results**

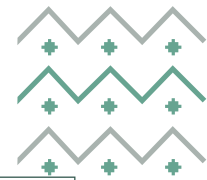
In September 2012, Japan's METI held the first LNG Producer-Consumer Conference in Tokyo. APERC which was established by METI as a regional research institute was asked to be a co-host. At that time, METI faced high LNG import prices, the so-called "Asian Premium", due to traditional, rigid contract provisions such as oil-linked price formulae or destination clauses. After the Great East Japan Earthquake in March 2011 and resulting shutdown of nuclear power stations, Japan had to increase LNG imports as a substitute fuel for electricity generation. High LNG prices due to rigid contract terms became a large burden on the Japanese economy. The spread between Japanese gas price and those of Europe and the US reached at about \$8 and \$13/MMBtu respectively. To solve this problem, METI decided to host the LNG Producer-Consumer Conference as a forum for both LNG exporters and importers to openly discuss international LNG market issues, rather than hold bilateral negotiations with each LNG exporter to Japan. Japan is a pioneer in importing LNG in Asia and it accepted traditional rigid contract provisions for many years. Now as the world largest LNG importing country, Japan assumed the responsibility to address the Asian Premium, not only for Japan herself, but also for other LNG importing countries in Asia. To set up a multilateral forum between LNG exporters and importers, Japan chose Qatar, the world largest LNG exporting country then, as a "partner" of the Conference. After the opening remarks by Mr. Yukio Edano, Japan's Minister of Economy, Trade and Industry, Qatari Minister of Energy and Industry, Dr. Muhammed Bin Saleh Al-Sada, was invited to deliver a keynote lecture. In addition, ministers in charge of energy in Australia, Korea, and Canada gave special lectures and 26 panellists joined in presentations and discussions during 4 sessions. More than 600 participated in the first Conference.

METI continued the Conference as an annual event in 2013 and 2014 with a similar format to the first Conference. The number of participants exceeded 1000 from 2013. The fourth Conference held in September 2015 marked a turning point: with growing supply from Australia and the US, the international LNG market became a buyer's market and traditional rigid, contract provisions were loosened, even though they remained in place. The price spread between Japan and Europe/the US narrowed about \$2 and \$5 respectively in early 2016. On the other hand, lower LNG prices in a buyer's market may discourage investments by sellers and producers which could reduce future LNG supplies. Conference discussions moved more to supply security of LNG in longer term and new demand for LNG such as transportation fuels became topics in the Conference for the first time. The development of LNG market for the benefit of both producers and consumers formed the keynote of the LNG Producer-Consumer Conference in the 2010s. The prestige of the Conference was further heightened after 2016. The number of attending energy ministers largely increased to reach at thirteen in 2019. Geographically, ministers outside Asia and Pacific region (Oceania and the



Natural Gas





Americas) joined the Conference: Nigeria in 2016 and Mozambique in 2017 and 2018. The LNG Producer-Consumer Conference was well established as a high-level international forum.

The second turning point for LNG Producer-Consumer Conference came in 2020. The COVID-19 pandemic required that the ninth Conference be held online just like other international meetings. The online format inevitably shortened the duration of the Conference from full one day in the first through eighth Conference to only three hours. In person ministerial participation was limited to Japan and Qatar only. Instead, the Conference Secretariat set up the website where many ministers, business leaders and experts contributed video messages. More importantly, the 2020 Conference emphasized the role of LNG in decarbonizing energy transition. In previous Conferences, LNG was referred clean energy in terms of no air pollution and relatively low carbon emission among fossil fuels. However, as many countries including Japan pledged carbon neutrality by mid the 21<sup>st</sup> century, carbon emission by LNG started to be questioned. In 2020, decarbonization through LNG value chain was discussed as well as price mechanisms favourable and sustainable for both producers and consumers. The ninth Conference was held on October 12, together with other 5 international meetings related to decarbonization, making the week from October 7 to 14 as Tokyo "Beyond-Zero" Week to advocate "Environmental Innovation for Beyond-Zero" with not only enabling carbon neutral efforts but also retroactively reducing CO2 emissions in the stock base.

The tenth Conference was also held online in October 2021 due to prolonged pandemic. In the Conference, LNG was considered to be the key resource for energy transition. Increasing the role of LNG as "transition energy" and ways of producing and using "clean LNG" were discussed. For this online Conference, the website was maintained to receive many video messages from around the world. Together with 7 other international meetings related to decarbonization, the Conference was again a part of Tokyo "Beyond-Zero" Week.

In reviewing the history of the LNG Producer-Consumer Conference, several questions arise. First, why was this Conference initiated not by Japanese importers but by the Japanese Government? In other words, why was the Conference held primarily on a government-to-government basis? An answer would be that LNG exports require large scale investments that inevitably invite policy intervention by governments of exporting countries. In many cases, LNG producers are nationally owned companies. Even if LNG producers are private companies, they need permission to construct LNG facilities and export LNG from the governments of exporting countries. Therefore, LNG importers have difficulties to solve serious commercial issues with exporters without involving governments of importing countries. Second, if the involvement of governments of importing countries was requested, why the Japanese Government chose to hold this multilateral conference rather than to have a bilateral meeting? The answer would be that the Japanese Government tried to increase its bargaining power against LNG exporting countries by inviting other LNG importing countries. Third, on the other hand, why did the Qatari Government accept the invitation to this multilateral conference rather than to have a bilateral negotiation? Maybe the Qatari Government foresaw the increase in global LNG exports, including unconventional LNG exports from the US, in future and hoped to use the Conference to further develop the international LNG market in order to secure Qatar's own market.

These questions lead comparison between producer-consumer dialogue in the oil market and the LNG market. The international oil market was well established when oil exporters and importers confronted each other in the 1970s. Oil exporters gathered at the Organization of the Petroleum Exporting Countries (OPEC) cartelized exports. Oil importers formed the International Energy Agency (IEA) and coped with cartelization by joint stockpiling and other measures. Their confrontation continued in the 1970s and the 1980s, but both agreed to have a producer-consumer dialogue at ministerial level as International Energy Forum (IEF) in 1991. The IEF set up a permanent Secretariat in 2003 in Riyadh, Saudi Arabia. Compared to the IEF, the LNG Producer-Consumer Conference is less institutionalized and smaller in terms of participating countries. The reason is the nature of the international LNG market. LNG markets had been divided into three regions in Europe, the Americas, and Asia, since LNG had been difficult to transport in long distance. LNG was a relatively new energy resource compared to oil or pipeline gas. The international LNG market was still on the way to establishment in the early 2010s. However, the international LNG market has grown up enough to establish a producer-consumer dialogue, even though in a less institutional format and smaller scale.

### Conclusions

On September 27, 2022, the eleventh LNG Producer-Consumer Conference will be held online again. The meeting format will be not so different from the previous two online Conferences in 2020 and 2021. However, the Russia-Ukraine War which started in February 2022 has dramatically altered the international LNG market. As a part of economic sanctions against Russia, developed countries in the West are trying to reduce both LNG and pipeline imports from Russia which in 2021 accounted for 25% of global natural gas exports. How to secure LNG supplies while reducing dependence on Russian gas will be a key issue at the Conference. In 2021, China and Australia replaced Japan and Qatar as the world largest LNG importer and exporter. However, the LNG Producer-Consumer Conference is already well established as a premier forum for dialogue between international LNG market participants, regardless of Japan's and Qatar's market position. In its second decade, the LNG Producer-Consumer Conference will be a key venue for discussions on how best to deal with the turbulent and constantly changing international LNG market.







## ***AN EXPLORATORY STUDY OF HYDROGEN PRODUCTION BY NATURAL GAS WITHOUT CARBON SEQUESTRATION***

[Jameel Jamhar, Department of Chemical Engineering, National Institute of Technology Agartala, Agartala, Tripura 7 Tripura 799046, India, +919746849548, jameeljamhar@gmail.com]

[Sukriti Sharma, Department of Chemical Engineering, Indian Institute of Technology Ropar, Rupnagar, Punjab 14000 +916386261029, Sukriti.20chz0001@iitrpr.ac.in]

[A.H. Sahir, Department of Chemical Engineering, Indian Institute of Technology Ropar, Rupnagar, Punjab 140001, In +919772271581, asad.sahir@iitrpr.ac.in]

### **Overview**

At present, nearly 90% of Hydrogen consumed in India comes from fossil fuels categorized as grey Hydrogen. B 80% of Hydrogen produced will be green as per the estimates of The Energy and Resources Institute i.e. Hydroge renewable resources as feedstocks. The pace of Hydrogen technologies is accelerating with production pathv different renewable energy sources like water wind solar and conventional technologies like steam methane reform crucial to assess the potential role of hydrogen from an economic perspective considering its vast future poter developed an exploratory study to evaluate the techno-economic feasibility of a hydrogen plant capable of producin Hydrogen.

### **Methods**

The cost analysis is performed using the H2A (Hydrogen Analysis) Hydrogen production model developed by the U of Energy (DOE) Hydrogen program. The H2A tool requires financial and economic input parameters to calculate cost of Hydrogen produced. The levelized hydrogen cost was estimated using a standard discounted cash flow meth specified after tax internal rate of return (IRR) of 11% from the production technology.

### **Results**

The results for the Indian scenario show that for an 11% internal rate of return (IRR), the production plant de Methane Reforming (SMR) with two production pathways can produce Hydrogen at a cost of \$2.05/kg v sequestration and \$3.33/kg with carbon sequestration. A sensitivity analysis of Hydrogen cost to various paramete presented. From our independent analysis we could almost match the cost that was reported by the NITI Ayog rep presented a cost of \$2.1 for the production of hydrogen by natural gas without carbon sequestration. While with o got the levelized cost of hydrogen produced to be \$2.05. With the carbon sequestration included the RMI analysis : of \$3.40 where our cost was \$3.30 per kg of hydrogen produced. A risk analysis study was done to perform sensitiv different variables within the cost of hydrogen. The results of the analysis are shown graphically in a tornado chart.

### **Conclusions**

The results of this poster presentation estimates the levelized cost of hydrogen price at 2022 using various tec assumptions. The main cost key component of the production is the cost of feedstock which is natural gas. W production pathways which is production of hydrogen by natural gas without carbon sequestration and with carbon s The analysis was done for a plant that would produce 483,014kg of hydrogen per day with an operation capacity sensitivity calculations exhibited that the feedstock consumption had the biggest influence on the price of the le hydrogen produced, followed by the after tax internal rate of return. The capital investment, fixed operating cost capacity factor were varied to understand the influence all these factors have on the price of hydrogen.

The gray hydrogen is currently a market of almost \$150 billion. But gray hydrogen mainly being a major polluter, th turned to produce blue hydrogen which is with carbon capture and storage. There is also an indication that the cli blue hydrogen production would be similar to green hydrogen if emissions are minimized. While there is a lot of l green hydrogen, all the cost factors should be taken into consideration such as the price of producing green hydroger

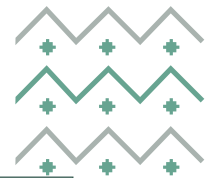
### **References**

1. M. Penev, G. Saur, C. Hunter, J. Zuboy. "H2A Hydrogen Production Model Version 3.2018 User Guide-Draft 11/
2. Eric Lewis, Matthew Jamieson, Travis Shultz, "Comparison of Commercial State of the Art, Fossil-Ba Production Technologies", DOE/NETL-2022/3241
3. NITI Ayog- "Harnessing Green Hydrogen " , Report / June 2022
4. International Energy Agency -"India Energy Outlook 2021"
5. Will Hall, Thomas Spencer, G Renjith, Shruti Dayal -"The Potential Role of Hydrogen in India : A pathway for carbon hydrogen across the economy", The Energy and Resources Institute (TERI).
6. Edwin A. Harvego, James E. O'Brien, Michael G. McKellar -" System Evaluation and Life cycle cost analysis of scale high temperature electrolysis hydrogen production plant", IMECE2012-89649
7. K. M. Guthrie, " Data and Techniques for preliminary Capital Cost Estimating", Chemical Engineering, March 1/
8. Gavin Towler, Ray Sinnott " Chemical Engineering Design : Principles, Practice and Economics of Plant and Pr Third Edition



Natural Gas





## Emissions & Economic Implications of Low-Cost Blue Hydrogen Supply from the Gulf States

Manal Shehabi, St. Antony's College, Oxford University; SHEER Research & Advisory, +447534209595, [manal.shehabi@sant.ox.ac.uk](mailto:manal.shehabi@sant.ox.ac.uk)  
 Frank Jotzo, Crawford School of Public Policy, Australian National University, +61261254367; [frank.jotzo@anu.edu.au](mailto:frank.jotzo@anu.edu.au)

### Overview

Hydrogen has been identified as a key element of a future net-zero global energy system and a potential solution for energy access and security. Hydrogen and its derivatives produced from low-emissions technology would be used at large scale, including as a clean energy feedstock in industry including the hard-to-abate sectors, a clean fuel in transport, and in the power sector. The overall future role of hydrogen in the global energy system is uncertain but could be large. The share of clean hydrogen in total global energy demand by 2050 has been projected between 3% if countries meet their announced decarbonization pledges (Announced Pledge Scenario by IEA (2021a)) to 13-16% in a net-zero world (Net-Zero Case by the IEA (2021a; 2021b)), up to 12% in a 1.5 °C scenario (IRENA, 2021), and 22% (BloombergNEF, 2021; Hydrogen Council, 2021).

The production method for low-carbon hydrogen has major implications for greenhouse gas emissions, costs, and location of energy production. Green hydrogen produced from electrolyzing water using renewable energy is the obvious long-term solution as it is free of greenhouse gas emissions, but blue hydrogen produced from fossil fuels especially natural gas with carbon capture, and storage (CCS) technology is a contender especially in the near term and in locations with very low cost hydrocarbon supply.<sup>1</sup> Blue hydrogen from natural gas is generally cheaper to produce than green hydrogen, at current feedstock and technology prices. Green hydrogen is expected to become cheaper with falling costs for renewable energy installations and electrolyzers, and with regard to policies that penalize emissions from fossil fuels. But the present-day cost advantages of blue hydrogen are large, especially where the shadow cost of gas extraction is low and the resource is extremely abundant, such as in Gulf hydrocarbon producing countries. Unlike in other parts of the world, blue hydrogen production in Gulf countries continues to be competitive even after the rise of gas prices following Russia's invasion of Ukraine and the subsequent energy security crisis in Europe because of abundant domestic supply.

Further, in gas producing countries and regions, gas-based hydrogen fits readily with existing fossil fuel infrastructure and the interests of existing large industries. More specifically within gas-producing countries, blue hydrogen also fits readily with Gulf countries for two factors. The first is Gulf States' limited renewable energy infrastructure, which is currently insufficient for domestic power and green hydrogen plans (Shehabi, 2021). The other factor is fiscal priorities. Gulf states face fiscal constraints post-pandemic owing to pandemic-triggered declines in hydrocarbon export prices and demand along with large costs of COVID-recovery packages. Said constraints exacerbate future fiscal sustainability concerns in light of reduced future global hydrocarbon demand and substantial government budget requirements to fund welfare distributive measures and limited contributions of non-hydrocarbon diversified sources to government budgets (Shehabi, 2022). Thus, these states' response to global decarbonization efforts has been to diversify existing hydrocarbon sectors to energy sectors, which have interests in expanding into sources with the highest profit margins, thereby favoring blue over green hydrogen.

Blue hydrogen inevitably has some extent of remaining greenhouse gas emissions from imperfect CCS processes and the natural gas supply chain (Longden et al 2022), which will need to be compensated for in a net-zero global energy system. Indeed, some likely hydrogen importers such as the European Union at this stage are planning to rely predominantly or exclusively on green hydrogen. However, if blue hydrogen remains cheaper than green hydrogen, it could speed up the transition on the basis of its cost advantage and low opportunity costs of importing the natural gas.

Hydrocarbon exporters in the Gulf region are preparing to become large suppliers of hydrogen and have positioned themselves as future hydrogen leaders. They have announced large hydrogen production plans (in Saudi Arabia, Oman, and the UAE), and adopted hydrogen strategies or plans to that end (Saudi Arabia, Oman, and Kuwait) along with net-zero emissions targets (the UAE by 2050, and Saudi Arabia and Bahrain by 2060) (Shehabi, 2021). However, and despite ambitious green hydrogen plans, gas-based blue hydrogen production is likely to expand significantly faster than green hydrogen in Gulf countries owing to their abundant low-cost gas supplies, huge established gas supply chains, and their estimated low cost of blue hydrogen production.<sup>2</sup>

The pertinent questions thus are: what are the best ways to make blue hydrogen from low-cost gas supplies be part of an effective solution for reducing emissions globally; how will remaining emissions from the blue hydrogen production chain be dealt with in relation to net-zero targets; and what are implications for the cost of future energy systems and producing countries' economies. These questions are critical for energy transition pathways towards net-

<sup>1</sup> Technically, blue hydrogen is a term used to describe hydrogen produced from all fossil fuels with CCS technology. This paper focuses on blue hydrogen produced from natural gas, as it is the fuel mostly likely to be used at large scale in blue hydrogen production, especially in the Gulf region.

<sup>2</sup> To demonstrate, Hasan & Shabaneh (2022) estimate that Saudi Arabia can produce at \$1.34/kilogram of hydrogen (kg H<sub>2</sub>) with costs expected to reach \$1.13/kg by 2030) owing to scale improvements.



zero targets, and especially relevant for examining the ability of the Gulf region to be an effective part of the global decarbonization efforts.

## Methods

The study provides and applies a quantitative model that examines future emissions implications of blue hydrogen production in hydrocarbon-producing Gulf economies under different scenarios of technology, costs, demand, and decarbonization policy. The model uses data from sources available in the public domain and academic research, including work done by Shehabi (2021), Shehabi & Dally (2021), Longden et al. (2022), Hasan & Shabaneh (2022), as well as the IEA (2022) and the Hydrogen Council (2022). Further, the study evaluates economic implications by evaluating the shadow cost of remaining emissions relative to production costs, the risk of stranded assets, and the broader context of economic diversification needs in Gulf states.

## Results

The tentative results of the study are the following.

- The Gulf hydrocarbon countries have a large cost advantage in gas-based hydrogen, both in comparison to other regions and countries, and for the time being relative to green hydrogen. Gulf states' strategies, near-term relative costs and expected emergence of international demand for hydrogen and hydrogen based fuels suggest that large blue hydrogen system are likely to be established in the Gulf states.
- The total emissions of blue hydrogen produced by the Gulf states would be smaller than emissions embedded in gas under high rates of CCS and other conditions; however, remaining emissions from the production chain create tensions with net-zero outcomes, and likely falling costs of green hydrogen are likely to make blue hydrogen less competitive over time. The trajectories vary greatly under different scenarios for energy demand, emissions policies, and technology costs.
- There is a risk of blue hydrogen stranded assets in the Gulf, even when taking into account very low gas extraction costs, stemming largely from importers' decarbonisation policies. In the broader context of economic opportunities and needs, blue hydrogen is an obvious opportunity for Gulf states, but is no substitute for economic, energy, and technological diversification and increasing investments in renewable energy production chains.

## Conclusions

The Gulf hydrocarbon economies are poised to establish blue hydrogen supply chain, based on present-day cost competitiveness, ample gas availability allowing them to ramp up hydrogen production quickly and at scale, and institutional factors that favour expansion of existing resource industries. If the production chain is relatively low in methane and carbon dioxide emissions, their hydrogen projects will contribute to global emissions reductions in the near to medium term. Medium to longer term, however, blue hydrogen faces constraints from net-zero emissions imperatives and likely falling costs of green hydrogen production, creating the risk of some blue hydrogen assets built or used in coming years to be stranded in coming decades. This outcome suggests that Gulf hydrocarbon economies need to carefully consider longer term economic implications of blue hydrogen production in light of opportunities for green hydrogen, and in the context of broader opportunities and need for technological and economic diversification.

## References

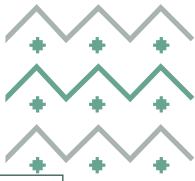
- BloombergNEF (2021). *New Energy Outlook 2021*. Bloomberg New Energy Finance, London.
- Hasan, S, & Shabaneh, R. (2022). The Economics and Resource Potential of Hydrogen Production in Saudi Arabia. *KAPSARC Working Paper*. DOI:10.30573/KS--2021-DP24
- Hydrogen Council (2021). *Hydrogen Insights: A perspective on hydrogen investment, market development and cost competitiveness*. Hydrogen Council.
- IEA (2021a). *Net Zero by 2050, A Roadmap for the Global Energy Sector*. IEA, Paris, [https://iea.blob.core.windows.net/assets/deebef5d-0c34-4539-9d0c-10b13d840027/NetZeroBy2050ARoadmapfortheGlobalEnergySector\\_CORR.pdf](https://iea.blob.core.windows.net/assets/deebef5d-0c34-4539-9d0c-10b13d840027/NetZeroBy2050ARoadmapfortheGlobalEnergySector_CORR.pdf).
- IEA (2021b). *Global Hydrogen Review 2021*. , IEA, Paris, [www.iea.org/reports/global-hydrogen-review-2021](http://www.iea.org/reports/global-hydrogen-review-2021).
- IRENA (2021). *World Energy Transitions Outlook*. IRENA, Abu Dhabi.
- Longden, T., Beck, F. J., Jotzo, F., Andrews, R., & Prasad, M. (2022). 'Clean' hydrogen? – Comparing the emissions and costs of fossil fuel versus renewable electricity based hydrogen. *Applied Energy*, 306, 118145. DOI: 10.1016/j.apenergy.2021.118145
- Shehabi, M. (2021). The Case of Hydrogen in the Gulf States: Opportunities and Challenges. Paper presented at the OIES-KFAS Workshop 2021. Oxford, UK.
- Shehabi, M. & Dally, B. (2021). Opportunity & Viability of Green Hydrogen in Kuwait: A Preliminary Assessment. *International Association of Energy Economics Working Papers*, Working Paper 21-536.
- Shehabi, M. (2022). Modeling long-term impacts of the COVID-19 pandemic and oil price declines on Gulf oil economies. *Economic Modelling*, 112, 105849. <https://doi.org/10.1016/j.econmod.2022.105849>.

Shehabi & Jotzo 2



Natural Gas





## Gas Games with Electricity

Kelly Neill, University of Sydney, [kelly.neill@sydney.edu.au](mailto:kelly.neill@sydney.edu.au)

### Overview

Should policy makers be concerned when firms with market power in natural gas simultaneously generate electricity? One concern is that a higher price of natural gas (hereafter referred to as simply "gas"), raises the cost of gas-fired electricity generation, and is passed through to the electricity price. It is therefore possible that a large gas firm could increase its electricity profit by raising the gas price, if it generates electricity from non-gas-fired inframarginal plants. This is an example of profiting by raising rivals' costs, as first identified in a general form by Salop and Scheffman (1983). A second concern arises when gas firms generate gas-fired electricity. When electricity and gas markets differ in terms of their timing and variability, this can create the type of adverse selection identified in theoretical work by Vives (2011). I present the first empirical evidence of this problem.

Before drawing policy conclusions, it is important to understand the behavior of firms operating in both gas and electricity markets. To do this, I follow pioneering theoretical work by Vives (2011), and use a Bayesian supply function equilibrium (SFE) model with asymmetric information. I adapt this model to study the eastern Australian energy markets. To my knowledge, this application is the first empirical estimation of this type of model. I find evidence that both adverse selection and the incentive to raise rivals' costs are a concern, though adverse selection is more important in Australia's case.

In eastern Australia, retail markets for both gas and electricity have been deregulated and opened to competition. To support this deregulation, Australia, like many countries, has auction mechanisms for trading spot electricity. Uniquely, it also uses daily uniform-price auctions facilitate trade in wholesale gas. The fact that a market operator runs auctions for both electricity and gas gives a unique opportunity to study the links between the two markets. Each day, the market operator runs four separate gas auctions, in physical hubs based around the large cities. Bids take the form of supply schedules. Since 2018, these auctions have covered 55 to 60 percent of domestic gas use in eastern Australia. I focus on the largest gas hub, which covers all gas flows in the state of Victoria, including Melbourne. Three large companies dominate the gas auctions, supplying 75 to 50 percent of gas injections in Victoria. These same three companies also own electricity generation plants, fueled by gas, coal and renewable energy, amounting to almost 50 percent of total dispatchable capacity. The firms are vertically integrated, in the sense that they have retail arms for both gas and electricity

### Methods

I contribute to the literature by estimating a theoretical model first proposed by Vives (2011), and later extended by Bergemann, Heumann, and Morris (2021). This theoretical work derives a unique SFE in which large firms compete by choosing supply functions. They do not know their costs before doing so, but receive private noisy signals about their own costs. Costs are correlated across bidders. I adapt this model to describe bidding behavior in Australia's gas auctions, paying particular attention to how electricity sales affect incentives. It is apt because firms do not know the electricity market outcomes before submitting their gas bids, and these outcomes are positively correlated across firms. Further, the three large firms are likely to have asymmetric information since they are better-informed about their own generation than that of their rivals.

Before estimating the model, I must construct key variables outside it. I require daily forecasts of firms' gas-fired generation to assess the importance of adverse selection; and each firms' net spot electricity sales to quantify incentives to raise rival's electricity costs. With this information, and detailed bidding data, I estimate the remaining cost and information parameters in the structural model, using necessary conditions for optimal bidding. Then, I use counterfactual analysis to disentangle the two channels through which electricity sales affect gas bidding, and to measure their impact.







## Results and conclusions

### *Adverse Selection*

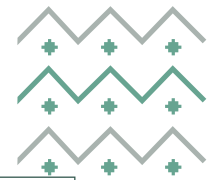
I find that adverse selection is a problem in the Australian gas auctions. When firms submit bids to supply the gas hub, they do not yet know how much gas they will need for electricity. This is because the gas market is cleared ahead of time, with the bids and outcomes covering a full 24 hours, while the electricity auction is settled close to real time. However, the more gas a firm uses for gas-fired generation, the higher its marginal cost of supplying the gas hub. When designing its gas bids, the firm can use public and private information to forecast its daily gas-fired generation, but it can also use information contained in the gas price itself. A high realized gas price indicates that the firm's rivals anticipate using a lot of gas for electricity that day. In this case, the firm itself is also likely to have high gas-fired generation, since this is positively correlated across the firms. That is, a high gas price informs the firm that it will likely have a high marginal cost of supplying the gas hub. In response, at higher prices, the firm offers smaller quantities to the hub than it otherwise would.

Thus, firms bid by submitting steeper supply schedules than otherwise, and, in equilibrium, trade smaller volumes in the daily gas auctions. This is counter to the intended purpose of the markets – which is to promote spot trade of wholesale gas, so that gas is delivered to the hub at lowest cost. I find evidence that gains from trade are left on the table every day, lowering the trade surplus by an estimated 10 per cent on average. To reduce adverse selection, policy-makers should take steps to improve the information that firms have about electricity outcomes before they submit their gas supply bids. One possibility is to make public electricity forecasts more accurate, although this may not be feasible. Another possibility is to increase the frequency with which the gas auctions are cleared, so that firms can gather more information about their electricity generation before committing to gas supply bids. A naive policy response of requiring firms to divest gas-fired electricity generation would do little to alleviate adverse selection. The information problem would remain as long as the firms supply gas to any power plant, even if they do not own the plant themselves.

### *Raising Rivals Costs*

The incentive to raise rivals' electricity costs is also a potential concern. I show that the spot gas price is passed through to the spot electricity price, whenever a gas-fired generator is setting the electricity price. While a higher gas price would increase a firm's own gas-fired generation costs, the resulting higher electricity price means that its other infra-marginal generation types (coal and renewables) would earn additional revenue without the cost increase. A firm's incentive to raise rivals' costs is larger the more electricity it sells in the spot market, and the more often a gas-fired generator sets the electricity price. Net buyers of electricity have the opposite incentive: to lower the gas and electricity prices. I find evidence that Australian firms both recognize and act on the incentive to raise rivals electricity costs. However, this has only raised the daily gas price by an estimated 0.8 per cent on average. The incentive to raise rivals costs is small in Australia because the large firms tend to make only small net sales (or purchases) in the spot electricity market, due to their retail sales and forward contracts. However, given the evidence that firms act on this incentive, it may be of concern in other markets where there is limited vertical integration between generation and retail, and where firms sell greater volumes of electricity in the spot market. If policy makers wished to address this issue, they could require glass walls between the electricity and gas traders at each company, or require gas firms to divest their non-gas-fired electricity plants. However, the impact of such policies on the Australian gas market would be small.





## ***VIRTUAL GAS PIPELINE AS A PRUDENT SOLUTION IN GAS INFRASTRUCTURE INVESTMENT IN SAUDI ARABIA***

Dicky Suriakusumah, Saudi Aramco, +966 13 873 0179, dicky.suriakusumah@aramco.com

### **Overview**

The government of the Kingdom of Saudi Arabia has launched an ambitious program to displace more than 1 million barrel per day of liquid fuels across the sectors of power generation and water desalination, industry and agriculture by 2030, of which mostly will be replaced by natural gas. This program creates new gas demand in new locations.

From the supply side, Saudi Arabia has the world's eighth largest natural gas proved reserves, and Aramco will develop a large Jafurah gas project that will expand gas supply capacity ultimately by 2.2 billion standard cubic feet per day by 2036.

However, due to its capital-intensive nature, gas pipeline development to connect new demand centers and the supply carries a considerable risk because the demand centers are often located far away from the existing Master Gas System (MGS), multiple small volume customer bases with insufficient offtake guarantees, and uncertain future demand growth.

Virtual gas pipeline system can be a cost-effective solution compared to conventional gas pipeline to deliver gas to the new markets. It is an alternative system that allows gas transportation in the form of compressed natural gas (CNG) or liquefied natural gas (LNG). The main advantage of this system is its modularity and scalability which leads to flexibility in capital spending. The amount of investment and the level of capacity of the system can be aligned over time in line with the actual growth of future demand. Consequently, the upfront capital investment risk from under-utilized asset can be minimized.

### **Methods**

The study selects Al-Kharj and Sudair industrial cities in the Central region and Jeddah (2&3) industrial cities in the Western region as a case study of new natural gas markets to assess the benefit of virtual gas pipeline system as an alternative to a conventional gas pipeline system in gas infrastructure development in Saudi Arabia.

Gas demand is estimated based on existing economic activity in the selected industrial cities and is assumed to grow to reach the peak gas demand potential based on the total area of the industrial cities within 10 years period. The system's start year is assumed the same in 2025 although, in reality, virtual gas pipeline system can be installed in shorter period of time due to modular design and much less civil works.

CNG is selected as a technology in virtual gas pipeline system as the distances are within a range between 120-280 Km from the MGS system supply points. LNG is more capital intensive and considered as a more cost-effective means for long distance gas transportation beyond 400 Km.

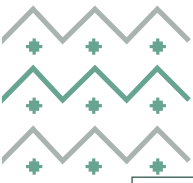
The study performs an assessment using Levelized Cost (LC) which represents Gas Throughput Tariff (expressed in \$/MMBTU) between the two alternatives. LC is defined as the present value (PV) of all costs of delivering gas from a supply point to end-users divided by the PV of annual gas throughput volumes, with the equation as follows:

$$LC = \frac{PV (costs)}{PV (gas\ throughput\ volume)} = \frac{\sum C_t / (1 + r)^t}{\sum V_t / (1 + r)^t}$$

where  $C_t$  represents cost (covering both capital and operating components) in year  $t$ ,  $V_t$  gas throughput in year  $t$ , and  $r$  denotes the required rate of return (applied discount rate) which is assumed at 10%. The sum is taken over the same length of project lifetime of 20 years for both options.







Most of the data and information is obtained from public domain. The study does not represent in any way of Saudi Aramco view on the gas market expectation and technical conventions.

### **Results**

The outcome of the study demonstrates that virtual gas pipeline solution has (1) lower capital outlay prior to project commissioning (upfront capex) in the range between \$100-500 million, which leads to (2) lower gas throughput tariffs of around 26% for gas supply to Al-Kharj Industrial City and 62% to Jeddah Industrial City. The tariff of gas supply to Sudair Industrial City is only 10% lower because of shorter distance and higher peak demand volumes. The result also suggests that (3) the economics of virtual gas pipeline solution is less susceptible to any uncertainty of future demand growth.

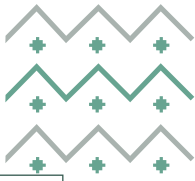
### **Conclusions**

Virtual gas pipeline system is a prudent solution in gas infrastructure development to supply remote demand centers due to lower upfront capital expenditures. It also offers a mechanism to penetrate new markets at lower gas throughput tariff and, over the period of time, to grow and consolidate sizeable gas demand to become anchor buyers to support the viability of the development of conventional gas pipeline infrastructure, thereby de-risking the investment. The old virtual gas pipeline system can then be moved to other location to develop a new gas market.

There are more than 20 industrial and economic cities in the Kingdom located away from the existing MGS network. Virtual gas pipeline solutions, either using CNG or LNG technology, can support the expansion of gas to these remote demand centers in a more cost-effective way,

Another application of the virtual gas pipeline system is in monetizing stranded marginal gas fields in Saudi Arabia and in serving as a gas system supply back-up during pipeline emergency situation.





## THE IMPACT OF DIGITAL FINANCIAL INCLUSION ON ENERGY CONSUMPTION IN SUB-SAHARAN COUNTRIES

Nancy Muvumbu Mukalayi, University of Pretoria, +27(73) 051 1346, [u16307314@tuks.co.za](mailto:u16307314@tuks.co.za)  
Roula Inglesi-Lotz, University of Pretoria, +27 (0)12 420 4504, [roula.inglesi-lotz@up.ac.za](mailto:roula.inglesi-lotz@up.ac.za)

Coal

### Overview

Given the importance of the energy consumption in the global warming, the consternation which concerns the energy system will always be relevant in the coming decades. According to the (IEA, 2021), the energy sector controls nearly three-quarters of the global CO<sub>2</sub> emissions which have increased global average temperatures to 1.1 °C with visible effects on climate. Meanwhile population is expected to grow up by almost 2 billion people to 2050, with increasing in income which will possibly increase demand for energy services. Also, to build up their national infrastructure, many emerging and developing countries are on the phase of an energy and emissions intense of urbanization and industrialization. Thereby, the new energy economy, the prosperous market opportunity for clean technology becomes a major new area for investment and international competition in advanced economies while in developing economies, people still lack access to electricity and clean cooking (IEA, 2021). For instance, according to the (IEA, 2021) the number of people without access to electricity is set to rise by 2% in 2021, with almost all the increase in the Sub-Saharan Africa. This energy gap has contributed to slow economic development and increased poverty. In recent years, the discussion around the implementation of an energy policy has taken place to deal with energy access challenges while limiting carbon emission, encouraging renewable energy and raising the possibility of tackling poverty. Indeed, how to promote the inclusive economic growth and reduce poverty has become a major subject of concern among both policy makers and the academia in the content. This has resulted in the initiative to promote financial inclusion in developing countries by the G-20 and the World Bank to reduce the level of poverty (Ozili, 2018). A developed and inclusive financial sector plays a great role by mobilizing savings and providing easy access to funds in consequence engendering growth (Alimi & Santos, 2015). All of this may require somehow the use of energy as the key to the production of goods and services.

### Methods

To evaluate the impact of DFI on energy consumption in SSA countries, different panel data econometric techniques are used. A framework dynamic panel regression model to capture the relationship between digital financial inclusion and energy consumption is specified as:

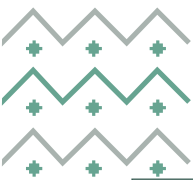
$$ec_{it} = \beta_0 + \beta_1 ec_{i,t-1} + \beta_2 dfi_{it} + \beta_3 gdp_{it} + \beta_4 trade_{it} + \beta_5 indus_{it} + \beta_6 urb_{it} + \beta_7 fdi_{it} + \gamma_i + \varepsilon_{it}$$

Where  $ec_{it}$  represents the dependent variable and which stand for energy consumption,  $ec_{i,t-1}$  represent the lagged dependent variable,  $dfi_{it}$  is the different proxies for digital financial inclusion,  $gdp_{it}$  represents gross domestic product per capita,  $trade_{it}$  represents trade openness,  $indus_{it}$  is a measure of industrialization,  $urb_{it}$  is the urbanization,  $fdi_{it}$  represent the foreign direct investment and  $\gamma_i$  is the unobservable country-specific characteristics.

The relationship between digital financial inclusion (DFI), energy consumption, economic growth is not always one way directed. It might include reverse causality especially in the case where a quality energetic or electric network in place boosts the development and the delivery of digital financial services. In fact, there exist already a certain level of endogeneity due the presence of the lagged dependent variable in the regression as an explanatory variable. These endogeneities potentially lead to biased estimated coefficients. Furth more, given large numbers of countries (N) relative to the time period (T) (Roodman, 2009) and given that the variables exhibit a strong persistence (Gnangnon, 2020). We propose to use a dynamic panel estimator based on GMM developed for such specifications suggested by (Arellano & Bond, 1991), and expanded to a system of equations with restrictions on the instrument by (Arellano & Bover, 1995) and (Blundell & Bond, 1998) to deal with these potential endogeneity. Compared to the first- differenced GMM estimator, the Sys-GMM is more efficient in the presence of persistent variable and weak instruments (Gnangnon, 2020). The check for the validity of the instruments Hansens test is applied to check for the

Open Rubric





validity of the instrument used in the estimations; the Arrelano-Bond test for the first-order autocorrelation AR (1) and the second-order autocorrelation AR(2) is also applied to check the consistency of the Sys-GMM estimator (Arellano & Bond, 1991) (Oosthuizen & Inglesi-Lotz, 2022).

## Results

Based on the Sys GMM result, we find mix effect of digital financial inclusion proxies on energy consumption. On one hand, the availability of digital financial services increases the energy consumption. While the usage dimension show mix result for example the beneficiaries of loan from commercial banks see their energy consumption decreases while deposit account holders at commercial banks see their energy consumption increase. Therefore, modern technology other than the one that has reduced the time and the cost of borrowers and credit from commercial bank has increased the energy consumption. In other word, innovative technology that allow banks to provide loans to individuals who would be excluded from loan if these new technologies do not exist is found supportive financing tool for energy efficiency.

## Conclusions

Given the results and the current green development tendency, any policy encouraging Digital financial inclusion should also consider energy consumption. The study provides one of the solution to enhancing energy efficiency. The government should reconsider digital financial inclusion as one of the solution to achieve the core agenda items for the economies to progress the world.

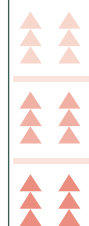
## References

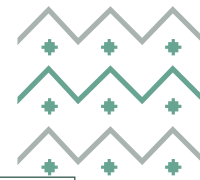
### References

- Alimi, & Santos, R. (2015). Financial deepening and economic growth : A System GMM Panel Analysis with application to 7 SSA countries. *MNPRA Paper*, 1-11.
- Arellano, M., & Bond, S. (1991). Some tests of specification for panel data: Monte Carlo evidence and an application to employment equations. *Review of Economic Studies*, 277-297.
- Arellano, M., & Bover, O. (1995). Another look at the instrument-variable estimation of the error-component models. *Journal of Econometrics*, 29-51.
- Blundell, R., & Bond, S. (1998). Initial conditions and moment restrictions in dynamic panel data models. *Journal of Econometrics*, 115-143.
- Gnangnon, S. K. (2020). Internet and tax reform in developing countries. *Information Economics and Policy*, 2-14.
- IEA. (2021). *World Energy Outlook 2021*. France: IEA.
- Oosthuizen, A., & Inglesi-Lotz, R. (2022). The impact of policy priority flexibility on the speed of renewable energy adoption. *Renewable Energy*, 426-438.
- Ozili, P. (2018). Impact of digital finance on financial inclusion and stability. *Borsa Istanbul Review*, 329-340.
- Roodman, D. (2009). How to do xtabond: An Introduction to Difference and System GMM in Stata. *The stata journal*, 86-136.



Coal





## *A Bayesian Approach to Analyse the Nexus Between the Environmental and Financial Factors to affect Energy Efficiency in the GCC Region*

Rozina Shaheen\*

\*Associate Professor, Finance Department, College of Business, Effat University, Saudi Arabia.  
 E-mail: roshaheen@effatuniversity.edu.sa

### Overview

Energy, being a significant input in the production process is considered an important element in the socio-economic development of a country. In this context, global economy is concentrating on attaining financial stability through increased energy efficiency and plummeting the energy intensity. Efficient use of energy enables the countries to improve their trade balance whereas it helps to reduce operating costs at micro level. Using energy-efficient techniques can reduce the environmental risks posed by the higher level of economic activity. Similarly, development of financial sector stimulates economic efficiency through the expansion in the financial activities (Sadorsky, 2010). Financial development helps to reduce cost of borrowing and financial risk, thereby creating transparency between lenders and borrowers. In addition, financial sector development facilitates the acquisition of sophisticated energy efficiency products and technology.

However, with the rapid economic development, the environmental degradation has become a focus point for the nations across the globe. The feedback effects from environment to economic growth have stimulated the researchers to investigate the reasons for environmental dilapidation and determine the solutions for environmental conservation. Many of these research studies are encircled around the environmental Kuznets curve (EKC) hypothesis (Grossman & Krueger, 1991) which elaborates the linkages between the environmental degradation and economic growth. Middle Eastern economies are heavily reliant on the energy-based revenues and any curb on the energy production directly affects their economic growth in the region.

Furthermore, financial system in the Middle Eastern region is technologically advanced with strong regulatory frameworks related to data protection, consumer protection, cybersecurity, and anti-money laundering. These regional characteristics provide a strong base to assess the existence of environmental Kuznets curve in the region and to examine the nexus between the financial sector development, economic growth, energy efficiency and Co2 emission in the region.

The relationship between the environmental quality and economic growth is explored by various studies such as Jaeger et al. (1995), Tucker (1995), Barbier (1997), Horvath (1997), Ansuategi et al. (1998), List and Gallet (1999), Stern and Common (2001), Roca (2003), Dinda and Coondoo (2006), Coondoo and Dinda (2008) and Akbostanci et al. (2009). However, this research is unique as it is first to examine the environmental Kuznets curve hypothesis for the oil based Middle Eastern economies while using a conditionally homogenous autoregressive model for the panel of Middle Eastern economies. This model considers homogeneity across the cross-sectional units with identical structural characteristics. The panel conditionally homogenous vector autoregressive specification permits the heterogeneity in the dynamic panel data set and evaluates the relationship between the observed heterogeneity across the units and their structural characteristics.

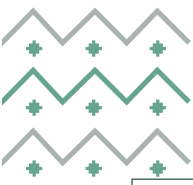
### Methods

Following Georgiadis (2012), we specify the model as follows:

$$y_{it} = \sum_{j=1}^p A_j(z_{it})y_{i,t-j} + \varepsilon_{it} \quad \varepsilon_{it} \sim^{i.i.d} (0, \Sigma_\varepsilon) \quad (i)$$

Where  $i = 1, 2, \dots, N$  shows the specific cross sectional unit,  $t = 1, 2, \dots, T$  is the time period,  $y_{it}$  is a  $K \times 1$  vector of endogenous variables,  $z_{it}$  is an  $M \times 1$  matrix of exogenous variables,  $A_j$  is a  $K \times M$  matrix of coefficients. Equation (1) is general form of panel vector autoregression but allows the heterogeneities across the units. In this case, time series are pooled and exogenous conditioning variables  $z_{it}$  are used to generate impulse responses. This approach presents the unit specific characteristics in observed heterogeneities and conditioning variables are key factors to affect the dynamics of the model. In PCHVAR, the coefficient matrices depend on the dynamic properties along with





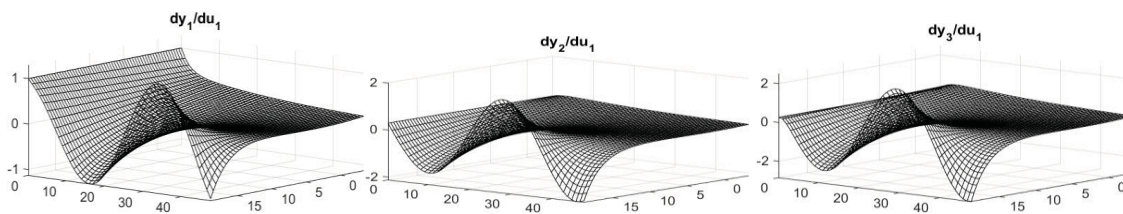
conditioning variables, therefore impulse responses are history dependents as well as the function of conditioning variables.

To investigate the impact of economic growth and financial sector development on the energy efficiency, this research considers a panel of five Middle eastern countries while using the annual data from 2001 -2020. Current research includes three sets of variables, the set of endogenous variables include energy intensity, carbon emission (CO<sub>2</sub>) and natural resource depletion, the set of exogenous variables contain gross domestic product (GDP) growth rate, financial technology, which is measured through number of ATMs, financial inclusion which is represented through access to credit and energy use (kg of oil equivalent per capita). These data sets are retrieved from the database of World Economic Outlook and International Financial Statistics

## Results

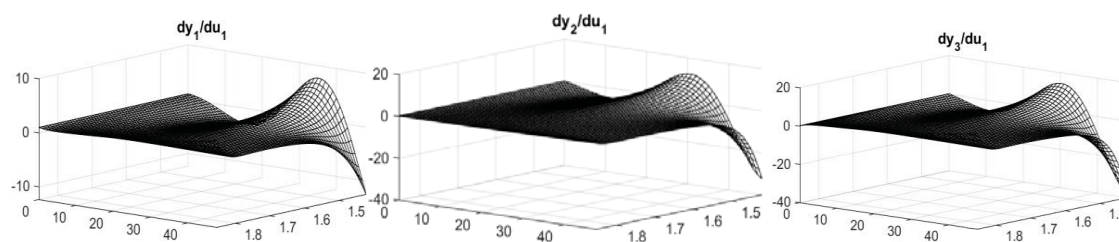
**Figure 1: Impulse Responses of the CO<sub>2</sub> Emission/Energy Intensity/Natural Resource Depletion PCHVAR Model - Varying GDP levels ...**

(a) at the Mean of ATMs



**Figure 2 : Impulse Responses of the CO<sub>2</sub> Emission/Energy Intensity/Natural Resource Depletion PCHVAR Model – Varying ATMs ...**

(a) at the Mean of GDP



## Conclusions

The analysis of impulse response functions reveals that in the short run, a one standard deviation positive shock in the GDP growth rate induces more CO<sub>2</sub> emission in the region. However, in the long run higher GDP growth leads to reduction in the CO<sub>2</sub> emission as countries become more economically sustainable which enables them to spend more on CO<sub>2</sub> emission technologies. Moreover, a positive shock in GDP growth rates induces positive impacts on the energy intensity and natural resource depletion in the short run, however this relationship becomes negative over the long-time horizons.

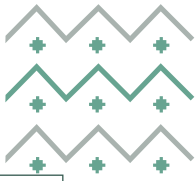
## References

- A. Ansuategi, E. Barbier, C. Perrings (1998), The Environmental Kuznets Curve, in: J.C.J.M. van den Bergh, M.W. Hofkes (Eds.), Theory and Implementation of Sustainable Development Modelling, Kluwer Academic, Dordrecht.,
- Dinda, S. (2004). Environmental Kuznets curve hypothesis: a survey. *Ecological economics*, 49(4), 431-455.
- Jaeger, W., Patel, S., Pinckney, T., 1995. Smallholder wood production and population pressure in East Africa: Evidence of an Environmental Kuznets Curve? *Land Economics* 71, 1–21 November.
- E. Barbier (1997), Introduction to the Environmental Kuznets curve special issue, *Environment and Development Economics*. 2 (1997) 369–381.
- J.A. List, C.A. Gallet (1999), The Environmental Kuznets Curve: does one size fit all?, *Ecological Economics*. 31 409– 423.
- D.I. Stern, M.S. Common (2001), Is there an environmental Kuznets curve for sulphur?, *Journal of Environmental Economics and Management*. 41 (2001) 162–178.



Coal





## [HOW CCS WORKS FOR FUTURE POWER MARKET IN JAPAN AND ITS IMPACT ON THE DEMAND OF FOSSIL FUELS ESPECIALLY COAL]

Hisanori Nei, Professor, National Graduate Institute for Policy Studies (GRIPS), +81-3-6439-6208, h-nei@grips.ac.jp

### Overview

There are about 80Mt coal and 50Mt natural gas consumed in the power market in Japan. While increasing concern about its carbon intensity, after Fukushima nuclear accident, coal and natural gas consumption has gradually increased because of stable price and supply sources.

80Mt import of thermal coal to Japan counts about 6% of total coal trading volume in the global market. 50Mt import of gas for power generation also counts about 15% of total LNG trading.

The main driver of coal and natural gas consumption expansion in Japan is relatively cheaper price than oil and cost competitiveness in the power market. Coal firing power generation is still one of the cheapest options of electricity just after nuclear.

In order to reduce CO<sub>2</sub> emission of fossil fuels firing power plant, there are two options. One is to improve efficiency of power generation, the other is to attach CCS.

In order to maintain stable supply of power to reduce the cost of CCS is an important factor to consider.

Based on several research and development projects we estimate the way to reduce the cost of CCS.

We need to set target of cost reduction for further introduction and commercialization of CC in Japan (in progress)

### Methods

I conduct interviews with executives of utility companies, trading houses, government officials to create potential scenarios together with literature reviews and empirical analysis of activities.

I also join a study team with experts from companies, research institute, governmental agencies to make relevant cost survey.

### Results

Cost of CCS based on conducting projects is around 6-8 yen/kWh

If we can reduce the cost 20% more, it will be below 5 yen/kWh by 2030 (under review)

It might be good enough to compete with the other power sources by 2030.

### Conclusions

Based on latest improvement of cost reduction for CCS, there are positive prospects to introduce in the power market in Japan.

But it requires more cost reduction.

We also need to consider the cost of supply security as well.

### References

Financing trends and challenges for coal-fired power plant, Paul Baruya, October 2016

On the climate change mitigation potential of CO<sub>2</sub> conversion to fuels, J. Carlos Abanades, Edward S. Rugin, Marco Mazzotti and Howerd J. Herzog. Energy Environ. Sci., 2017.10

Numerical Modelling on CO<sub>2</sub> Storage Capacity in Depleted Gas Reservoirs, Takashi Akai, Naoki Saito, Michiharu Hiyama and Hiroshi Okabe, Energies 2021

Coal







## The New Geopolitics of Energy Transition in the Middle East

Dr. Kaushik Deb, Senior Research Scholar, Center on Global Energy Policy, Columbia University +1 9173288595, [dk3208@columbia.edu](mailto:dk3208@columbia.edu)

Ahmed Alrashed, School of International and Public Affairs, Columbia University, +1 9176649962, [ama2335@columbia.edu](mailto:ama2335@columbia.edu)

1.6 Petroleum – Imports and Exports  
2.6 Natural Gas – Imports and Exports  
8.9 Energy and Environment – Other  
13.1 Energy Access and Geopolitics – Geopolitics of Energy

### Overview

The Middle East accounts for nearly half of the world's proven oil reserves and over 40% of proven gas reserves (bp 2022) and oil and gas still account for over 55% of the global primary energy consumption. The importance of the region has become even more evident as the conflict in Ukraine has brought to fore the very real prospect of Russian oil and gas supplies being disrupted either through extended sanctions or the potential of physical disruptions. Nevertheless, the region faces an uncertain future. In its latest World Energy Outlook (WEO 2021), the International Energy Agency forecasts a decline in global oil consumption after 2040 in its reference case, and even earlier in its climate constrained scenarios. BP Energy Outlook 2022 suggests that the oil demand will decline beyond 2025 in all of its scenarios (bp 2022a). Others such as the Organization of the Petroleum Exporting Countries (OPEC 2021) and the Institute of Energy Economics (IEEJ 2022) forecast a continued increase in oil consumption in their base cases, with demand rising by 0.6-0.7% p.a. until 2045/2050. This wide variation increases the uncertainty facing the region, and thus risks to the policy and commercial choices governments make in preparing for the next decades. These dynamics of the energy sector are playing out in parallel to the region's biggest demographic transition. UNICEF forecasts a 50% increase in population in the region between 2020-50, with the proportion of working age people to working age at its highest in history (UNICEF 2019).

This paper aims to analyze the role of the middle east in the global energy transition strategies, especially in the context of current global geopolitical events. It addresses a handful of major events among which are the shale oil revolution, COVID-19 disruption and the war in Ukraine. The key research questions that the paper addresses are the following:

1. What will be the role of the middle east in meeting global energy needs in the next decade and over the longer term in a net zero scenario?
2. How would the region adapt to the rebalancing of the global oil and gas markets?
3. What domestic transformations are necessary for countries in the middle east to adapt to a climate conscious and multi-polar world?

### Methods

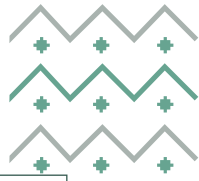
The paper provides analyses and arguments established on the grounds of the historical, current and foreseen facts that drive the geopolitics of energy in the region. The natural resources and the geographical location that the Middle East is endowed with represent a key element of the analysis in the paper. The geological constraints of the energy production and the logistical limitations of its transport will be deliberated in terms of their implication on the sector dynamics. Besides these un-moving variables, the paper will reflect on the economic conditions in the region, which is a critical factor to be examined in light of the ongoing economic restructuring effort in the leading countries in the Middle East.

At the forefront of the economic reform agenda in the region is the energy transition by which the countries pursue reducing the reliance on fossil fuel and move to cleaner sources of energy. Such reforms are expected to redefine the education, employment and social demands in the regions. In that light, the paper will also read through and analyze the energy transition agenda in an effort to rationalize and assess their impact on the global energy sector.

### Results

Oil and gas demand is continuing to rise rapidly as the world recovers from the COVID pandemic, especially in developing countries in Asia. On the other hand, investments in oil and gas in other regions have slowed down with increasing ESG pressure. Even growth in the supposedly supply elastic shale players has been tepid as price cycles have become more volatile. In addition, while investments in non-fossil fuels have grown considerably, they are not enough to meet the incremental energy demand nor technically viable to meet the baseload demand. In this context, the two of the largest oil producers in the region have already committed to increasing their production capacity over the next decade. Saudi Arabia has planned to increase its maximum sustained production capacity to 13.4 mb/d





(million barrels a day) by 2027, while the UAE is targeting a capacity of 5 mb/d by 2030. In the case of natural gas, Qatar is expanding its LNG production capacity to 126 million tonnes per annum by 2025, and likely to reclaim its position as the world's largest LNG exporter then. Thus, the share of the region in meeting global oil and gas demand is likely to rise in every scenario until 2050.

Second, the current global crunch caused by the sanctions on Russian oil and gas is expected to lead to long-term cooperation between the major oil and gas exporters in the Middle East and the oil and gas importing countries, especially the European countries. In the medium to long term, North American and European buyers could permanently pare back purchases of Russian supply to insulate against the weaponization of Russian energy exports. In the medium term, this leaves the Middle East to play a key role in filling the remainder of the hole from lost Russian supply. Some of the largest suppliers of crude to the EU before the Russian war in Ukraine included Iraq, Saudi Arabia and Qatar. Other countries such as the UAE and Kuwait will also have an opportunity to sell meaningfully greater volumes to Europe. However, this would require a redirection of volumes currently exported elsewhere, including perhaps growth markets in Asia such as China and India. The issue of shifting market share could become important over the long term. Oil demand in Europe has declined by 17 percent between 2010 and 2020, and has likely already peaked. On the other hand, growth in developing countries in Asia, and particularly in China and India, continues to be robust. In the International Energy Agency World Energy Outlook 2021, growth in oil and gas consumption in this region far exceeds everywhere else, both today and in all scenarios (IEA 2021). In the BP Energy Outlook 2022 as well, oil demand in the emerging economies is expected to rise to be almost 80% of the global oil demand by 2050 (bp 2022a). Thus, over time the large Middle Eastern countries would want to maintain their market share in Asia, also because these producers have historically been able to charge a higher price in the Asian market compared to elsewhere.

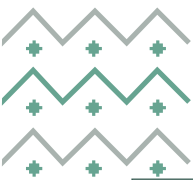
In recognition of the two challenges, namely potential pressure on energy sector revenue, and a growing and young population, nearly all the countries in the Middle East have announced strategies for some form of economic restructuring and reform with a focus on economic diversification and a shift away from hydrocarbon dependence. Net zero commitments by the UAE and Saudi Arabia are the latest in a series of energy policy announcements in the region, following on from Vision 2030, Abu Dhabi Economic Vision, New Kuwait 2035 among many others that aim to reform the energy sector, diversify away from hydrocarbon, and increase employment opportunities including in new energies. The region is uniquely positioned to finance the development towards decarbonized economies with large sovereign wealth funds and major national companies. However, with demand for hydrocarbons slowing down and potentially peaking in the next decade, leading states in the region, including Saudi Arabia and the UAE, have decided to accelerate their transitions toward lower carbon intensive production, economic diversification, and a leadership position globally in carbon capture and sequestration as well as creating legal global roles in the production and distribution of hydrogen. At the same time, intensified efforts to ensure sustainability of hydrocarbon demand by creating consumption channels where hydrocarbon is economically and environmentally competitive remain central to national strategies. There could also be a role for private and international capital in financing this transition. Ensuring that strategies for economic diversification away from fossil fuel exports, and within the energy sector towards non-fossil fuels, is central to maintaining political and economic stability in the region. In particular, this would require a significant ramp up in educational and employment opportunities, to ensure that this trend manifests itself as a demographic dividend and not a demographic burden.

### **Conclusion**

The Middle East will continue to be a key supplier of the global energy demand. This is driven by the production capacity expansion efforts in the leading producing countries in the Middle East, as opposed to reduced investment in hydrocarbon production in other regions owing to the ESG pressure. Also, there is likely to be a rebalancing of regional oil and gas markets as the world adapts to the crisis in Europe. In case the Russian oil stops flowing to the EU, there is a possibility for Middle Eastern producers to shift their oil export from developing economies in Asia to Europe, which has a long-term effect that needs to be considered.

Moreover, the success of a managed energy transition in the middle east would not just be necessary for the continued stability of the region, but also its ability to meet global energy demand. The leading Middle Eastern oil producing countries are committed and well positioned to offer low carbon energy to the world. This is envisioned to be achieved by accelerating the carbon capture and sequestration technologies and the production and distribution of hydrogen. The competitive advantage of the Middle East in terms of achieving these goals is manifested in the financing capabilities through sovereign wealth funds that rank among the largest worldwide, beside the low carbon intensity on the oil production process.





## References

bp (2022). bp Statistical Review of World Energy 2021 | 70th edition, bp, <https://www.bp.com/content/dam/bp/business-sites/en/global/corporate/pdfs/energy-economics/statistical-review/bp-stats-review-2021-full-report.pdf>

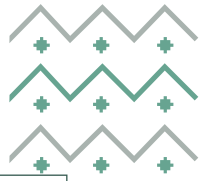
bp. (2022a). *BP energy outlook 2022*. Retrieved July 13, 2022, from <https://www.bp.com/content/dam/bp/business-sites/en/global/corporate/pdfs/energy-economics/energy-outlook/bp-energy-outlook-2022.pdf>

IEA (2021), World Energy Outlook 2021, IEA, <https://www.iea.org/reports/world-energy-outlook-2021>

IEEJ (2022), IEEJ Outlook 2022-Energy Supply and Demand Outlook by 2050. IEEJ <https://eneken.ieej.or.jp/data/9937.pdf>OPEC (2021), World Oil Outlook 2021, OPEC, [https://www.opec.org/press-room/download/res/pdf\\_delivery.php?secToken2=442de4be7fd406d08ec122a309653592d8f06e](https://www.opec.org/press-room/download/res/pdf_delivery.php?secToken2=442de4be7fd406d08ec122a309653592d8f06e)

UNICEF (2019), MENA Generation 2030, UNICEF, <https://data.unicef.org/resources/middle-east-north-africa-generation-2030/>





## **[DEPENDENCE BETWEEN THE GCC ENERGY EQUITIES AND SELECT GLOBAL ENERGY MARKETS: EVIDENCE FROM WAVELET ANALYSIS]**

[Mohammed Alkathery, The Unified National Platform in Saudi Arabia, 0556809090, moh.a.alkathery@gmail.com]

[Kausik Chaudhuri, University of Leeds, +44(0)113 343 0192, K.Chaudhuri@lubs.leeds.ac.uk]

[Muhammad Ali Nasir, University of Leeds, +44(0)113 343 0192, M.A.Nasir@leeds.ac.uk]

### **Overview**

In this study, we developed a dependence structure using a multiscale approach of wavelets to investigate the impact of global clean energy production, oil price and CO<sub>2</sub> emission on the energy stock markets of the largest three oil exporters in the GCC region: Saudi, UAE and Kuwait. Our key findings indicate that the three global energy markets are weakly and positively correlated with the GCC energy stock prices at lower frequencies (higher scales). Besides, at the same level of frequencies, we found that changes in the global clean energy production index and CO<sub>2</sub> emission price positively influences the three GCC energy stock prices. Oil price is a stronger moderator for the three GCC energy equities at lower frequencies relative to other variables, especially for Kuwait's energy stock price. We also discover that the Abu Dhabi energy index is more sensitive to swings in the three perspective markets compared to Saudi and Kuwait energy markets. These findings carry important implications and guidelines for policymakers, portfolio managers and scholars who attempt to understand the dynamic nexus between GCC energy sectors and global energy markets behaviour.

### **Methods**

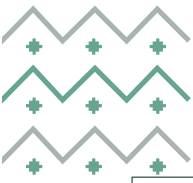
We follow Percival and Walden's (2000) and use the maximal overlap discrete wavelet transforms (MODWT) to estimate the coefficients of multiscale wavelet correlation (WC) and wavelet cross-correlation (WCC) among the respective variables. Up to six levels of wavelets were performed to cover from daily to monthly frequencies. The timescales determined as scale 1 (1-2 days), scale 2 (2-4 days), scale 3 (4-8 days), scale 4 (8-16 days), scale 5 (16-32 days) and scale 6 (32-64 days). For the cross-correlation, a lag of 22 days has been selected, like the approximate number of trading days per month.

### **Results**

The wavelet correlation (WC) analysis produces two kinds of results: (i) the correlation of the GCC energy equities with the three respective variables: global clean energy production index, oil price and CO<sub>2</sub> emission price for the lower timescales (high frequencies) is near to zero; and (ii) there is a positive correlation between the pairs for the higher timescales (low frequencies). For the wavelet cross-correlation analysis (WCC), we prove that there is no lead/lag relationship between the respective pairs at low scales. For the higher scales, we find that changes in both the clean energy production index and CO<sub>2</sub> emission price positively leads the three GCC energy markets. While oil price can only influence Kuwait energy stock price at the same level of scales. Overall, the wavelet correlation of the Abu Dhabi energy index was more sensitive to changes in the three global energy indexes relative to Saudi and Kuwait energy indexes. Besides, oil price correlation effects on the three GCC energy equities are stronger than the correlation effects of clean energy production and CO<sub>2</sub> emission price.

### **Conclusions**

Using a multiscale approach of wavelets, we develop a dependence structure to investigate the impact of global clean energy production, oil price and CO<sub>2</sub> emission on the energy stock markets of the largest three oil exporters in the GCC region; Saudi, UAE and Kuwait. The purpose is to evaluate the effect of the recent boom in the global renewable energy industry and the EU ETS on the GCC conventional energy stock prices. Our findings indicate that the three global energy markets are weakly and positively correlated with the GCC energy stock prices at lower frequencies (higher scales). Besides, at the same level of frequencies, we found that changes in the global clean energy production index and CO<sub>2</sub> emission price positively influences the three GCC energy stock prices. Oil price



is a stronger moderator for the three GCC energy equities at lower frequencies relative to other variables, especially for Kuwait's energy stock price. We also discover that the Abu Dhabi energy index is more sensitive to swings in the three perspective markets compared to Saudi and Kuwait energy markets. These findings carry important implications and guidelines for policymakers, portfolio managers and scholars who attempt to understand the dynamic nexus between GCC energy sectors and global energy markets behaviour. Future studies can explore these relationships over the long-term using other statistical techniques. Future studies are encouraged to consider the potential impact of the recent US shale oil production on oil-exporting economies.

### References





## Enhancing Decarbonization of Power Generation Through Electricity Trade: Eastern Mediterranean and the Middle East Region

Constantinos Taliotis\*, Marios Karmellos, Nestor Fylaktos, Theodoros Zachariadis  
\*The Cyprus Institute, +357 22 397 524, c.taliotis@cyi.ac.cy

### Overview

The climate emergency is one of the most important challenges of modern society. A transition to low carbon economies can mitigate the impact of climate change but requires investments at an unprecedented pace and scale. However, not all regions in the world are on a path to decarbonization. Most countries in the Eastern Mediterranean and Middle East (EMME<sup>1</sup>) region are far off the trajectory required to achieve the targets set by the Paris Agreement. An unquestionable indication of this is that the renewable energy share in total electricity generation of the EMME region was limited to 12% in 2019 [1].

Several model-based assessments have been conducted on the topic of increased renewable energy deployment and decarbonization of the region. Examples include national-focused analyses [2]–[4], but also efforts with a regional perspective [5]–[7]. Regional analyses can provide a more holistic overview in regard to regional cooperation and energy commodity trade. However, certain gaps have been identified in existing literature with regional focus in terms of temporal and technological detail.

The present effort consists of the first attempt to develop a fully open-source EMME energy systems model with grid interconnector representation. It aims to explore the potential for electricity trade across the region and how this can unlock renewable energy resources and assist in cost-effective decarbonization efforts. It provides new insights on the potential environmental and economic benefits offered by increased regional collaboration in the energy sector.

### Methods

The EMME electricity supply model presented here is developed within a cost-optimisation model [8]. It adopts an open-source framework, in order to ensure transparency in the input data and assumptions. The model's objective is to minimise the cost of satisfying externally defined demands for energy services, considering a range of assumptions, such as on technology cost and fuel price projections, fossil fuel and renewable energy resource availability. It has been used in the past to conduct analyses at the global, regional and national level [9].

The seventeen countries of the region are represented in the model as separate systems that can trade electricity with their neighbouring systems either through existing or future grid interconnections. The model is populated with information from publicly available sources. This includes data on existing and planned generation and grid interconnection capacity, electricity demand projections, international fuel price projections<sup>2</sup>, and technoeconomic assumptions on electricity generation and storage technologies. However, data are scarce for some countries. This limitation can be alleviated in future improvements of this work through collaboration with interested national authorities.

A set of scenarios is developed to generate insights at regional and national level, highlighting the advantages of EMME-wide policies instead of individual national roadmaps. The present analysis assesses the following scenarios:

- A. **Reference Trade:** In this scenario, electricity interconnections are limited to existing projects. Trade is allowed to occur if deemed cost-effective using this infrastructure.
- B. **Enhanced Trade:** In this scenario, grid interconnections under discussion are allowed to be invested in, thus enabling a higher volume of electricity exchange across the region.
- C. **Net Zero with Reference Trade:** Building on the Reference Trade scenario, this case implements a net-zero carbon dioxide emission target across the EMME region. This scenario shows the additional investments needed to align the region with the Paris Agreement targets and limiting global warming to 1.5°C.
- D. **Net Zero with Enhanced Trade:** Similar to above, a net-zero carbon dioxide emissions target is implemented, while allowing for investments in new grid interconnections to occur. A comparison with the Reference Trade-Net Zero case can show potential cost savings enabled by enhanced trade.

<sup>1</sup> The EMME region is defined here to consist of Bahrain, Cyprus, Egypt, Greece, Iran, Iraq, Israel, Jordan, Kuwait, Lebanon, Oman, Palestine, Qatar, Saudi Arabia, Syria, Turkey, and United Arab Emirates.

<sup>2</sup> Even though some countries may provide fuel to generation facilities at a lower cost, international fuel price projections are used for the entire region. This is done to assess development pathways under perfect market conditions without any market distortions.







## Results

Driven by an assumed continuous increase in electricity demand, renewable energy deployment is projected to increase substantially in all scenarios. In the cases where no carbon dioxide emission targets are implemented, the renewable energy share in generation increases to 60% by 2030, 88% by 2040 and 93% by 2050. An increase in variable renewable energy needs to be accompanied by electrical storage capacity, which is projected at 89-93 GWh in 2030, 614-626 GWh in 2040 and 975-1,011 GWh in 2050. Availability of additional grid interconnection capacity increases the level of trade across the EMME region (Figure 1). The total level of electricity exchange is higher by 37 TWh in 2030, 70 TWh in 2040 and 92 TWh in 2050, when the Reference and Enhanced Trade scenarios are compared. This illustrates the considerable potential for investments in grid interconnections.

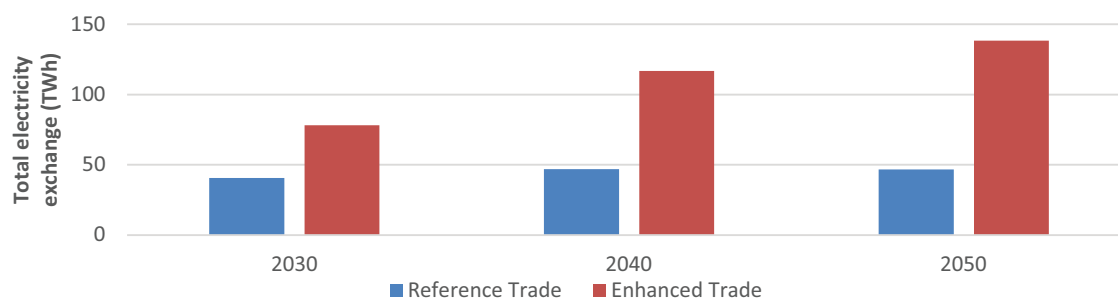


Figure 1. Level of total intraregional electricity exchange projected for the Reference and Enhanced Trade scenarios.

Even though the planned grid interconnection capacity is limited until 2050 to currently identified projects, electricity trade has a direct effect on greenhouse gas emissions. Cumulative carbon dioxide emissions in the period 2021-2050 decrease from 9.9 Gtons in the Reference Trade to 9.7 Gtons in the Enhanced Trade scenario. If further grid interconnections other than those already discussed are considered, the difference between the two cases may increase.

The analysis clearly indicates that electricity exchange can assist in a more cost-effective achievement of the Paris Agreement targets. When the two scenarios with net-zero emission targets are compared, the overall system costs decrease when enhanced electricity trade is allowed (Figure 2). Specifically, the total system cost reduces by 6% in the decade 2041-2050; this is the period in which emission targets are implemented.

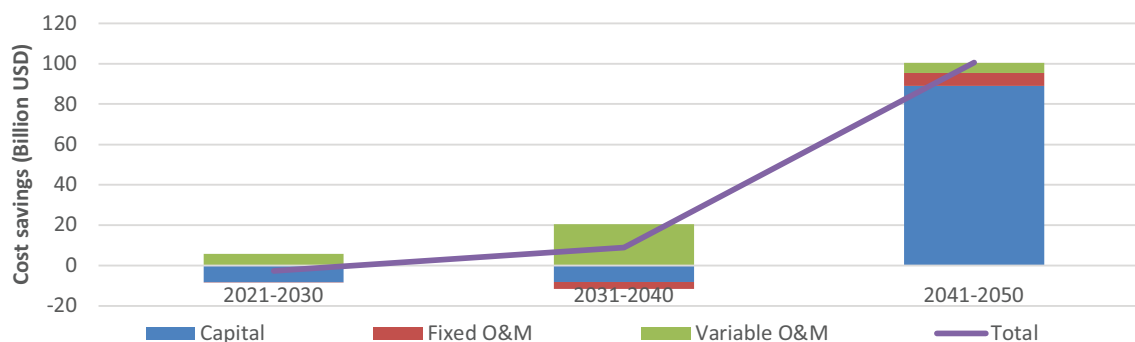


Figure 2. Electricity supply system cost savings achieved through enhanced trade in the Net-Zero variants of the scenarios. Negative values indicate higher cost in the Enhanced Trade compared to the Reference Trade case.

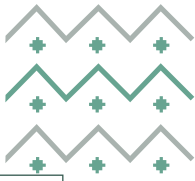
## Conclusions

Electricity trade across the EMME region offers multiple benefits. It can lead to a decrease in greenhouse gas emissions, while reducing the financial requirements for generation technologies. Additional to national energy and climate plans, regional cooperation for the formulation of a regional action plan can promote coordinated efforts in this front.

Regional cooperation in the identification of the most cost-effective grid interconnection projects that can unlock major renewable energy potential should be pursued. Similarly, an increase beyond the planned grid interconnection capacity should be investigated.

Renewable energy investments are projected to increase across the EMME region in all scenarios. These need to be accompanied by investments in storage technologies, while they can be assisted by availability of grid interconnections. A favourable regulatory environment that supports investments in these technology options is needed to achieve decarbonization.

Operation of a regional electricity market entails the existence of a level playing field across all EMME countries. Since direct or indirect fuel subsidies distort the market, this is an area that requires further political action in many EMME countries, where electricity and fuel subsidies are still in place.



## References

- [1] US EIA, 'International', *U.S. Energy Information Administration*, 2021. <https://www.eia.gov/international/data/world/electricity/electricity-generation?pd=2&p=00000020000020000200000000400fvu&u=0&f=A&v=mapbubble&a=-&i=none&vo=value&&t=C&g=none&l=249-0g00800000401000008003902g00000000200051000100g&s=315532800000&e=1546300800000> (accessed Jan. 15, 2021).
- [2] A. Kilickaplan, D. Bogdanov, O. Peker, U. Caldera, A. Aghahosseini, and C. Breyer, 'An energy transition pathway for Turkey to achieve 100% renewable energy powered electricity, desalination and non-energetic industrial gas demand sectors by 2050', *Solar Energy*, vol. 158, pp. 218–235, Dec. 2017, doi: 10.1016/j.solener.2017.09.030.
- [3] M. Bohra and N. Shah, 'Optimizing Qatar's energy system for a post-carbon future', *Energy Transit*, vol. 4, no. 1, pp. 11–29, Jun. 2020, doi: 10.1007/s41825-019-00019-5.
- [4] IRENA, 'Renewable Energy Outlook: Egypt', International Renewable Energy Agency, Oct. 2018. Accessed: Mar. 30, 2020. [Online]. Available: <https://www.irena.org/publications/2018/oct/renewable-energy-outlook-egypt>
- [5] World Energy Council, 'World Energy Scenarios 2019: Exploring Innovation Pathways to 2040', London, United Kingdom, 2019. [Online]. Available: <https://www.worldenergy.org/publications/entry/world-energy-scenarios-2019-exploring-innovation-pathways-to-2040>
- [6] S. Bohn, M. Agsten, A.-K. Marten, D. Westermann, I. Boie, and M. Ragwitz, 'A pan-European-North African HVDC grid for bulk energy transmission — A model-based analysis', in *2014 IEEE PES TD Conference and Exposition*, Apr. 2014, pp. 1–5. doi: 10.1109/TDC.2014.6863272.
- [7] A. Aghahosseini, D. Bogdanov, and C. Breyer, 'Towards sustainable development in the MENA region: Analysing the feasibility of a 100% renewable electricity system in 2030', *Energy Strategy Reviews*, vol. 28, p. 100466, Mar. 2020, doi: 10.1016/j.esr.2020.100466.
- [8] M. Howells *et al.*, 'OSeMOSYS: The Open Source Energy Modeling System: An introduction to its ethos, structure and development', *Energy Policy*, vol. 39, no. 10, Art. no. 10, Oct. 2011, doi: 10.1016/j.enpol.2011.06.033.
- [9] F. Gardumi *et al.*, 'From the development of an open-source energy modelling tool to its application and the creation of communities of practice: The example of OSeMOSYS', *Energy Strategy Reviews*, vol. 20, pp. 209–228, Apr. 2018, doi: 10.1016/j.esr.2018.03.005.





Position of Petroleum Resources in the Africa's Gulf of Guinea Region: Environment, Economy and Development

Babagana Abubakar, K. Computers, +2348062220179, babaganabubakar2002@yahoo.com

## Overview

Despite the quantity of petroleum reserves and ongoing petroleum exploration in the Gulf of Guinea region but pollution of the Atlantic Ocean by petroleum products, gas flaring and piracy on Oil vessels in the region is on the increase. As a result several suggestions and recommendations were proffered in this research that if adopted and implemented it can reduce the level of pollution, reduce pirate attacks on oil vessels and also promote national economies of nations in the region.

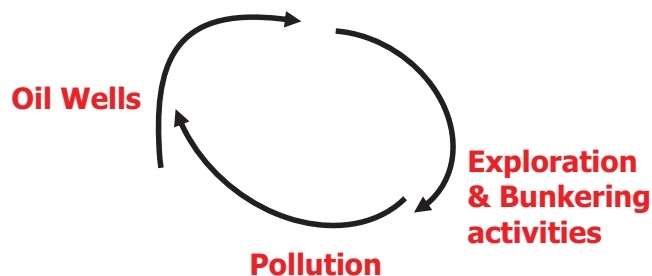
### Introduction:

The Gulf of Guinea region is in Africa and is located within the West and Central African coast lines and the surrounding territorial waters of the Atlantic Ocean. Geographically speaking, the Gulf of Guinea is made up of the maritime area located in the western part of the African continent and north-eastern part of the Atlantic Ocean to the east of the Greenwich meridian line. The International Hydrographic Organization defines the southwest extent of the Gulf of Guinea as "A line running Southeastward from Cape Three Points in Western region Ghana (4.744°N 2.089°W) to Cape Lopez in Gabon (0°38'S 8°42'E)". The United Nations Permanent Advisory Committee on Security Issues in Central Africa (UNSAC) recognizes all the coastal countries from Angola to Cote D'ivoire (Ivory Coast) making the following countries as member states; Angola, Ivory Coast, Ghana, Togo, Benin, Nigeria, Cameroon, Equatorial Guinea, Gabon, Sao Tome and Principe, Democratic Republic of Congo and the Republic of Congo.

#### 1. Pollution in the Gulf of Guinea by petroleum products:

The ongoing petroleum exploration activities within this gulf region in countries like the Equatorial Guinea, Sao Tome and Principe, Gabon, Nigeria, Angola and others are continuously causing oil spillages in the process of drilling, bunkering and discharging of petroleum products in the Atlantic Ocean. In fact, these petroleum exploration activities and the oil spillages assumes the form of a vicious circle as illustrated below:

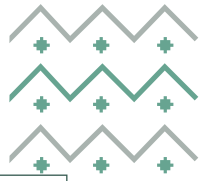
*Chart 1: Showing the vicious cycle of the petroleum exploration activities:*



In view of the above the region keeps recording incessant incidents of Ocean Pollution through increasing oil spillages resulting in rapid decline in fish, plankton, shrimps, crabs, Cray fish and other sea lives along the Coasts of this Gulf facing the Atlantic Ocean.

#### 2. Piracy in the Gulf of Guinea region & oil tankers:





Pirates in the Gulf of Guinea are often associated to stealing of oil cargo and or kidnapping for ransoms. The culprits are often heavily armed criminal enterprises, In 2012, the International Maritime Bureau, Oceans Beyond Piracy and the Maritime Piracy Humanitarian Response Program reported that the number of oil vessels attacks in West African which forms 50 % of the total area of the Gulf of Guinea by pirates had reached a world high, with 966 seafarers attacked during the year. Recent attacks have extended further out at sea beyond mostly Nigeria's national jurisdiction in the ocean by focusing largely on oil-laden vessels, to steal the petroleum product. This explains why the Nigerian president during a summit on anti-corruption in London on the 12th May, 2016 call on the international community to declare stolen oil as illicit commodity just considered to be a blood oil just like the case with the blood diamond. The Gulf of Guinea accounted for 427 of the 1434 attacks in African waters between 2003 and 2011. The frequency of attacks in this region, while not as high as those of the Somali coast, is however on the rise.

. Suggestions/recommendations:

1. The United Nations Office for Outer Space Affairs (UNOOSA) should use its capacity to influence relevant stakeholders and governments in the region to accept and consider the use of satellite technology for an effective surveillance and monitoring in order to avert possible pollution time.
2. Fighting piracy through space technology application: The use of modern satellite technology such as the Automatic Identification System (AIS) (an automatic tracking system used on ships and by vessel traffic services (VTS) for identifying and locating vessels by electronically exchanging data with other nearby ships, AIS base stations, and satellites) can help locate pirates before or even after Ship attacks or hijacks which gives room to arrest or confront this pirates at the right time and on the right target if so happens.

### Methods

Both quantitative and qualitative methodologies were used in the process.

Questionnaires were administered on the target audience together with interviews of selected people and communities.

### Results

Result reidentified the types and nature of problems as well as their causes.

### Conclusions

This research work identified the Africa's Gulf of Guinea region as one of the World's rich nations blessed with natural resources with petroleum as the main resources, but yet human made challenges keeps underdeveloping the region with potential risks of affecting the global economy and safety as a whole. The Authors recommendations in this research work has great potentials of drastically reducing the menace and improve on the global safety and economy.

### References

1. Alessi, C. (2012), "Combating Maritime Piracy", Council on Foreign Relations, 13 March, <http://www.cfr.org/france/combating-maritime-piracy/p18376>
2. United Nations Industrial Development Organization, "Gulf of Guinea: Water Pollution Control and Biodiversity Conservation," [www.unido.org/en/doc/3637](http://www.unido.org/en/doc/3637).
3. Sachs, Jeffrey, and Andrew Warner, 1995, "Natural Resource Abundance and Economic Growth," Harvard Institute of Economic Research Discussion paper, No. 517 (Cambridge, Massachusetts: Harvard Institute for International Development).
4. Anene, L. (2006) 'Gulf of Guinea: A Growing Strategic Profile', Nigerian Army Quarterly Journal, 2(1):39-51.
4. Dietrich, J. (2004) 'The Gulf of Guinea and Global Oil Market: Supply and Demand', in R. Traub-Merz and D. Yates (eds.) Oil Policy in the Gulf of Guinea: Security and Conflict, Economic Growth, Social Development. Bonn: Friedrich Ebert-Stiftung.





## **Nuclear Energy in Emerging Markets, MENA and the impact of Energy Transition**

Yagyavalk Bhatt, King Abdullah Petroleum Studies and Research Center, +966542494084, [yagyavalk.bhatt@kapsarc.org](mailto:yagyavalk.bhatt@kapsarc.org)  
Jitendra Roychoudhury, King Abdullah Petroleum Studies and Research Center, +966532846492, [jitendra.roychoudhury@kapsarc.org](mailto:jitendra.roychoudhury@kapsarc.org)

### **Overview**

For emerging markets of India, ASEAN and MENA, energy consumption is expected to increase with the rise in economic development. Currently, their energy mix is dominated by fossil fuels such as oil and coal, which has to be mostly imported and makes them dependent on global energy markets which have their own drivers. However, these countries are also committed to clean energy growth through net zero commitments, which leads to investments in non-fossil fuel energy sources such as renewable energy and nuclear. The non-fossil fuel energy sources such as nuclear and renewables will not only help them achieve its climate goals but could also increase their ability to develop local content value chains around labor, material and related activities. This paper looks at the impact of the growth in nuclear energy from the perspective of economic development and focuses on the markets of India, ASEAN, and MENA to understand common strains and policy inputs which have helped shape their development and what are the policy lessons to be learnt.

### **Methods**

The paper provides analyses and arguments established on the grounds of the historical, current and foreseen facts that drive the Nuclear energy uptake in India, South Asia and MENA region. The non-fossil fuel energy sources such as nuclear and renewables will not only help them achieve its climate goals but could also increase their ability to develop local content value chains around labor, material and related activities. This paper looks at the impact of the growth in nuclear energy from the perspective of economic development and focuses on the markets of India, ASEAN, and MENA to understand common strains and policy inputs which have helped shape their development and what are the policy lessons to be learnt.

### **Results**

There has been pressure both internationally and internally on energy sector due to climate change and energy security respectively. Nearly all the countries have announced strategies for mitigating Climate change and reduce their dependence on fossil fuels putting them one step closer to the energy secure future. Ensuring that strategies for economic diversification away from fossil fuel imports, and within the energy sector towards non-fossil fuels, is central to maintaining political and economic stability in the Asian and MENA region. The non-fossil fuel energy sources such as nuclear and renewables will not only help them achieve its climate goals but could also increase their ability to develop local content value chains around labor, material and related activities. This paper will analyse the Nuclear policies in the respective geographies and will highlight the learning from it.

### **Conclusions**

The success of a clean energy transition in the form of nuclear energy in India, ASEAN and middle east would serve as learning platform.





## ***Fourth IV Generation Nuclear Reactors as Sustainable and Safe Energy Resources***

Moustafa Aziz

Nuclear and radiological Safety Research Center

Atomic Energy Authority

3 Ahmed Alzomer St. , 11762

Nast City , Cairo

Phone : 201223421978 /email : [moustafaai@yahoo.com](mailto:moustafaai@yahoo.com)

### **Overview**

Fourth generation nuclear reactors are highly advanced and innovative reactors, which are expected to enter service by 2030. The development includes several areas namely, sustainability ,nuclear safety and reliability, economy and proliferation resistance. Theses reactors contain modern designs and innovative systems to resist nuclear accidents. They contain Inherent and passive safety systems that do not require electricity or intervention of the reactor operator. The efficiency of the plant ranges between 45-50 % compared to the current generation (32-36 %). The spent fuel in most types is recycled and reused again to support fuel availability and sustainability of nuclear fuel. They are considered multi-use energy systems used in the production of electricity, hydrogen, water desalination and the production of heat required for heating and various industrial processes. This generation of reactors has less hazardous impact on the environment than that of the current reactors.

### **Methods**

Generation IV International Forum (GIF) was created in 2001 which adopts a new , Innovative and evolutionary design reactors with advanced control systems for the next generation. The Forum established aims, goals and roadmap for the new reactors. These modifications concentrated on four classified areas: sustainability, safety and reliability, economic competitiveness, and proliferation resistance.[ 1,2,3]. So expanding energy use utilizing today's mix of production options, however, will continue to have adverse environmental impacts and potential long-term consequences from global climate change. Thus increasing the use clean, safe, and cost-effective energy supplies is a must. Prominent among these supplies is nuclear energy. Fourth Generation nuclear reactors could be used as sustainable and safe energy resources. There are currently approximately 440 nuclear power plants in operation around the world, producing approximately 13% of the world's electricity—the largest share provided by any non-greenhouse-gas-emitting source.

Safety of nuclear reactors means the protection of people and the environment against radiation risks, and the safety of facilities and activities that give rise to radiation risks. Safety of nuclear reactors includes safety of nuclear installations, radiation safety, the safety of radioactive waste management and safety in the transport of radioactive materials. Sustainability is the ability to meet the needs of the present generation while enhancing the ability of future generations to meet society's needs of energy and electricity.

Six nuclear reactors are chosen to satisfy these goals for generation IV nuclear reactors, these reactor are: very-high-temperature gas cooled reactors , molten salt reactors, supercritical-water-cooled reactors , sodium-cooled fast reactors , gas-cooled fast reactors , lead-cooled fast reactors

### **Results**

A Nuclear Energy system can be characterized as a sustainable system if it meets certain requirements. These include availability and security of the supply of natural resources, economic , operation safety, effective proliferation resistance, and adequate infrastructure, including the effective functioning of institutions for legal responsibility, the regulatory role, and technical and scientific support .







## Conclusions

- Generation IV Nuclear reactors will be multipurpose reactors [ electricity , hydrogen , water declination and heat production

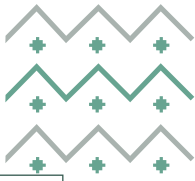
-Generation IV Nuclear Reactors implement high technology systems and innovative design to improve and strength, safety and economic feasibility and sustainability of nuclear reactors.

- Generation IV nuclear reactors will be safer, economic and more reliable.

## References

- [1] GIF, 2014, *Technology Roadmap Update for Generation IV Nuclear Energy System*, GIF-IV (The Generation IV International Forum) and the OECD Nuclear Energy Agency )
- [2] Accident Tolerant Fuel Concepts for Light Water , Reactors, International Atomic Energy Agency , (IAEA) - TECDOC-1797, IAEA, Vienna (2016).
- [3] Nuclear Power and Secure Energy Transitions , International Energy Agency, June 2022
- [4] Adapting the Energy Sector to Climate Change, International Atomic Energy agency , Vienna ,2019
- [5] M. J. DRISCOLL and P. HEJZLAR  
Reactor Physics Challenges in Generations IV Nuclear Reactor design  
Nuclear Engineering and technology, Vol. 37 No.1, February 2005
- [6] IAEA Nuclear Energy Series. No. NG-T-3.19 , Planning Enhanced Nuclear Energy Sustainability: An INPRO Service to Member States, Analysis Support for Enhanced Nuclear Energy Sustainability (ASENES), IAEA , July 2021
- [7] Nuclear Power and Sustainable Development , IAEA, Vienna , 2016
- [8] LI Chengliang, YANG Mengjia. The Challenge of Nuclear Reactor Structural Materials for Generation IV Nuclear Energy Systems. 20th International Conference on Structural Mechanics in Reactor Technology (SMiRT 20) Espoo, Finland, August 9-14, 2009.
- [9] Igor Pioro and Pavel Kirillov . Generation IV Nuclear Reactors as a Basis for Future Electricity Production in the World.
- [10] GEN International Forum , Annual Report 2021
- [11] Discussion on Goals for Generations IV Nuclear Power Systems. Workshop May 1-3 , 2000 , *Bethesda , Maryland*
- [12] Technology Brief , Nuclear Power , UNECE, Website: <http://www.unece.org>
- [13] UNITED NATIONS, Transforming our World: The 2030 Agenda for Sustainable Development, A/RES/70/1, UN, New York (2015).
- [14] Ümit Ağbulut., Turkey's electricity generation problem and nuclear energy policy. Energy Sources, Part A: Recovery, Utilization , and Environmental Effects. 2019, VOL. 41, NO. 18, 2281–2298
- [15] Guidelines for Application of the United Nations Framework Classification for Resources (UNFC) to Uranium and Thorium Resources. UNECE energy Series No. 55 , (2017)
- [16] World Thorium Occurrences, Deposits and Resources. IAEA TecDoc Series 1877, Vienna (2019)





## PEACEFUL USES OF NUCLEAR ENERGY IN LESS INDUSTRIALIZED COUNTRIES: CHALLENGES, OPPORTUNITIES, AND ACCEPTANCE

Jeffrey Binder,<sup>1</sup> Adam Cohen,<sup>2</sup> Antonio Muller,<sup>3</sup> Ricardo Raineri.\*<sup>4</sup>

September 2, 2022

### Abstract

While less industrialized countries may associate nuclear energy with weapons or with the adverse events that have taken place since the late 1970s, peaceful uses have significantly benefited society, and the opportunity for nuclear energy to play a substantially expanded role in generating clean and abundant electricity is well recognized. For example, in the U.S., where nuclear power accounts for 19% of electricity, even though U.S. public attitudes toward nuclear remain uncertain, a January 2022 Pew Research Center survey found that 35% of U.S. adults say the federal government should encourage the production of nuclear power, 26% say it should discourage it, and 37% say it should neither promote nor prevent it.

In addition to producing clean electricity, the peaceful use of nuclear energy has significantly improved human life in health, agriculture, food preservation, industry, and the understanding of our world and universe. Nuclear technology is used in the diagnosis and treatment of cancer and other diseases, radiography cameras, blood irradiators, and radio sterilization of biological tissues for the treatment of various conditions; it helps the development of scientific knowledge on the understanding and searches for a solution on environmental issues, like climate change and tracing of ecological impacts; in augmenting agricultural productivity and the elimination of food diseases, like reducing the threat of fruit flies in Latin America; and in for various industrial applications like radiography, flow measurement and leak detection in industry and mining, in dredging operations in ports, and space exploration, among many others. Not to mention the critical impact of nuclear energy programs on a solid workforce and the technological development of the countries that scale their capabilities.

For energy, nuclear has the opportunity to expand the supply of clean electricity generation. To achieve the deep decarbonization required to keep the average rise in global temperatures below 1.5°C, combating climate change without an increased role of nuclear power generation would be much more complicated. The IEA state that achieving the pace of CO<sub>2</sub> emissions reductions in line with the Paris Agreement is already a considerable challenge, as shown in the Sustainable Development Scenario. It requires significant increases in efficiency and renewable investment and an increase in nuclear power. Also, the World Nuclear Association notices that nuclear power plants, throughout their life cycle, produce about the same amount of carbon dioxide-equivalent emissions per unit of electricity as wind and one-third of the emissions per unit of electricity compared to solar. Further, with the technological and

\*Corresponding author raineri@ing.puc.cl

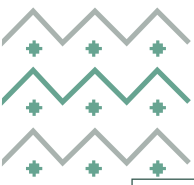
<sup>1</sup> Advisor Associated Universities, Inc. and Boston Government Services, LLC.

<sup>2</sup> President Associated Universities, Inc.

<sup>3</sup> Partner AEM Capital

<sup>4</sup> Professor Pontificia Universidad Católica de Chile, and Advisor Associated Universities, Inc.





financial attributes of small modular reactors (S.M.R.), more countries and regions can gain the advantages of nuclear energy.

In this work, we unveil the opportunities and challenges within less industrialized countries to developing a plan and their capabilities to take advantage of peaceful uses of nuclear energy and power generation.

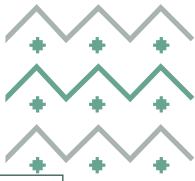
Some of the critical issues/questions we address in this work are:

- How should governments interact with civil society in analyzing and evaluating the peaceful uses of nuclear energy? How should the benefits and risks of peaceful uses of nuclear energy be communicated to civil society? What role has the scientific community here?
- What steps should countries take to build capacities to become ready to decide on building critical infrastructure for the peaceful uses of nuclear energy?
- How can IAEA and other industrialized countries support capacity building in less industrialized countries to be ready for a yes or no decision regarding nuclear energy?
- How important are the institutional framework and strong and independent regulatory and supervisory authorities in the nuclear industry for an atomic program's success and safe development?
- In many countries, institutions are weak, which can seriously threaten the success and safety of any nuclear energy program. How can governments and the international community protect from this risk by exposing the world industry to higher downside risk?
- How should we address the lack of human capital, scientists, and experts in the field?
- Is nuclear power a realistic and cost-effective solution for less industrialized countries, given significant upfront investment costs and construction periods? Is an S.M.R.s turn-on key a solution for less industrialized countries?
- Advantages and disadvantages of installing a turn-key S.M.R. v/s large-scale custom reactor, technology development, and capacity building.
- When building nuclear power infrastructure, upfront investments are significant compared to other power generation sources, such as solar or wind, which can develop. How can less developed countries secure access to finance, and what are its essential requirements?
- What are the critical characteristics of technology when deciding on the alternatives of nuclear technologies available in the market and future S.M.R.s?
- Should nuclear power generation be evaluated as a standalone project, only looking at a long-term reliable supply of cheap energy?
- Chernobyl, Three Mile Island, and Fukushima nuclear accidents marked a stopping point in many countries on their decision to implement a peaceful use of atomic energy program. How can we assure that safety standards, in a broad sense, have been enhanced to preclude future situations like the ones there? Should the safety standards depend on organization structure development and modernized reactor design?

## References

- CCHEN (2020), "Energía Nuclear de Potencia: Revisión de temáticas relevantes para una discusión," Comisión Chilena de Energía Nuclear – CCHEN-
- IAEA (2015), "Milestones in the Development of a National Infrastructure for Nuclear Power," IAEA Nuclear Energy Series No. NG-G-3.1 (Rev. 1).





- IAEA (2021), "Nuclear Technology Review 2021," IAEA GC(65)/INF/2.
- IEA (2022), "Nuclear Power and Secure Energy Transitions: From Today's Challenges to Tomorrow's Clean Energy Systems"
- Nivalde de Castro, Mauricio Moszkowicz and Lucca Zamboni (2022), "Perspectivas da Energia Nuclear no Setor Elétrico Brasileiro," GESEL Grupo de Estudos do Sector Eléctrico, UFRJ.
- Nuclear Energy Institute (2016), "Comments of the Nuclear Energy Institute on Staff's Responsive Proposal for Preserving Zero-Emissions Attributes, Proceeding on Motion of the Commission to Implement a Large-Scale Renewable Program and Clean Energy Standard, Case No. 15-E-0302," State of New York Public Service Commission.
- Pew Research Center (2022), "Americans Largely Favor U.S. Taking Steps to Become Carbon Neutral by 2050", by Alec Tyson, Cary Funk and Brian Kennedy, March 2022.
- Teresa Benson- Wiltschegg (1993), "Applying nuclear techniques for environmental protection: A global research network," IAEA BULLETIN, 2/1993.

## Paper outline:

### **Abstract**

### **Introduction**

### **Chapter 1: The State of N.E. in the World**

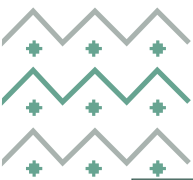
### **Chapter 2: Peaceful uses of Nuclear Energy**

- **Industry**
- **Health**
- **Agriculture**
- **Technology spillover effects**
- **Power generation**
- **Economic benefits**

### **Chapter 3: Challenges of implementing a N.E. program for peaceful uses**

- **Governance and the role of the State in the promotion of a N.E. program for peaceful uses**
- **Technical Capabilities**
- **Social Acceptance and communication to the public**
- **Areas of expertise**
  - **Access to Technology**
  - **Technical capabilities**
- **Human resources requirements**
- **Access to finance**
- **Building key N.E. infrastructure**
  - **Development of local industry**
  - **Regional Development**





- **Engineering, Construction and Operation**

- 

#### **Chapter 4: Conclusions**

#### **References**

### About the Authors:

**Jeffrey Binder** has had over a thirty-year career in applied energy technology as an engineering & scientific contributor and high-impact leader. His experiences include nuclear reactor technology, renewable energy, advanced/critical materials, and manufacturing technology. He has had multiple leadership roles, including Associate Laboratory Director for applied energy at Oak Ridge and Argonne National Laboratories, and the Founding Director of the University of Illinois Applied Research Institute. Dr. Binder has significant international experience in promoting nuclear and renewable energy technology. He has proposed, built, and led multiple technology development initiatives in nuclear reactor safety, fuel cycle, radioisotope production, advanced/critical materials, advanced energy systems, and manufacturing technology. Dr. Binder was a significant leader for the United States in supporting and solving nuclear safety and security issues following the Three Mile Island accident, the dissolution of the Soviet Union and following the Chernobyl accident, and the Fukushima accident in Japan.

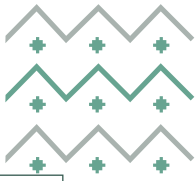
He has a Ph. D. in nuclear engineering from the University of Illinois at Urbana-Champaign and an M.B.A. from the University of Chicago. He is the author or co-author of over 100 publications, articles, and conference submittals.

**Adam Cohen** is the President and C.E.O. of Associated Universities, Inc. (A.U.I.). Before joining A.U.I. in 2017, Dr. Cohen was finishing his term at Princeton University. Until May 2017, he served as the Deputy Under Secretary for Science and Energy at the U.S. Department of Energy (D.O.E.), overseeing basic science, applied energy research, technology development, and deployment efforts, including the stewardship of 13 of the 17 D.O.E. National Laboratories.

His experience includes nearly seven years as Deputy Director for Operations at the Princeton Plasma Physics Lab and 18 years at Argonne National Laboratory, where he held several positions, including Deputy Associate Director for Energy Sciences and Engineering and Deputy Director/Chief Operations Officer. He has served as head of the U.S. Delegation on the ITER Council, on the New Jersey Department of Environmental Protection's Oyster Creek Oversight Panel, and on the D.O.E. Laboratory Operations Board. Earlier in his career, he spent four years in the U.S. Navy as a submarine officer, and he worked at Babcock & Wilcox manufacturing nuclear fuel for research reactors.

Dr. Cohen is a Senior Associate with the Center for Strategic and International Studies Energy and National Security Program.





## ***Nuclear Power Reactors based Hydrogen Production for the Sustainable Development of Smart Cities***

Ashraf Aboshosha

Rad. Eng. Dept., NCRRT, Egyptian Atomic Energy Authority EAEA, Cairo, Egypt

Ashraf.aboshosha@eaea.org.eg

### **Abstract**

Computer modelling and simulation are employed to preferred to reduce the cost and time of feasibility studies for nuclear Hydrogen Production. Several software packages have been used to elaborate the success of the proposed research such as Sketchup, MATLAB, Aspen HYSYS SOLIDWORKS and Labview. This study explores using Nuclear Power Reactor (NPR) to support the hydrogen economy. The Hydrogen is easy to produce, easy to transport, easy to store and easy to use. Hence, this is what makes it a promising approach as energy carrier. This research work presents the production of Hydrogen using nuclear reactors based on Iodine-Sulfur thermolysis techniques. The thermolysis, depends on Very High Temperature reactors (VHTR). Also, this paper introduces the most significant applications of Hydrogen economy. The main purpose is the reduction of carbon dioxide emissions and raising the efficiency of nuclear reactors. Nuclear reactors have their high energy efficiency up to 45%, improved safety relying on passive techniques. Throughout this paper the NPR s will be utilized to generate the hydrogen for the sustainable development of smart cities.







## Decarbonization Policies and Energy Price Reforms in Bangladesh

*Sakib Amin,*

<sup>a</sup> **Presenting Author**, School of Business and Economics, North South University, Dhaka-1229, Bangladesh; Email: [sakib.amin@northsouth.edu](mailto:sakib.amin@northsouth.edu)

*Tooraj Jamasb,*

<sup>b</sup> Copenhagen School of Energy Infrastructure (CSEI), Department of Economics, Copenhagen Business School, Denmark; Email: [tj.eco@cbs.dk](mailto:tj.eco@cbs.dk)

*Manuel Llorca,*

<sup>c</sup> Copenhagen School of Energy Infrastructure (CSEI), Department of Economics, Copenhagen Business School, Denmark; Email: [mll.eco@cbs.dk](mailto:mll.eco@cbs.dk)

*Laura Marsiliani,*

<sup>d</sup> Durham University Business School, and Durham Energy Institute, Mill Hill Lane, Durham DH1 3LB, United Kingdom; Email: [laura.marsiliani@durham.ac.uk](mailto:laura.marsiliani@durham.ac.uk)

*Thomas I Renström,*

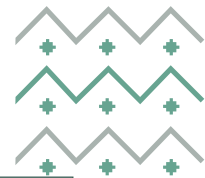
<sup>e</sup> Durham University Business School, Mill Hill Lane, Durham DH1 3LB, United Kingdom; Email: [t.i.renstrom@durham.ac.uk](mailto:t.i.renstrom@durham.ac.uk)

**Abstract.** Bangladesh's electricity sector suffers from heavy subsidization of fossil fuels and regulated electricity prices. These interventions distort the fuel mix in electricity production, promote overconsumption of fossil fuels and slow down the low-carbon transition. As a signatory of the 2015 UNFCCC Paris Agreement, Bangladesh has pledged to reduce GHG emissions by 15% (of which 5% is unconditional) with respect to Business as Usual by 2030, yet its overall CO<sub>2</sub> emissions are increasing. Urgent actions are needed for Bangladesh to fulfil its climate pledge. We use a fit-for-purpose Dynamic Stochastic General Equilibrium (DSGE) model to evaluate the effects of several decarbonization policies, namely the implementation of carbon taxes and the removal of fossil fuel subsidies and intra-sectoral electricity prices distortions. We find that all policies can deliver a win-win situation in terms of macroeconomic variables and CO<sub>2</sub> emissions with respect to a benchmark scenario that includes existing price distortions and no carbon taxes. The reduction of 4.6% in CO<sub>2</sub> emissions achieved in the price reform policy experiment indicates that liberalized energy markets can help achieve its Paris Agreement target. Thus, we recommend that the government considers reforming electricity and fossil fuel price structure to foster economic development and environmental sustainability.

**Keywords:** Carbon Taxes and Fossil Fuel Subsidies; Energy Price Reforms; CO<sub>2</sub> Emissions; DSGE model; Bangladesh.

**JEL Classification:** D58; Q43; Q48; Q51





## ***PRIVATISATION AND ELECTRICITY SECTOR PERFORMANCE: A CASE OF ELECTRICITY DISTRIBUTION COMPANIES IN NIGERIA***

Iyabo A. Olanrele  
Economics and Business Policy Department  
Nigerian Institute of Social and Economic Research  
+2348066226531, [adeyemiyabo@yahoo.com](mailto:adeyemiyabo@yahoo.com)

### **Overview**

The country introduced privatization and competition to stimulate electricity supply efficiency. Consequently, a milestone was achieved in the post-privatization period as electricity generation capacity more than doubled to 12,555 MW. Despite this, electricity supply remains epileptic, in some cases, non-accessible partly due to inherent inefficiencies in the sector. For instance, in 2018, of the total 12,555MW capacity, the average available electricity generated was 3,130.3 MW (World Bank WDI, 2020). Due to the high transmission and distribution losses of about 40 percent (NERC Quarterly Report, 2018), the final electricity consumed was 1,963.3 MW in the same period. Also, Nigeria's electricity consumption per capita is among the lowest years after the privatization reform. Specifically, the per capita electricity consumption of 130 kilowatts per hour (kWh) in 2019 was below the 157kWh recorded in 2012. These statistics question the credibility of the privatization process in enhancing the electricity supply efficiency. Privatization, thus, seems not to have delivered on its aim as supply remained grossly inadequate in meeting demand. A critical question for policy is if privatization reform has enhanced the efficiency of electricity supply in Nigeria. By this, the study seeks to determine the efficiency of electricity supply before and after privatization. Also, the study examines the efficiency of electricity supply across the eleven distribution companies in Nigeria.

### **Methods**

The study adopts the Data Envelopment Analysis (DEA) to analyze the technical efficiency of the electricity supply of the electricity sector as a whole and across the eleven electricity distribution companies. In brief, the DEA is a linear programming technique that analyses all potential output for a given set of inputs (Coelli,1996;); where the outcome assumes a value between zero and one. Several empirical studies in the literature adopted the DEA approach to evaluate firm technical efficiency across different sectors (Jerome, 2008; Chris, 2018). These investigations also include studies on the electricity sector (Adenikinju et al., 2016; Wang et al., 2018). The data point is for 2008 to 2012 (5 years before privatization) and 2015 to 2019 (5 years after privatization). Although the privatization of the electricity sector was in 2013, the effective date for take-over by all successor companies was 1<sup>st</sup> November 2014; hence, 2013 and 2014 are the years of public and private ownership of some generation and distribution companies. The data for the empirical analysis is available in the quarterly reports of the Nigerian Electricity Regulatory Commission Quarterly Reports, National Control Centre, International Energy Agency Energy Report, World Bank World Development Indicators, Department of Petroleum Resources (DPR) Annual Reports, and World Bank Climate Change Knowledge Portal.

### **Results**

The analysis of technical efficiency within the DEA framework shows slight efficiency improvements with privatization, but high network losses inhibit the efficiency gains. In the distribution value-chain, four companies were above 75% efficiency levels, while two operate at less than 50%. As such, privatization has not eradicated technical inefficiencies in Nigeria's electricity supply. The inefficiencies in the electricity sector are partly due to technical and commercial limitations.

### **Conclusions**

The following recommendations are made:

1. Increase infrastructure investment: Although Nigeria's generation and transmission value-chain has improved in total capacity, the low operational capacity and high rate of grid instability entail a need for more infrastructure investment. In 2018, through Nigeria's Presidential Power Initiative (PPI), Siemens entered an Agreement with the Federal Government of Nigeria to expand the electricity network by 25,000MW, the project is yet to be implemented. This and other efforts put forward by the government have not seen the light of the day. Asides, the distribution companies need to increase their revenue



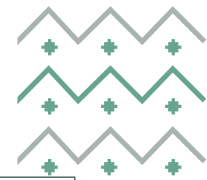
- collection efficiency to enhance the commercial and operational viability of the industry. A good strategy is to increase the metering rate to reduce energy loss and revenue shortfall.
2. Ensure strict compliance with industry standards and regulations. This strategy behooves the Nigerian Electricity Regulation Commission (NERC) to ensure compliance to set down rules and regulations, especially among the distribution companies. The rate of inefficiency in the subsector is high when one considers the gap between the amount of energy received and the Multi-Year Order Tariff (MYTO) allocation. Stringent conditions like fines should be levied on non-compliance.

## References

### References

- Audu, E., Paul, S.O. and Ameh, E. (2017). Privatization of power sector and poverty of power supply in Nigeria: A policy analysis. *International Journal of Development and Sustainability*, Vol. 6 No. 10, pp. 1218-1231.
- Chris A. O (2018). Determinants of the technical efficiency performance of privatized manufacturing firms in Nigeria: an econometric analysis. *International Journal of Development and Economic Sustainability*, Vol.6, No.1, pp. 19-28
- Coelli, T. 1996. A Guide to DEAP Version 2.0. A Data Envelopment Analysis (Computer Program). Centre for Efficiency and Productivity Analysis, Department of Econometrics, University of New England, Australia
- Jerome, A. (2008). Privatization and Enterprise Performance in Nigeria: Case Study of Some Privatized Enterprises. *AERC Research Paper 175* African Economic Research Consortium, Nairobi February 2008
- Nigerian Electricity Regulatory Commission (2018). NERC Quarterly reports. Retrieved from <https://nerc.gov.ng/index.php/library/documents/NERC-Reports/NERC-Quarterly-Reports/>
- Wang, K., Chia-Yen, L., Jieming, Z., and Yi-Ming, W., (2018). Operational performance management of the power industry: a distinguishing analysis between effectiveness and efficiency. *Annals of Operations Research*, Springer, Vol. 268(1), pages 513-537
- World Bank World Development Indicators, 2020. Available on <https://data.worldbank.org/country/NG>





Electricity



## ***ENERGY STORAGE ECONOMICS AND FUTURE MARKET POTENTIAL IN SAUDI ARABIA:***

Khaled S. Alusaimi, Saudi Aramco, +966-13-880-9454, [khaled.alusaimi@aramco.com](mailto:khaled.alusaimi@aramco.com)

### **Overview**

In Carbon constrained world , decarbonization is imperative to reach carbon neutrality targets by many countries between 2050 and 2060 and large adoption of renewable energy is a key measure to decarbonize the electric grid. Saudi Arabia is planning to expand the renewable energy generation to reach 50% of total energy mix by 2030 where the rest planned from natural gas. This target is largely to realize Saudi Arabia’s Nationally Determined Contributions (NDCs) commitments by removing greenhouse gases (GHG) emissions of 278 million tons of carbon dioxide equivalent (CO<sub>2</sub>eq) annually by 2030. According to Saudi National Renewable Program (NREP) recent targets , 58.7 gigawatts (GW) of renewable power capacity is planned by 2030 which constitute of 40 GW of Photovoltaics (PV) power , 16 GW of wind power and 2.7 GW of Concentrated Solar Power (CSP). These future Variable Renewable Energy (VRE) generation by 2030 will help to decarbonize the electric grid however they are intermitted energy sources and cannot be used as base load electricity generation similar to dispatchable power generation sources such as fossil fuels. Therefore, Energy Storage Systems (ESS) is an important enabler to store excess VRE electricity from the grid for later use to further decarbonize the grid to reach carbon neutrality by Saudi Arabia in 2060. Although Saudi National Renewable Program has put targets for future renewable power capacities , there are not enough studies or assessments regarding energy storage future demand in order to have resilient Saudi Arabia grid and to project future potential new ESS electricity market.

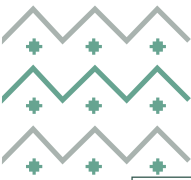
The objectives of this paper are to quantify and evaluate holistically the impact of VRE generation supply in Saudi Arabia’s future electric grid and the potential opportunities of seasonal and long duration energy storage. Moreover, the paper will evaluate the ESS applications and technologies selection to reach optimum system investment costs for ESS deployment in Saudi Arabia and forecasted Levelized Cost of Storage (LCOS). Finally, the paper will shed some lights on recommended policies and regulations to enable Saudi Arabia EES market to be competitive with dispatchable fossil fuel sources and support national net zero carbon objectives by 2060.

### **Methods**

Data collection was completed to quantify future VRE generation from the planned 35 projects locations scattered in Saudi Arabia based on publicly announced power capacity targets by NREP and capacity factors (CF) for each VRE technology type were assessed. In addition, the forecasted power demand and total energy generation from fossil fuels were calculated based on Saudi Electric Company (SEC) announced numbers in 2020 and existing power generation fleet breakdown by sources and technologies were analysed. It was assumed a retirement plan of old gas turbines power generators and there will be base load electricity generation from natural gas and also future low carbon dispatchable from nuclear energy , waste to energy and geothermal resources. An optimization model was formulated to calculate the projected excess electricity from VRE and the ESS potential future market were sized in 2030 and 2040. The model included mixed integer liner algebra programming to quantify future EES applications demand and hence technology selection to provide the optimum EES system cost while meeting NDCs targets. Finally, projected different LCOS technologies type were calculated to understand the competitiveness of EES future market in Saudi Arabia.

Saudi Aramco: Company General Use





### Results

The results shows high seasonality power demand and hence large potential EES market size in GWh in the segments of seasonal energy storage and Long Duration Energy Storage (LDES) to avoid large electricity curtailments. This EES market size is forecasted to increase when VRE reach more than 60% of total power capacity penetration in the grid. In addition, Intra-energy storage applications segment shall be first EES market adaptor to provide daily localized electricity from EES to reduce additional power transmission investment in remote areas from the grid. The optimization model shows Power to X technologies such as hydrogen storage in salt caverns and other LDES technologies such as thermal energy storage and flow batteries will achieve LCOS between 0.082 and 0.045 \$/KWh in 2040 based on future cost learning curves reductions in renewable energy and EES technologies.

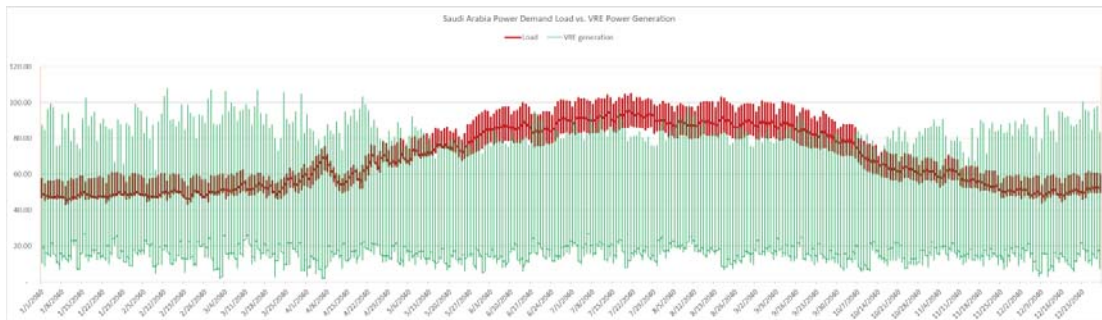


Figure 1. Saudi Arabia Projected Power Demand in 2040 vs. VRE Power Generation Forecast (GW)

### Conclusions

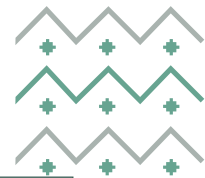
EES deployment in Saudi Arabia is imperative to decarbonize future electric grid and an important bridge to energy transitions and carbon neutrality targets. Although there are economics benefits and technical requirements to expand and create new market for EES, the economics is more favourable to fossil fuels dispatchable power generation resources in the near future and energy policy instruments are needed to incentivize ESS. This is largely due to the lack of carbon pricing, price arbitrage and electricity dynamics pricing opportunity that is required for ESS business models for market entry and growth. Although the reductions of EES capital costs and technology performance improvement will improve the economics of EES market, incentives and market regulations are required from government agencies to promote EES market establishment and growth to meet Saudi Arabia climate targets.

### References

1. Iain Staffell, Stefan Pfenninger, Using bias-corrected reanalysis to simulate current and future wind power output, *Energy*, Volume 114, 2016, Pages 1224-1239, ISSN 0360 5442.
2. Stefan Pfenninger, Iain Staffell, Long-term patterns of European PV output using 30 years of validated hourly reanalysis and satellite data, *Energy*, Volume 114, 2016, Pages 1251-1265.
3. F. Al Harbi and D. Csala, "Saudi Arabia's Electricity: Energy Supply and Demand Future Challenges," *2019 1st Global Power, Energy and Communication Conference (GPECOM)*, 2019, pp. 467-472.
4. Yang Jiao, Daniel Månsson, Greenhouse gas emissions from hybrid energy storage systems in future 100% renewable power systems – A Swedish case based on consequential life cycle assessment, *Journal of Energy Storage*, Volume 57, 2023.
5. Marco Auguadra et al, Planning the deployment of energy storage systems to integrate high shares of renewables: The Spain case study, *Energy*, Volume 264, 2023.







## ***TOWARDS CARBON NEUTRALITY AND ENERGY INDEPENDENCE IN EUROPE: CAN NEW STORAGE AND RENEWABLES PUSH FOSSIL FUELS OUT?***

Milien Dhome, EconomiX, Université Paris Nanterre, France, +33632238974, milien.dhome@parisnanterre.fr  
Marc Baudry, EconomiX, Université Paris Nanterre, France, +33663902165, marc.baudry@parisnanterre.fr

### **Overview**

Variable and renewable energy (VRE) sources lie at the core of the European energy decarbonating and independence strategy. A larger share of renewable generation requires flexibility options to cope with intermittency and production uncertainty. Among the flexibility solutions, energy storage has become increasingly interesting because of its versatility and recent high costs reductions. In this paper, we investigate the development potential of energy storage solutions as future dispatchable assets to compete with existing fossil fuel power plants. Our paper is one of the first to deeply investigate the competition between fossil fuel power plants and storage technologies and present the latter as new incomers that could challenge the incumbents' positions. We propose a novel analysis in the light of the recent energy and geopolitical crisis, which might help the understanding of where Europe stands today in its path towards energy independence. We use a stochastic competitive optimization framework, calibrated on the current Western Europe power system, to derive the market value of new storage technologies and their impact on the price structure. We estimate the long-term equilibrium of flexibility capacities under different renewable horizons, CO<sub>2</sub> prices and vehicle-to-grid (V2G) trajectories. We subsequently analyze incremental revenues and costs due to the presence of storage on the wholesale market and their distributions among renewable firms, conventional power plants and electricity consumers. We find evidence that, without additional support policies, the development of stationary storage remains moderate and located in a few countries of interest. The contribution of V2G is predominant as it accounts for a large part of the new storage capacity. Finally, we highlight a detrimental effect on the revenues of fossil fuel power plants and a significant and positive effect on solar and wind revenues, making the case for a smart design of support public policies that integrates the transfers storage operates between market firms.

### **Methods**

To quantify the energy-only market-based development potential of promising storage technologies and their impact on the price structure, we propose an empirical model representing the current and future Western European electricity power system. We simulate an interconnected version of the European grid until 2040, with 10 of the most important countries for comparison. Our framework relies on stochastic optimization methods to better suit and handle the intermittent nature of renewable-based power systems. On top of providing a probabilistic and frequency analysis, such method renders robust results for the consideration of VRE and storage economic viability, to depict an accurate situation of the near future.

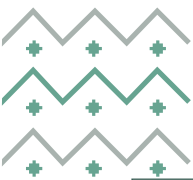
We first construct scenarios by sampling weekly historical data, similarly to a Monte-Carlo approach, which aim at faithfully representing the fundamental discrepancies between seasons and the various states of the power system. Secondly, we derive long-term market equilibria, under efficient hypothesis, by minimizing the total cost of the European power system by allowing investments in new storage and gas capacities. Solving the two-stage problem – capacity expansion and operation - involves a multi-cut algorithm based on Benders decomposition. Our model is calibrated on the Western European power system, with fine modelling of the existing flexibility park, including pumped-hydro storage and nuclear availability. Our work relies on an exhaustive, heterogeneous, and unit-level representation of existing power plants.

### **Results**

We first derive from our methodology estimates of the long-term equilibria of flexibility capacities under different renewable horizons, CO<sub>2</sub> prices, vehicle-to-grid (V2G) trajectories and transition commitments. We find evidence that, without additional policies, the development of stationary storage is moderate and located in a few countries of interest. The effect of CO<sub>2</sub> prices, despite positive consequences on new storage profitability, is still insufficient to significantly increase the market depth. Intermittency stemming from ambitious renewables targets is also largely mitigated by the predominant contribution of V2G, as it accounts for the main share of the new storage capacity. Even in the case of coal or nuclear phase out commitments and subsequent higher flexibility requirements, existing and new gas facilities remain strong competitors to storage investors.







Secondly, we analyze incremental revenues and costs due to the presence of storage on the wholesale market and their distributions among renewable firms, conventional power plants and electricity consumers. We highlight a detrimental effect of storage on the revenues of fossil fuel power plants and a significant and positive effect on solar and wind revenues by supporting low wholesale prices, at the expenses of consumers.

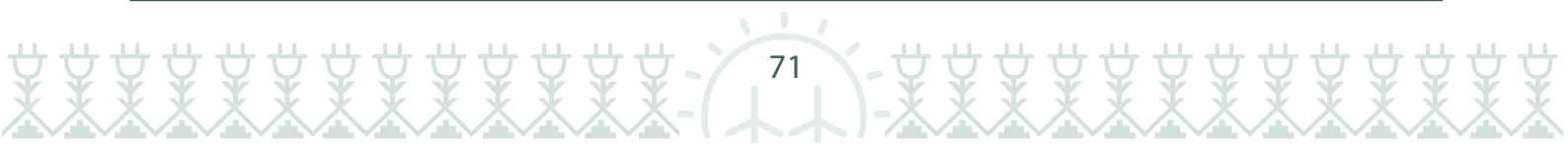
Finally, we characterize to what extent new storage reduces fossil fuel consumption, CO<sub>2</sub> emissions and market volatility. These metrics are of utmost importance to apprehend the possible path towards energy independence and carbon neutrality, as well as the way to reinforce renewable investments. We highlight a non-negligible impact of storage on all the three indicators, which indicates that additional value is to be found in supporting storage development.

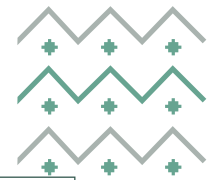
### **Conclusions**

In the recent years, storage has regularly been presented as the last piece to solve the energy transition and independence dilemma by complementing renewable sources. We bring evidence that market-based storage development remains uncertain without additional policies. Reaching the critical market depth for storage will require stronger energy commitments and a concerted reflection of the role of fossil gas in the transition. As the main takeaway, renewable expansion will sooner or later face dropping market revenues, that storage could alleviate but not gas power plants. By supporting low prices and reducing volatility, storage sets up a more sustainable environment for renewable development. Additional value is also to be found in the reduction of fossil fuel consumption and CO<sub>2</sub> emissions. Our study consequently makes the case for an adequate and smart design of support policies that integrates the transfers storage operates between market firms, and the non-market welfare improving services it provides.

### **References**

- Ramteen Sioshansi, (2010), Welfare Impacts of Electricity Storage and the Implications of Ownership Structure, *The Energy Journal*, Volume 31, (Number 2), 173-198
- Ludovic Gaudard and Kaveh Madani, (2019), Energy storage race: Has the monopoly of pumped-storage in Europe come to an end?, *Energy Policy*, Volume 126, 22-29
- Ehsan Nasrolahpour; Jalal Kazempour; Hamidreza Zareipour and William Rosehart, (2016), Strategic Sizing of Energy Storage Facilities in Electricity Markets, *IEEE Transactions on Sustainable Energy*, Volume 7, (Number 4), 1462-1472
- Michael Child; Claudia Kemfert; Dmitrii Bogdanov and Christian Breyer, (2019), Flexible electricity generation, grid exchange and storage for the transition to a 100% renewable energy system in Europe, *Renewable Energy*, Volume 139, 80-101
- Stefan Ambec and Claude Crampes, (2019), Decarbonizing Electricity Generation with Intermittent Sources of Energy, *Journal of the Association of Environmental and Resource Economists*, Volume 6, (Number 6), 1105 - 1134





## Performance of Power Generation in the pre-&-post-COVID-19 Oman: A Dynamic Productivity and Efficiency Analysis

FathollahZadeh Aghdam, Reza, Sultan Qaboos University, +968 2414 2964, rezafa@squ.edu.om  
 Al Kharusi, Sami, Sultan Qaboos University, +968 2414 2849, ksami@squ.edu.om  
 Ahmad, Nisar, +968 2414 2098, nisar@squ.edu.om  
 Al Said, Adham, +968 2414 2907, adham@squ.edu.om  
 Berenjforoush Azar, Bahareh, +61 2 8065 1840, berenjforoush@gmail.com

### Overview

This paper examines the dynamics of productivity and efficiency changes in the generation segment of the Omani Electricity Supply Industry. Special attention is made to capturing COVID-19 impact on such performance measures. We adopted the output-oriented *DEA-like Malmquist Index* approach, which decomposes the variations in total factor productivity into efficiency and technological changes over time. Data for twelve electricity firms are collected from all three regions of Oman's electric power system. These comprise firms listed in Oman's Stock Exchange Market, including more than 60% of the total generation in the Sultanate. Out of four models developed in this study, the predominant results reveal that COVID-19 hurt the industry's overall performance in 2020 but rapidly recovered in 2021. The decomposition of the collective TFP index of the sample firms confirms that the fall in TFP in 2020 is caused by both a fall in average efficiency scores and an inward shift in the estimated best practice frontier. These are likely outcomes of the recessionary impacts of the Pandemic. While average efficiency scores continue to drop, an outward shift in the frontier helps a fast recovery in 2021. Such an outward shift in the frontiers—we content—has its roots in appropriate technological upgrades (at least in some units owned by the sample firms) starting from 2018/2019 onward, far before the Pandemic. *Al Kamal, Sembcorp Salalah, SMN Power*, and *Musandam Power* have consistently been on the year-to-year best practice frontiers. *Sembcorp Salalah* and *Musandam Power* continually show the most remarkable performances over time, demonstrating a technological breakthrough while being on the best practice frontiers.

### Methods

In this study, we adopt the *DEA-like Malmquist Index* approach that is justifiable to analyse the dynamics of efficiency and TFP changes in Oman's power-generating firms. The *DEA-like Malmquist Index* is well elaborated in Coelli *et al.* (2005, pp. 289-310). More precisely, the (output-oriented) *Malmquist index*, using the concept of *Distance Function* (Coelli *et al.* 2005, pp. 47-51), is modelled as follows:

$$m_o(y_{t-1}, x_{t-1}; y_t, x_t) = \frac{d_o^t(y_t, x_t)}{d_o^{t-1}(y_{t-1}, x_{t-1})} \times \left[ \frac{d_o^{t-1}(y_t, x_t)}{d_o^t(y_t, x_t)} \times \frac{d_o^{t-1}(y_{t-1}, x_{t-1})}{d_o^t(y_{t-1}, x_{t-1})} \right]^{1/2} \quad (\text{Equation 1})$$

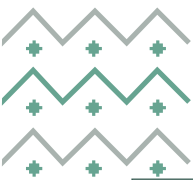
Where  $x$  is the vector of inputs;  $y$  is the vector of outputs;  $m_o$  represents TFP change. As can be seen, there are several distance functions in this formula, described by  $d_o(\cdot)$ . For instance,  $d_o^{t-1}(y_t, x_t)$  represents the distance of a typical DMU at year  $t$  from the frontier at year  $t-1$ . A value of  $m_o$  greater than one indicates positive TFP growth from year  $t-1$  to year  $t$ , while a value of  $m_o$  less than one indicates negative TFP growth. The ratio outside the square brackets in Equation (1) measures the relative efficiency change between years  $t$  and  $t-1$ —relative proximity to the frontier. The remaining part of Equation (1) measures technological change—shifts in the frontier.

In the *DEA-like Malmquist Index*, four Linear Programming (LP) models must be solved to calculate the components of equation 1. Thus, for the  $i^{\text{th}}$  DMU, four distance functions (i.e.,  $d_o(\cdot)$ s) must be estimated between two consecutive periods,  $t-1$  and  $t$ :

$$\begin{aligned} [d_o^t(y_t, x_t)]^{-1} &= \max_{\phi, \lambda} \Phi \\ \text{st} \quad & -\Phi y_{it} + Y_t \lambda \geq 0 \\ & x_{it} - X_t \lambda \geq 0 \\ & \lambda \geq 0 \end{aligned} \quad (\text{Equation 2})$$

$$\begin{aligned} [d_o^{t-1}(y_{t-1}, x_{t-1})]^{-1} &= \max_{\phi, \lambda} \Phi \\ \text{st} \quad & -\Phi y_{i,t-1} + Y_{t-1} \lambda \geq 0 \\ & x_{i,t-1} - X_{t-1} \lambda \geq 0 \\ & \lambda \geq 0 \end{aligned} \quad (\text{Equation 3})$$





$$[d_o^t(y_{t-1}, x_{t-1})]^{-1} = \max_{\Phi, \lambda} \Phi$$

$$st \quad -\Phi y_{it-1} + Y_t \lambda \geq 0$$

$$x_{it-1} - X_t \lambda \geq 0$$

$$\lambda \geq 0 \quad \text{(Equation 4)}$$

$$[d_o^{t-1}(y_t, x_t)]^{-1} = \max_{\Phi, \lambda} \Phi$$

$$st \quad -\Phi y_{it} + Y_{t-1} \lambda \geq 0$$

$$x_{it} - X_{t-1} \lambda \geq 0$$

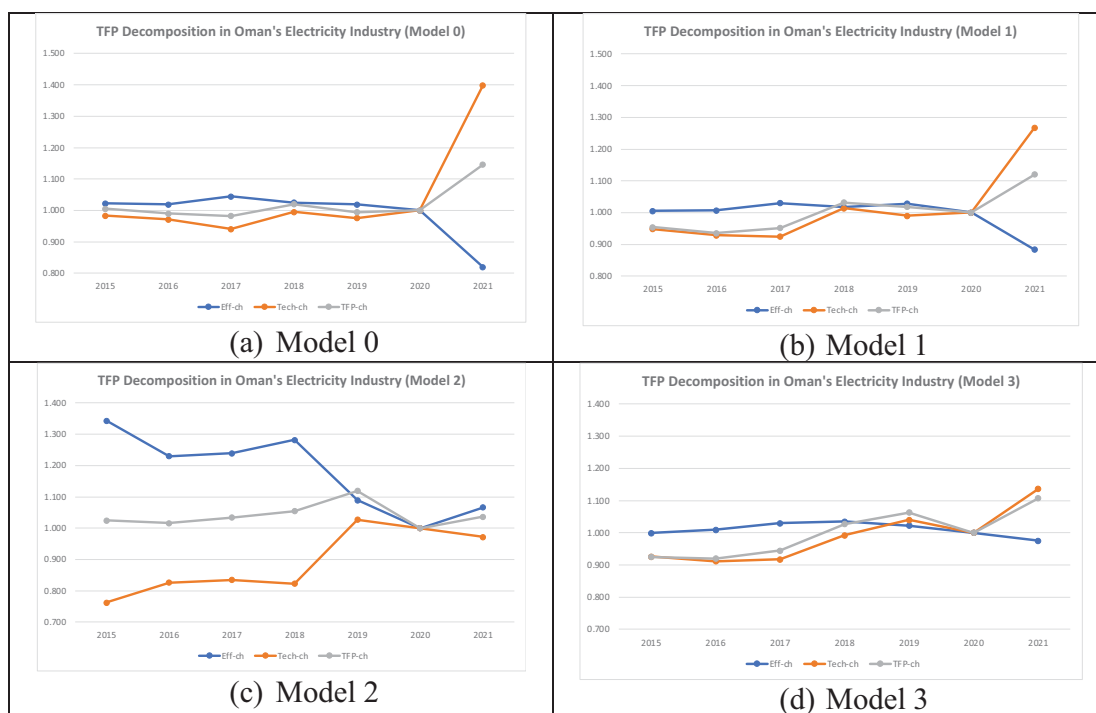
$$\lambda \geq 0 \quad \text{(Equation 5)}$$

Where notations are defined as follows:

$y_{it}$  is a  $M \times 1$  vector of output quantities for the  $i^{\text{th}}$  DMU in the  $t^{\text{th}}$  period  
 $x_{it}$  is a  $K \times 1$  vector of input quantities for the  $i^{\text{th}}$  DMU in the  $t^{\text{th}}$  period  
 $Y_t$  is a  $N \times M$  matrix of output quantities for all  $N$  DMUs in the  $t^{\text{th}}$  period  
 $X_t$  is a  $N \times K$  matrix of input quantities for all  $N$  DMU in the  $t^{\text{th}}$  period  
 $\lambda$  is a  $N \times 1$  vector of weights; and  
 $\Phi$  is a scalar.

## Results

The most revealing results are visualised in the following figures.



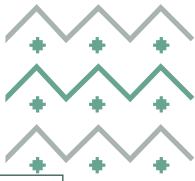
## Conclusions

This paper set out to determine the dynamics of productivity and efficiency changes in the generation segment of the Omani Electricity Supply Industry. A predominant observation from the results of the four models developed for this purpose is that the collective TFP index (the geometric average) had an increasing trend from 2015 to 2019. Then, there is a TFP decline in 2020, followed by a significant recovery in 2021, irrespective of the magnitudes. This observation strengthens the conclusion that *COVID-19 hurt the industry's overall performance in 2020 but rapidly recovered in 2021*. The decomposition of the collective TFP index of all firms confirms that the fall in TFP is caused by both a fall in average efficiency scores and an inward shift in the estimated best practice frontier in 2020. These are likely outcomes of the recessionary impacts of the Pandemic. Nonetheless, while average efficiency scores continue to drop, an outward shift in the frontier helps a fast recovery in 2021. We contend that such an outward shift in the frontiers has its roots in timely technological upgrades (at least in specific units owned by the sample firms), starting from 2018 onward.

## References

Coelli, T. J., Rao, D. S. P., O'Donnell, C. J., & Battese, G. E. (2005). *An introduction to efficiency and productivity analysis*: Springer science & business media.





## ***TRACKING INNOVATION NETWORKS IN ELECTRICITY USING TWITTER***

Rolando Fuentes, Tec de Monterrey and KAPSARC, +523318817264, [rolando.fuentes@tec.mx](mailto:rolando.fuentes@tec.mx)

Frank. Felder, KAPSARC, [frank.felder@kapsarc.org](mailto:frank.felder@kapsarc.org)

### **Overview**

In this paper, we make an approximation of the innovation network in the electricity sector worldwide. The structure of the network matters to determine the cumulative body of knowledge and the virality of new ideas. Understanding the shape of this network can help explain, for instance, the patterns of diffusion of technological innovation such as the direction, speed, growth and accuracy of future innovations, i.e. the degree of network effect, (Katz et al. 1994, p. 94).

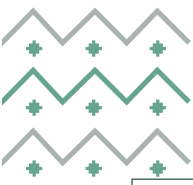
The second objective is to identify influential players within this network. Our premises are as follows: each participant has a piece of information necessary for the solution of specific problems. The problem can only be solved when all information is pooled. Individuals interact and influence one another, but they do so more with those participants with whom they have proximity. While each member of the network can communicate directly with those with whom they are directly linked, they can reach out many more depending on their level of connectivity. The more these nodes are positioned at the core of the network, the more likely they will influence innovation, or be early adopters. Centrality gives participants a technological edge, and a perception of leadership and influence. Other important players are "gatekeepers". These are nodes that while not necessarily central, are the single entry point connecting a cluster with the rest of the network. They could influence the group by withholding information or distorting its transmission.

### **Methods**

In the past, it would have been very difficult to draw a map like this. However, participants now leave digital traces of their relationships. We approximate the network of innovation in the electricity sector, which includes venture capitalist, government agencies, university professors, and firms. The seed of this network is a dataset of electricity startups database that we developed and describe in Fuentes, et.al. (2022). This dataset includes these startups' Twitter accounts. We snowball this original dataset by recording who these startups follow, and classify them according to their main activity as venture capitalists, government agencies, university professors, etc. The underlying assumption of this database is that if two participants know X, it is more likely that they know each other.

One way to identify leaders in communities is to question positional (formal) leaders to develop a list of reputed (informal) leaders; then ask these reported reputed leaders to determine their top influential. We instrument this idea using Twitter. We identify those accounts from our dataset with the highest number of shared connections, strong ties (participants who follow each other) and weak ties (accounts whose following is not reciprocated).





## Results

Our results will visually show patterns of social network and we will analyse their consequences.

- The first result is the identification of central players (leaders) in the entire network, by region and by category.
- Then we assess the overall structure of the network: average distance between participants, webiness, and clusters.
- We then categorize networks and subnetworks as closed or open, depending on the existence of weak, strong or absent ties. This is important because a closed networks can collude, while more open networks can promote innovation as new ideas reach the cluster thanks to strength of weak ties.
- Then since the aim of this exercise is to understand ahead of time which ideas will become more viral we analyse what are the key interests of key network participants. We match their "revealed" interests in Twitter with 4 megatrends --decarbonization, digitalization, distributed technologies or electrification-- and the 43 key technology domains that we identified earlier in Fuentes et.al. (2022).

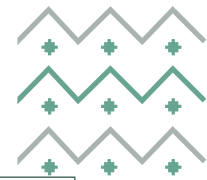
## Conclusions

There are many caveats with this approach. First, this is an informal network and "friendships" in social networks are not really comparable to friendships in real life. We therefore may be overestimating the size of the network and how solid these relationships are. However, Twitter is a channel for information flow. Another is that networks are loose structures that are created spontaneously, and whose outcomes would be difficult to direct.

## References

- Freeman, L. C. (1977). A set of measures of centrality based on betweenness. *Sociometry*, 35-41.
- Freeman, L. C. (1978). Centrality in social networks conceptual clarification. *Social networks*, 1(3), 215-239.
- Oh, D. S., Phillips, F., Park, S., & Lee, E. (2016). Innovation ecosystems: A critical examination. *Technovation*, 54, 1-6.
- Backstrom, L., Boldi, P., Rosa, M., Ugander, J., & Vigna, S. (2012, June). Four degrees of separation. In *Proceedings of the 4th Annual ACM Web Science Conference* (pp. 33-42).
- Freeman, L. C., Fararo, T. J., Bloomberg Jr, W., & Sunshine, M. H. (1963). Locating leaders in local communities: A comparison of some alternative approaches. *American Sociological Review*, 791-798.
- Granovetter, M. S. (1973). The strength of weak ties. *American journal of sociology*, 78(6), 1360-1380.
- Freeman, L. (2004). The development of social network analysis. *A Study in the Sociology of Science*, 1(687), 159-167.
- Edunov, S., Diuk, C., Filiz, I. O., Bhagat, S., & Burke, M. (2016). Three and a half degrees of separation. *Research at Facebook*, 694.
- Ferguson, N. (2017). *The square and the tower: networks, hierarchies and the struggle for global power*. penguin uk.
- Katz, M. L., & Shapiro, C. (1985). Network externalities, competition, and compatibility. *The American economic review*, 75(3), 424-440.





## OVERCOMING WEATHER DATA SCARCITY TO AID POLICYMAKERS IN EFFECTIVE RENEWABLES DEPLOYMENT FOR SAUDI ARABIA

Marie Petitet, KAPSARC, +966 11 290 3462, [marie.petitet@kapsarc.org](mailto:marie.petitet@kapsarc.org)  
 Amro M. Elshurafa, KAPSARC, +966 11 290 3027, [amro.elshurafa@kapsarc.org](mailto:amro.elshurafa@kapsarc.org)  
 Frank A. Felder, KAPSARC, +966 11 290 3000, [frank.felder@kapsarc.org](mailto:frank.felder@kapsarc.org)

### Overview

In many countries, the power generation sector is undergoing a transformation through the deployment of renewable energy (RE) to address climate change issues. Given that weather data is crucial for effective RE deployment, we observe that several countries have already started collecting this data specifically tailored for RE deployment purposes. In many cases, however, such as the Middle East and North Africa region, not enough historic data has been compiled yet. Despite the inadequate data available, many countries have already started planning their energy future RE targets, and others have actually started executing these plans.

In light of the above, we investigate herein the extent to which long-term plans, stemming from capacity expansion models, are impacted by weather-dependent RE assumptions. Explicitly, the assumptions assessed are the firm capacity (FC) and forced outage rate (FOR) of renewables. The analysis was conducted in the context of Saudi Arabia, where a 50% renewable energy target is set to be met by 2030 ("[Renewable Energy Sector in the Kingdom](#)" 2022). Beyond the modeling efforts, we quantify the sensitivity of long-term plans to FC and FOR assumptions. In our Saudi Arabian case study, values assumed for FC and FOR resulted in a 10% variation in power system costs, and 14% and 26% variations in RE and storage deployment respectively.

### Methods

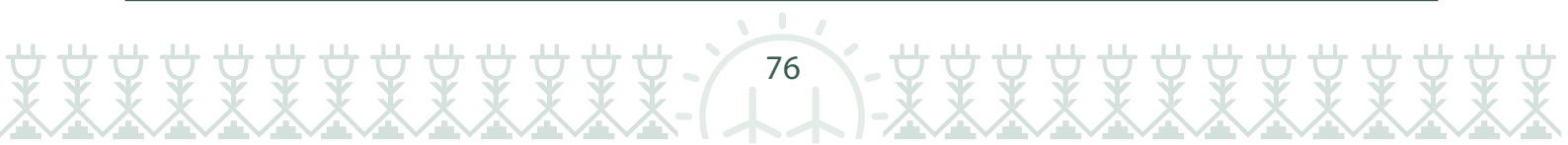
First, we review available RE-specific weather data for Saudi Arabia and highlight that very few data sets are available. When available, these data sets are single-year data sets. The FC and FOR are the two parameters describing RE that would be influenced most by lack of weather data. The firm capacity is defined as capacity that is guaranteed to be available when required, and thus available to meet the resource adequacy requirement, whereas forced outage rate refers to the percentage of time when the power plant is not able to generate electricity, due to mechanical failures or weather conditions. To overcome the lack of data available for Saudi Arabia, we deduce a range for the FC and FOR particularly for solar photovoltaics (PV) and wind technologies based on a literature review for several countries. We arrive at the two following sets of assumptions regarding RE:

- An optimistic case where the FC is 30% for solar PV and 25% for wind, and the FOR is 10% for solar PV and 50% for wind.
- A pessimistic case where the FC is 10% for solar PV and 5% for wind, and the FOR is 30% for PV and 80% for wind.

The FC is used for long-term planning purposes, i.e., to arrive at installed capacities that would meet a reserve margin target. On the other hand, the FOR is used for dispatch purposes to assess resource adequacy in 2030 through the loss of load probability metric. We combine these two sets of assumptions with two 2030 RE energy targets. Thus, we consider four scenarios that differ by varying two main assumptions: being optimistic or pessimistic regarding RE in terms of FC and FOR, and the share of RE in total consumption by 2030. Table 1 names and summarizes the considered scenarios.

**Table 1:** Summary of scenarios simulated

Scenario Name	Share of RE by 2030	RE assumptions
25-Opt	25%	Optimistic
25-Pes	25%	Pessimistic
50-Opt	50%	Optimistic
50-Pes	50%	Pessimistic







Second, we run a long-term capacity expansion plan of the four scenarios for Saudi Arabia over the 2018-2030 horizon. The simulations were conducted using the KAPSARC Power Model ([Elshurafa et al. 2021](#); [Elshurafa and Peerbocus 2020](#); [Soummane et al. 2022](#)), which was built using the commercially available software PLEXOS. The model describes six Saudi regions along with the existing transmission interconnections between them and solves the problem via mixed-integer linear programming.

Third, we analyze the different simulated scenarios in terms of capacity expansion, system costs, and resource adequacy level. We also assess the additional cost that would be borne by considering a long-term plan with a set of assumptions that turns out to be inaccurate with respect to RE weather data, i.e., the additional cost born in case of policymaking based on inaccurate RE assumptions.

## Results

First, our results highlight that long-term plan significantly varies depending on RE assumptions. Indeed, by 2030, RE and storage installed capacities increase by up to 14% and 26% respectively in Pes-RE scenarios with respect to Opt-RE ones. This turns to an increase in power sector cost by up to 10% in Pes-RE scenarios over the period 2018-2030. However, as more RE and storage are developed in Pes-RE scenarios, carbon emissions observed in 2030 are slightly decreased (0.1-2.9%) compared to the Opt-RE counterparts.

Second, solar PV is a more economical choice than wind power in Saudi Arabia given our cost assumptions. In 2030, the 50% RE target is achieved by installing 140-160GW of solar PV and only 2GW of wind. Given that this large amount of solar PV would be challenging to be installed in a few years, we rerun the simulations with a cap on the new annual solar PV and wind builds, but still reached the 2030 renewable target, which result in a share of wind and solar capacities of roughly 50%-50%.

Third, storage and transmission network developments play a significant role in our long-term plans to help in managing RE intermittency and variability. When considering different RE assumptions for their FC and FOR, the balance between storage and transmission development varies, with a trend to develop more storage and less transmission in Pes-RE with respect to Opt-RE.

## Conclusions

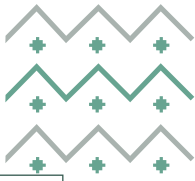
RE development will challenge the resource adequacy of power systems worldwide. In the Middle East and North Africa, the first RE projects have been developed but few RE-specific weather data sets that span several years are available, if any. This paper quantified the extent to which FC and FOR would impact the modeling results of a capacity expansion modeling exercise within the context of Saudi Arabia.

Variations observed in the results are significant, with up to 10% in additional system costs and 26% in additional storage capacity when considering pessimistic FC and FOR assumptions with respect to optimistic ones. These findings support the significance of country- and technology-specific data collection tailored to RE to minimize, to the extent possible, additional (but avoidable) costs that would be born during the transition to the sought future.

## References

- Elshurafa, Amro M, Hatem Alatawi, Salaheddine Soummane, and Frank A Felder. 2021. "Assessing effects of renewable deployment on emissions in the Saudi power sector until 2040 using integer optimization." *The Electricity Journal* 34 (6): 106973.
- Elshurafa, Amro M, and Nawaz Peerbocus. 2020. "Electric vehicle deployment and carbon emissions in Saudi Arabia: a power system perspective." *The Electricity Journal* 33 (6): 106774.
- "Renewable Energy Sector in the Kingdom." 2022. Saudi Vision 2030. <https://www.vision2030.gov.sa/thekingdom/explore/energy/>.
- Soummane, Salaheddine, Amro Elshurafa, Hatem Al Atawi, and Frank Felder. 2022. Cross-seasonal Fuel Savings from Load Shifting in the Saudi Industrial Sector. Discussion Paper. KAPSARC.





## **[DECARBONIZING THE GERMAN POWER SECTOR – A CASE STUDY ON THE INTEGRATION OF POWER-TO-HYDROGEN AND H<sub>2</sub>-IMPORTS]**

[Marco Sebastian Breder, University of Duisburg-Essen, +49 201 1836459, marco.breder@uni-due.de]

[Julian Radek, University of Duisburg-Essen, +49 201 1833399, julian.radek@uni-due.de]

[Christoph Weber, University of Duisburg-Essen, +49 201 1832966, christoph.weber@uni-due.de]

### **Overview**

The ambitious decarbonization goals call for a quick transformation of the energy system. Focusing on the power sector, only rapid and targeted efforts might now be helpful to meet the goals on international and national level. So far, the expansion of renewables like wind and solar energy plays a major role in the German power sector. Despite the commitment to phase out coal, coal and gas in particular continue to contribute significantly to electricity supply. In order to decarbonize this sector as soon as possible and to foster sustainable concepts such as sector coupling, green hydrogen (H<sub>2</sub>) is seen as an important part in the German power sector transformation. Until now, domestic production as well as imports usually served only specific processes on industrial scale. Due to increasing generation from fluctuating renewables as well as the possibility of converting industrial processes and mobility applications to use green H<sub>2</sub> instead of other resources, the integration and scale-up of a hydrogen industry is crucial for energy transition. Several questions arise like to what extent does a power-to-hydrogen industry need to be developed to provide, among other things, sufficient flexibility in the power system. Another important question is the role of hydrogen-fired plants as substitutes for coal-fired and gas-fired plants. Considering this and possible increasing demand from industry and mobility sectors make it necessary to further analyse the role of H<sub>2</sub>-imports. In this context, we analyse in stylized case studies possible decarbonization paths under several assumptions on H<sub>2</sub> with the goal of a complete decarbonization by 2050 at latest.

### **Methods**

We start with a literature review on comparative analysis regarding power sector decarbonisation and the integration of power-to-hydrogen or H<sub>2</sub>-Imports. From these findings, we create various scenarios which will be applied in an optimization model. This model is a planning tool for the long-term development of the European electricity and heat market and allows in particular the endogenous determination of the expansion of conventional and renewable plant capacities as well as flexibilities like battery storages and power-to-gas capacities. It is based on minimizing system costs and thus corresponds to the market result under full competition. Existing capacities generate at least their variable costs and fixed operating costs. Endogenously added capacities generate at least their full costs. A particular strength of the model is the stochastic representation of the renewable feed-in by means of recombining trees. Uncertainties regarding different renewable feed-ins are therefore taken into account. To keep the problem solvable in a reasonable amount of time, a 'typical day' method is applied. Political interventions can be taken into account with further restrictions. The model calculates, among other things, the optimal power plant portfolio, electricity prices, power plant operations, trade balances and the CO<sub>2</sub> price or CO<sub>2</sub> emissions. Applications of the model can be found in Swider and Weber (2007), Spiecker et al. (2013), Spiecker and Weber (2014), Bucksteeg et al. (2019) and Blumberg et al. (2022).

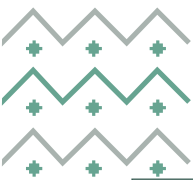
### **Results**

Preliminary results will be provided at the conference.

### **Conclusions**

Conclusions will be provided at the conference.





## References

Blumberg, Gerald; Broll, Roland; Weber, Christoph (2022): The impact of electric vehicles on the future European electricity system – A scenario analysis. In: Energy Policy 161, p. 112751. DOI: 10.1016/j.enpol.2021.112751.

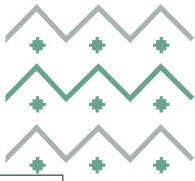
Bucksteeg, Michael; Spiecker, Stephan; Weber, Christoph (2019): Impact of Coordinated Capacity Mechanisms on the European Power Market. In: EJ 40 (2). DOI: 10.5547/01956574.40.2.mbuc.

Swider, Derk J.; Weber, Christoph (2007): The costs of wind's intermittency in Germany: application of a stochastic electricity market model. In: Euro. Trans. Electr. Power 17 (2), p. 151–172. DOI: 10.1002/etep.125.

Spiecker, Stephan; Vogel, Philip; Weber, Christoph (2013): Evaluating interconnector investments in the north European electricity system considering fluctuating wind power penetration. In: Energy Economics 37 (3), p. 114–127. DOI: 10.1016/j.eneco.2013.01.012.

Spiecker, Stephan; Weber, Christoph (2014): The future of the European electricity system and the impact of fluctuating renewable energy – A scenario analysis. In: Energy Policy 65 (1), p. 185–197. DOI: 10.1016/j.enpol.2013.10.032.





## ***IMPACT OF E-MOBILITY ON DISTRIBUTION SYSTEMS: THE ROLE OF SMART TARIFFS FOR VEHICLE GRID INTEGRATION***

MARCO CABANO, CESI S.p.A. – Milan (ITALY) – email: marco.cabano@cesi.it  
BRUNO COVA, CESI S.p.A. – Milan (ITALY) – email: bruno.cova@cesi.it  
DAVID DRESCO, CESI S.p.A. – Milan (ITALY) – email: david.dresco@cesi.it  
LUCA MIGLIORINI, CESI S.p.A. – Milan (ITALY) – email: luca.migliorini@cesi.it  
PIERLUIGI VICINI, CESI FZE – Dubai (UAE) – email: pierluigi.vicini@cesi.it

### **Overview**

Advanced economies and emerging countries are developing net-zero emissions roadmaps to reach carbon neutrality in the mid of this century. They are supported by several international agencies and organizations, which are building different scenarios to reach globally this goal, with all the underlying challenges. In recent times, with the energy crisis triggered by the conflict in Eastern Europe, it appears evident that decarbonization of our economies is also beneficial for energy security, with renewable sources that can be freely leveraged to produce energy decreasing the dependency on fossil fuels (often concentrated in few areas). In last years the electricity sector has been a forerunner in the decarbonization through RES, especially in EU where the CO<sub>2</sub> emissions in this segment decreased by almost 50% in comparison with 1990. However, other sectors lag behind in the decarbonization path, such as transportation: indeed, in the EU transport was the only sector to register an increase of CO<sub>2</sub> emissions (+25%) in 2019 with respect to 1990. Therefore, significant efforts shall be focused on this segment, where according to IEA emissions shall decrease from 2020 levels by 20% in 2030 to be on track to reach carbon neutrality in 2050. One of the most relevant solutions for the decarbonization of transport sector is represented by e-mobility, which can leverage on higher efficiencies compared to internal combustion engines and on the widespread diffusion of renewable power plants that can supply cleaner electricity to the vehicles. The diffusion of alternative vehicles will also be supported by normative initiatives, such as the EU proposal to ban the sale of new fossil fuel cars from 2035, which has been endorsed by the European Parliament.

The transformation of the transport sector, which will be to a larger extent covered through electrification, will have a non-negligible impact on the power system and their infrastructure: alongside the electrification of end-uses which will increase the power consumption in the next decades, a relevant amount of electricity shall be supplied to vehicles, leading to needs for replacement and upgrade of power infrastructure. With regard to e-mobility the major challenges are related to the power component, due to the possibility of having multiple charging events concentrated close to the current power peaks (e.g. in the evening), leading to the substitution of power components such as transformers, feeders and cables. The possibility to leverage on smart charging mechanisms, and in the first place to smart tariff schemes aiming to flatten the demand profile could deliver significant benefits in a systemic perspective.

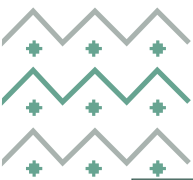
### **Methods**

CESI developed a methodology and a specific tool to estimate the additional investments needed in a distribution system due to the presence of electric vehicles, and the related savings that can be obtained in case of an improved tariff scheme. In the specific case, the comparison has been done between a flat tariff (a unique price for the entire day) and a Time of Use tariff (enabling to have a lower price during the night, period characterized by a lower electricity demand).

The analysis has been divided in two main tasks: (i) Assessment of the demand of electric vehicles, (ii) Quantification of investments in the distribution grid.

For the first task, CESI developed a proper tool to estimate the demand of e-mobility in a certain area, which consider a series of factors, including:

- Type of vehicles (e.g. passenger cars, light duty vehicles, heavy duty vehicles, bus, etc.).
- Charging points, with differentiation based on nominal power and technology (e.g. unmanaged charging, V1G or V2G).
- Charging behavior (i.e. timing and duration of charging events).
- Charging location, considering habits of different types of users.
- Use of the vehicle (i.e. travelled distance).
- Share of electrification, with the possibility to assess different scenarios of e-mobility penetration.



The type of tariff implemented is also considered in the tool, with the flat tariff that does not affect the time of the day a user will recharge its vehicle, while the ToU tariff incentivizes the driver to recharge the EV when the price is lower. Considering those factors, it is possible to calculate the demand profile associated to EVs with an hourly discretization.

In the second task, according to the information available on the distribution components, a proper classification of the different assets with respect to their load factor (i.e., the ratio between the maximum power and the nominal power) shall be carried out. This activity could be done by splitting the components in classes according to their load factors (e.g., 10% of the transformers present a load factor of 0.9, 20% have a load factor of 0.8, etc.). Subsequently, the conventional load (i.e., the electricity demand excluding e-mobility) is calculated considering the rate of load growth foreseen for the year in the targeted scenario. Through a proper distribution of the electricity demand on the different underlying distribution assets is possible to calculate the new load factors associated to the increase of the conventional load. After setting a proper threshold for the load factor above which the component shall be substituted, it is possible to calculate the investments needed related to the increase of the conventional load. This calculation shall rely upon a solid base of costs related to the specific components and to the area object of the study. Finally, adding the contribution of e-mobility to the electricity demand is possible to identify the eventual new peak power and repeat the previous steps for calculating the new investments needed. In this way it will be possible to clearly identify and quantify the additional investments needed in the distribution grid exclusively caused by e-mobility and compare the cases between flat and smart tariff.

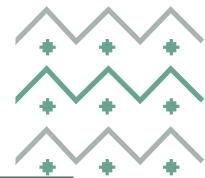
### **Results**

According to the analysis made, which are dependent on the context in terms of load profile and future growth, uptake of electric vehicles and ageing of distribution components, the introduction of a ToU tariff could lead to savings in investments even greater than 50%. However, the possibility to defer grid investments to this extent depends also on the willingness of the users to adopt the tariff scheme and the availability of technologies that could enable a proper programming of the charging events. On the other side, ToU tariffs could represent the first and easiest step for the integration of EVs in the network, suggesting the presence of a relevant potential for investment savings through more complex smart charging technologies (e.g. V1G, V2G) and the possibility to proactively use EVs as a useful resource for the power system.

### **Conclusions**

After a brief recall of the decarbonisation objectives set by the EU with special focus on transport sector, the paper will provide an overview of the tariffs schemes adopted in some key countries highlighting pros and cons for e-mobility, considering the specific environment of Saudi Arabia. Thereafter, the methodology adopted to minimize the investment effort in distribution grids leveraging on tariff schemes will be described in detail. Finally, the possible benefits to the Kingdom arising from appropriate tariff schemes in terms of peak demand reduction will be discussed.





## The economic and financial impact of reforms to the electricity supply industry in Saudi Arabia

Jeremy Rothfield, Senior Fellow, KAPSARC, Tel: +966 532533718. Email: Jeremy.Rothfield@kapsarc.org

### Overview

Reforms to the Saudi electricity industry have been taking place progressively since the late 2000s. The stated objective of the reforms has been to enhance the efficiency and sustainability of the electricity sector, commensurate with the goals set out in Vision 2030. A key element of the reforms has been a bolstering of the functions of the independent regulatory agency, which is currently the Water and Electricity Regulatory Authority (WERA). WERA has been charged with the responsibility for introducing a new revenue model which will be used to determine the prices that are levied by the incumbent monopoly electricity business, the Saudi Electricity Company (SEC). WERA is obliged to ensure that the revenues earned by the SEC are just sufficient to cover the company's efficient costs of providing services to customers. The company must also be permitted to earn a fair return on invested capital (SPA, 16 November 2020).

A regulatory asset base methodology has been developed for the SEC to enable tariff setting for transmission services, distribution services, and electricity generation (Fitch, Rating Action Commentary). A pass-through mechanism is also in place to allow for cost over-runs caused by unanticipated changes to fuel prices, licence and interconnection fees, and taxes.

In future years, the Ministry of Energy will assess the difference between the required revenue for SEC, as determined by the regulator, and the company's actual earnings, from the tariffs that have been established. To the extent that there are unexplained shortfalls, then these will be financed from a balancing account held by the Saudi government (SEC, 29 March 2021). The SEC must nonetheless commit to raising the standard of service provided to customers.

Further reforms to the electricity supply industry in Saudi Arabia remain under consideration. Previous research (Hasan S., T. Al-Aqeel, and N. Peerbocus) has pointed to the types of structural reform and institutional change that have been made in overseas jurisdictions. Typically, the industry is disaggregated vertically and horizontally so that electricity retailing, distribution, transmission and generation become separate and discrete activities. There may also be an unbundling of generation assets, accompanied by the creation of separate, competing business units. Concurrently, a wholesale market needs to be developed, with some functions devolved to a system operator.

### Partial withdrawal of government subsidies for primary energy (fuels) and electricity

The government of Saudi Arabia has taken steps to lower the subsidies that are provided for domestic hydrocarbon-based fuels. Thus, the prices for a range of fuels sold in the domestic market were increased in late 2015, and were then subject to further increases in 2018. Simultaneously, the government chose to bring down the subsidies that are available for electricity prices paid by different classes of customers.

For electricity sold to residential customers, average prices rose from SAR 0.0814 per kilowatt hour (kWh) in 2015, to SAR 0.0915 in 2016, and then to just under SAR 0.2 per kWh by 2018.

The analysis undertaken for this paper is focussed on market structures and regulatory arrangements, and thus does not give consideration to the likely impact of further changes to the prices of fuels used for electricity generation.

Instead, the emphasis is on how a greater degree of scrutiny by WERA might bring about a heightened level of transparency by the SEC. It is expected that WERA will review the capital and operating expenditure plans of the business, and remit them back to the SEC for further consideration. WERA will also evaluate a host of other metrics, including the rate of return on capital, and will be responsible for determining the average prices paid by customers, having regard to both the viability of the industry and the long-term interests of consumers.

### Comparisons with overseas experience

International experience has shown that the corporatisation and restructuring of the electricity sector has the potential to deliver substantial benefits to consumers and to economic activity more generally. Consumers benefit from a wider range of service offerings, and, in some cases from reliability improvements. There is also scope for greater innovation in the energy sector.





## Methods

The building block method for revenue determination is typically only applied to regulated monopoly businesses in distribution and transmission. The building block approach has been applied successfully to both electricity and gas. For the segments of the industry which operate in competitive markets, notably electricity generation and retailing, market-based mechanisms are relied upon to produce pricing outcomes.

The available information suggests that WERA is proposing to apply the building block approach to the entire span of operations of the vertically integrated business, the SEC. It is understood that a new regulatory period will commence in 2023. SEC will also be able to rely on a pass-through mechanism in the event that there are increases in fuel costs above a certain threshold.

This study has used empirical methods and forecasts to analyse selected components which will be used by WERA in the building block computation. We have considered how the assessment, by WERA, of the capital expenditure plans of the SEC could be influenced or informed by economic benchmarking techniques.

We have also analysed the range of possible factors that will affect the assessed cost of debt, and cost of equity. For the cost of debt, these factors will include the benchmark credit rating that is adopted, whether a rate on the day measurement or trailing average method is applied, and the likely developments in the spreads for debt, and for credit default swaps for comparator entities. For the cost of equity, important considerations will be the assessed equity beta, and whether forward or backward-looking methods are adopted for the market risk premium.

## Results

The relevant counter-factual is how electricity prices might have evolved under legacy arrangements, in the absence of regulatory oversight, and any form of regulatory framework. Depending upon the degree of scrutiny by WERA, the electricity price outcomes for consumers in the next regulatory period could be higher or lower than those that would emerge in the absence of the imposition of a regulatory framework. Thus, the analysis draws attention to the importance of maintaining a rigorous but transparent regulatory regime.

## Conclusions

We anticipate that under robust regulatory arrangements, there will be modest improvements in capital productivity and labour productivity in the electricity business. The productivity gains will be manifested in the following outcomes:

- Declines, in real terms, in controllable operating costs per unit of output.
- Increases in the available capacity for base-load generating units.
- Reductions in reserve plant margins.

Additional benefits are likely to accrue from the ongoing corporatisation and restructuring of the electricity industry. The most significant gains would result from privatisation.

## References

ECRA, Electricity and Co-Generation Regulatory Authority, Electricity Service Guide, Seventh Edition.

ECRA, Electricity and Co-Generation Regulatory Authority, General Framework of Revenue Requirement Determination Methodology, 2020.

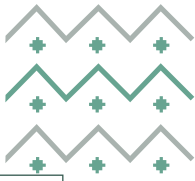
Hasan S., T. Al-Aqeel, and N. Peerbocus, Saudi Arabia's unfolding power sector reform: Features, challenges and opportunities for market integration. KAPSARC, May 2020.

Fitch Ratings, Rating Action Commentary, Fitch upgrades Saudi Electricity Company to 'A'; stable outlook, 19th January 2022.

Industry Commission *Energy Generation and Distribution*, Report No 11, AGPS, Canberra, May 1991; volumes I and II reports.

Trans Advisers, Impact on Victoria of the Privatisation of the State's Electricity and Gas Assets, prepared for TXU Australia, March 2001.





## **POTENTIAL ROLE OF HYDROGEN STORAGE TECHNOLOGY IN THE UK ELECTRICITY GRID**

Saheed Bello, Loughborough University, +447405804586, [s.bello@lboro.ac.uk](mailto:s.bello@lboro.ac.uk)

### **Overview**

Despite the advantages of new renewable electricity sources, the increasing use of these sources in the electricity system leads to uncertainty in the wind and solar electricity production as their generation depends on windspeed and sunshine, thus this creates fluctuation in electricity system operations, mismatches between electricity supply and demand, disrupts the grid stability due to wind/solar excess electricity generation, and amplifies electricity reliability and price issues (Ringkjøb et al., 2018). Consequently, the electricity grid stability is maintained especially when there is excess electricity from non-dispatchable renewable power plants, through electricity waste (termed as curtailment) (Dong et al., 2022).

These above-identified challenges create a room to deploy energy storage technologies that would fasten the decarbonised electricity system, and ensure smoothing operation and reliability of the electricity grid (Aneke & Wang, 2016). Various energy storage technologies have been established in the literature, however, hydrogen storage provides varieties of use such as fuels in the transportation sectors and as chemicals in the industrial sector (Akinyele & Rayudu, 2014). Furthermore, the hydrogen storage provides the best solution to address the problem of wind electricity curtailment (Dong et al., 2022). Therefore, this study investigates the potential role of hydrogen storage technology in addressing wind electricity curtailment in the context of the UK electricity grid.

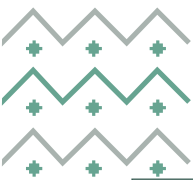
### **Methods**

The study applies a diffusion agent-based modelling (ABM) technique following the features identified in the literature (Akhatova et al., 2022), with the aim to provide investment decision support and scenarios by determining the amount of hydrogen storage required to address the electricity curtailment in the UK electricity transition, thus producing the model outputs (storage capacity, investment cost, profitability and CO<sub>2</sub> emission reduction) for policy recommendations. The study implements the ABM technique by extending its initially developed low-carbon investment simulation model, to include hydrogen storage technology as an additional agent that uses the arbitrage price to make its investment decision rule. Based on this decision rule, the study runs on yearly resolution for time horizons of 30 years between 2021 and 2050, while allowing for technology and market uncertainty.

### **Results**

The study finds that the costs associated with hydrogen storage increase each year from 2021 to 2027 but remain stable up to 2043. Then, a slight increase in the cost from £5millions in 2043 to £5.2millions in 2044, by 2050, its investment cost reaches £5.24millions. However, its positive net present value (NPV) outweighs its investment cost, suggesting high returns on hydrogen storage investment in the midst of high upfront costs. In terms of environmental benefits, about 40 thousand tons of CO<sub>2</sub> emissions are saved between 2021 and 2027, and by 2050, about 57% of CO<sub>2</sub> emissions in 2021 are mitigated from the UK electricity grid. However, hydrogen capacity is quite sensitive to its round-trip efficiency, while higher NPV is associated with higher capital cost and longer lifespan.





## Conclusions

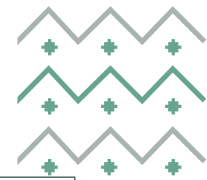
This study quantifies the amount of hydrogen storage required as wind electricity generation increases in the UK electricity grid, in order to address the electricity curtailment. Unlike the previous literature, the paper develops an agent-based modelling framework that incorporates the discounted cash flow approach of hydrogen storage into the UK electricity system evolution, thus its findings lead to the following policy implications:

- As the cost associated with the required hydrogen capacity is about £5.3million by the end of 2050, this requires government supports in stimulating the private investment into hydrogen storage technology.
- Invariably, the ongoing concern on negative welfare consequences of rising carbon price would be resolved, as the hydrogen storage would save more than of 50% electricity generation CO<sub>2</sub> emissions by 2050, the amount of CO<sub>2</sub> saving will be more in future as solar power plants are deployed into the UK electricity transmission grid.

## References

- Akhatova, A., Kranzl, L., Schipfer, F., & Heendeniya, C. B. (2022). Agent-Based Modelling of Urban District Energy System Decarbonisation—A Systematic Literature Review. In *Energies* (Vol. 15, Issue 2). MDPI. <https://doi.org/10.3390/en15020554>
- Akinyele, D. O., & Rayudu, R. K. (2014). Review of energy storage technologies for sustainable power networks. *Sustainable Energy Technologies and Assessments*, 8, 74–91. <https://doi.org/10.1016/j.seta.2014.07.004>
- Aneke, M., & Wang, M. (2016). Energy storage technologies and real life applications – A state of the art review. *Applied Energy*, 179, 350–377. <https://doi.org/10.1016/j.apenergy.2016.06.097>
- Dong, H., Wu, Y., Zhou, J., & Chen, W. (2022). Optimal selection for wind power coupled hydrogen energy storage from a risk perspective, considering the participation of multi-stakeholder. *Journal of Cleaner Production*, 356(October 2021), 131853. <https://doi.org/10.1016/j.jclepro.2022.131853>
- Ringkjøb, H. K., Haugan, P. M., & Solbrekke, I. M. (2018). A review of modelling tools for energy and electricity systems with large shares of variable renewables. In *Renewable and Sustainable Energy Reviews* (Vol. 96, pp. 440–459). Elsevier Ltd. <https://doi.org/10.1016/j.rser.2018.08.002>





## **PRICING SCHEMES FOR SOLAR ENERGY MATTER IN RESIDENTIAL ELECTRICITY USE**

Hideki Shimada, National Institute of Advanced Industrial Science and Technology, +81-29-861-8375, [hideki-shimada@aist.go.jp](mailto:hideki-shimada@aist.go.jp)  
 Tomonori Honda, National Institute of Advanced Industrial Science and Technology, +81- 90-2245-8290, [tomonori-honda@aist.go.jp](mailto:tomonori-honda@aist.go.jp)

Electricity

### **Overview**

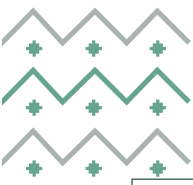
The deployment of residential solar photovoltaic (PV) systems has been and will remain a key approach to realizing the energy sector's decarbonization and curb global warming. A large body of literature has documented that pricing schemes for PV-generated electricity boost the installation of solar PV systems. Broadly, there are two pricing schemes: a gross-pricing scheme, where all generated electricity is sold to electric utilities or grid companies at a given price, and all consumed electricity is delivered using the grid; and a net-pricing scheme, where generated electricity is first consumed by a producer and the surplus, if any, is sold at a given price. These two schemes impose different incentives for electricity consumption once a PV system has been installed. Changes in electricity consumption can be primarily caused by an increase in income under the gross-pricing scheme or by a decrease in the average perceived electricity price under the net-pricing scheme, the so-called solar rebound effect. For a pricing scheme policymaker, it is critical to understand how the schemes affect post-installation electricity consumption, and how they affect welfare. Our study is the first to directly measure the difference in residential electricity usage between the gross-pricing and net-pricing schemes and evaluate how welfare changes. We focus on the Japanese feed-in tariff (FiT), which provides two advantages to this study. First, in Japan, the two pricing schemes coexist, and eligibility for the gross-pricing scheme depends on the capacity of the installed PV system, which provides a fascinating environment for measuring schemes' causal effects on electricity use. Second, data provided by a Japanese house-building company recorded detailed electricity usage and generation information for a large number of households, enabling us to study the two pricing schemes without imputing any electricity use information, which is often observed in the literature.

### **Methods**

We use one-hour interval electricity data of 4,880 households that installed solar PV, covering a broad range of Japanese regions. The data are from a major house-building company. The data include total electricity consumption (i.e., electricity delivered from the grid plus electricity generated and consumed at home), recorded by the company's original electricity monitoring board, and span from 2012 to 2015. Importantly, total consumption, electricity delivered from the grid, total generated electricity, and consumption of generated electricity are separately recorded, which allows us to study actual electricity use and distinguish each household's pricing scheme. We also had access to home and household attributes for most households, including solar PV capacity, total floor area, and average temperature.

Under the Japanese FiT, households can choose between two schemes if their PV capacity is larger than or equal to 10 kW: gross-pricing and net-pricing schemes; they have no choice but a net-pricing scheme otherwise. This study exploits the discontinuity at 10 kW to measure the difference in electricity usage between net-pricing and gross-pricing schemes. We use electricity data spanning from 2012 to 2015 containing households that purchased their homes and installed a solar PV by mid-2015. We choose this period because all households equipped with a PV system larger than or equal to 10 kW chose the gross-pricing scheme, enabling us to apply a sharp regression discontinuity (RD) design. However, a conventional RD design may not be applicable because of the manipulation of a running variable around the threshold if some households (*always-gross households*) installed capacity of just above 10 kW to be eligible for the gross-pricing scheme. Therefore, we also apply the partial identification approach developed by Gerard, Rokkanen, and Rothe (2020) *Quant Econ.*, where the existence of *always-gross households* is allowed and their share is estimated, being utilized to bound the distribution of potential outcomes. The potential outcome of interest here is the hourly electricity consumption under the two schemes.





## Results

Using a simple microeconomic model, we first show that measuring the difference in electricity use between the two schemes is sufficient to determine which scheme is welfare-improving. The net-pricing scheme improves welfare if it incentivizes households to save electricity compared to the gross-pricing scheme. However, we empirically find that electricity usage under the net-pricing scheme is larger than that of the gross-pricing scheme. Point estimates obtained by the conventional sharp RD design suggest that the difference varies over time. The largest hourly difference of 0.12 kWh (11.33 % change compared to the gross-pricing scheme) is observed at 11 AM and is statistically significant at the 1% level, whereas the differences are small in early morning and late at night, and are statistically indistinguishable from zero (Figure 1). The partial identification approach confirmed these results. The estimated confidence interval (kWh) is [0.059, 0.18] at 11 AM. Thus, from the perspective of a social planner, once a solar PV has been installed, the gross-pricing scheme is welfare-improving.

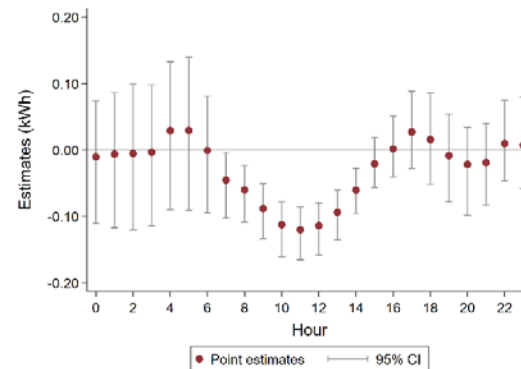


Figure 1: RD estimates

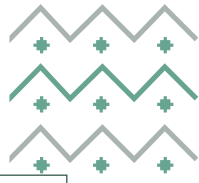
## Conclusions

Our study is the first to directly measure the difference in electricity use between two major pricing schemes for solar energy and empirically show that once a PV system has been installed, the gross-pricing scheme is superior to the net-pricing scheme. This study also contributes to the literature on the rebound effect of solar PV installation on electricity use, where no study has previously examined both schemes. Although we do not directly measure the rebound effects, our results imply that the effects of a decrease in the perceived electricity price under the net-pricing scheme are larger than the effects of an increase in income under the gross-pricing scheme.

## References

Gerard, F., Rokkanen, M., & Rothe, C. (2020). Bounds on treatment effects in regression discontinuity designs with a manipulated running variable. *Quantitative Economics*, 11(3), 839-870.





## ***ELECTRIC VEHICLES, TAX POLICY AND BUSINESS FLEET IN AUSTRALIA: THE TOTAL COST OF OWNERSHIP APPROACH***

Alexandr Akimov, Griffith University, +61755528579  
 Anna Mortimore, Griffith University, +61755528082

### **Overview**

The purchase decision for fleet vehicles strongly depends on the total cost of ownership (TCO) (Hauff 2018). Companies focus on TCO for both battery electric vehicles (BEVs) and internal combustion engine vehicles (ICEVs) (Bloomberg NEF 2021). That is, the TCO is an important metric that enables a cost comparison between a BEV and a similar ICEV, for the costs of owning a vehicle over a specified period, including capital expenditure, operating costs, and resale value. According to Parker et al (2021) comparing the TCO of BEVs and ICEVs has enabled researchers to assess BEV cost-competitiveness under various price, policy, and driving scenarios, evaluate the policy incentives needed to achieve cost parity, and identify the consumer types who would most benefit from BEVs."

The paper applies TCO methodology to compare the BEV and ICEV as business fleet vehicles under the current Australian operating environment and under several modelled tax policy scenarios. It finds that several tax policies have some capacity to bring down large difference in TCO of BEVs and ICEVs. However, these commonly discussed tax policies might insufficient to encourage widespread adoption of electric vehicles by business fleets in Australia. Further policy actions, such as subsidies, might be needed to support Australian government goals of electrifying automotive transport.

### **Methods**

The methodology of estimating TCO for private vehicles is well-established in the literature (see, for example, Hao et al., 2020; Scoranno, Danielis and Giansoldati, 2020; Wu, Inderbitzin and Bening, 2015). In this study, we focus on TCO of a business fleet. In contrast to private vehicles, estimations of the TCO for business fleets should incorporate the prevailing tax environment in the country of study. Hence, we adjust the TCO estimations to account for the taxation impact applicable to business fleet vehicles in Australia.

The estimation of the TCO for fleets is made using the following formula:

$$TCO = IC + \sum_{t=1}^T \frac{AOC_t - ATC_t}{(1+i)^t} + \sum_{t=1}^T \frac{FBT_t}{(1+i)^t} - \frac{RV_t - ITE_t}{(1+i)^t}$$

where  $IC$  is the initial cost of business vehicles, calculated as:

$$IC = VC - DD + DC + SD - SUB + CH$$

in which  $VC$  is vehicle cost,  $DD$  is dealer discount,  $DC$  is dealer delivery charge,  $SD$  is Stamp Duty,  $SUB$  is government subsidy, and  $CH$  is the cost of purchasing and installing home-based charging infrastructure (for a BEV).

In terms of the other parameters of the formula, annual operating cost ( $AOC_t$ ) can be calculated as follows:

$$AOC_t = RC_t + INS_t + RD_t + MAINT_t + TYR_t + F\&E_t$$

where  $RC_t$  is annual car registration fee,  $INS_t$  is annual insurance cost,  $RD_t$  is annual road tax charge,<sup>1</sup>  $MAINT_t$  is annual cost of service and repairs,  $TYR_t$  is the annual cost of tyres, and  $F\&E_t$  is the annual fuel or energy cost (whichever is relevant).

Annual income tax credit ( $ATC_t$ ) is a function of the annual operating cost as follows:

<sup>1</sup> Such as Victorian road user tax of 2.5 c/km.







$$ATC_t = 0.3 \times (AOC_t + Depr_t)$$

where annual depreciation ( $Depr_t$ ) is calculated as 25% of the start-of-year value of the vehicle.

$FBT_t$  represents annual Fringe Benefit Tax expense, calculated using either the statutory or the operating cost methods,  $RV_t$  is the resale value of the vehicle, and  $ITE_t$  is the applicable income tax deduction for the resold vehicle.

In our paper, we test several operational scenarios of business fleet, in terms of holding period and travel distances for two Hyundai Kona variants (BEV and ICEV). We apply several tax treatment scenarios to identify the impact of the potential tax policies on the TCO of both.

## Results

The results can be summarised as follows:

- 1) There is substantial difference in total cost of ownership of BEV and ICEV vehicles in Australia, unfavourable to wider penetration of electric vehicles in Australia.
- 2) Current Fringe Benefit Tax (FBT) arrangements have a strong negative impact on the attractiveness of Battery Electric Vehicles for the business fleet in Australia;
- 3) Battery Electric Vehicles offer substantial savings in terms of operating costs over car ownership period. However, these savings are insufficient to close a substantial price gap of new BEVs and ICEVs.
- 4) FBT waiver for BEVs have capacity to improve attractiveness of the BEV for some business fleet owners.
- 5) For the business that are not subject to FBT, the Total Cost of Ownership difference BEV Kona and ICEV Kona is significant, albeit much smaller than the difference in acquisition costs.
- 6) Instant Asset Write-Off has some capacity to reduce further the Total Cost of Ownership for Battery Electric Vehicle albeit insufficient to fully close the gap in the cost of ownership differential.
- 7) State Government Subsidies play a positive role in improving attractiveness of BEVs. However, the current subsidies in several Australia states are insufficient to fully close the gap in total cost of ownership.

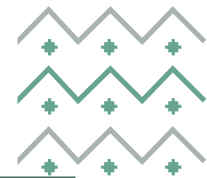
## Conclusions

The paper concludes that several widely discussed tax policies have some capacity to reduce TCO gap between BEVs and their ICEV counterparts. However, further incentives might be required to dramatically improve extremely low penetration of electric vehicles in Australia. They include subsidies, rebates, infrastructure improvements and regulatory changes that would support home charging of business fleet vehicles.

## References

- Bloomberg, NEF. 'Hitting the EV Inflection Point' (2021) 1(58) Transport and Environment. [https://www.transportenvironment.org/sites/te/files/publications/2021\\_05\\_05\\_Electric\\_vehicle\\_price\\_parity\\_and\\_adoption\\_in\\_Europe\\_Final.pdf](https://www.transportenvironment.org/sites/te/files/publications/2021_05_05_Electric_vehicle_price_parity_and_adoption_in_Europe_Final.pdf).
- Hauff, Karin, Stefan Pfahl and Rolf Degenkolb, "Taxation of Electric Vehicles in Europe: A Methodology for Comparison." World Electric Vehicle Journal (2018): 1-11
- Hao, Xu et al. "Range Cost-Effectiveness of Plug-in Electric Vehicle for Heterogeneous Consumers: An Expanded Total Ownership Cost Approach." Applied Energy 275 (2020): 115394
- Parker, Nathan, Hannah L. Breetz, et al., "Who saves money buying electric vehicles? Heterogeneity in total cost of ownership." Transportation Research Part D 96 (2021): 1-16
- Scorrano, Mariangela, Romeo Danielis and Marco Giansoldati. "The Economic Case for Electric Vehicles in Public Sector Fleets: An Italian Case Study." World Electric Vehicle Journal 11 (2020): 1-16. <https://doi.org/doi:10.3390/wevj11010022>
- Wu, Geng, Inderbitzin, Alessandro and Bening Catharina. "Total Cost of Ownership of Electric Vehicles Compared to Conventional Vehicles: A Probabilistic Analysis and Projection across Market Segments." Energy Policy 80 (2015): 196-214





## The Evolution of Electricity Prices and its Impacts on Consumption in Saudi Arabia

Abeer Alghamdi, KAPSARC, 0556881414, [abeer.ghamdi@kapsarc.org](mailto:abeer.ghamdi@kapsarc.org)  
Jeyhun I. Mikayilov, KAPSARC, 0537324174, [jeyhun.mikayilov@kapsarc.org](mailto:jeyhun.mikayilov@kapsarc.org)

### Overview

Saudi Arabia has reformed electricity prices several times since 1984 in an attempt to improve energy efficiency and rationalize consumption while keeping electricity affordable to end users. The relatively low electricity prices in Saudi Arabia have caused a gradual growth in electricity consumption. This study first reviews the history of changes to electricity prices in the Kingdom. There is not a unique publicly available source providing broader information about the evolution of Saudi electricity prices covering all the country sectors. Therefore, the study first aims to shed light on how electricity prices evolved in the Kingdom, investigating its changes across consumer types. It then contextualizes the data by detailing the process of data breakdown by consumption slab. The study utilizes the newly collected price data to model electricity consumption by the government sector at a regional level.

### Methods

Collecting data from different sources, the study highlights the change in the growth rate of Saudi electricity prices over time across the sectors. Data sets were built for the analysis covering tariffs in detail with a breakdown of consumption slabs. The historical electricity price changes with the major end-use sectors data classification have been compiled and summarized into residential, commercial, agricultural, industrial, government, healthcare, private education and charitable institutions. The first part of the study determines only years where electricity prices have changed. The second part covers the more detailed information and separates sectors by tariff segment and consumption slab. The related sectors such as charitable societies and mosques, educational institutions and private hospitals have been combined into one data group for the analysis. The procedure to classify consumption slabs have different stages, i) define the information that can be collected in the data model, ii) divide the consumption into 11 slabs by 1000 kWh difference, starting from 1-1000 kWh segment to >1000 kWh segment, iii) detail the time-period of the price data by month to demonstrate the changes. After having the sector-specific data set, the region-specific government sector electricity consumption will be modeled utilizing cutting-edge econometric estimation techniques. The Augmented Dickey-Fuller (ADF) unit root test will be used to examine the stationarity properties of the variables (Dickey and Fuller, 1981). The cointegration tests developed by Engle and Granger (1987), and Pesaran and Shin (1999) will also be utilized to determine if there are long-term relationships between the variables. Different estimating approaches will be applied to uncover the connections between the variables. In particular, the General to Specific (GETS) modeling technique (Doornik and Hendry, 2018, inter alia), and the Structural Time Series Modeling (STSM) approach (Harvey, 1989) will be used.

### Results

Data breakdown results showed that the electricity prices in Saudi Arabia vary according to the consumption segment/slab and the consumer type. Prior to 1984, different electricity prices were used across the regions of Saudi Arabia. It then indicated that on November 23, 1984, the government introduced new tariffs that were consistent across the Kingdom, distinguishing between two different sectors: industry and non-industry (ECRA 2008). Changes in these tariffs occurred in 1985 in the residential, commercial, and government sectors (which this study focuses on to apply regional level estimations), and remained the same for seven years to 1992, followed by another change in 1995 that remained for five years. Based on the compiled data, a new tariff structure was then introduced in April 2000, with a second minor change in October of the same year. By the end of 2000, the new tariff structure distinguished three different sectors (ECRA 2008). The three price categories were applied and unified for each of the following consumer groups: i) Residential, commercial, and government ii) Agricultural, mosques, and charitable societies iii) Industrial, medical facilities, and private educational institutions.

In 2010, a new tariff structure was implemented that affected the government, commercial, and industrial sectors. This new structure introduced separate tariffs for the commercial and government sectors, which were no longer tied to the residential sector.





Electricity consumption increased gradually in annual basis, while increases to electricity tariffs occurred again at the start of 2016 as part of a wider energy price reform program. The new tariffs for the residential sector, agricultural sector, and mosques and charitable societies were divided into four segments. Conversely, the governmental, hospital and industrial sectors were given one tariff for any quantity of consumption (Akhbaar24 2015).

Saudi Arabia launched new energy price reforms on January 1, 2018, in accordance with Saudi Vision 2030. These included electricity price reform, with the following key goals:

- To improve the government's fiscal position
- To incentivize modest consumption
- To promote a sound investment model in industries
- To redistribute benefits to target segments

(Fiscal Balance Program 2018)

In addition, the government implemented a value-added tax (VAT) with a standard rate of 5 percent that is imposed on goods and services such as water, electricity, and gas. VAT then increased by an additional 10 percent in 2020, totaling 15 percent (Arab News, 2022).

The residential sector experienced a steep increase in electricity prices in 2018. The price increase also occurred in the commercial and agricultural sectors. While governmental, industrial, charitable societies, private hospitals and educational sectors remained the same (SEC 2018). In this study, the compiled data sets determine the years where the price changed multiple times, where the prices of two waves, including the last increase, were applied in the analysis. The model will uncover the region-specific price and income elasticities for electricity demand by the government sector. Then utilizing the estimated models, the study aims to make electricity demand projections/forecasts until 2030 for regions.

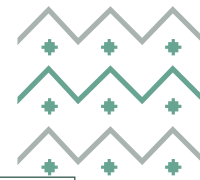
## Conclusions

The purpose of this study is firstly to produce a model data set to serve as a unique publicly available source for the evolution of electricity prices in Saudi Arabia by consumer types. Combining data from different sources, a price data set for electricity ranging from 1984 to 2022 has been generated for further analysis. In addition, the consequences of two price waves, on electricity consumption across sectors during the years 2016 and 2018, have been analyzed. Moreover, considering Covid-19, the sector-specific impacts on electricity consumption have also been investigated. The created data set will be utilized to model the government sector electricity consumption at a regional level. The output of the study will cover the estimated models and projections/forecasts based on those models. The results of the study could be used in policy-making decisions related to overall and region-specific government sector electricity consumption.

## References

- The Electricity & Co-Generation Regulatory Authority (ECRA). 2008. Activity and Achievement of the Authority in 2008.*
- ECRA. 2012. Activity and Achievement of the Authority in 2011.*
- Fiscal Balance Program, 2018. Fiscal Balance Program: Balanced Budget 2020. Vision 2030, Saudi Arabia.*
- Saudi Electricity Company (SEC). 2018. "Billing Services – Consumption Tariffs." Accessed September 8, 2022. <https://www.se.com.sa/en-us/Customers/Pages/TariffRates.aspx>*
2004. Electricity: Growth and Development in Saudi Arabia, 1424–1425 H (2004G). Riyadh: MoWE.
2007. Electricity: Growth and Development in Saudi Arabia, 1427–1428 H (2007G). Riyadh: MoWE.
- Akhbaar24. 2015. "Raise prices of fuel, electricity and water." Accessed September 8, 2022. <https://akhbaar24.argaam.com/article/detail/255091>*
- Arab News, 2022. Accessed September 8, <https://www.arabnews.com/node/1985701/business-economy>*
- SAMA. Saudi Central Bank. 2022. Accessed September 8, <https://www.sama.gov.sa/en-US/EconomicReports/Pages/report.aspx?cid=126>*





## DETERMINANTS OF URBAN HOUSEHOLD COOLING ELECTRICITY CONSUMPTION- EVIDENCE FROM INDIA

[Divya Jain, PhD Scholar, TERI School of Advanced Studies, India,+91 9790466435, divya.jain3@terisas.ac.in]  
 [Gopal K. Sarangi, Assistant Professor, +911171800222, gopal.sarangi.terisas.ac.in]  
 [Sukanya Das, Associate Professor, +911171800222, sukanya.das@terisas.ac.in]

### Overview

The residential sector is the second largest consumer of electricity in India, accounting for 30% of the total energy consumption (IEA, 2020). Moreover, the energy sector is the largest contributor towards greenhouse gas emissions (37%) in India ("India: GHG emissions", 2019). The estimates provided by the IEA (2020) indicate that India's energy demand is expected to increase by 35% between 2019 and 2030. The electricity consumption in urban households includes the use of electrical appliances for cooking (induction-stove), space heating (electric heaters), water heating (electric geysers), cooling (air conditioners, air coolers, and fans), and lighting (tubelights). Compared to other end-uses of energy, the energy used for space-cooling is growing faster and has more than tripled between 1990 and 2016, globally (IEA, 2018). India is one of those countries that is characterized by tropical climate conditions where the number of households owning air conditioners is expected to rise 15-fold by 2040 (IEA, 2020). However, this pattern of residential electricity use varies across states and countries due to their climate attributes, economic factors such as income and electricity price, and household characteristics such as household age, household size, dwelling type, and dwelling size. Household size and household income are the two most common household-specific socio-economic indicators used in the studies carried out in other country contexts (Wangpattarapong et al. 2008; Huebner et al. 2015). Moreover, household income is observed to be a more significant variable in the majority of studies explaining residential electricity demand (Wangpattarapong et al. 2008; Eskeland & Mideksa, 2009) as compared to household size. However, it is crucial to understand that occupant behavior plays an equally important role in determining the electricity consumption within a household. This behavior is governed by the ownership pattern of different appliances and their use based on the climatic conditions prevalent in a region at a particular time-period (Wallis et al. 2016). However, the complex nature of consumer behavior makes it complicated for researchers to capture its influence on energy usage (Chen et al. 2013). Few studies have attempted to analyze these consumer behavioral factors and their linkage with residential electricity demand (Sanquist et al. 2012; Chen et al. 2013; Wallis et al. 2016). To our knowledge, Singh et al. (2018) is the only study in the Indian context that has included the behavioral component in terms of the ownership pattern of different electrical appliances. Their results showed that household electricity consumption is influenced more by the ownership pattern of the air-conditioners than by demographic variables like electricity prices. To fill this gap in the literature, this study aims to address two research objectives: 1) to investigate the changing pattern of household electricity use during summers in Indian states characterized by different climate attributes; and 2) to analyze the role of socio-economic, demographic, and behavioral factors in influencing the urban household cooling electricity consumption within Indian states.

### Methodology

Household survey was carried out within the selected districts of four states, i.e., Rajasthan, Uttar Pradesh, Punjab, and Maharashtra. Five districts (given in the Table below) were chosen as representative of these four states based on two sets of criteria: a) they should belong to different climate zones within each state; and b) they should represent a higher percentage of total state population as well as urban population. In order to examine the importance of socio-economic, behavioral, and demographic factors within a household, a multiple log-linear regression technique was deployed to determine their significance behind the change in residential monthly cooling electricity consumption. A cluster sampling technique was used to select 1053 households for the survey within the five districts of the four mentioned states. A closed-ended questionnaire survey was used to perform the survey during 2019–2020 (summers).

Table : Districts selected for carrying out the survey

DISTRICT	STATE NAME	CLIMATE ZONE
Amritsar	Punjab	Composite
Lucknow	Uttar Pradesh	Composite
Bikaner	Rajasthan	Hot and dry
Aurangabad	Maharashtra	Hot and dry
Nagpur	Maharashtra	Composite





A multiple-linear regression (MLR) model was formed, with monthly household electricity consumption (log-transformed) during summers (KWh) as the dependent variable, and demographic factors (number of members in a household, family composition, and dwelling size), behavioral factors such as usage of electrical appliances (air-conditioners, air-coolers, refrigerators, and fans) during the morning (5:00–9:00), afternoon (13:00–18:00), evening and late-evening (18:00–24:00), and late-night (0:00–5:00), different appliance attributes such as the brand, type, star-rating, and capacity, and socio-economic (family income) factors as exogenous inputs. Due to the presence of a high degree of multicollinearity between family size and other variables, it was dropped from the model. Both standardized and unstandardized coefficients were obtained for all the variables.

## Results

The statistical results of the household survey show that, on average, a household consumes 593 KWh of electricity during the summer, with the highest consumption in Amritsar and the lowest in Lucknow. This can be attributed to the lower household income, smaller dwelling size, usage of all three electrical appliances such as air conditioners, air coolers, and fans in the latter. The daily average number of operating hours of air coolers was observed to be higher than that of air-conditioners (ACs) and fans. Similarly, the average hourly usage of air-coolers on weekdays was higher than that of fans and ACs, whereas on weekends, both air coolers and fans were found to be used for an equal number of hours. As expected, the pair-wise correlation matrix shows that household income, behavioral variables, and demographic variables were positively correlated with residential electricity consumption. In contrast to this, a negative correlation was observed between the number of children in a household and residential electricity consumption. This can be due to the greater engagement and awareness of children in following energy conservation practices at home when compared to adults. The empirical model findings show that both household characteristics and behavioral factors alone account for 32% of the variability in household electricity consumption, leaving aside household income. In contrast to the earlier literature, household income turned out to be insignificant. However, behavioral factors such as the use of air-conditioners during the evening and late-evening, and the usage of fans during the afternoon turn out to be the most significant determining factors behind cooling electricity consumption in urbanized households across the Indian states. This was followed by the number of adults and children within a household.

## Conclusions

In this study, we aim to investigate the major factors that influence the household electricity consumption during the summer season in five districts from two different climate zones. This was based on a household survey conducted within 1053 households. A multiple log-linear regression technique was deployed to determine the significance of the various demographic, socio-economic, and behavioral factors. The factors related to appliance usage time during the day turned out to be most significant in our study. This was specifically true for air conditioners and fans. Hence, behavioral factors related to the usage of appliances should be considered when effectively designing policies in India. The increased consumer awareness on how the inefficient use of electricity contributes to higher emissions and global warming is pertinent. Hence, switching to more energy-efficient practices by households is required in the long run to reduce the carbon footprint of the residential sector. Some of the factors which are not considered in the study such as, the age of household head, electricity price, household type, dwelling age, and behavioral patterns related to other household appliances, can be considered in future research studies. This can add a different dimension to exploring their linkage with electricity consumption. Similar household surveys should be extended to other districts and states within India. Additionally, heating electricity consumption can also be studied in the states where the winter season is prominent.







## COMPETITION AND GREENING OF THE FRENCH RETAIL ELECTRICITY MARKET: THE EFFECTS ON HOUSEHOLD ELECTRICITY PRICES

Sandra Moreno, ART-Dev, University of Perpignan Via Domitia, sandra.moreno@univ-perp.fr  
Sophie Masson, ART-Dev, University of Perpignan Via Domitia, sophie.masson@univ-perp.fr

### Overview

Following the liberalisation of the European energy markets that started in the 1990's, the French retail electricity market was fully opened in July 2007. The liberalisation aimed to increase competition, which theoretically should lead to gains in efficiency and consequently, to decreasing prices for consumers. However, the need for retail competition and the real benefits for consumers have been subject to debate since the liberalisation process started.

Furthermore, in a context of international commitments against climate change, European climate and energy targets have been set to reduce GHG (greenhouse gases) emissions. Among these, the increase of the share of renewable energy sources in final energy consumption up to 20% by 2020 (which has already been reached, according to data from Eurostat) and up to 32% by 2030. In line with this, and according to the French Energy Code, the national energy targets aim to increase the share of renewable energy sources up to 40% of the French electricity generation by 2030.

In this context, several empirical studies have analysed the effects of liberalisation and regulatory market reforms on electricity prices. Most of them, providing analysis for a panel of European countries, while only a few analyses the case of particular countries. Moreover, numerous empirical analyses have demonstrated that the increasing share of renewable energy sources in electricity generation leads to decreasing wholesale electricity prices. With regard to household prices, however, the effect is still ambiguous and has not been largely analysed in the French case.

This paper examines market structure and competition as well as the green retailing development of the French retail electricity market. It aims to assess the development of the market and to provide quantitative evidence of the effect on household prices of retail competition and the *greening* of the market. In other words, we investigate the relationship between household electricity prices and variables related on the one hand, to the *greening* of the market (increased electricity generation from renewable energy sources, increased number of green retailers and green electricity contracts supplying only electricity generated from renewable sources). On the other hand, to the intensity and type of competition in the market.

### Methods

We used data provided by the French Commission of Energy Regulation and by the Data and Statistics' Studies Service (SDES), for the period 2011-2021. Through several statistical indicators, we provide an insight of the French retail electricity market with regard to market structure, competition and its green retailing development. Furthermore, a regression model is developed to study the relationship between household prices and the competition and greening indicators.

### Results

Although the French retail electricity market remains highly concentrated, in this paper, we show that competition is mainly characterised by product innovation with regard to sustainability, in the form of an increasing number of green electricity contracts (green retailing).

With regard to household prices, our statistical analysis suggests a significant price difference between green and conventional electricity contracts for the fourth trimester of 2016. Green electricity contracts being in average significantly more expensive than conventional electricity contracts. However, when analysing for the second trimester of 2021, the price difference between both types of contracts is not statistically significant.







Finally, some preliminary results suggest also that household electricity prices increase with the increasing number of electricity contracts available for consumers and with the increasing share of renewable energy sources in final electricity consumption.

## Conclusions

Fifteen years after its creation, the French retail electricity market remains highly concentrated despite the increasing number of retailers entering the market. According to the French Commission of Energy Regulation, the four largest retailers captured a 97% share of contracts for final consumers in 2019.

Competition is mainly characterised by product differentiation, which is mostly represented by green electricity retailing. With regard to household prices, we found significant evidence of price differences between green and conventional electricity contracts at the earliest stages of the market, with green contracts being in average more expensive than conventional contracts. However, in recent years, this price difference seems to be no longer significant.

Our research is currently going through the analysis of the relationship between household prices and the variables related to competition and the greening state of the market.

## References

- Defeuilly, C. (2009) "Retail Competition in Electricity Markets", *Energy Policy*, 37, 377-386.
- Fiorio, C.V. and Florio, M. (2013) "Electricity prices and public ownership: Evidence from the EU15 over thirty years", *Energy Economics*, 39, 222-232.
- Joskow, P. (2000) "Why do We Need Electricity Retailers? or Can You Get It Cheaper Wholesale?", Working paper, MIT Center for Energy and Environmental Policy Research.
- Littlechild, S. (2000) "Why We Need Electricity Retailers: A Reply to Joskow on Wholesale Spot Price Pass-Through", *Cambridge Working Papers in Economics*.
- Moreno, B., Lopez, A.J., Garcia-Alvarez, M.T. (2012) "The electricity prices in the European Union. The role of renewable energies and regulatory electric market reforms", *Energy*, 48, 307-313.
- Mulder, M. and Willems, B. (2019) "The Dutch retail electricity market", *Energy Policy*, 127, 228-239.





## Effective load carrying capacity ("ELCC") of solar photovoltaic ("PV") resources in a KSA context

A.J. Goulding, President, London Economics International, LLC (LEI), +1(416)643-6610, [ajg@londoneconomics.com](mailto:ajg@londoneconomics.com)  
Amit Pinjani, Director, LEI, +1(647)963-7005, [amit@londoneconomics.com](mailto:amit@londoneconomics.com)  
Victor Chung, Managing Consultant, LEI, +852-9040-1354, [victor@londoneconomics.com](mailto:victor@londoneconomics.com)  
Shashwat Nayak, Senior Consultant, LEI, +1(647)616-4369, [shashwat@londoneconomics.com](mailto:shashwat@londoneconomics.com)

### Overview

For power system planning purposes, resources have historically been assigned capacity credit consistent with the extent to which their output could be relied upon to offset peak load. For intermittent resources, historical or expected daily and seasonal output profiles have been correlated with load shapes to assess their contribution to serving peak load. In North America, the concept of effective load carrying capacity ("ELCC") has been developed as a means to frame the discussion about the role of intermittent resources and the extent to which additional back up capacity is required.

At increasing levels of penetration by solar photovoltaic ("PV") resources, there is a risk that subsequent additions may provide little or no augmentation to the system's capability to meet peak load. This situation is exacerbated if there is a significant amount of behind the meter ("BTM") solar installed, as the system peak (net load) may consequently peak as production from both utility scale and BTM solar abates in the evening.

In North America, this challenge may become more acute as a result of electrification of heating, as winter peak demand is likely to occur after dark, rendering PV of little reliability value during several months of the year. While the interconnected nature of continental electricity systems may allow for some sharing between time zones, the transmission system is not adequate to allow for balancing across four time zones, nor would time differences alone be sufficient to address the issue.

The situation in Kingdom of Saudi Arabia (KSA) is different; load profiles are different from North America, the potential solar PV resource is more extensive, electric heating load is low, and BTM penetration less significant. Nonetheless, the role of solar PV needs to be carefully considered in a KSA context.

### Methods

In this paper, the authors shall take the following approach:

- Review the approach to calculating ELCC in the PJM Interconnection and other US independent system operators ("ISOs");
- Based on publicly available information regarding KSA load profiles and PV production curves, assess PV ELCC today in KSA, being mindful of potential regional differences;
- Review solar PV targets for KSA and assess corresponding PV ELCCs in target years given expected load growth but assuming no change in load profile; and
- Assess PV ELCCs based on scenarios regarding BTM solar penetration and the impact on load profiles.

### Results

The following outcomes shall be presented based on the undertaken analysis:

- Determine whether targets for dispatchable resources (batteries, fossil fuel, demand response) in target years reflect system needs given PV ELCC, with and without solar BTM penetration; and
- Recommend adjustments to targets if appropriate.

### Conclusions

The results from this study will help us to understand the resource portfolio needs for KSA in the near future when integrating increasing levels of solar PV into the grid, and recommend adjustments to the current targets if appropriate.





## [LIGHTING THE PATH: *CHALLENGES AND OPPORTUNITIES IN MENA POWER SECTORS*]

[Jessica Obeid, Non-Resident Scholar- Middle East Institute, +447401717544, jessica@obeid.re]

### Overview

This paper provides a comprehensive review of the current state of the electricity sector across six countries in the Middle East and North Africa (MENA) region, specifically Saudi Arabia, Oman, Lebanon, Jordan, Egypt and Morocco. The paper highlights the major challenges facing electricity utilities including the unsustainable growth in power demand, the significant losses and fiscal deficit, the growing dependence on natural gas, the limited grid status, the detrimental effect of subsidies, and the impact of climate change and rising temperatures on the sector's performance.

Despite the wide disparities across the region and the expanding gap in the capacity to reform and invest in the power sector, these challenges are common trends at various extent levels within these six countries. The paper analyses the power sector status from an energy security and climate change lense while reflecting on the sector's prospects under the business-as-usual scenario.

The analysis show that there is some progress in the majority of the countries in addressing these challenges at diverse scales and effectiveness, but that reforms are not linear and are dependent on a series of factors including governance, institutional strength and ability to attract investments. The paper finally suggests that opportunities are present to enhance the power sector's performance, climate resilience and energy security through energy conservation and storage, renewable energy deployment, and connectivity.

### Methods

In this paper we study extensively the power sectors of Saudi Arabia, Oman, Lebanon, Jordan, Egypt and Morocco to compare different metrics and changes across time in electricity demand, installed and available capacity, fuel source for power generation, cost of generation and recovery, tariff subsidies, fiscal performance, technical and non-technical losses, and System Average Interruption Duration Index. The six countries are selected to reflect different categories of MENA countries, through: 1) regional segregation into Gulf states, Levant and North African countries, and 2) economic segregation into high, middle and low-income countries, and petroleum-producers and net-energy importers.

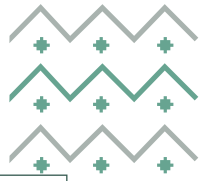
The research is evaluated and supplemented with official and publicly available documents and conversations and extensive discussions with experts in the field in the studied countries. The methodology therefore involves analysing various sources and interpreting the metrics through a thorough comparison to draw results and conclusions for more sustainable power sectors.

### Results

The power sectors are recording unsustainable growth in demand driven by the fuel and electricity subsidies, growing population and economic activity, climate change impact on cooling and water needs, electrification of sectors such as transport, and digitization.

The growth however has witnessed a downward trajectory in certain countries such as Saudi Arabia and Egypt in the last five years compared to a decade earlier. Egypt's annual growth averages slightly less than 4%. Saudi Arabia has seen its electricity demand growth exceeding 4% in 2021, after a couple of years of decline.





This growth has been driving a race for additional power generation capacity in the region, and this capacity is increasingly reliant on natural gas, which most countries do not produce at all or do not produce enough of to meet the growing demand. Gas is currently the source for 52% of power generation in Saudi Arabia. In Lebanon, gas is still not part of the energy mix, but is required to decrease the cost of electricity recovery.

Fossil fuel subsidies have been detrimental to the performance of the power sector. Despite the many plans to phase them out, the implementation of price restructures has lagged and is becoming increasingly difficult with the volatile price of oil, for socio-economic and political reasons.

Even though there are disparities across countries, planned power sector projects in the region top the energy sector's investments. The bulk of investments however targets the generation sector, and only a minor share is allocated for transmission and distribution networks.

Climate change and extreme weather events increasingly impact all components of the power systems. They also affect the availability of primary energy sources. The impact of climate change is witnessed in the increase of cooling and water demand leading to record peak demand in mid-summer heat.

Most of these countries have implemented reforms in the power sector, mainly in tariff restructure. But economic and political changes have led to a non-linear path of reforms.

Key factors in mitigating the power sector challenges are sectoral governance, institutional strength and ability to attract investments.

The way forward requires doubling-down efforts in energy efficiency measures implementation and solid action plans and investments for renewable energy plus storage.

Further action is needed to integrate and optimize the three separate grid interconnections in the region to mitigate the race for additional power generation capacity and better integrate renewables.

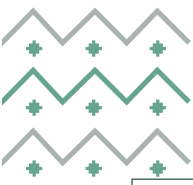
## Conclusions

The growth in power demand is unsustainable driving an unhealthy race to additional power generation. The power sectors also suffer from unhealthy financial performance impacting the utilities' ability to invest, especially in non-attractive sectors such as transmission and distribution. Energy security is compromised and further aggravated by the impact of climate change.

Decision makers should account for all these factors in developing electricity policies and projects, and should consider strengthening climate resilience as an integral part of the power systems.

Chartering a sustainable and energy secure path requires going back to basics and doubling-down efforts in energy conservation, integrating clean and storage systems, and building an efficient electricity exchange market.





## Submission Summary

### Conference Name

44th IAEE International Conference - 2023

### Paper ID

353

### Paper Title

WHAT DO WE KNOW ABOUT ELECTRICITY DEMAND ELASTICITIES WITH IMPLICATIONS FOR THE FUTURE?

### Abstract

#### Overview

Electricity demand has been one of the longest and most heavily studied of energy products with the first econometric study found published in 1951. My last survey paper relating to electricity, Dahl (2011a) cites 7 studies between 1974 and 2005 that survey or do meta-analyses on electricity demand elasticities. These eight studies span more than 400 econometric electricity demand studies dated between 1951 and 2008. Summary statistics for each of the more than 400 articles are included in the database Dahl (2011b). With electricity currently providing around a quarter of the global anthropomorphic emissions of CO<sub>2</sub> (EPA 2022), electric cars looming on the horizon (10% of new light duty vehicle purchased were electric in 2021 (IEA 2022) and more than 700 million people currently without access to electricity (Worldbank, 2022), this interest has not waned. Since my last extensive database update of electricity demand elasticities (Dedd2011\_EI), more than 100 new studies have been found, which contain electricity demand elasticities and two studies do metanalysis. (Labandeira, Labeaga, and López-Otero, 2017) consider all demands for electricity for papers published from 1990-2016 while (Zhu, Li, Zhou, Zhang, and Yang, 2018) consider only residential demand for electricity on papers published from 1990-2016. My goal in this paper is to build on the impressive array of survey work already completed by first gleaning what conclusions they provide and then consider the more than 500 studies collected to find what additional information they provide that can help us better understand electricity demand and how it has evolved.

#### Methods

The survey work and meta analyses typically consider a number of categories to see their effect on estimated price and income demand elasticities in the short- and long-run and elasticities on static models which do not distinguish between short and long run. Categories can include sectors, data types and frequency, income levels, geographic regions, time period, environmental characteristics, functional form, and econometric methodology. I will begin there as well and compare and contrast the existing surveys. I will then dig deeper and add the more than 100 new electricity demand studies to my existing publicly existing database on electricity demand. Histograms and statistical measures will provide an overview of this rich and most up to date database that considers the demand for electricity for all countries and sectors. The database includes not only the price and income elasticities and categories typically included in the survey work but all the variables included in the estimated equations. This will allow consideration of the effects of other variables that are not as well studied.

#### Results

From considering the survey work, I will conclude where they agree, where they disagree, where the most uncertainty lies, and important questions that remain to be answered. Then I will proceed to consider the original articles I have collected over the years to do a critical analysis of these available studies, summarize what additional variables have been included, and determine what if anything we can infer about their effect on electricity demand and elasticities. Such variables will include weather, urbanization, and variables relating to policy. Additional I will focus more specifically on topics where less survey work has been done including electricity demand in the poorest of countries, cross price elasticities, elasticities by time of day and electricity demand by industry, which shows rather large variation.

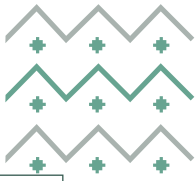
#### Conclusions

Understanding the likely value of demand elasticities in the past, how they have evolved, and what drove electricity demand growth is important information for a whole host of stakeholders including electric utilities, international capital markets, electricity consumers, electricity regulators and other policy makers interesting in providing clean and





# PROCEEDINGS OF THE 44<sup>TH</sup> IAEE INTERNATIONAL CONFERENCE "PATHWAYS TO A CLEAN, STABLE, AND SUSTAINABLE ENERGY FUTURE"



Electricity



Conference Management Toolkit - Submission Summary

<https://cmt3.research.microsoft.com/IAEEConference2023/Submissio...>

affordable electricity to the global population. The ongoing database should prove valuable to them as well. More importantly, the results from the past will be used to speculate about implications for the future and needed research as we march towards net zero.

#### References

Dahl, Carol A. (2011a) "A Global Survey of Electricity Demand" The 34th IAEE International Conference: Institutions, Efficiency and Evolving Energy Technologies, June 19-23, Stockholm School of Economics, Sweden and (2011b) "Dahl Energy Database for Electricity (Dedd\_EL2011). Work in progress. [http://dahl.mines.edu/courses/dahl/DEDD\\_EI2011.xlsx](http://dahl.mines.edu/courses/dahl/DEDD_EI2011.xlsx).

U.S. Environmental Protections Agency (2022) Global greenhouse gas emissions data. (<https://www.epa.gov/ghgemissions/global-greenhouse-gas-emissions-data>)

World Bank (2022) World Development Indicators. (<https://datacatalog.worldbank.org/dataset/world-development-indicators>)

International Energy Agency (2022) Global EV Outlook 2022: Executive Summary. (<https://www.iea.org/reports/global-ev-outlook-2022/executive-summary>)

Labandeira, Xavier, Labeaga, José M., and López-Otero, Xiral. (2017). A meta-analysis on the price elasticity of energy demand. *Energy Policy*, 102(Supplement C), 549-568. <https://doi.org/10.1016/j.enpol.2017.01.002>.

Zhu, Xing, Li, Lanlan, Zhou, Kaile, Zhang, Xiaoling, and Yang, Shanlin. (2018). A meta-analysis on the price elasticity and income elasticity of residential electricity demand. *Journal of Cleaner Production*, 201, 169-177. [10.1016/j.jclepro.2018.08.027](https://doi.org/10.1016/j.jclepro.2018.08.027).

---

#### Created on

9/12/2022, 9:10:40 AM

---

#### Last Modified

9/12/2022, 9:10:40 AM

---

#### Authors

**Carol Dahl** ( Colorado School of Mines ) < [cadahl@mines.edu](mailto:cadahl@mines.edu) > ✓

---

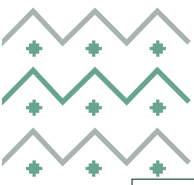
#### Primary Subject Area

Electricity

---







## Ukrainian crisis and market power in the Italian electricity market

Carlo Andrea Bollino, Department of Economics, University of Perugia, via A. Pascoli, 20, 60123, Perugia, Italy,  
Phone: + 39 0755855421, Fax: +39 0755855299, e-mail: [carloandrea.bollino@unipg.it](mailto:carloandrea.bollino@unipg.it)

**Keywords:** Market power; Zonal lerner index; Mark-up; electricity market; Ukraine crisis

### Overview

The Italian electricity market was characterized by a gradual increase in prices since September 2021 and a remarkable increase in prices after the burst of the Ukraine crisis, with record prices of about 800 Euro/MWh. This paper aims to investigate the exercise of market power in the Italian power exchange during the crisis. The cointegration of oil, gas and electricity price is preliminarily analyzed and then the Zonal Lerner Index is computed for every hour in January–September 2022 for the main operators on the supply side in the Italian day-ahead market. Furthermore, we analyzed the correlation between market power and the effect of the crisis in specific periods. The results showed that the exercise of market power on the supply (mark-up) sides was considerably changed during peak hours and in specific off-peak hours. Overall, the main players have somehow increased the intensity of market power during the Ukraine, which calls for a reform of the market regulation and more pro-competitive action by the regulatory authority.

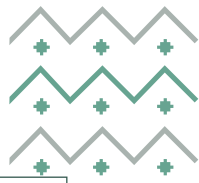
### Methods

We used a unique data set of about 100 million individual demand and supply bids in the Italian electricity market for the period 1 Jan to 30 September 2022, taken from the databases of the Italian market operator—Gestore Mercato Elettrico (GME). Data are daily and provide all offers to buy and sell blocks of electricity in the day-ahead market. This information is publicly available, according to Article 2, paragraph 2.1 of the Decree of the Ministry of Economic Development of 31 July 2009. The method was developed in two stages. In the first stage, for each hour of the study period, we computed the Zonal Lerner Index (ZLI) for the main strategic players (in the demand and supply sides) using the inverse of the residual supply-demand functions. The computed hourly ZLIs proxy the market power exercised by the main operators. Then, in the second stage, the computed hourly ZLI were regressed on some variables expressing the main structural features of an electricity market, including the dummies representing the different periods during the outburst of the Ukraine crisis.

### Results

We tested the following hypotheses on the supply side: H1. The exercise of market power on the supply side increased during the crisis; H2. The stricter lockdown is associated with an increase in the exercise





of market power during the evening hours; H3. A decrease in market power occurs when RES is the marginal technology.

First, we observed a general increase of the ZLI levels during the crisis period, with respect to the previous period (1 Jan to 24 Feb).<sup>11</sup> Second, the strict lockdown period showed that all suppliers are characterized by ZLI values larger during midday hours than evening hours.

Second, we note a trend reduction in the exercise of market power compared to the previous period in the hours where no congestion, but when the market was segmented into three-zones, the mark-up generally increased for almost all operator in the same periods.

Third, the Market power increases during the crisis period, when the marginal technology setting the equilibrium is the market coupling with other European markets. Fourth, considering the market energy mix, empirical results showed that the share of RES contributed significantly to lower the exercise of market power.

### Conclusions

These findings have relevant policy implications for designing a new market reform and a new regulatory strategy to monitor the market during exceptional times and improve efficiency in the Italian electricity market. The fact that the HHI did not change significantly during the exceptional time but the Lerner index changed for the worst, it is a clear indication that the Regulatory Authority has to adopt monitoring instruments that need to be more efficient,

### References

- Bigerna, S., Bollino, C.A., Polinori, P., 2016a. Market power and transmission congestion in the Italian electricity market. *Energy J.* 37 (2), 133–154. <https://doi.org/10.5547/01956574.37.2.sbig>
- Hesamzadeh, M.R., Biggar, D.R., Bunn, D.W., Moiseeva, E., 2020. The impact of generator market power on the electricity hedge market. *Energy Econ.* 86, 104649.
- Hortacsu, Al, Madanizadeh A., Seyed, Puller L., Steven, 2017. Power to Choose? An Analysis of Consumer Inertia in the Residential Electricity Market. *Am. Econ. J. Econ. Pol.* 9 (4), 192–226. <https://doi.org/10.1257/pol.20150235>
- Wolak, F.A., 2003. Measuring Unilateral Market Power in Wholesale Electricity Markets: the California Market 1998 to 2000. " *American Economic Review*, pp. 425–430. May.
- Wolak, F.A., 2009. Report on Market Performance and Market Monitoring in the Colombian Electricity Supply Industry. Retrieved from. [http://web.stanford.edu/group/fwolak/cgi-bin/sites/default/files/files/sspd\\_report\\_wolak\\_july\\_30.pdf](http://web.stanford.edu/group/fwolak/cgi-bin/sites/default/files/files/sspd_report_wolak_july_30.pdf). Zhong, H., Tan, Z., He, Y., Xie, L., Kang, C., 2020. Implications of COVID-19 for the





## Decarbonizing Medium and Heavy-Duty On-Road Vehicles

Matteo Muratori and Catherine Ledna; National Renewable Energy Laboratory, [matteo.muratori@nrel.gov](mailto:matteo.muratori@nrel.gov)

### Overview

Achieving a net-zero emission economy by 2050 requires aggressive curbing of transportation emissions across all passenger and freight travel modes. This will require a combination of changes to travel behavior, urban planning, accessibility and availability of various travel modes, technology and infrastructure deployment, and policies that will work together to reshape future mobility systems in various world regions. Despite growing interest in deep transportation emissions reductions, the pathways to achieve ambitious goals remain highly uncertain. Medium and heavy-duty vehicles (MHDVs) are a substantial source of greenhouse gas emissions, accounting for 21% of transportation sector carbon dioxide emissions in the United States, and are largely responsible for poor air quality disproportionately affecting disadvantaged communities, for example around ports. Transitioning to zero- and low-emission technologies in this market segment is a high priority to achieve net-zero emission goals by 2050. We analyze the decarbonization potential of MHDVs across multiple vehicle classes and market segments, exploring a range of technology improvement trajectories and market conditions for battery-electric vehicles (BEVs) and hydrogen fuel cell electric vehicles (FCEVs).

### Methods

We use the Transportation Energy and Mobility Pathway Options (TEMPO), a system-level model, to estimate the economic feasibility of technology transitions by comparing the total cost of driving of conventional diesel and zero-emission technologies, including upfront purchase costs, fuel costs, maintenance costs, and the monetized cost of dwell times when recharging BEVs (in circumstances where driving distance requires intra-day recharging). We estimate vehicle sales shares using a logit formulation, which captures heterogeneities in adoption across the market. Vehicle sales, stock, energy consumption, and carbon dioxide emissions are estimated for the years 2019 to 2050. Our scope includes three size classes covering vehicle classes 3 to 8 and eight shipment distance bins, representing differences in vehicle travel. Distinct from previous studies which estimate decarbonization potential for a subset of vehicle types and applications, this approach allows us to evaluate the decarbonization potential of the full medium and heavy-duty sector in the United States.

### Results

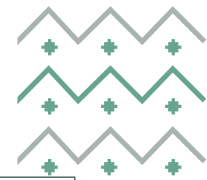
Our findings show that multiple technology options are viable for decarbonizing MHDVs, with BEVs and FCEVs playing complementary roles. We find that short-range (150 mile) BEVs can become cost-competitive in short-range applications (with annual vehicle-miles traveled of less than 100,000 miles) and for lighter vehicles (classes 3-6). For long-range and heavier vehicles (Class 7-8 vehicles with annual vehicle-miles traveled of more than 100,000 miles), a mix of FCEVs and long-range (500 mile) BEVs become cost-competitive with conventional vehicles due to the longer distances traveled, which result in increased fuel cost savings that offset higher capital costs. In general, under Central scenario assumptions, we find that zero-emission vehicles in short-range and lighter applications achieve cost parity with conventional vehicles on an earlier timeframe (between 2026 and 2032), while heavy vehicles that travel longer distances take longer to achieve cost parity (by 2035 in most market segments) but are responsible for the majority of emissions savings. Despite 55% growth in assumed annual vehicle-miles traveled from 2019 to 2050, emissions are reduced by 69% in 2050 relative to 2019. The greatest emissions reductions per vehicle are achieved for heavy-duty long-haul vehicles, which drive the longest distances and have the lowest conventional fuel economy.

These outcomes are subject to substantial uncertainties, which we explore in multiple sensitivity analyses. In particular, fuel prices and charging speeds are highly uncertain and vary by location and for different vehicles and distances. We evaluate multiple fuel cost and technology improvement trajectories spanning a range of both conservative and optimistic assumptions for zero emission and conventional vehicles and fuel technologies. We find that the relative share of BEV and FCEV technologies is strongly influenced by electricity and hydrogen fuel prices, particularly in high-mileage market segments where fuel cost savings play a greater role in total cost of driving (see Figure 1).



Renewables





Renewables

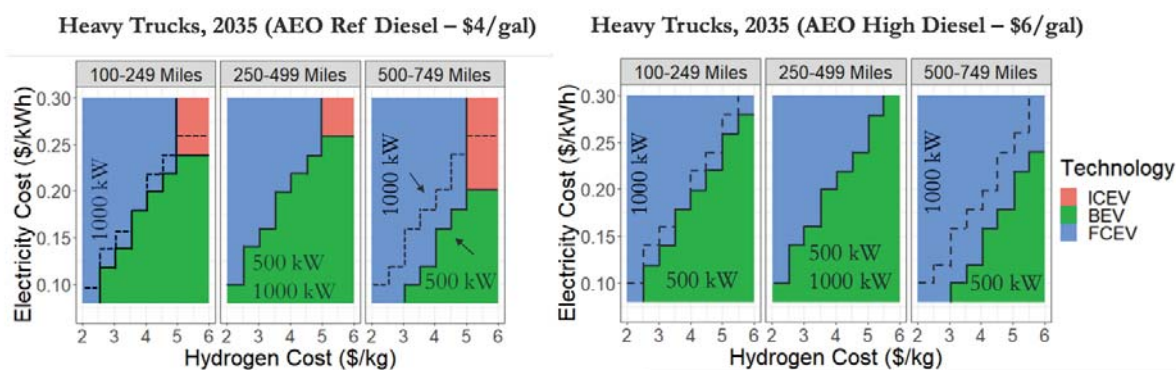


Figure 1. Impact of fuel prices on least-cost truck technology. Under high diesel price assumptions, BEVs and FCEVs are expected to dominate the market. Hydrogen becomes most competitive in longer shipment distances (higher VMT) and at higher electricity prices. 500 kW (solid lines) and 1000 kW (dashed lines) charging speeds are also considered, illustrating how reducing dwell time penalties improves the viability of BEVs.

Results are also sensitive to the rate of technology improvement for conventional and zero-emission vehicles and to the financial horizon considered for future fuel cost savings (limited to the first three to five years of ownership under Central assumptions). Across the eight scenarios we consider, we find that emissions reductions in 2050 range from 27% to 77% relative to 2019, with greater emissions reductions induced by lower hydrogen and electricity prices and more rapid rates of technology improvement for zero-emission vehicles.

### Conclusions

We analyze the decarbonization potential of medium and heavy-duty vehicles (MHDVs) across multiple vehicle classes and market segments. We evaluate the timeframe in which zero-emission vehicles (ZEVs) could achieve cost parity with conventional diesel vehicles and the implications for energy and emissions. Our results show that ZEVs can achieve cost parity with conventional vehicles by 2035 across the majority of vehicle classes and market segments. Emissions reductions range from 27% to 77% by 2050 relative to 2019 across multiple fuel cost and technology progress sensitivities. Multiple technology pathways are viable for decarbonization, including battery-electric vehicles and hydrogen fuel cell electric vehicles.





## **Production potential and economic viability of green hydrogen in Algeria**

**Nadjib DROUICHE\***

**\*Agence Nationale de la Valorisation des Résultats de la Recherche et de Développement Technologique(ANVREDET)**

**email : [n.drouiche@mesrs.dz](mailto:n.drouiche@mesrs.dz); [nadjibdrouiche@yahoo.fr](mailto:nadjibdrouiche@yahoo.fr)**

### **Summary**

In April 2021, the Algiers Declaration on the green hydrogen plan was signed by Ministry of higher education and ministry of energy transition and renewable energies. It represents the first step of a plan to develop the green hydrogen industry in Algeria.

The Algiers Declaration's vision is to move gradually towards clean energies, including green hydrogen, and to prepare Algeria's energy transition for 2035. It also goes towards limiting the over exploitation of fossil fuels, which are in continuous decline, and their negative impact on the environment. In order to achieve that goal and despite the economic disruptions caused by the COVID-19 pandemic, there are a number of large-scale renewable energy projects ranging from 50 to 300 MW in the pipeline, amounting to 15000 MW, with over totality being solar power. The declaration would be a milestone towards a National Hydrogen Strategy.

Indeed, compared to Europe, Algeria has world-class largely untapped solar resources, whereas Europe has a growing energy demand needing to decarbonize in line with the Paris Agreement and the UN Sustainable Development Goals.

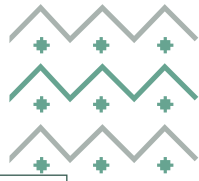
Moreover, the demand for green hydrogen in Europe is expected to be tremendous by 2030-2050. It is to notice that among the European states, Germany has a close interest in green hydrogen as part of its support for low emissions technologies.

The value of Algerian green hydrogen including green ammonia (PtX technologies) exports is not estimated yet but represents a huge potential. Thus, Algeria has to position itself to take a sizable portion. This will be subjected to an effective political good will based on attractive policies such as win-win collaboration opportunities that would contribute to the diversification of the economy and offer job opportunities. Moreover, the Algerian green hydrogen could fulfill the local demand and supply Europe.

Thus, to reach these objectives, a strategy should be initiated to build Algeria's green hydrogen industry. The strategy would begin with a plan to accelerate the replacing







of grey hydrogen production by green hydrogen, the reducing of technical uncertainties, the build-up of a domestic supply chains, and the production capabilities. A strong domestic hydrogen sector will underpin Algeria's exporting capabilities to make it a leading global green hydrogen player.

However, a detailed analysis of hydrogen production from renewable sources, considering the capital expenditure, the OPEX costs, and any other expenses seems a compulsory task to evaluate the project feasibility, its advantages and drawbacks.

It is to notice that all the wilayas of Algeria have excellent prospects for hydrogen production, have the possibility to switch to green hydrogen from the grey hydrogen used for the local market, notably for the production of ammonia and glass. Through adoption of such strategy, removing barriers to industry development and encouraging investments would consolidate the realization of the project.

In the framework of the project, our consultations with different industries involved in hydrogen production and utilization showed that Algerian companies are ready to apply their ingenuity and considerable experience to produce and use of green hydrogen. The best way to start is an effective coordination and cooperation between the government and industry sector to work together to implement a national strategy.

Algeria has qualified human resources, and the experience, to take advantage of increasing upcoming worldwide demand for clean hydrogen. An integrated low-cost renewable generation will reduce dependence on fossils fuels, and helps local reducing carbon emissions

A key element of Algeria's approach will be to create hydrogen hubs – clusters of large-scale demand. These may be at ports, steel and glass industry, ammonia production, or in regional or remote areas. Hubs would make the development of infrastructure more cost-effective and foster research and innovation. These will be complemented and enhanced by other early steps to use hydrogen in heavy transport, industry and gas distribution networks, and integrate hydrogen technologies into the electricity production in a way that enhances its reliability.

Algeria aims at having an important renewable energy share in its electricity system and develops green hydrogen industry, and is well positioned to become a global leader in exporting renewable hydrogen if the appropriate research informed effective policies are put in place. A timely energy transition is needed to accelerate renewable uptake and advance the budding renewable hydrogen industry.

Such efforts can support Europe to decarbonize its industry, meeting Paris Agreement and sustainable Development Goal agendas, while establishing an Algeria's economy diversification.

This paper provided a brief summary on the current policy framework and economic prospects of green hydrogen that are intended in Algeria.







## ***GRID-CONNECTED RENEWABLE POWER SYSTEM WITH ELECTRIC VEHICLE CHARGING STATIONS FOR CAR PARKS ON ACADEMIC CAMPUSES***

[Shafiqur Rehman, Interdisciplinary Research Center for Renewable Energy and Power Systems (IRC-REPS), King Fahd University of Petroleum and Minerals, Dhahran-31261, Saudi Arabia, +966502085496, [srehman@kfupm.edu.sa](mailto:srehman@kfupm.edu.sa)]

[Abdul Baseer Mohammed, Mechanical & Manufacturing Engineering Technology Department, Jubail Industrial College, Jubail, Saudi Arabia, +966508855477, [baseer\\_m@jic.edu.sa](mailto:baseer_m@jic.edu.sa)]

[Fahad A. Alsulaiman, Interdisciplinary Research Center for Renewable Energy and Power Systems (IRC-REPS), King Fahd University of Petroleum and Minerals, Dhahran-31261, Saudi Arabia, [fahadas@kfupm.edu.sa](mailto:fahadas@kfupm.edu.sa)]

### **Overview**

The global electricity consumption was estimated to be 30,000 TWh in 2019 which is predicted to be doubled by 2050 and >1/3<sup>rd</sup> of this energy is expected to be generated from the wind and the solar energy sources (Cloete, 2019). Saudi Arabia consumed around 350 TWh of electricity in 2019 (IEA, 2020). Currently, Saudi Arabia uses one-third of the daily oil production for electricity generation (Felimban et al., 2019). With the depletion of the fossil fuel resources, Saudi Arabia is ardently exploring alternate sources of energy to meet its increasing demands. The population increased by more than 500% in the last four and a half decades ("General Authority of Statistics, Saudi Census," 2015); and during the same period, the number of industries increased by around 35 times ("Saudi Industrial Development Fund, SIDF," 2019). By 2030, the projected demand for energy is expected to exceed 120 GW/year. According to the government's initiative, an initial target of 9.5 GW is set (Kingdom of Saudi Arabia and Saudi Vision 2030, 2016). Moreover, Saudi Arabia also aims to reach net zero by 2050.

In this study, a comprehensive techno-economic feasibility of generating grid-connected renewable energy mainly by using solar photovoltaic, PV panels, and commercially available horizontal axis wind turbines is conducted for a car parking lot at KFUPM, Dhahran, Saudi Arabia. The system design will also cater to a considerable EV charging load of around 20 sessions per day for various EVs. The huge primary load of 20,000 kWh/day with EV charging facility is also new to this region. This large solar parking area along with the EV charging facility and detailed costing analysis of the design with project parameters is the novelty of this study. According to the Saudi Vision 2030, the utilization of renewable energy is high on the agenda of the nation with an initial goal of generating 9.5 GW of renewable energy by the end of 2030. Moreover, three new cities NEOM, AMARA, and RED SEA are under development and are planned to be meeting 100% of their energy from renewable energy. The transport sector is critically important and hence car charging facilities have to be developed and the present study is an initiative towards the same. This will lead to increased renewable energy penetration in the existing energy portfolio and will help in reducing reliance on fossil fuels for power generation. The feasibility of charging the electric vehicles from the power generated using renewable sources will be vital for future usage in green cities like NEOM.

### **Methods**

Firstly, the parking lots at KFUPM were identified. The monthly averaged daily solar global horizontal irradiance (GHI -kWh/m<sup>2</sup>/day), from a data set of around 22 years, was used as input in HOMER software. In parallel, the location was assessed for the suitability of installing commercial horizontal axis wind turbines of suitable rated power. For the assessment of the suitability of the area, ArcMap, the core module of ESRI's ArcGIS collection of software programs is used in addition to personal visits. The campus was not found suitable for the installation of commercial wind turbines as there was no clear suitable area. Finally, a grid-connected solar car park was designed with a converter and battery storage (Baseer et al., 2019, 2015; Baseer et al., 2017(a and b)). The peak solar irradiance and annual averages clearness index (CI) is analysed for this site. In addition, for locations that are suitable for wind turbine installations, the hourly averaged wind speed and direction be obtained from long-term historical weather records.

In the next step, the specifications of the suitable PV panel were identified. The technical and economic data such as capital, replacement, operations, and maintenance cost, and lifetime of each of the components used in this study are obtained from reliable literature resources and software. The optimum grid-connect hybrid power system is designed with daily average power generation in kWh, peak power generation in kW, Cost of energy, COE in USD/kWh, initial capital, net present cost, NPC in USD, and payback time.

### **Results**

A grid-connected solar car park with a net metering scheme is designed to meet primary and EV charging loads of 20,000 kWh/day and 578 kWh/day respectively. The proposed PV system was simulated using HOMER Grid 1.8. It resulted in 84 possible solutions. Out of which 31 were ignored due to having very large energy sales back to the grid. The three optimum grid-connected system designs were selected based on the least values of COE and NPC, as shown in Table 1. Option 1 is the system with the least COE (0.0374 US\$/kWh), comprised of solar PV panels and an



electricity grid without a battery and converter. Since, the solar PV is connected to the grid with net metering or a smart meter option, the excess energy produced is directly sold back to the grid and during less or no generation of solar power, the energy is drawn from the grid. In a similar study in Dhaka, the COE was estimated to be 0.1 US\$/kW. Option 2 is another possibility with the least COE (0.0384 US\$/kWh) design where all the components; solar PV, grid, battery storage, and converter are used. Option 3 (0.085 US\$/kWh) is the base case without PV, i.e. 100% of the energy is purchased from the grid. This option 3 is presented for a comparison of economics and other relevant criteria.

Table 4: The optimization results

S.No	System Design				Cost (US\$)				Renewable Fraction	Energy Purchased	Energy Sold	IRR	Simple Payback
	PV (kW)	Li-ion battery	National Grid	Con cap. kW	NPC (Million)	COE (/kWh)	Initial Capital	Annual Bill savings	%	kWh	kWh	%	year
Option1	5,000	-	√	-	6.07	0.0374	7.49	849,839	69.2	3,870,604	5,069,842	10	8.9
Option2	4,974	119	√	6.28	6.20	0.0384	7.52	845,114	69.2	3,855,812	5,007,016	10	9.0
Option3	-	-	√	-	9.47	0.085	-	-	0	7,494,770	-	-	-

The COE of Option 1 is almost 62% less compared to the base case, i.e. 100% from the grid. This significant difference in COE could have been possible due to earnings from selling the energy back to the grid. In option 1, 69.2% of the total energy is produced by solar PV and almost 56.7% of this total energy is sold back to the grid. The capacity factor of the PV system at this location is found to be 19.8%. The annual utility bill saving is estimated to be around US\$ 850,000. The internal rate of return, IRR and simple payback period are 10% and 8.9 years which is considered a successful project. In a similar study in UAE with comparable weather conditions, the simple payback was estimated to be 13 years (Al Awadhi et al., 2019).

### Conclusions

An EV is most ideal in academic campuses as it increases awareness and usually, the traveling distances within the campus are limited. The techno-economic feasibility of charging EVs from the generated power is also carried out. Out of several feasible solutions, one with the least COE of 0.0374 US\$/kWh, which is about 62% lesser compared to the base case is recommended. This recommended system (Option 1) is comprised of 5,000 kW PV capacity and the national power grid. Since the solar PV is connected to the grid with the smart meter option, the excess energy produced is directly sold to the grid. The optimum option 2 which utilizes all the components, solar PV, grid, battery storage, and converter is found to have a COE of 0.0384 US\$/kWh. This option comprises of 4,974 kW of PV, 119 strings of li-ion battery, and 6.28 kW of converter capacity. The NPC for the two options is found to be US\$ 6.07 and 6.2 million respectively. In both options, almost 69.2% of the energy is produced from solar PV and almost 3.8 GWh of energy is purchased from the grid and 5 GWh is sold back to the grid. The annual utility bill savings are estimated as US\$ 850,000. The internal rate of return, IRR, and simple payback period are found to be 10% and 8.9 years for both options. The annual energy served for the charging of EV's is around 195 MWh i.e. about 1.5% of the total energy consumption from the optimum system. The daily average EV charging load is 578 kWh/day. The proposed model can be applied to academic institutes elsewhere having similar climatic conditions. Overall, it can be observed that the smart-grid with a net metering option will bring down the capital cost considerably. This study will lead to increased renewable energy penetration in the existing energy portfolio and will help in reducing reliance on fossil fuels for power generation. The feasibility of charging the electric vehicles from the power generated using renewable sources will be vital for future usage in green cities like NEOM.

### References

Baseer, M.A., Alqahtani, A., Rehman, S., 2019. Techno-economic design and evaluation of hybrid energy systems for residential communities: Case study of Jubail industrial city. *J. Clean. Prod.*, 237, 117806.

Baseer, M.A., Meyer, J.P., Alam, M.M., Rehman, S., 2015. Wind speed and power characteristics for Jubail industrial city, Saudi Arabia. *Renew. Sustain. Energy Rev.* 52, 1193-1204.

Baseer, M.A., Meyer, J.P., Rehman, S., Alam, M.M., 2017(a). Wind power characteristics of seven data collection sites in Jubail, Saudi Arabia using Weibull parameters. *Renew. Energy*, 102, 35-49.

Baseer, M. A., Rehman, S., Meyer, J.P., Alam, M.M., 2017(b). GIS-based site suitability analysis for wind farm development in Saudi Arabia. *Energy*, 141, 1166-1176.

Cloete, S., 2019. An independent Global Energy Forecast to 2050, to compare with the IEA's WEO 2019. [Energypost.au](http://Energypost.au).

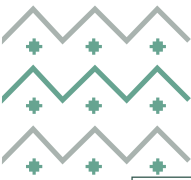
Felimban, A., Prieto, A., Knaack, U., Klein, T., Qaffas, Y., 2019. Assessment of current energy consumption in residential buildings in Jeddah, Saudi Arabia. *Buildings*. <https://doi.org/10.3390/buildings9070163>

General Authority of Statistics, Saudi Census, 2015. . Stat. Year.

IEA, 2020. Key energy statistics. ©IEA 2020. <https://www.iea.org/countries/saudi-arabia> (accessed 9.13.20).

Kingdom of Saudi Arabia, Saudi Vision 2030, 2016. National transformation program 2020. Saudi Vis. 2030.

Saudi Industrial Development Fund, SIDF, 2019. <https://www.sidf.gov.sa/en/Pages/default.aspx> (accessed 2.17.20).



## **Net Billing Tariff Assessment in the Kingdom of Saudi Arabia for a Feasible Integration of Distributed On-Grid Residential Roof-Tops Solar PV**

Abdul Hafiz Al Hariri, Mechanical Engineering Department, King Fahd University of Petroleum & Minerals, g202110370@Kfupm.edu.sa  
Fahad Al Sulaiman, Interdisciplinary Research Center for Renewable Energy and Power Systems & Center of Energy Efficiency KFUPM, fahadas@kfupm.edu.sa

Nasser Al Kaabi, Saudi Iron and Steel Company HADEED-SABIC Jubail, alkaabin@hadeed.sabic.com

Shafiq Rehman, Interdisciplinary Research Center for Renewable Energy and Power systems (IRC-REPS), KFUPM, srehan@kfupm.edu.sa

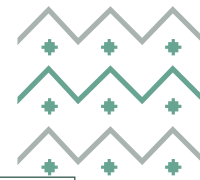
### **Overview**

The Saudi Arabian 2030 vision aims at accelerating the energy transition to achieve national sustainability in accordance with Saudi ambition of achieving net-zero emissions by 2060. Achieving sustainability requires investment in Renewable Energy Resources (RES) such as solar PV systems. Saudi Arabia is moving forward to achieve its sustainable vision, hence, authorities are investing in Mega-Scale solar PV Projects, such as the projects in the Red Sea coast and Neom. Furthermore, legislation is put to accelerate the integration of Distributed Solar PV panels as a priority for Saudi residents. For this reason, cooperation between the Saudi Electricity Company (SEC) and Water and Electricity Regulatory Authority (WERA), which was also referred to as Electricity & Cogeneration Regulatory Authority (ECRA), resulted in the Shamsi program to manage the installation of small capacity solar PV systems. The WERA framework is set to organize the sizing capacity, the pricing policy and the required legislation procedures for the installation of such residential roof-top solarsystems. In this work, a techno-economic analysis of the integration of solar photovoltaic (PV) systems based on the current energy valuation policies set by the authorities has been performed for private residential unit located near the touristic islands on the red seacoast between Ummluj and Al Wajh cities, the latitude and longitude of the chosen area are 25.34°N and 36.75°E respectively. The study found that it is not feasible to invest in an on-grid solar PV system based on the current pricing policies. Therefore, a new energy policy has been proposed, which is an increase in the imported and exported power tariff rates. The simulation results revealed that increasing the tariffs for peak load time (10 Am to 4 PM) makes the investment in an on-grid PV system feasible for an increased imported tariff of 0.092 \$/kWh for the selected location. The proposed policy aims and encourages the residents to invest in solar PV systems which will result in the reduction of carbon emissions by 2030. Additionally, it will help in managing and shaving the peak load demand which is a cost burden on any utility electric company. The current proposal has been assessed for different cities around the kingdom representing different climate zones. The hourly simulation is performed using HOMER software and the economic analysis is based on the Net Present Cost (NPC) and the Levelized Cost of Energy in USD/killowatt-Hour (COE in \$/kWh).

### **Methods**

In this research study, a solar PV system has been technically sized based on WERA regulations for a real electrical load that has been provided by the SEC. The studied residential unit has an average daily electrical consumption of 170 kWh and a peak of 16 KW in the summer resulting in a 32 KW solar system after taking into consideration the power generating factor, the derating factor, and the effect of the temperature on the efficiency. The research has been divided into two main parts. The first part consists of an economical assessment of the cost of energy based on the current pricing policies, for both grid-only and grid-connected solar PV. The second part consists of increasing the buy and sell-back tariffs for different cities in the Kingdom. For consistency, the analysis is based on the NPC (USD) and COE (\$/kWh). In both cases, an hourly simulation has been performed using Homer software based on an hourly basis. The solar PV has been designed to provide the electric load as per the WERA framework taking into consideration the Net-Billing policy, in which the value of the financial exported electricity to the grid could not exceed the financial value of the energy imported from the grid. After the technical design, the cost estimation and the mathematical model have been provided for an accurate simulation. The simulation Model has been built using the selected software, the technical and economic results have been extracted for the analysis of both actual and proposed scenarios. For generalization, the simulation has been performed for different energy costs and for different cities with different climate zones to achieve a policy that could be applied all around the kingdom. The strength of this study comes from achieving the same NPC for a resident implementing a solar PV equal to the NPC in the subsidized grid-only scenario. This result has been concluded when analyzing different policies, one is increasing the energy imported tariff from the grid to the residential unit and the second is when increasing the energy exported tariff from the solar system to the grid.





## Results

Technically, a total yearly of 62,050 KWh was purchased from the grid for the grid-only scenario. For the case of grid-connected solar PV, a reduction in the yearly energy purchased from the grid by 45% with a provision of 30,297 KWh additional energy exported to the grid resulting in an increase in the renewable energy share and a decrease in the energy required from the conventional power plants.

Economically, and based on the pricing policies set by WERA, it is found that for the grid for the grid-only scenario the NPC over a 25 years lifecycle is 68,481 USD and a Cost of Energy (COE) of 0.0531 \$/KWH for a total yearly of 62,050 KWh purchased from the grid. On the other hand, the economic results found an increase in the NPC by 31 % to a value of 90,258 USD than applying the current actual policy owing to the low subsidized electric cost in the Kingdom and to the reduced energy exported tariff that is applied, which makes investing in On-grid Solar PV still not an economic choice.

The proposed pricing policy, is an increase in the energy imported tariff in peak times (10 Am to 4 PM). It is found that for a value of 0.092 \$/kWh (the breakeven point in Figure 1 with the grid-only scenario for the increased tariff in peak time) could be a feasible solution with an NPC of around 92,200 \$ for the selected location when the energy exported tariff is still the same as policy (0.02 \$/kWh). This could be considered just an increase in the cost, for this reason increasing the energy exported tariff to 0.06 \$/kWh resulted in NPC decrease from 90,457 \$ to 69,271 \$, which is the same cost as the subsidized grid-only actual case.

The analysis in Figure 1 presents the minimum increased buy-tariff in peak loads for different Saudi cities. It is found that for higher solar intensity a lower increased tariff is required. It may be accounted for more electricity production from solar PV Panels, which makes the integration more feasible.

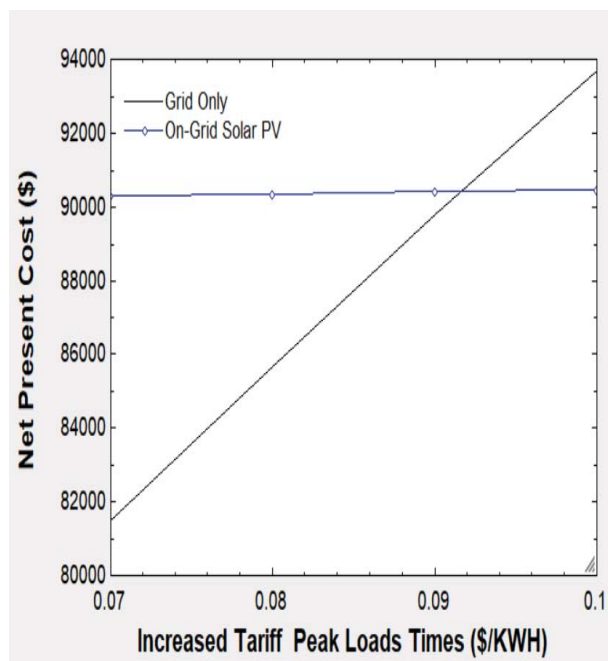


Figure 1 The Variation of NPC with respect to Different Values of Proposed Increased Tariffs in Peak Time for the Selected Location

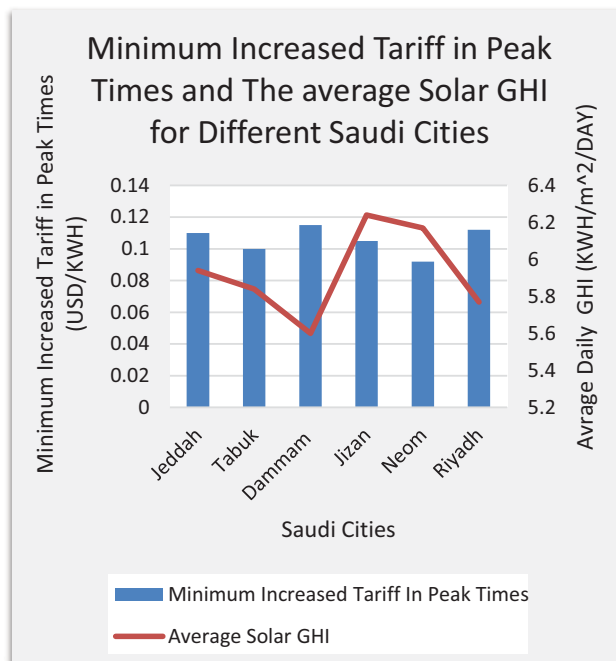
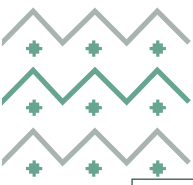


Figure 2 Minimum Increased Tariff for Different Saudi Cities

## Conclusions

The change in the energy imported and exported valuation during peak hours in the Kingdom of Saudi Arabia can change the game of the integrated solar PV market for residential applications. More importantly, the proposed policy shows that this can significantly help to shave the energy demand in peak hours which can lead to a reduction of SEC operation and maintenance costs. The Kingdom is investing in utility-scale projects but with just a small change in the peak tariff to 0.115 \$/kWh for the whole kingdom could encourage consumers to contribute to the Saudi Green Initiative by utilizing rooftops distributed solar PV power systems.





## ***Demand-Side Management and Economic Dispatch for Energy Transition in Karnataka, India***

Balasubramanian Sambasivam<sup>1,2</sup>, Yuan Xu<sup>1\*</sup>

<sup>1</sup> Department of Geography and Resource Management, The Chinese University of Hong Kong, Hong Kong, China; <sup>2</sup> Walker Department of Mechanical Engineering, The University of Texas at Austin, Austin, USA

### **Overview**

India has set 2070 as the target year to achieve carbon neutrality, while fossil fuels are dominating its energy system and the country's GDP per capita still significantly trails developed countries. The economically optimized energy transition towards renewables is crucial for India to reduce CO<sub>2</sub> emissions in an affordable manner. India has installed a large fleet of solar PV and thus, maximizing their capacity factors play an influential role in such energy transition.

Curtailement can be implemented due to technical and policy issues (Boddapati et al., 2021)). The technical reasons for renewable energy curtailement are constraints in transmission capacity, system balancing, excessive supply coupled with low demand, grid congestion, etc. (Bird et al., 2016; O'Shaughnessy et al., 2020). The lack of available transmission infrastructure is also a reason for curtailement. The policy-related issues for curtailement are tariff issues, changes in power purchase agreements, electricity dispatch rules, etc. Considering dispatch rules, if the utilities did not follow the least cost dispatch or renewable energy priority dispatch, curtailement is possible. Curtailement of net zero-emission solar PV and wind power is adverse to achieving carbon emission targets as it increases operational hours of conventional carbon emitter thermal power plants (Golden and Paulos, 2015).

This study examines how the state of Karnataka managed to substantially enhance the solar PV capacity factor from 2017 to 2019 by two-thirds. We built a mixed-integer linear programming (MILP) model with detailed hourly data to quantify the impacts of two major policy changes, shifting electricity supply to irrigation from nighttime to daytime (load shift) and dispatching electricity generation units by their merit order (economic dispatch). Our results indicate that these two measures could explain about one-fifth and three-quarters of the capacity factor increase, respectively, over the three years, which is equivalent to reducing the cost of solar electricity by about 40%. India and other countries may further expand these policies for accelerating and optimizing energy transition.

### **Methods**

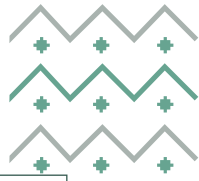
We present a mathematical model-based approach to reproduce the real-life scenario. The proposed mathematical model is a mixed-integer linear programming (MILP) model. The objective of the mathematical model is to meet the electricity supply and demand with two types of dispatch strategies, namely random dispatch, and economic dispatch. The random dispatch, and economic dispatch strategies mimic the real-life day ahead self-schedule market design and market-based economic dispatch strategies, respectively. Further, the model is used to study the combined impacts of the introduced demand-side management strategy (load shift) with the dispatch strategies. The economic dispatch (dispatch based on marginal cost) strategy aims to meet the electricity supply and demand by minimizing the cost of electricity supply. Load shift denotes the demand-side management strategy introduced in the electricity system. It signifies the shift of irrigation electricity demand to the daytime from night hours.

Regarding the constraints used in the mathematical model, no generation or operation limits are imposed on large hydro, mini hydro, solar, wind, biomass, and cogeneration power plants. Nuclear power plants are assumed to be base load power plants and will supply electricity throughout the day and all through the year. For thermal plants, ramp and generation limit constraints are imposed on their operation. The ramp-up and ramp-down limits are considered as 35% of the power plant's installed capacity. Further, the generation of thermal power plants should not exceed the maximum available potential. On the lower side, when the power plant is in operation, the generation from the plant should be at least 40% of its installed capacity. For thermal power plants, the model considers shut down costs and two types of startup costs (hot start and cold start). If the thermal power plant startup within five hours of its shut down, it is considered a hot start, and everything else is regarded as a cold start. For the ease of solving and for better convergence, the model is solved as a linear model. So, the startup and shut down costs are calculated outside the model. Electricity transmission and distribution costs are not considered in the model.

### **Results**

The validity of the impact of the policy change and load shift on solar PV capacity factors is evaluated. In January 2017, the installed capacity of solar PV was just 0.3 GW, and it increased to 1.6 GW by December 2017.





Correspondingly in January 2019, the installed capacity was 5.5 GW, and it rose to 6.6 GW by December 2019. Our research shows the two-week moving average of the solar PV capacity factors of economic and random dispatch with 2019 demand (with load shift) and without load shift. We can observe that with change in dispatch policy and without agricultural load shift, the consumption of solar PV was low, which can be understood from the low-capacity factors. Except during the second half of July and the beginning of August, the load shift has helped to elevate the capacity factors of solar PV in all the other periods. The likely reason for load shift not helping the increase in capacity factor during those days is that July and August are the peak monsoon months in Karnataka. During peak monsoon, the irrigation water demand is low, and there is a very high generation of wind power in the electricity system. From the two-week moving average of the solar PV capacity factors of economic and random dispatch with 2019 demand (without load shift) and with load shift, it can be observed that with the implementation of the policy change and load shift, the impact varies differently across the year, while with a random dispatch policy, the utilization of solar PV is low.

We present the impacts of load shift, economic dispatch, and greater installed capacity for the above discussed two sets of simulations. With random dispatch and without load shift in 2017, the total annual energy generated from solar PV is 1,053 GWh, which correlates to an annual capacity factor of just 12.1%. Further, with the increase in installed capacity and without load shift in 2019, the capacity factor of solar PV for random dispatch has increased by just 0.4% when compared to the similar scenario in 2017. This proves our assertion that with random dispatch the utilization of solar PV is low. In 2019 the total energy generated from solar PV with load shift and random dispatch is 7,551 GWh. Whereas without load shift and with random dispatch the total energy generated from solar PV in 2019 is 6,628 GWh. This shows that with random dispatch scenario the load shift was helpful in additional generation of 923 GWh in 2019 i.e., an increase of 1.9% more in capacity factor. This proves our second assertion that load shift is helpful to elevate the solar PV capacity factors. With random dispatch, the total electricity generated from solar PV in 2019 (actual demand, i.e., with load shift) is 7,551 GWh, whereas with economic dispatch, the total electricity generated is 10,852 GWh. With both load shift and economic dispatch in 2019, 3,301 GWh of more energy is generated from solar PV which is an increase of 6.1% in solar PV capacity factors. The electricity generated without load shift and with economic dispatch from solar PV in 2019 is 9,843 GWh and without load shift and with random dispatch is 6,628 GWh. Compared to with load shift and with economic dispatch policy for 2019, the electricity generated without agricultural load shift and with economic dispatch policy is 10% less which validates our hypothesis that the change in dispatch policy and agricultural load shift has helped in increasing the consumption of solar PV.

## Conclusions

This paper systematically establishes the causal relationship between dispatch policy and demand-side management (load shifts) on the capacity factor of solar PV power plants. With the random dispatch policy, the solar power in the system is underutilized. To mitigate this issue, a change to economic dispatch policy was introduced in the system. The capacity factor of solar PV technology has significantly increased with a corresponding reduction in the usage of thermal power. Further, implementing a demand-side management program, i.e., shifting the electricity supply to irrigation from night-time to daytime, has a significant impact on improving the utilization of solar power. The current research validates the hypothesis that solar PV curtailment has been reduced with the introduction of the new economic dispatch policy and irrigation load shift.

## References

- Bird, L., Lew, D., Milligan, M., Carlini, E.M., Estanqueiro, A., Flynn, D., Gomez-Lazaro, E., Holttinen, H., Menemenlis, N., Orths, A., Eriksen, P.B., Smith, J.C., Soder, L., Sorensen, P., Altiparmakis, A., Yasuda, Y., Miller, J., 2016. Wind and solar energy curtailment: A review of international experience. *Renew. Sustain. Energy Rev.* 65, 577–586.
- Boddapati, V., Nandikatti, A.S.R., Daniel, S.A., 2021. Techno-economic performance assessment and the effect of power evacuation curtailment of a 50 MWp grid-interactive solar power park. *Energy Sustain. Dev.* 62, 16–28.
- Golden, R., Paulos, B., 2015. Curtailment of Renewable Energy in California and Beyond. *Electr. J.* 28, 36–50.
- O’Shaughnessy, E., Cruce, J.R., Xu, K., 2020. Too much of a good thing? Global trends in the curtailment of solar PV. *Sol. Energy* 208, 1068–1077.







## ***IMPACT OF PV DISTRIBUTED GENERATION ON LOOP DISTRIBUTION NETWORK IN RIYADH CITY***

Mohammed Alruwaili, KSU-SASO, +966504217185, malruwaili1@gmail.com

### **Overview**

Nowadays, renewable energy resources are playing an important role in replacing traditional energy resources such as fossil fuels by integrating solar energy with conventional energy. Concerns about the environment led to intensive search for renewable energy source. The Rapid growth of distributed energy resources will have prompted increasing interest in integrated distributing network in Kingdom of Saudi Arabia next few years, especially after the adoption of new laws and regulations in this regard. Photovoltaic energy is one of the promising renewable energy sources that has grown rapidly worldwide in the past few years, and can be used to produce electrical energy through the photovoltaic process. The main objective of the research is to study the impact of PV in distribution network based on real data and details.

### **Methods**

In this research, site survey and computer simulation will be dealt with using the well-known computer program software ETAB to simulate the input of electrical distribution lines with other variable inputs such as the levels of solar radiation and the field study that represent the prevailing conditions and conditions in Diriah, Riyadh region, Saudi Arabia. In addition, the impact of adding distributed generation units (DGs) to the distribution network, including solar photovoltaic (PV), will be studied and assessed for the impact of adding different power capacities.

### **Results**

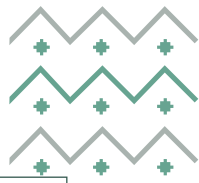
The result has been achieved with less power loss in loop distribution network from the current condition by more than 69% decrease in network power loss. However, the studied network contains 78 buses. It is hoped from this research to reduce power losses and enhance voltage profile of the distribution networks in Riyadh City. Simulation results prove that the applied method can illustrate the positive impact of PV in loop distribution generation.

### **Conclusions**

A comparative and deep comprehensive of real distribution network is introduced. The aim of this research is identifying the impact of PVDG on loop distribution network at Saudi Electricity Company substation in Diriah, Riyadh region, Saudi Arabia. An existing Substation and low voltage distribution network 132kV/13.8kV/400V belong Saudi Electricity Company was identified to be the case study. The ETAB software simulation program has been used to model, assess and analyze the applicable data and details from site survey or the accessible documents.

The efficiency, performance, quality and reliability were impacted differently with each case. An enhancement in power loss and voltage profile were investigated in five different cases. A comparative summary between the five cases was shown less power loss on loop distribution network from the current condition (Case I) and the best achieved case (Case V) with more than 69% an enhancement in the efficiency. Moreover, the voltage



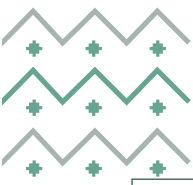


profile was enhanced with more flatten pattern over whole network with recorded Marginal under voltage more than 96.6%. The archived results design are becoming encouragement factors to be extensively practical and exploited in loop distribution network regardless other applicable factors.

## References

- [1] Hasan D, Serhat Y and Zehra N C (2019) "A Strategic Approach to Reduce Energy Imports of E7 Countries: Use of Renewable Energy" Handbook of research on economic and political implications of green trading and energy use. IGI Global, p. 18-38.
- [2] A Baras (2012) "Opportunities & Challenges of Solar Energy in Saudi Arabia" World Renewable Energy Forum, Denver. p. 4721
- [3] Ngaopitakkul, A., Pothisarn, C., Bunjongjit, S., Suechoey, B., Thammart, C. and Nawikavatan, A (2013) "A Reliability Impact and Assessment of Distributed Generation Integration to Distribution System". Energy and Power Engineering, 05(04), pp.1043-1047.
- [4] Al-Sefri, A. and Al-Shaalan, A (2019) "Availability, Performance and Reliability Evaluation for PV Distributed Generation". World Journal of Engineering and Technology, 07(03), pp.429-454.
- [5] A Eltamaly, M Al-Saud, A Abokhalil and H Farh (2019) "Photovoltaic maximum power point tracking under dynamic partial shading changes by novel adaptive particle swarm optimization strategy" Transactions of the Institute of Measurement and Control, 42.1: 104-115.
- [6] M Ghaffarianfar and A Hajizadeh (2018) "Voltage Stability of Low-Voltage Distribution Grid with High Penetration of Photovoltaic Power Units" Energies, 11(8), p.1960.
- [7] Alrumaih, M. and Al-Shaalan, A (2019) "Impact of PV Distributed Generation on Loop Distribution Network". Journal of Power and Energy Engineering, 07(08), pp.27-42.
- [8] Y Bakhuraisa1 ,A Al-Shaalan, M Abouelela, A Al-hasani (2020) "Common Mode Reduction of Transformer less Inverter for Grid Connected PV System" Test Engineering and Management 82:15230 - 15238
- [9] Z Haidar, A Al-Shaalan (2018) "Reliability Evaluation of Renewable Energy Share in Power Systems" Journal of Power and Energy Engineering, 6.9: 40-47
- [10] M Omar, A Taha, A Samak, M Keshek, E Gomaa, S Elsis, (2021) "Simulation and validation model of cooling greenhouse by solar energy (PV) integrated with painting its cover and its effect on the cucumber production" Renewable Energy, 172: 1154-1173
- [11] H Farh, A Al-Shaalan; A Eltamaly; A Al-Shamma (2020) "A Novel Crow Search Algorithm Auto-Drive PSO for Optimal Allocation and Sizing of Renewable Distributed Generation" IEEE Access, 8: 27807-27820.
- [12] H Ziar, P Manganiello, O Isabella, M Zeman (2020) "Photovoltaics: intelligent PV-based devices for energy and information applications" Energy & Environmental Science, 14.1: 106-126.
- [13] A Calcabrini, R Weegink, P Manganiello, M Zeman, O Isabella (2021) "Simulation study of the electrical yield of various PV module topologies in partially shaded urban scenarios" Solar Energy, 225: 726-733
- [14] A Rathore, N Patidar (2021) "Optimal sizing and allocation of renewable based distribution generation with gravity energy storage considering stochastic nature using particle swarm optimization in radial distribution network" Journal of Energy Storage, 35: 102282





## **Renewable resource rents, taxation and the effects of wind power on rural economies**

Russell Hillberry\*

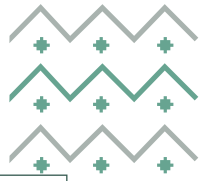
Nhu (Claire) Nguyen\*

March 28, 2022

**Abstract:** The rapid growth of utility-scale wind energy generation is a potentially important boon to rural economies in the United States. Yet econometric estimates suggest that the local economic benefits of wind energy generation have been modest, perhaps because the sector is capital-intensive and financed almost exclusively by external capital. In this paper we argue that a) both the presence of a critical - but unpaid - factor of production (the wind) and generous federal subsidies are quantitatively important sources of economic rent, and b) a large portion of these rents accrue to providers of capital who reside outside the local economy. We build a partial equilibrium model that illustrates the mechanisms that generate economic rent, and integrate it into a small open economy general equilibrium model of a county's economy. We calibrate the partial and general equilibrium models to data from two rural counties in Indiana, quantify the economic rents, and consider the consequences of a resource rent tax. Resource rent taxes generate significantly larger economic benefits for communities that host wind power, and offer an opportunity to spread the sector's economic benefits more broadly within them. Broadly distributed revenues from resource rent taxes might facilitate greater acceptance of utility scale wind power in communities where the sector would otherwise be unwelcome. State public utility commissions provide an analytical infrastructure that could support local taxation of the kind that we consider.

\*Department of Agricultural Economics, Purdue University, Krannert Building, 403 W State St. West Lafayette, IN 47907. Contact author is Hillberry. Tel: 1 (765)4944249. Email: rhillber@purdue.edu.





## Techno-Economic Study of Lighting Street and Residential Buildings Using Renewable Energy Resources: A Case Study of Riyadh City

[Megren Awad Alharthy, Al Baha University, +96653886999, engineer501@hotmail.com]  
[Ahmad F. Tazay, Al Baha University, +966568008345, eng.a.tazay@hotmail.com]

### Overview

Solar lighting and photovoltaic panels are recently used for residential and street lightings due to environmental, economic, and technical advantages. This manuscript aims to study and analyse building and street lighting systems regarding to technical and economic point of views. The research paper addresses the metrological data and installation regulations of several sites at Riyadh city at KSA. It also provides technical and economic analysis of a proposed system using Matlab/Simulink and HOMER software. The simulation results show that the proposed system using photovoltaic technologies can replace the traditional system for many reasons those are reduces dependency on fossil fuels, overcomes grid limitations, and decreases the overall system's cost. In addition to the many advantages of the solar lighting system; like zero harmful emissions, saving fossil fuels and zero operating cost.

### Methods

Metrological data were collected from KAPSARC and NASA during the years from 2003 to 2020 for the desired site. Then, the optimization techniques were used to find the lowest net present cost (NPC) and greenhouse emission CO<sub>2</sub>. HOMER software was used to apply the optimization algorithms to improve the economical and environmental aspects of the system. The dynamic analysis was also provided in the paper using Matlab/Simulink software.

### Results

The simulation results showed that implementing solar energy could improve the economic and environmental advantages for the proposed system comparing with the conventional system. The dynamic analysis showed that the proposed system could provide the required load demand. The optimization results using HOMER improved the economic and environmental fields by more than 30% comparing with the conventional lighting system.

### Conclusions

In conclusion, it is noticed that the solar powered LED street lighting proved to be economically feasible and saves fuel and money over its lifespan. Furthermore, the solar powered street lighting system is the optimum solution because the fuel consumption reduction which lead in reducing the CO<sub>2</sub> emission.

### References

- [1]. Ashraf Khalil, Zakariya Rajab, Moneer Amhammed, and Ali Asheibi, The Benefits of the Transition from Fossil Fuel to Solar Energy in Libya: A Street Lighting System Case Study, Applied Solar Energy, 2017, Vol. 53, No. 2, pp. 138–151. © Allerton Press, Inc., 2017.
- [2]. Mohammed Wadi, Abdulfetah Shobole, Mehmet Rida Tur and Mustafa Baysal, Smart Hybrid Wind-Solar Street Lighting System Fuzzy Based Approach: Case Study Istanbul-Turkey. 2018 6th International Istanbul Smart Grids and Cities Congress and Fair (ICSG), IEEE, 2018.
- [3]. Zakariya Rajab, Ashraf Khalil, Moneer Amhamed and Ali Asheibi, Economic Feasibility Of Solar Powered Street Lighting System In Libya, 2017 8th International Renewable Energy Congress (IREC), IEEE, 2017.
- [4]. TAZAY, Ahmad. Techno-economic feasibility analysis of a hybrid renewable energy supply options for university buildings in Saudi Arabia. Open Engineering, 2021, 11.1: 39-55.





## ***RENEWABLE DISTRIBUTED RESOURCES FOR OPTIMIZING THE TECHNO-ECONOMIC PERFORMANCE OF THE DISTRIBUTION NETWORKS VIA MGOA NATURE-INSPIRED OPTIMIZATION ALGORITHMS***

Ahmed S.Hassan, Ministry of Electricity and Renewable Energy - Egypt, +201115722379, eng.asami.moere@gmail.com.  
Araby M. Sayed, Ministry of Electricity and Renewable Energy - Egypt,  
ElSaeed A.Othman, Department of Electrical Engineering - Faculty of Engineering, Al-Azhar University - Egypt.  
Mohamed A.Ebrahim, Department of Electrical Engineering - Faculty of Engineering at Shoubra - Benha University - Egypt.

### **Overview**

The massive increase in the penetration of Distributed Generation (DG) units in traditional Electric Distribution Networks (EDNs) forces the distribution companies' operators to enhance the technical performance of EDNs while considering economic perspectives. This challenge paves the way for developing a multi-objective optimization platform to tackle the techno-economic problems while respecting system uncertainties as well as the operational policies of distribution companies.

Nature-inspired methodologies are particularly effective at addressing and solving the complex challenges in various areas of engineering, such as energy management systems, maximum power point tracking for both photovoltaic and wind energy systems, and parameter identification for renewable energy systems. These challenges are tackled by transforming them into optimization problems with complicated nonlinear constraints.

Many researchers have addressed the implementation of distributed generation resources within the distribution networks by introducing several techniques for enhancing their performance. However, it is noted that the past studies have been applied to a limited number of small-scale IEEE benchmark test systems and did not introduce large-scale or realistic case studies committed to real operating limitations. The DG units' operating power factor has been set as a fixed value and not a variable vector that needs to be optimized, and the weighting coefficient values of the fitness function have been selected randomly without a prior study. Several methodologies have successfully solved the DG optimization problem. However, these methods did not mitigate the optimal mix of the four DG units' types, and the DG units' maximum penetration capacity have not been determined regarding the branches' security constraints. In addition, the optimization of the required investment costs for the new DG unit's installation is set as an objective at the same time while enhancing the dynamic performance.

This paper attempts to address the above-mentioned issues of the previous researches. In addition, the current research has succeeded in (i) Employing Nature-Inspired algorithms for solving four different categories of distributed resources allocation and sizing problem. (ii) Presenting a new Improved Grasshopper Optimization Algorithm (IGOA). (iii) Constructing a new objective function to improve the voltage stability, reduce the active power losses and minimize the overall additional costs. (iv) Considering variable DGs' operating power factor as an optimization vector, in addition to some additional system's regulatory constraints, including (a) DG' penetration level, (b) DG' operating power factor and (c) system's voltage profile. (v) Validating the proposed approaches by applying them to various IEEE test systems (300 buses), and a real distribution system from the Egyptian grid to prove their effectiveness in solving different characteristics of complex systems.

### **Methods**

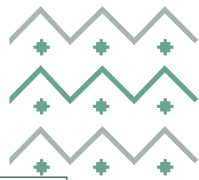
As a motivating solution for this multi-objective problem, this paper introduces the application of modern nature-inspired algorithm as multi-objective optimization technique for enhancing the techno-economic performance of EDNs through the integration of multiple types of Renewable Energy Resources. Grasshopper Optimization Algorithm (GOA) is inspired through these creatures complex social contact network that equips themselves with a specific predatory strategy. GOA has been employed and combined with Genetic Algorithms (GA) to develop Improved Grasshopper Optimization Algorithm (IGOA) for minimize the active power losses, enhance the Fast Voltage Stability Index, and reduce the total costs, considering the penetration level specified margin as well as the framework of the DG units' operating power factor constraints. The proposed algorithm has been integrated with Newton Raphson load flow equations under MATLAB environment and applied on various benchmark IEEE test systems 300-bus and a realistic part of the Egyptian distribution network (171-bus) is also introduced as a practical, applicable case study.



Renewables







## Results

Applying the modern proposed techniques to the distribution systems have demonstrated that the voltage stability is improved up to 36% and voltage levels enhanced up to 12% compared to base case, while these methodologies has corrected their voltage profile. whereas, the original cases failed in keeping voltage boundaries at all busbars. Furthermore, the active power losses are significantly reduced for the above-mentioned systems up to 26.5% compared to base case.

## Conclusions

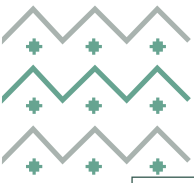
Results proved the effectiveness of the proposed optimization algorithm in addressing the multi-objective siting and sizing problem for the different types of renewable resources into complex distribution systems. However, Improved Grasshopper Optimization Algorithm proved its superiority in determining the best solution compared to others, in addition, it converges in minimum time and number of iterations.

## References

- [1] Maher, M., Ebrahim, M.A., Mohamed, E.A. and Mohamed, A., "Ant-lion optimizer based optimal allocation of distributed generators in radial distribution networks," *International Journal of Engineering and Information Systems*, vol. 1(7), pp.225-238, 2017.
- [2] Hussien, S.A. and Mahmoud, H., "Optimal placement and sizing of DGs in distribution system for improving voltage profile and reducing the power loss using moth flame optimization technique," *Int. J. Sci. Res. Eng. Technol*, vol. 6, pp.161-167, 2017.
- [3] S. Saremi, S. Mirjalili, and A. Lewis, "Grasshopper optimisation algorithm: theory and application," *Advances in Engineering Software*, Elsevier, vol. 105, pp. 30-47, 2017.
- [4] M. O. Okwu, & L. K. Tartibu, "Grasshopper Optimisation Algorithm (GOA). In *Metaheuristic Optimization: Nature-Inspired Algorithms Swarm and Computational Intelligence*," Theory and Applications, PP. 95-104, Springer, 2021.
- [5] O. Köksoy, and T. Yalcinoz, "Robust design using Pareto type optimization: a genetic algorithm with arithmetic crossover." *Computers & Industrial Engineering*, Vol. 55(1), pp.208-218, 2008.
- [6] Ewees, A. A., Al-qaness, M. A., Abualigah, L., Oliva, D., Algamal, Z. Y., Anter, A. M., ... & Abd Elaziz, M. (2021). Boosting arithmetic optimization algorithm with genetic algorithm operators for feature selection: case study on cox proportional hazards model. *Mathematics*, 9(18), 2321.
- [7] A. S.Hassan, , E. A. Othman, F. M.Bendary, & M. A. Ebrahim, "Optimal integration of distributed generation resources in active distribution networks for techno-economic benefits." *Energy Reports*, vol. (6), pp. 3462-3471. 2020.
- [8] M. Yahyazadeh, H. Rezaeeye, "Optimal Placement and Sizing of Distributed Generation Using Wale Optimization Algorithm Considering Voltage Stability and Voltage Profile Improvement, Power Loss and Investment Cost Reducing," *Iranian Journal of Science and Technology, Transactions of Electrical Engineering*, Springer, vol. 44(1), pp. 227-236, Mar 2020.
- [9] Hassan, A. S., Othman, E. A., Bendary, F. M., & Ebrahim, M. A. (2022). Improving the Techno-Economic Pattern for Distributed Generation-Based Distribution Networks via Nature-Inspired Optimization Algorithms. *Technology and Economics of Smart Grids and Sustainable Energy*, 7(1), 1-25.
- [10] Hassan, A. S., Adbelfattah, A. M., Othman, E., Bendary, F., & Ebrahim, M. A. (2021, September). Multi distributed generation categories integration into distribution networks via MMFO algorithm based on techno-economic benefits: a real Egyptian case study. In *CIREED 2021-The 26th International Conference and Exhibition on Electricity Distribution (Vol. 2021, pp. 1782-1786)*. IET.
- [11] V.R.N. Silva, and R. Kuiava, "Loading margin sensitivity in relation to the wind farm generation power factor for voltage preventive control," *Journal of Control, Automation and Electrical Systems*, Elsevier, Vol. 30(6), pp. 1041-1050, May 2019.
- [12] D. O. Ampofo, and I. K. Otchere, "An investigative study on penetration limits of distributed generation on distribution networks," 2017 *IEEE PES Power Africa*, IEEE, pp. 573-576, Jun 2017.
- [13] A. Hoke, R. Butler, J. Hambrick, et al., "Steady-state analysis of maximum photovoltaic penetration levels on typical distribution feeders," *IEEE Transactions on Sustainable Energy*, IEEE, Vol. 4(2), pp. 350-357, Nov 2012.
- [14] H. Saadat, "Power system analysis," McGraw-Hill, Boston, vol. (2), 1999.
- [15] R. D. Zimmerman, C. E. Murillo-Sánchez, et al., "Matpower: A MATLAB power system simulation package," *Power Systems Engineering Research Center*, Ithaca NY, 1997.
- [16] A. S.Hassan, , E. A. Othman, F. M.Bendary, & M. A. Ebrahim, "Distribution systems techno-economic performance optimization through renewable energy resources integration." *Array*, vol. (9), pp. 100050. 2021.
- [17] E.S. Ali, S.M.Abd Elazim , A.Y. Abdelaziz., "Ant Lion Optimization Algorithm for optimal location and sizing." *Renewable Energy*. Vol (101), pp. 1311-1324. 2017.





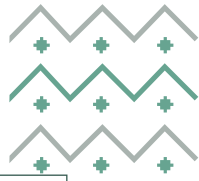


- [18] VC, V.R., "Optimal renewable resources placement in distribution networks by combined power loss index and Whale optimization algorithms." *Journal of Electrical Systems and Information Technology*. Vol 5(2), pp. 175-191. 2018.
- [19] C.H. Prasad., K. Subbaramaiah., P. Sujatha, "Cost-benefit analysis for optimal DG placement in distribution systems by using elephant herding optimization algorithm." *Renewables: Wind, Water, and Solar*. Vol 6(1). 201).
- [20] Shanmugapriyan, J., Karuppiah, N., Muthubalaji, S., Tamilselvi, S.: Optimum placement of multi type DG units for loss reduction in a radial distribution system considering the distributed generation. *Bulletin of the Polish Academy of Sciences: Technical Sciences*. 66(3). (2018).
- [21] Murthy, V.V.S.N., Kumar, A.: Comparison of optimal DG allocation methods in radial distribution systems based on sensitivity approaches. *International Journal of Electrical Power & Energy Systems*. 53, 450-467 (2013).
- [22] Devalalaji, K., Ravi, K.: Optimal size and siting of multiple DG and DSTATCOM in radial distribution system using bacterial foraging optimization algorithm. *Ain Shams Eng J*. 7:959-71 (2016).
- [23] Farh, H.M., Al-Shaalan, A.M., Eltamaly, A.M. and Al-Shamma'A, A.A.: A Novel Crow Search Algorithm Auto-Drive PSO for Optimal Allocation and Sizing of Renewable Distributed Generation. *IEEE Access*, 8, pp.27807-27820. (2020).



Renewables





## ***HOUSEHOLDS' WILLINGNESS TO ADOPT SOLAR ENERGY FOR BUSINESS USE IN UGANDA***

Jennifer Nabaweesi, Makerere University Business School, 256772870059, [jnabaweesi@mubs.ac.ug](mailto:jnabaweesi@mubs.ac.ug)  
Kabuye Frank, Makerere University Business School, 256785530322, [fkabuye@mubs.ac.ug](mailto:fkabuye@mubs.ac.ug)  
Muyiwa Samuel Adaramola, University of Life Sciences, Norway, +4797690282, [muyiwa.adaramola@nmbu.no](mailto:muyiwa.adaramola@nmbu.no)

### **Overview**

The adoption of solar energy by households is an important avenue of protecting the environment and enabling energy access in rural areas, especially in developing countries like Uganda where energy access is low. Therefore, this study investigates the factors that influence the households' willingness to adopt solar photovoltaic (PV) energy and how soon the households are willing to adopt solar PV energy for business use in Uganda.

### **Methods**

Unlike the previous studies, this study uses Heckman's two-step selection model, to analyze the two-stage process of willingness to adopt and how soon a household is willing to adopt solar PV energy for business use.

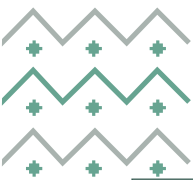
### **Results**

Results show that Sex, household head estimated income as it increases, mode of acquisition and repay months  $\leq 36$  are the only factors that positively influence both willingness to adopt and urgency to adopt solar energy for business use in households. Financial disclosure is significantly associated with willingness to adopt solar, while age and energy needs, were found to significantly influence how soon the household was willing to adopt solar PV energy for business use.

### **Conclusions**

The adoption of solar energy for business use is important in coping with environmental degradation and for enjoying reliable energy in a country like Uganda where the sun is abundant and in rural areas where the grid has not yet reached. The study is relevant for effective policy identification to promote the use of solar energy for business use in developing countries.





## EXTRACTIVES: CHALLENGES AND OPPORTUNITIES FOR THE SOUTH IN THE ENERGY TRANSITION

Adam Cohen<sup>1</sup> and Ricardo Raineri\*<sup>2</sup>

September 2, 2022

### Abstract

While the transition to a sustainable energy system will rely on a combination of additional deployment of existing technologies, deployment of new technologies, and development of innovative technologies, all will require an abundant, secure, and sustainable supply of minerals. The International Energy Agency noted that lithium, nickel, cobalt, manganese, and graphite are crucial to battery performance, longevity, and energy density. Rare earth elements are essential for permanent magnets for wind turbines and EV motors. Electricity networks need a considerable amount of copper and aluminum, with copper being a cornerstone for all electricity-related technologies. And iron and steel are critical for the renewal and improvements of infrastructure.

Countries with abundant mineral resources have a significant economic and workforce development opportunity as they contribute to the energy transition, the Paris Agreement's objectives, and the UN's Sustainable Development Goals. And at the same time, the challenge is to make mining and processing of extractives a sustainable industry that meets the growing demand for minerals with lower environmental impacts (lower emissions, lower water use, less waste).

Latin America is an important producer of critical minerals (copper, lithium, cobalt, and nickel), considering its current production levels and participation in the global reserves of copper, lithium, cobalt, and nickel.

Chile, Peru, and Mexico hold approximately 38% of the world's copper reserves, with additional reserves found in Argentina, Brazil, Colombia, and Ecuador. Approximately 60% of the world's identified lithium deposits are found in Latin America, mainly in Bolivia, Argentina, and Chile, and some in Mexico, Peru, and Brazil. Latin America also has significant nickel reserves, where Brazil hosts 17% of the world's nickel reserves and Cobalt in Mexico and in small quantities in Brazil.<sup>3</sup>

This paper analyses the challenges and opportunities that LAC, a region with abundant natural resources, will have in supporting a sustainable energy transition, a role that goes beyond enhancing its energy matrix, the one with the lowest levels of CO<sub>2</sub> emission, and is in its protagonist to sustainably deliver the critical minerals and cleaner fuels that the world needs to sustain the energy transition.

The presence of regionally abundant natural resources – both minerals and opportunities for expanded deployment of renewable energy (solar and wind) technologies for energy and clean fuels generation - can be a driver to transform the LAC into a Natural Laboratory for the innovation of clean technologies and improved processes, which in combination can make extractives more sustainable. Through the

---

\* Corresponding author, [rraineri@ing.puc.cl](mailto:rraineri@ing.puc.cl)

<sup>1</sup> President Associated Universities, Inc.

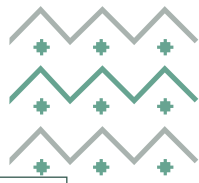
<sup>2</sup> Professor Pontificia Universidad Católica de Chile, and Advisor Associated Universities, Inc.

<sup>3</sup> USGS.



Renewables





deployment of innovative technologies and integration of workforce development efforts, the region can address the main challenges confronted by extractives in the region, including the conflict related to resource governance, the distribution of socioeconomic benefits, and the environmental impacts, CO2 emissions, waste and water use, consultation with affected communities. Examples of how some countries are confronting these issues are making extractives cleaner minerals sources to support the energy transition. Where, using science and the development of technologies, progress is made in giving greater added value to its natural resources, the country can climb in global supply chains and contribute to the objectives of the Paris Agreement and Sustainable Development of the UN.

## References

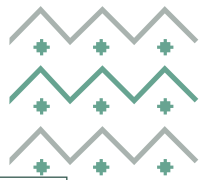
- International Energy Agency (2021). World Energy Outlook Special Report, "*The Role of Critical Minerals in Clean Energy Transition*".
- ANAC (2020). Automotive Market Report, December.
- Associated Universities, Inc. (2021). [www.aui.edu](http://www.aui.edu)
- Bipartisan Policy Center (2021). Webinar "*Critical Minerals are Key in the Energy Transition*", July 27, Washington DC USA <https://bipartisanpolicy.org/event/minerals-energy-transition/>
- Carolina Llanos (2020), Natural laboratories: comparative advantages for Chile. A challenge for diplomacy and science. <https://academiadiplomatica.cl/laboratorios-naturales-ventajas-comparativas-para-chile-un-desafio-para-la-diplomacia-y-la-ciencia/>
- Center for Climate and Energy Solutions (2021). revised <https://www.c2es.org/content/international-emissions/22/11/2021>
- Centro de Desarrollo Energético Antofagasta CDEA (2021). <https://www.cdeaua.cl/instalaciones/plataforma-solar-del-desierto-de-atacama-psda/>
- Mining Council (2021). Updated mining figures.
- Council for Science, Technology and Innovation between Chile and the United States (2019). "*Report first year of work*". <https://www.ecosisteam.cl/wp-content/uploads/2019/10/Informe-del-Consejo-CTI-Chile-Estados-Unidos-2019.pdf>
- Corfo (2021). Center for the Development of Electromobility. [https://www.corfo.cl/sites/cpp/convocatorias/centro\\_para\\_el\\_desarrollo\\_de\\_la\\_electromovilidad](https://www.corfo.cl/sites/cpp/convocatorias/centro_para_el_desarrollo_de_la_electromovilidad)
- Corfo (2021). Macrozona Norte Circular Economy Center. [https://www.corfo.cl/sites/cpp/convocatorias/centro\\_de\\_economia\\_circular\\_macro\\_zona\\_norte](https://www.corfo.cl/sites/cpp/convocatorias/centro_de_economia_circular_macro_zona_norte)
- Corfo (2021). Call for Clean Technologies Institute, RFP phase [https://www.corfo.cl/sites/cpp/convocatorias/instituto\\_de\\_tecnologias\\_limpias\\_fase\\_rfp](https://www.corfo.cl/sites/cpp/convocatorias/instituto_de_tecnologias_limpias_fase_rfp)
- Corfo (2021). [https://www.corfo.cl/sites/Satellite?c=C\\_NoticiaNacional&cid=1476727520687&d=Touch&page\\_name=CorfoPortalPublico%2FC\\_NoticiaNacional%2FcorfoDetalleNoticiaNacionalWeb](https://www.corfo.cl/sites/Satellite?c=C_NoticiaNacional&cid=1476727520687&d=Touch&page_name=CorfoPortalPublico%2FC_NoticiaNacional%2FcorfoDetalleNoticiaNacionalWeb)
- Chile's Fourth Biennial Update Report on Climate Change (2020), Ministry of the Environment – MMA -, Chile. [https://www4.unfccc.int/sites/SubmissionsStaging/NationalReports/Documents/574160\\_Chile-BUR4-1-Chile\\_4th%20BUR\\_2020.pdf](https://www4.unfccc.int/sites/SubmissionsStaging/NationalReports/Documents/574160_Chile-BUR4-1-Chile_4th%20BUR_2020.pdf)





- Dan Senor and Saul Singer (2011), "*Start-up Nation: The Story of Israel's Economic*". Council of Foreign Relations, Twelve Hachette Group Book, NY – USA
- Renewable Energies: The Journalism of Clean Energies (2021). Four consortia are proposed to develop the Chilean Institute of Clean Technologies <https://www.energias-renovables.com/panorama/cuatro-consorcios-se-proponen-para-desarrollar-el-20200403><https://www.energias-renovables.com/panorama/cuatro-consorcios-se-proponen-para-desarrollar-el-20200403>
- Renewable Energies: The Journalism of Clean Energies (2021). An American university consortium in which MIT participates is awarded the Institute of Clean Technologies. <https://www.energias-renovables.com/panorama/un-consorcio-universitario-estadounidense-del-que-participa-20210105>
- European Southern Observatory (2021). The Extremely Large Telescope. <https://elt.eso.org/>
- Explora Comisión Nacional de Investigación Científica y Tecnológica (CONICYT) (2020). Chile's leading role in international astronomy. <https://www.explora.cl/blog/el-rol-protagonico-de-chile-en-la-astronomia-internacional/>
- Felipe Larrain (2018). Natural laboratories for Chile, newspaper La Tercera. <https://www.latercera.com/pulso/noticia/laboratorios-naturales-chile/227792/>
- Global Data (2020). Global lithium demand to more than double by 2024, as electric vehicle battery production quadruples. <https://www.globaldata.com/global-lithium-demand-double-2024-electric-vehicle-battery-production-quadruples/>
- GMTO Corporation (2021). Giant Magellan Telescope. <https://www.gmto.org/>
- World Bank Group (2020). Climate Smart Mining Facility, "*Minerals for Climate Action: The Mineral Intensity of the Clean Energy Transition*".
- World Bank Group (2021). "*Potential solar energy by country*" <https://www.worldbank.org/en/topic/energy/publication/solar-photovoltaic-power-potential-by-country>
- World Bank Group (2021). Open Data. <https://data.oecd.org/rd/gross-domestic-spending-on-r-d.htm>
- World Bank Group (2021). Open Data. <https://data.worldbank.org/indicador/GB.XPD.RSDV.GD.ZS> hydroelectric from Arica to Chile, Santiago.
- [https://www.corfo.cl/sites/cpp/convocatorias/instituto\\_de\\_tecnologias\\_limpias\\_fase\\_rfp](https://www.corfo.cl/sites/cpp/convocatorias/instituto_de_tecnologias_limpias_fase_rfp)
- Hydrogen Council November (2017), "*A sustainable pathway for the global energy transition: Hydrogen scaling up*". <https://hydrogencouncil.com/wp-content/uploads/2017/11/Hydrogen-scaling-up-Hydrogen-Council.pdf>
- IDTechEx (2017). The Electric Vehicle Market and Copper Demand. <https://copperalliance.org/wp-content/uploads/2017/06/2017.06-E-Mobility-Factsheet-1.pdf>
- IEA (2020). "Energy Technology Perspectives 2020", Paris.
- IEA (2021). "Global EV Outlook 2021", Paris.
- IEA (2021). "The Role of Critical Minerals in Clean Energy Transitions", Paris. <https://www.iea.org/reports/the-role-of-critical-minerals-in-clean-energy-transitions>
- InvestChile (2021). Natural laboratory to test new technologies and sustainable businesses. <https://investchile.gob.cl/es/porquechile/tendencia/>

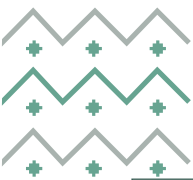




- José Miguel Aguilera R (2018). "*Laboratorios Naturales para Chile: Ciencia e innovación con ventaja*", ASIN: B07GNP22H9, Ediciones UC, Chile.
- Justin Miller and Lisa Viscidi (2016). "Innovation in Clean Energy in Latin America", Inter-American Dialogue and CAF - Development Bank of Latin America.  
<http://www.thedialogue.org/wp-content/uploads/2016/02/Innovaci%C3%B3n-en-energ%C3%ADa-limpia-en-Am%C3%A9rica-Latina-3.pdf>
- Lindsay Delevingne, Will Glazener, Liesbet Grégoir, and Kimberly Henderson (2020). "*Climate risk and decarbonization: What every mining CEO needs to know*". McKinsey Sustainability.  
<https://www.mckinsey.com/business-functions/sustainability/our-insights/climate-risk-and-decarbonization-what-every-mining-ceo-needs-to-know>
- Minerals Council of Australia and Commodity Insights (May 2021). "*Commodity Demand Outlook 2030*": <https://www.minerals.org.au/sites/default/files/Commodity%20Outlook%202030.pdf>
- Chilean Mining (2018.) <https://www.mch.cl/reportajes/los-detalles-del-acuerdo-corfo-sqm/#>
- Ministry of Energy of Chile (2017). National Electromobility Strategy.  
<https://energia.gob.cl/electromovilidad>
- Ministry of Energy of Chile (2020). National Green Hydrogen Strategy.  
[https://energia.gob.cl/sites/default/files/national\\_green\\_hydrogen\\_strategy\\_-\\_chile.pdf](https://energia.gob.cl/sites/default/files/national_green_hydrogen_strategy_-_chile.pdf)
- Ministry of Energy of Chile (2021). "*Solar Explorer Ministry of Energy Chile*":  
<https://solar.minenergia.cl/mediciones>
- Ministry of Energy of Chile (2021). Anuncio del cierre anticipado de plantas de generación de carbón. <https://energia.gob.cl/noticias/nacional/ministro-juan-carlos-jobet-tras-historico-anuncio-de-cierre-adelantado-de-centrales-carbon-este-nuevo-hito-nos-acerca-cada-vez-mas-hacer-de-chile-un-pais-de-energias-limpias>
- Ministry of Energy of Chile (2021). National Electromobility Strategy.  
<https://energia.gob.cl/electromovilidad>
- Ministry of Energy of Chile (2021). Law 21305 on Energy Efficiency.  
<https://www.bcn.cl/leychile/navegar?idNorma=1155887>
- Ministry of Energy of Chile / GIZ (2014). Renewable energies in Chile. The wind, solar and hydroelectric potential from Arica to Chile, Santiago.
- United Nations (2015). General Assembly resolution 70/1. Sustainable Development Goal.  
[https://www.un.org/ga/search/view\\_doc.asp?symbol=A/RES/70/1&Lang=E](https://www.un.org/ga/search/view_doc.asp?symbol=A/RES/70/1&Lang=E)
- United Nations (2020). General Assembly resolution 74/225.  
<https://undocs.org/en/A/RES/74/225>
- OLADE (2019). At cop25 10 countries in Latin America and the Caribbean are committed to contribute to reach 70 of renewable energy in the region. <http://extranet.olade.org/noticias/at-cop25-10-countries-in-latin-america-and-the-caribbean-are-committed-to-contribute-to-reach-70-of-renewable-energy-in-the-region/?lang=en>
- Mining Portal (2015) Plataforma Solar Desierto de Atacama inaugurates the first stage of the project.  
<http://www.portalminero.com/display/NOT/2015/08/19/Plataforma+Solar+Desierto+de+Atacama+inaugura+primera+etapa+del+proyecto>
- Senate of Chile (2020). Draft law establishing the Framework Law on Climate Change.  
[https://www.senado.cl/appsenado/templates/tramitacion/index.php?boletin\\_ini=13191-12](https://www.senado.cl/appsenado/templates/tramitacion/index.php?boletin_ini=13191-12)







- National Electric System SEN. (2021) , <http://energiaabierta.cl/visualizaciones/factor-de-emision-sic-sing/>
- USGS (2021). Lithium Statistics and Information.

**About the Authors:**

**Adam Cohen** is the President and C.E.O. of Associated Universities, Inc. (A.U.I.). Before joining A.U.I. in 2017, Dr. Cohen was finishing his term at Princeton University. Until May 2017, he served as the Deputy Under Secretary for Science and Energy at the U.S. Department of Energy (D.O.E.), overseeing basic science, applied energy research, technology development, and deployment efforts, including the stewardship of 13 of the 17 D.O.E. National Laboratories.

His experience also includes nearly seven years as Deputy Director for Operations at the Princeton Plasma Physics Lab, and 18 years at Argonne National Laboratory, where he held several positions, including Deputy Associate Director for Energy Sciences and Engineering, and Deputy Director/Chief Operations Officer. He has served as head of the U.S. Delegation on the ITER Council, on the New Jersey Department of Environmental Protections' Oyster Creek Oversight Panel, and on the D.O.E. Laboratory Operations Board. Earlier in his career, he spent four years in the U.S. Navy as a submarine officer, and he worked at Babcock & Wilcox manufacturing nuclear fuel for research reactors.

Dr. Cohen is a Senior Associate with the Center for Strategic and International Studies Energy and National Security Program.

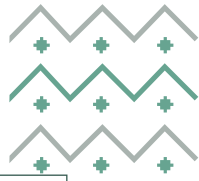
He earned his bachelor's degree in materials engineering from Columbia University, his M.B.A. from the University of Chicago, and his Ph.D. in materials science and engineering from Northwestern University.

**Ricardo Raineri**, Past President International Association for Energy Economics, former Chilean Energy Minister, and Chairman of the Board of de Chilean State Oil Company (ENAP), former Alternative Executive Director of the World Bank Group, Professor Pontificia Universidad Católica de Chile, Economic Advisor at Associated Universities, Inc., and President Global Mining and Energy Partners LLC.

Economist with vast professional experience in the energy sector and institutional issues on the economics of regulation and antitrust policy, market structure, pricing, business strategy and competition, and corporate governance. Has published in various academic and professional journals and regularly consults for the public sector and private companies.

He has a bachelor's in economics, a business engineer professional degree, a master's in economics degree from the Pontificia Universidad Católica de Chile, and a Master of Arts (M.A.) and Doctor of Philosophy (Ph.D.) both in Economics from the University of Minnesota. Member of the Editorial Board of The Energy Journal.





## MODELING, SIMULATION AND EXPERIMENTAL VALIDATION OF A MEMBRANE DISTILLATION UNIT SOLAR PART

[Khaled alserhan, Department of Mechanical, College of Engineering, University of Bisha, Bisha 61922, P.O. Box 199, Saudi Arabia, Alserhank@gmail.com]

[S. Mejbri, bLaboratory of Electromechanical Systems (LASEM), National Engineering School of Sfax, University of Sfax, 3038 Sfax, Tunisia, sami.mejbri@stud.enis.tn]

[M. M. Alquraish, Department of Mechanical, College of Engineering, University of Bisha, Bisha 61922, P.O. Box 199, Saudi Arabia, malqraish@ub.edu.sa]

[K. Zhani, Department of Mechanical, College of Engineering, University of Bisha, Bisha 61922, P.O. Box 199, Saudi Arabia, Kzhani@ub.edu.sa]

### Overview

Membrane distillation (MD) is a water purification method which uses thermal energy to produce freshwater from otherwise impure water such as seawater, industrial wastewater etc. In the solar MD process, heat generated by solar collector is applied to a flowing feedwater stream to generate water vapour. This water vapour then passes through a hydrophobic membrane which doesn't permit liquid water molecules to pass through but only volatiles, chiefly water vapour, to penetrate the membrane. On the other side of the membrane the vapour emerges and eventually forms the permeate/distillate. The present paper deals with modeling and experimental validation of the MD solar part. To numerically simulate the solar part, we have developed dynamic mathematical models of the solar collector. The resulting distributed parametric systems of equations are transformed into a system of ordinary differential equations (ODEs) using the orthogonal collocation method (OCM). Data from experiments and numerical were compared. It was discovered that the two-temperature mathematical model describes the real behavior of the solar collector more accurately than the one-temperature mathematical model. It was also demonstrated that the established mathematical model is capable of precisely predicting the trends of the thermal characteristics of the solar collector. As a result, the suggested models can be used to size and test the behavior of this kind of solar collector.

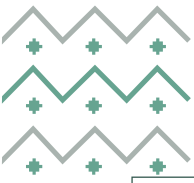
### Methods

To numerically simulate the solar part, we have developed dynamic mathematical models of the solar collector. The resulting distributed parametric systems of equations are transformed into a system of ordinary differential equations (ODEs) using the orthogonal collocation method (OCM). To validate the developed mathematical model, we have conducted a series of measurements on the following experimental setup:



Fig 1. the "MD ORYX" autonomous desalination solar-driven membrane distillation





## Results

The Figure below illustrating the water temperature at the outlet of the solar water collector calculated numerically by the two mathematical models as well as experimentally, shows that the temperature given by the two-temperature model is in good agreement with that measured experimentally. Therefore, the two-temperature model will be used to compare the experimental and theoretical values of the temperature at the four internal collocation points and at the outlet.

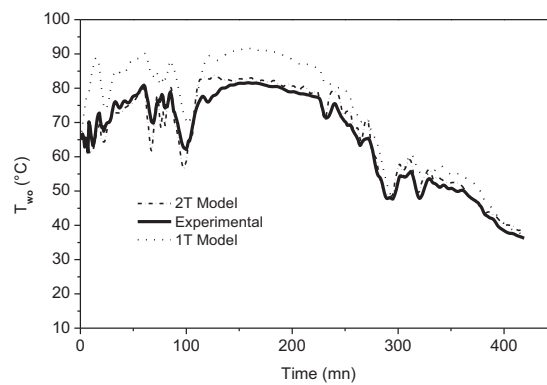
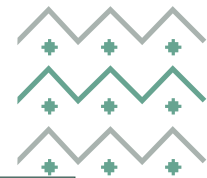


Fig.2. Comparison between experimental, predicted outlet temperatures with one and two-temperature models.

## Conclusions

The water solar collector utilized in the MD solar desalination unit IS modeled and experimentally validated in this research. We have created dynamic mathematical models explaining the behavior of the solar collector in order to numerically simulate the solar collector. The suggested mathematical models can be utilized to accurately forecast the thermal performance of solar collectors under a variety of weather situations and entrance parameter modifications. The results of the experimental validation showed that there was a good match between the numerical predictions of the temperatures at the intake, outlet, and collocation sites of solar collector and the practical values obtained by using sensors mounted on the solar collectors. This demonstrates both the accuracy of the mathematical models developed for solar collectors and the correctness of the OCM.





## [CAN HYBRID SOLAR PROJECTS PAVE THE WAY FOR CSP DEVELOPMENT]

[Ahmed Albalawi, KAPSARC, +966509716252, Ahmed.balawi@kapsarc.org]

### Overview

Hybrid renewable energy systems are a combination of two or more technologies that complement each other to result in clean and more stable power output. They offer flexibility and dispatchability. Hybrid systems, especially the combination of concentrated solar power and photovoltaic systems (CSP-PV), have been investigated for many years to try and address the challenges the electricity system faces with high penetration of renewables. A hybrid system with CSP-PV could provide a baseload generation well into the night hours. Recently, China's rapid renewable energy development through their "base projects" initiatives has paved the way for the development and deployment of many technologies including CSP-PV hybrids. The CSP technology featured in several winning tenders to be part of a large hybrid complex, typically collocated with 9-times larger PV system to cover peak demand more reliably. This study reviews the progress of CSP technology worldwide and explore how the hybrid renewable energy projects could pave the way for accelerated development of CSP.

### Methods

We examine the status of CSP projects through a dataset maintained and updated annually by CSP Guru (<https://csp.guru>). The database present information on 124 operational and under construction projects of CSP technologies worldwide. CSP deployment has been characterised by separate phases of policy incentives in different countries. Recently, the technological and financial development is driven by China's hybrid renewable energy projects that look to add 1 GW of CSP capacity to the grid. We review and analyse the recent advancement of CSP as part of a hybrid solar projects and extrapolate how these projects will accelerate the learning curve especially in terms of levelized cost of energy. We then assess the cost competitiveness of the technology to try and examine at which point will its levelized cost of electricity (LCOE) makes it competitive in the market as a standalone system. Similarly, we assess the future market of hybrid solar projects.

### Results

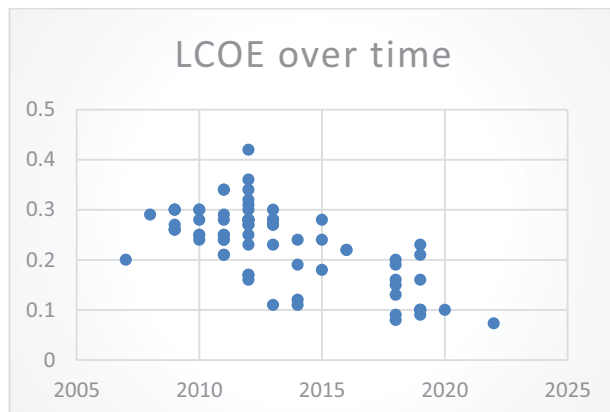
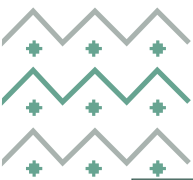
There is a growing trend of deploying CSP co-located with PV as a hybrid renewable energy project since CSP technologies have the energy storage inherent in the system, which makes them a flexible and dispatchable source of renewable energy. Some recent examples of the CSP-PV hybrid include the Noor Energy 1 project in Mohammed Bin Rashid Al Maktoum Solar Park, Dubai. The project includes a 700 MW CSP (100MW Tower and 3x200 MW parabolic trough systems) + 250 PV system. The development is led by ACWA Power and is following the example of the Noor project in Morocco by having CSP and PV co-located in a single site.

Recently, China's rapid renewable energy development through their "base projects" initiatives has paved the way for the development and deployment of many technologies including CSP-PV hybrids. The CSP technology featured in several winning tenders to be part of a large hybrid complex, typically a 100 MW CSP component as part of a GW system. The move towards hybrid renewable energy projects comes to address the challenges associated with the integration of new energy resources while maintaining power system stability and reliability.

Hybrid energy projects aim to combine the characteristics of different technology in a way that provides smooth output and reliable power that covers the daily fluctuations in demand including peak demand. This would give the hybrid renewable energy projects a big advantage and better financing prospects. The Chinese demonstration initiative hope to build their experience in this field in order to position themselves well for the international market. The key aspect to demonstrate is the reliability of the energy management system of these hybrid solutions to provide peaking power. CSP is viewed as one of the promising solutions in these configurations.

In terms of the LCOE, it has been decreasing at reasonable rate from an average of 0.27 \$/kWh in 2012 to an average of 0.15 \$/kWh in 2019. The costs are being driven to below 0.1 \$/kWh range by the recent developments in China and UAE.





## Conclusions

The increased deployment of intermittent resources brings into attention the importance of regulation the power during peak demand. Storage solutions, especially batteries, are all solutions that are being investigated and each has its own advantages and shortcomings. As for the CSP, it is a technology that brings the renewable energy capacity along with the benefits of flexibility and controllability that storage solutions offer. With the right level of operational experience and cost reductions, the technology can become financially competitive.

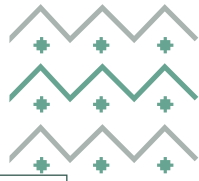
The cost of finance is a crucial element of the systems costs. Although CSP technology is not complicated, the system complexity arises from performance management of distinct different components that are usually manufactured and supplied by different specialized companies. In addition, the different type of CSP technologies and different applications makes it challenging for developers to identify the “winning” technology.

Currently, no active support mechanism is available for CSP developers, which creates a challenge to grow the market and continue innovations in the field. The recent incentivized large-scale projects were mostly in China with high localization focus under the incentive scheme that expired by the end of 2021. The accumulated expertise of developers from Europe and elsewhere are at risk of losing their advantage. The cost reductions of the technology may not be enough in its own to drive the industry forward. The hope for CSP industry is that the new hybrid model will unlock a new wave of projects for CSP that will help to accelerate the development and cost reductions. A new wave of CSP projects can continue to drive the costs down to around 0.05 \$/kWh by 2026 at the current learning rate, at which point the technology is expected to be cost competitive with other generation resources.

## References

All information, data and previous conclusions reflected in this paper will be sufficiently referenced.





## DESIGN SOLAR POWER SYSTEM FOR FISH FARM

Mutlaq Maktaf Albogame, AL- Baha University, 00966597558880, [442020513@stu.bu.edu.sa](mailto:442020513@stu.bu.edu.sa)

Zuhair Ahmed S.Alqami, Al-Baha University, 00966551280668, [zalgami@bu.edu.sa](mailto:zalgami@bu.edu.sa)

### Abstract

The fisheries industry is a vital contributor to the overall development of the country since it generates employment opportunities, broadens the range of livelihoods available, ensures adequate supplies of animal protein, and brings in foreign cash. This article examines the significance of the Kingdom of Saudi Arabia's vast fishing resources before concluding. The clarification was provided on the subject of using solar energy systems for the electric feeding of fish tanks. The solar power plant is a large-scale photovoltaic (PV) facility that was built to create bulk electrical power from solar radiation. It is also known as the photovoltaic (PV) power plant. Putting solar photovoltaic panels in place allows for the direct conversion of solar energy into usable electricity. The purpose of this research is to investigate, investigate, and develop a solar power system for fisheries to choose an appropriate location for the fishery-solar system. In the scorching months of summer, the solar power station can efficiently lower the water temperature, therefore preventing the spread of aquaculture illnesses and adjusting the metabolic rate of fish in such a way that they would develop more swiftly. The solar modules can cast a shadow over the water's surface, which shields it from direct sunlight. This reduces the number of algae that grows in the reservoir, which in turn boosts the water's quality and creates more favorable habitat for freshwater species. The electricity produced by the photovoltaic power station that is floating will be 10% greater than that which is generated by the photovoltaic power station that is located on land. Aerators, water pumps, and other pieces of equipment in the fish pond are all able to get electricity from the solar power system at the same time. It is also possible to sell any extra power to the local utility provider. The solar power system has the potential to lessen the amount of water that is lost due to surface evaporation. Solar applications will, in addition, minimize the amount of energy needed to run Fish Farm.





## **Renewable Energy and Job Creation: An Automation Risk Assessment**

[Cian Mulligan, KAPSARC, +966 1 290 3145, [cian.mulligan@kapsarc.org](mailto:cian.mulligan@kapsarc.org)]

### **Overview**

A major expected benefit of increased investment in renewable energy is mass job creation. The International Renewable Energy Association (IRENA) has been tracking job growth in renewables, showing year-on-year increases throughout the decade. The topic of "Green Jobs" – jobs created as a result of the energy transition – has been a popular research topic in labour economics also, and is seen as a core tenet of the Future of Work. However, closer inspection of the jobs that will be created as a result of renewable energy development in particular reveals some caution is necessary. Of the jobs that will be created, many are one-off in the development and construction phase of solar and wind energy installations. While a sufficiently diverse portfolio of rolling projects may keep workers busy throughout the year, a bigger issue lies in the threat of another aspect of the Future of Work: automation. The majority of jobs created -in manufacturing in the early phases, and in maintenance and operation in the main phase – involve tasks that have the potential to be automated in the near term. In countries that are hoping for "green jobs" to solve domestic unemployment problems, many are still in the early stages of planning their renewable projects, and therefore an opportunity exists in this stage to target specific areas of the renewables value chain to localise and in which to concentrate human capital development. This report analyses these value chains – in Solar PV, onshore wind and offshore wind projects - and approximates the automation risk for each task at each stage of the life cycle of the project, and gives policy advice on which areas should be focused on in order to futureproof their workers against automation and better prepare themselves for the labour market of the future.

### **Methods**

The paper will use IRENA data on employment potential in the solar PV, onshore wind and offshore wind value chains, and attach automation risk weights (from European Centre for the Development of Vocational Training CEDEFOP) to each job at each phase. In this way, we can project not only how many jobs are at risk of automation in each different renewable technology, but also at each phase of the project life cycle.

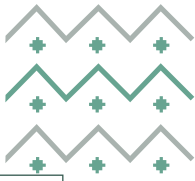
### **Results**

Early analysis implies permanent jobs created during the manufacturing phase are most at risk. Of the permanent jobs that will be created across the life cycle of the projects, a significant share of operations and maintenance tasks can be automated with the use of remote monitoring and drone surveillance. However, there is scope for full-time physical maintenance by workers. Overall, there is much lower risk of automation for the professional support services surrounding the projects, such as in legal support, policy and regulation advice and project planning.

### **Conclusions**

The analysis points to the need to carefully tailor localisation policies to target certain areas of the renewables value chain, rather than simply maximising job creation. While the manufacturing phase of solar and wind do yield the most jobs, these jobs comprise of tasks that are set to be automated in the near future, implying that the jobs created are not sustainable in the medium-long term. Further, the training of workers to do these jobs would be a bad human capital investment, and a more futureproof national human development strategy is needed in order to prepare workers adequately for the labour market of the future. In particular, an education system that prioritises skills with low risk of medium term automation is needed at the secondary, vocational and third levels.





## **CRITICAL MINERALS IN THE 8<sup>TH</sup> APEC ENERGY DEMAND AND SUPPLY OUTLOOK: A POST HOC ANALYSIS**

Mathew Horne  
Senior Researcher, APERC  
+81 80 8855 1863  
mathew.horne@aperc.or.jp

### **Overview**

Critical minerals will be an essential component of the coming energy transition. There are important considerations through the entire critical minerals supply chain for any energy transition to proceed effectively.

For the 8<sup>th</sup> edition of the *APEC Energy Demand and Supply Outlook* (8<sup>th</sup> Outlook), the Asia Pacific Energy Research Centre has constructed two potential energy futures out to 2050. The Reference scenario analyses recent trends in APEC energy consumption, production, and trade, to deliver one potential energy future. The Carbon Neutrality scenario explores additional energy sector transformations such as increased renewable generation, behavioural changes, fuel switching, and CCS deployment to meet elevated decarbonisation ambitions.

Both scenarios involve a large ramp-up in renewable generation capacity, and a large uptake in battery technologies for electric vehicles and grid storage. An accompanying ramp-up in critical minerals mining and processing will facilitate these future energy scenarios for the 21 APEC economies.

The modelled results for the two 8<sup>th</sup> Outlook scenarios incorporate increases in mining production and energy use that is associated with critical minerals. However, a detailed estimate of the magnitude of increase in critical minerals supply needed to fulfil the demand for these minerals for renewable capacity, batteries, and other technologies is currently unavailable. This paper will undertake a *post hoc* analysis of the increase in supply of minerals needed (including mining and processing) for the increase in energy transition technologies for both 8<sup>th</sup> Outlook scenarios.

### **Methods**

The starting point for this analysis will be the results delivered for the forthcoming 8<sup>th</sup> Outlook. These results include the build out of renewable capacity, the stock of electric vehicles (and other transport modalities that are reliant on critical minerals), capacity additions for grid level storage, and the increase in other technologies that rely on critical minerals, such as hydrogen production technologies, and advanced, more efficient, fossil fuel-based technologies.

A literature review will identify the type and quantity of important critical minerals that will be needed for the technologies listed above, including how the need for these inputs is likely to evolve through to the end of the projection period.

These two results, namely i) magnitude of critical minerals dependent technologies and ii) critical minerals needed at a granular/unit level, will provide an estimate of the increase in critical minerals supply needed for the two 8<sup>th</sup> Outlook scenarios out to 2050.

### **Results**

For the Reference scenario, solar capacity increases seven-fold to over 2 100 gigawatts (GW) in 2050 for the APEC region. Wind capacity increase four-fold to more than 1 300 GW. Battery storage capacity also increases significantly to more than 20 GW by 2050.

The Carbon Neutrality scenario involves a 12-fold increase in solar, to over 4 000 GW, and seven-fold increase in wind, to almost 2 200 GW. Battery storage capacity is more than six-times higher than the Reference scenario in 2050, reaching more than 130 GW.

The results for renewable capacity increases include shares of solar photovoltaics (utility and residential), concentrated solar power, and offshore and onshore wind. The shares of these types of renewable capacity have implications for the type of critical minerals that will be needed, and this will be incorporated in the analysis.





Outside of the power sector, electricity consumption within the transport sector increases six-fold out to 2050 in the Reference scenario and by more than 14-fold in the Carbon Neutrality scenario. The bulk of this growth in electricity is due to a significant increase in electric vehicles, which will involve a large increase in demand for critical minerals for the batteries that power them. There will also be significant growth in the charging networks required to support this level of penetration of electric vehicles.

Both the Reference and Carbon Neutrality scenarios involve an increase in green hydrogen production as well. This production was modelled separately from the electricity demand from all other demand sectors, given that the future for hydrogen is still uncertain. The green hydrogen production nevertheless implies a significant increase in renewable capacity. For the Reference scenario, more than 1 800 petajoules (PJ) of hydrogen is produced from electrolysis powered by renewable generation. In the Carbon Neutrality scenario, this green hydrogen production is almost four-times higher, reaching over 6 600 PJ by 2050.

Overall APEC electricity generation increases by 45% in the Reference scenario and by 60% in the Carbon Neutrality scenario out to 2050 (exclusive of green hydrogen electrolysis). Other low carbon generation, such as from bioenergy, geothermal, hydro, and nuclear, all increase in both scenarios and will lead to an increase in the demand for certain types of critical minerals as well. The increasing size of electricity networks delivering the increased quantities of electricity will also rely on a greater supply of critical minerals.

While there will be significant growth in demand for critical minerals from energy transition related technologies, there are some results from the 8<sup>th</sup> Outlook which imply a softening in demand for critical minerals. For instance, China's domestic property and construction sector contracts significantly out to 2050. This contraction will free up critical minerals, such as copper, for consumption outside of the property and construction sector.

## Conclusions

The Reference and Carbon Neutrality scenarios in the 8<sup>th</sup> Outlook present plausible energy futures for the APEC region out to 2050. However, the implied need for a significant increase in critical minerals supply, which includes an increase in mining activity and increase in minerals processing has yet to be conducted. For the high decarbonisation ambitions of the Carbon Neutrality scenario, ensuring critical minerals supply is available in sufficient quantities and at a competitive price will be crucial.

This paper provides a *post hoc* analysis of the critical minerals needed for these plausible energy futures to take place. In an overall energy system context, critical minerals dependent energy transition technologies are still at relatively low levels. This has meant that increasing economies of scale have been a driving force in making these technologies more competitive. However, with increasing uptake, there are challenges to ensuring whether there will be sufficient sources of supply to enable a widescale rollout of these technologies. Supply challenges will need to be overcome, if critical mineral are to become as prominent as many institutions, including APERC, are projecting.

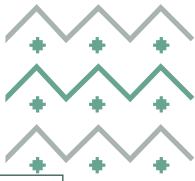
## References

Asia Pacific Energy Research Centre (2022), APEC Energy Demand and Supply Outlook 8th Edition [scheduled to be published in September 2022]

Carrara S. et al. (2020), Raw materials demand for wind and solar PV technologies in the transition towards a decarbonised energy system, European Commission Joint Research Centre (JRC), <http://dx.doi.org/10.2760/160859%20>

Giurco, D. et al. (2019). Requirements for minerals and metals for 100% renewable scenarios, In: Teske S. (eds) Achieving the Paris Climate Agreement Goals, [https://doi.org/10.1007/978-3-030-05843-2\\_11](https://doi.org/10.1007/978-3-030-05843-2_11)





## IS SMALL POWERFUL? AN EVALUATION OF THE ECOLOGICAL, ECONOMIC, AND SOCIAL ASPECTS OF THE DECENTRALIZED ENERGY TRANSFORMATION

Jens Weibezahn, Copenhagen Business School, jew.eco@cbs.dk  
Raluca Dumitrescu, Technische Universität Berlin, raluca.dumitrescu@microenergy-systems.de  
Daniel Philipp, Technische Universität Berlin, daniel.philipp@microenergy-systems.de

### Overview

The energy sector as a main contributor to greenhouse gas emissions needs to undergo a large and rather quick transition in order to adjust for the Paris Agreement and to limit global warming to 1.5 or at least two degrees. Moving from conventional to renewable energy generation might also shift the place of installation, especially for small-scale end-users (i.e. citizens). We recognize that the current regulatory set-up in Europe results in large distributional effects of costs: high income households are more likely to own properties and therefore generation technologies while low-income households co-finance the installations and the system via taxes, levies and fees, leading to an increase in their costs (Borenstein and Davis 2016; Lüth, Weibezahn, and Zepter 2020). However, there is large potential to install generation technologies at smaller capacities, but the latest development has shown that more emphasis is put on the development of large-scale renewable energy installations, i.e. onshore and offshore wind farms or open-space PV (BMW 2019). In an urban context, there is a limitation of space for high-capacity installations, yet high, centralized electricity demand.

However, decentralized residential and small-scale technologies that combine generation and storage in the vicinity of the end-user in one location have not been regarded as one of the main influential parts of the transformation to sustainable energy. On the one hand, we find studies that emphasize the potential of residential and urban renewable energy technologies (Fraunhofer ISE 2020), but also see reports, on the other, that present the downsides of the approach to roll-out small-scale technology (Mathiesen et al. 2017). Considering rooftop PV, some studies show that costs for the technology, installation, and maintenance are much higher than for PV parks (Fraunhofer ISE 2018). Arguing based on pure system costs, we see a limitation in the approach (acatech, Akademiunion, and Leopoldina 2020) and formulate the hypothesis that decentralized generation in an urban high demand area is equally important for a successful energy transition as the large-scale deployment onshore and offshore. This follows earlier, established theories of decentralization (Schumacher 1973; Weizsäcker, Lovins, and Lovins 1997).

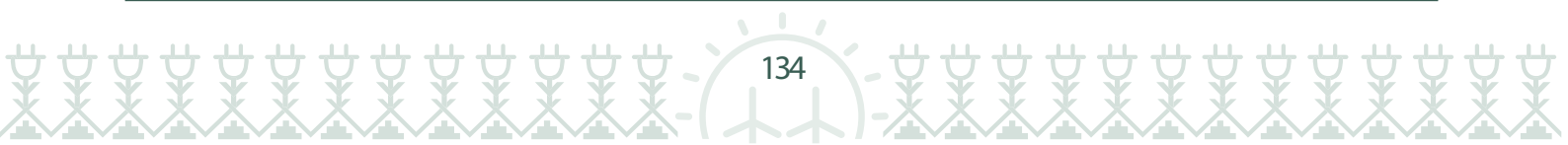
In order to address monetary and non-monetary aspects of a large and small-scale technology deployment, we develop an alternative assessment scheme based on ecological, economic, and social criteria to qualitatively contrast the value of large-scale and small-scale renewable energy technologies. We apply this method to the context of the Global North and the Global South context to evaluate and identify advantages and current barriers as well as disadvantages of each approach from both a system and societal perspective.

### Methods

We develop a three-dimensional assessment scheme based on ecological, economic, and social criteria to estimate the value of the deployment of large-scale or small-scale renewable energy technologies. Each of the dimensions – ecological, economic, and social – is described by a number of criteria that we derived from current studies on the profitability of each approach (acatech, Akademiunion, and Leopoldina 2020; Carbajo and Cabeza 2019; Chilvers, Pallett, and Hargreaves 2018; Tobiasson and Jamasb 2016). These criteria are separately being described in detail and evaluated in the context of deployment of large, medium, and small-scale technologies. Analyzing studies and reports, we find the following criteria driving the discussion about the place of installation:

- Ecology: climate protection, intrusion into natural biosphere, use of resources, land use
- Economy: economic efficiency/viability, technological efficiency, enforceability, regulation
- For a social assessment: acceptance, participation, social equity, health

We take architectures from both decentral and central energy system deployment and qualitatively evaluate them with regard to the named criteria by comprehensively structuring existing results from various research outcomes of studies on each of these categories. The analysis leads to an overview on all impacts, advantages and disadvantages of each of them, and allows for drawing essential conclusions for guiding policy-makers in





accelerating the energy transition. In the broader sense, this assessment scheme can relate to the methodology of identifying strengths and weaknesses.

## Results

In Germany, incentive mechanisms to support the deployment of generation technologies at the location of a load center have not shown the desired increase in installed capacity. Both subsidies that are in place to support the installation of for example rooftop PV suffer from their downsides that in turn lead large players to focus on large-scale projects. However, when comparing residential-scale rooftop PV to large-scale solar and wind parks, we find that the consideration of more than the pure costs of installation for the technology emphasizes the importance of improving policies to support a roll-out of residential systems that are grid connected. The reason is two-fold: First, a pure cost-based approach disregards the costs for infrastructure and technology needed between generation and demand, that is, network expansion to load centers or additional substations. Second, public acceptance rises in the presence of ownership and so does the willingness to participate in the transition. In the current set-up, rights, access, and ownership of roofs, land, and technology are especially critical for residential technology and, thus, pose a challenge to the current incentive mechanism. The results for the economic assessment are most diverse: While we identify a strong support of large-scale deployment by the purely cost-related economic criteria, the regulation shows a lack of space for business models to emerge that support and increase the operation of residential technology.

## Conclusions

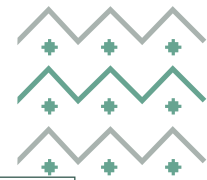
Applying the suggested three-dimensional assessment method, we observe that aside of the pure costs of technology a deployment of residential technology has equally positive aspects as large scale wind and solar parks. In the current debate on the location of wind and solar parks and the lack of space to build these, the parallel support of residential technology allows for an additional pathway to increase aggregated installed renewable energy capacity. Ownership and access rights for small-scale residential technology have so far been one of the major barriers in the current framework: a new model where not only roof and house owners can be sharing the technology and its generation is needed to encourage and accelerate the transition in urban areas.

## References

- acatech, Akademienunion, and Leopoldina, eds. 2020. *Zentrale Und Dezentrale Elemente Im Energiesystem: Der Richtige Mix Für Eine Stabile Und Nachhaltige Versorgung*.
- BMWi. 2019. "Entwicklung Der Erneuerbaren Energien in Deutschland Im Jahr 2018." [https://www.erneuerbare-energien.de/EE/Redaktion/DE/Downloads/entwicklung-der-erneuerbaren-energien-in-deutschland-2018.pdf?\\_\\_blob=publicationFile&v=24](https://www.erneuerbare-energien.de/EE/Redaktion/DE/Downloads/entwicklung-der-erneuerbaren-energien-in-deutschland-2018.pdf?__blob=publicationFile&v=24).
- Borenstein, Severin, and Lucas W. Davis. 2016. "The Distributional Effects of US Clean Energy Tax Credits." *Tax Policy and the Economy* 30 (1): 191–234. <https://doi.org/10.1086/685597>.
- Carbajo, Ruth, and Luisa F. Cabeza. 2019. "Sustainability and Social Justice Dimension Indicators for Applied Renewable Energy Research: A Responsible Approach Proposal." *Applied Energy* 252 (October): 113429. <https://doi.org/10.1016/j.apenergy.2019.113429>.
- Chilvers, Jason, Helen Pallett, and Tom Hargreaves. 2018. "Ecologies of Participation in Socio-Technical Change: The Case of Energy System Transitions." *Energy Research & Social Science* 42 (August): 199–210. <https://doi.org/10.1016/j.erss.2018.03.020>.
- Fraunhofer ISE. 2018. "Studie zu Stromgestehungskosten: Photovoltaik und Onshore-Wind sind günstigste Technologien in Deutschland." Freiburg i. Br.: Fraunhofer ISE. <https://www.ise.fraunhofer.de/de/presse-und-medien/presseinformationen/2018/studie-zu-stromgestehungskosten-photovoltaik-und-onshore-wind-sind-guenstigste-technologien-in-deutschland.html>.
- . 2020. "Recent Facts about Photovoltaics in Germany." <https://www.pv-fakten.de>.
- Lüth, Alexandra, Jens Weibezahn, and Jan Martin Zepter. 2020. "On Distributional Effects in Local Electricity Market Designs—Evidence from a German Case Study." *Energies* 13 (8): 1993. <https://doi.org/10.3390/en13081993>.
- Mathiesen, Brian Vad, Andrei David, Silas Petersen, Karl Sperling, Kenneth Hansen, Steffen Nielsen, Henrik Lund, and Joana Brilhante das Neves. 2017. "The Role of Photovoltaics towards 100% Renewable Energy Systems: Based on International Market Developments and Danish Analysis." Department of Development and Planning, Aalborg University. <https://vbn.aau.dk/da/publications/the-role-of-photovoltaics-towards-100-renewable-energy-systems-ba>.
- Tobiasson, Wenche, and Tooraj Jamasb. 2016. "The Solution That Might Have Been: Resolving Social Conflict in Deliberations about Future Electricity Grid Development." *Energy Research & Social Science* 17 (July): 94–101. <https://doi.org/10.1016/j.erss.2016.04.018>.







## PERFORMANCE INVESTIGATION OF TWO TYPES OF SOLAR CHIMNEY USED FOR AIR CONDITIONING

Hamod Ghorm Ali Alshomrsni

Mechanical Engineering Department, College of Engineering, University of Bisha, Bisha 61922, Saudi Arabia, [tel: +966501642625, alrahal2000@hotmail.com](mailto:alrahal2000@hotmail.com),

Faouzi Nasri

Mechanical Engineering Department, College of Engineering, University of Bisha, Bisha 61922, Saudi Arabia, [tel:+966590320696, fnasri@ub.edu.sa, nasrifaouzi@yahoo.fr](mailto:fnasri@ub.edu.sa)

### Overview

Nearly 35 % of total worldwide energy production is consumed by the building sector. In the European Union, the overall energy consumption by buildings account for 40%, and approximately 30 % of the building energy is consumed by heating, ventilation and air-conditioning. Ventilation is the simplest, oldest, and least expensive form of passive cooling or heating. In the last years, researchers focused on the natural ventilation. Natural ventilation induced by solar chimney is an excellent passive system for air exchange that provides outdoor fresh and unpolluted air. Moreover, many current scientific researches have shown the possibility to enhance indoor natural ventilation in buildings by using solar chimneys. Shuangping Duan et al analysed the airflow in a building occupied by solar chimney and fans. The results of this study showed that the airflow rate boosts if the height of the solar chimney and solar radiation increase. The deduced also, that using fans will decrease the natural ventilation generated by solar chimney. E.P. Sakonidou et al. Investigated the optimal angle that will provide a maximum airflow by natural ventilation in solar chimney. Developed model permitted flowing many parameters such air velocity and the temperature variation inside the chimney.

### Methods

The Figures 1 and 2 illustrate a schematic diagram of the ventilated building for the two proposed types of solar chimney. The solar chimney uses the sun's heat to provide ventilation based on the pressure difference between building air inlet and air outlet. Solar radiation is used to heat up the air flow in the collector in order to enhance ventilation in the chimney. The solar chimney Type I is a conventional design with a simple vertical part while the solar chimney type II is our proposed original design with a lateral (vertical) part and an upper (horizontal) part.

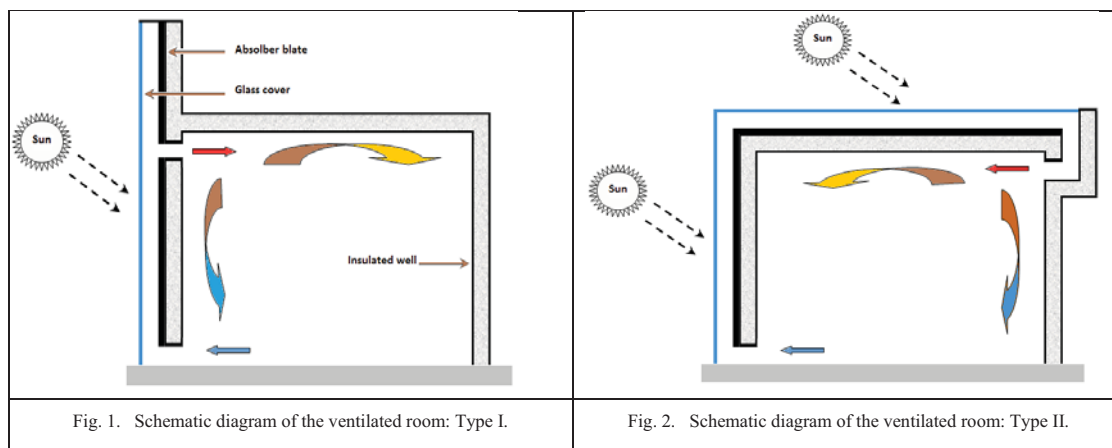


Fig. 1. Schematic diagram of the ventilated room: Type I.

Fig. 2. Schematic diagram of the ventilated room: Type II.

A solar chimney is a type of passive solar heating and cooling system composed of a glass, air and absorber. The natural air flow within the solar chimney due to the difference of the density varied with vertical direction is considered steady and with negligible resistance losses. That can be used to regulate the temperature of a building as well as providing ventilation is considered steady and with negligible resistance losses. The energy balances for each component are written as (Nasri et al., 2018):





## Results

All numerical simulations are carried out for an ambient temperature  $T_a=15^\circ\text{C}$ , solar radiation  $I=500\text{W/m}^2$ , all wall temperatures are unique  $T_w=15^\circ\text{C}$ . The chimney cross section is  $A_{ch}=0.3\times 1\text{m}^2$  for the two investigated types of solar chimney. For the solar chimney Type I, the air flow velocity in the chimney is  $V_{ch}=0.13\text{ m/s}$  and the outlet chimney temperature (inlet room temperature) is  $T_{out,ch}=27.5^\circ\text{C}$ . The Figures 3 and 4 present the air temperature evolution and the air temperature contours respectively for the solar chimney Type I. This study will present the air streamlines, the air temperature evolution and the air temperature contours respectively for the solar chimney Type II.

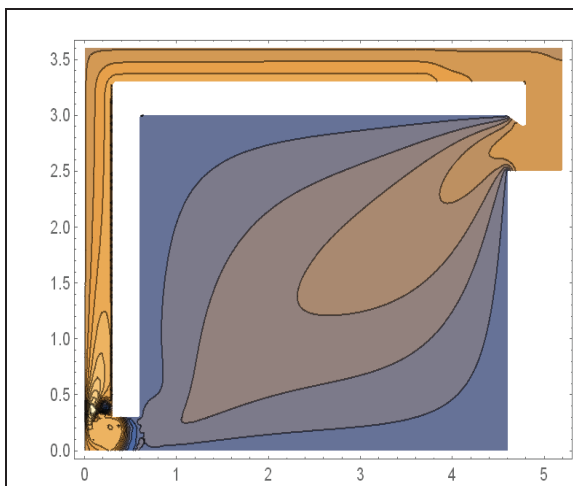


Fig. 3. Air temperature evolution for the ventilated room: Type II.

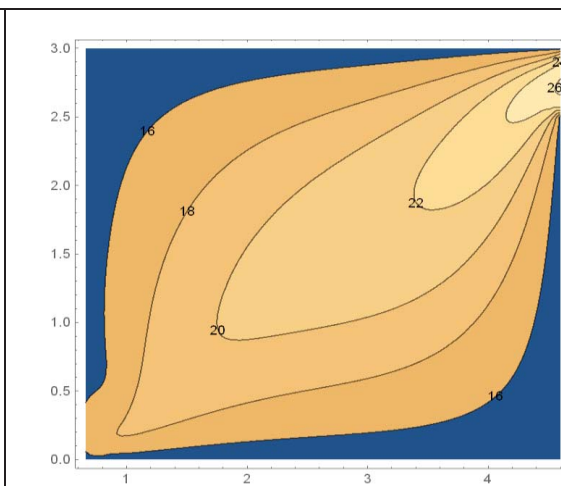


Fig. 4. Air temperature contours for the ventilated room: Type II.

Base on the numerical results, the proposed original design of solar chimney (solar chimney Type II) provides better distribution of heated air in the ventilated room than the conventional one (solar chimney type II). We carried out numerical results of the calculated exit air velocity and the calculated air temperature respectively in function of solar heat flux.

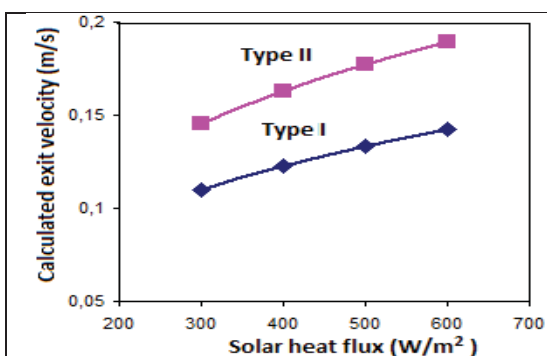


Fig. 5. Calculated exit air velocity: solar chimney Type I vs solar chimney Type II.

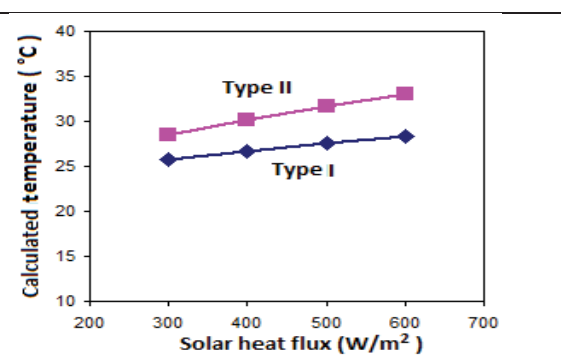
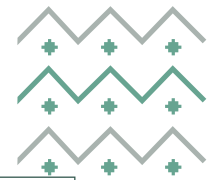


Fig. 6. Calculated exit air temperature: solar chimney Type I vs solar chimney Type II.

## Conclusions

An original design of solar chimney with lateral (vertical) part and upper (horizontal) part is proposed. The proposed design permits to ensure thermal comfort in a ventilated room during winter mode. A comparative numerical study between the conventional and the proposed original designs is carried out to evaluate the ability of each design to ensure indoor thermal comfort. Results show that the original design of solar chimney presents better performance than the conventional one.



## IS LEARNING CURVE ON SOLAR PHOTOVOLTAIC INSTALLATION AFFECTED BY RENEWABLE POLICY AND REGIONAL CHARACTERISTICS?

Saiful Arefeen, Graduate School of Economics, Ritsumeikan University, Japan, gr0252eh@ed.ritsumei.ac.jp

### Overview

Solar photovoltaic (PV) has been regarded as the fastest-growing, ecologically and economically feasible energy source for over a decade. The fundamental issue in the penetration of solar PV technologies is that traditional technologies have already amortized their investments, making them more profitable and competitive, but innovative technologies such as solar PV require a start-up investment. Installation cost reduction has played a crucial role in energy transition and solar PV development. It was discovered that capital expenditure is one of the most significant financial barriers to solar PV uptake. The capital cost of solar PV may be broken down into two parts: the 'module', which converts sunshine to energy, and the 'other costs', which include installation, inverter, labour, mount, cable, permitting, and grid connection. The cost-share in capital investment of solar PV installation has observed a dramatic change recently. The module price has declined faster than the 'other cost'. While module costs are internationally priced and well-documented, 'other costs' are little known. Furthermore, each location or nation has unique cost elements as a result of industry, legislation, energy objectives, and the environment. As a result, knowing the pace of cost reduction in 'other costs (other than module price) components in solar PV by renewable policy (such as feed-in tariff vs without feed-in tariff), country class (developed vs developing), and geographical regions is crucial for policymakers. The future capital investment of solar PV, which is related to a cleaner energy future, will decide its continuous acceptance, and the learning curve (LC) will influence policy circles. The learning curve (LC) idea is valuable because it clarifies how expenses have changed over time. This study will help forecast future solar PV capital expenditures and pricing more accurately. Because these systems rely on private market reactions to legislative frameworks, and private investment decisions are sensitive to local cost situations, this is crucial for spreading PV on rooftops of homes and businesses.

### Methods

The data has been extracted for various countries yearly (1995-2020) from different sources such as the OECD, World Bank, IEA and IRENA to conduct panel data estimations. The study considers the following learning curve (LC) specification can be expressed as (Trappey et al., 2016):

$$C_{qit} = C_{1it}CC_{it}^{\gamma} \in \dots\dots\dots(1)$$

Where  $C_{qit}$  is the marginal cost of producing the q-th unit for the country ( $i = 1, 2, \dots, 26$ ) and year ( $t = 1995, 1996, \dots, 2020$ );  $C_1$  is the cost of producing the first unit,  $CC$  is the cumulative installed capacity and  $\gamma$  is the learning index or the experience parameter can be expressed as  $\gamma = (\beta_1 + \beta_2X_1 + \dots + \beta_nX_n)$ . Expressing equation-1 in log form and considering  $\gamma$  parameter, we can obtain a simple model suitable for regression analysis.

$$\ln C_{qit} = \ln C_{1it} + \gamma \ln CC_{it} + \ln \in \dots\dots\dots(2)$$

$$\ln C_{qit} = \ln C_{1it} + \beta_1 \ln CC_{it} + \beta_2 X_1 \ln CC_{it} + \dots + \beta_n X_n \ln CC_{it} + \ln \in \dots\dots\dots(3)$$

Where  $C_{qit}$  and  $CC_{it}$  indicate the 'other costs (does not include module cost)' and cumulative installed capacity, respectively.  $\beta_1$  represents the coefficient of the cumulative installed capacity. ( $X_1, X_2, \dots, X_n$ ) denote possible moderating factors and ( $\beta_2, \beta_3, \dots, \beta_n$ ) are their coefficients. The learning curve (LC) will be  $2^\beta$  (where  $\beta < 0$  implies positive learning) showing the percentage change in cost due to the doubling of cumulative installed capacity.

A single-factor learning curve may neglect essential components and leads to estimation bias (Trappey et al., 2016). As a result, the study attempts a multi-factor learning curve. We have considered learning curves of one factor (PV cumulative capacity) and two (PV cumulative capacity and labour cost) learning curves. The dependent variable is the capital cost (per Watt installation cost in USD), and the independent variables inspected are solar PV cumulative capacity (Watt) and labour cost (USD/hour), which can significantly affect the 'other costs (excluding module cost)' of solar PV. We express capital and labour costs relative to the GDP deflator to adjust inflation. Several econometric models, such as ordinary least square, random effect and fixed effect model, were employed to investigate the learning curve. Moreover, we have transformed the relevant variables in appropriate scale and corrected the data for unit root, multicollinearity, heteroscedasticity, omitted variable bias and endogeneity to get the robust results.

### Results

We investigated the 'other expenses' with solar PV cumulative capacity in the one-factor model (Table-1 (column-1, 3 and 5) and the labour cost in the two-factor model (Table-1 (column-2, 4 and 6) as well. In all models, findings revealed that cumulative capacity and labour cost had a substantial impact on the 'other expenses (excluding module cost)' component of a photovoltaic installation. The solar cumulative capacity learning parameter is negative for all models, suggesting that there is positive learning of 'other cost' components of a solar photovoltaic installation. The significant learning rate for 'other expenses' of solar power installation is 77.38



percentage ( $\beta_1 = -0.37$ ) in the whole sample means that for each time the cumulative solar capacity doubles in the two-factor model (Table-1, column-2), the new production cost will be 77.38% of the initial cost.

Table-1: The learning curve of solar photovoltaic in 'other costs (excluding module cost)' using fixed-effect or random-effect model

Variables	(1)	(2)	(3)	(4)	(5)	(6)
	Ln (other costs)					
	Overall		FIT policy		Without FIT policy	
	One-factor	Two-factor	One-factor	Two-factor	One-factor	Two-factor
Ln (solar cum. capacity)	-0.22*** (0.02)	-0.37*** (0.03)	-0.29*** (0.04)	-0.34*** (0.05)	-0.19*** (0.04)	-0.48*** (0.03)
Ln (solar cum. capacity)* labour cost	-	0.01*** (0.001)	-	0.01*** (0.001)	-	0.01*** (0.001)
Constant	2.93*** (0.18)	3.44*** (0.25)	3.43*** (0.24)	3.27*** (0.39)	2.74*** (0.24)	3.51*** (0.16)
Observations	343	159	182	90	160	68
R-squared	0.27	0.46	0.20	0.26	0.28	0.78
Number of country	26	14	22	11	24	13
LR-test	94.63***	60.59***	-	38.43***	57.57***	-
F-test	-	-	6.51***	-	-	14.22***
Breusch-pagan (LM) test	329.27***	241.39***	-	141.34***	124.71***	-
Hausman	0.05	0.50	4.11**	0.68	1.79	1038.0***
AIC	963.89	397.04	444.79	253.42	442.63	21.40
Learning curve ( $2^\beta$ ) (%)	85.86	77.38	81.79	79.0	87.66	71.70
Progress ratio ( $1 - 2^\beta$ ) (%)	14.14	22.62	18.21	21.0	12.34	28.30

Standard errors in parentheses \*\*\* p<0.01, \*\* p<0.05, \* p<0.1

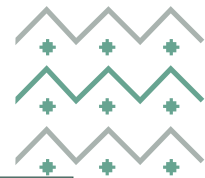
Policy learning has emerged in recent years as an innovative way of exploring the roles of knowledge acquisition and use in policy change to renewable development. It is argued that interpreting 'other costs' in solar photovoltaic power installation through the lens of feed-in tariff policy learning yields fresh perspectives on why policies develop in specific directions and not others. The feed-in tariff is a price-based subsidy policy for renewable generators, which sets a guaranteed price to be paid to renewable producers per kilowatt-hour (kWh) of electricity generated. The results reveal that although the learning rate in the 'other costs' component of solar installation is significant in both countries with or without renewable policy (feed-in tariff), the learning rate is higher in the countries with the renewable policy. In the two-factor model (Table-1, column-2, 4 & 6), the overall learning rate is 77.38%, whereas the learning curve is 79% for the FIT policy presence and 71.7% for the feed-in tariff policy absence.

## Conclusions

To examine the learning curve coefficient on solar photovoltaic power installation, we used the learning curve approach and applied multiple econometric models such as fixed-effect and random-effect. The results reveal that the 'other costs (excluding module cost)' learning curve, and its segmentation by renewable policy (such as feed-in tariff) have a substantial positive learning effect on solar photovoltaic installation. In comparison to nations without a feed-in tariff policy, countries with a feed-in tariff policy have a greater learning rate. Policymakers may use this learning curve to forecast future solar photovoltaic penetration and policy interventions on cost structures in order to penetrate solar photovoltaic and promote clean energy globally.

## References

Trappey, A. J., Trappey, C. V., Tan, H., Liu, P. H., Li, S. J., & Lin, L. C. (2016). The determinants of photovoltaic system costs: an evaluation using a hierarchical learning curve model. *Journal of Cleaner Production*, 112, 1709-1716.



Renewables

## CROSS-BORDER POWER TRADE AND RENEWABLE ENERGY DEVELOPMENT IN SOUTHEAST ASIA: ECONOMIC AND ENVIRONMENTAL IMPLICATIONS

Youngho Chang, Singapore University of Social Sciences, +65-6248-0159, yhchang@suss.edu.sg

### Overview

The Association of Southeast Asian Nations (ASEAN) has been working on utilizing its energy resources scattered across the region through the integrated grid networks such as the ASEAN Power Grid (APG) and the Trans ASEAN Gas Pipelines (TAGP). The power trade in the Great Mekong Sub-region (GMS) is a successful pioneer of cross-border power trade in the region. The ASEAN member countries, especially five countries in the GMS, namely Cambodia, Lao PDR, Myanmar, Thailand and Viet Nam have huge potential in hydropower (Chang and Li, 2013; Li and Chang, 2015; ASEAN Centre for Energy, 2022; Tran and Suhardiman, 2022). Table 1 presents the actual capacity of hydroelectricity as of 2018 and the potential capacity of hydroelectricity in the five GMS countries.

Table 1: Actual (2018) and Potential Capacity of Hydroelectricity in the GMS (unit: MW)

Capacity/Countries	Cambodia	Lao PDR	Myanmar	Thailand	Viet Nam	Total
Actual	1,330	5,472	3,259	3,103.4	20,170	33,334.4
Potential	26,417.27	48,949.64	108,000	12,431.65	95,568.35	291,366.91
Utilization (%)	5.03	11.18	3.02	24.96	21.11	11.44

Source: Chang and Li (2015), ASEAN Centre for Energy (2022)

As shown in table 1, the utilization rates of the hydroelectricity potential for the five GMS countries are ranging from about 3% (Myanmar) to about 25% (Thailand), and 11.44% at an aggregate level. The potential capacity of hydroelectricity is huge, but the development of the potential capacity into actual one has been slow and a lack of interconnections between the supply sources of hydroelectricity and the demand sources of hydroelectricity is one of the key reasons for the slow development (Do and Burke, 2022). As of April 2020, the existing capacity of cross-border bilateral interconnections in the ASEAN is 7,720MW, the ongoing capacity is from 555MW to 625MW and the future capacity is from 18,369 to 21,769MW (ASEAN Centre for Energy, 2021).

Most cross-border interconnections within the Southeast Asia are the direct or dedicated connection between the source of exporting system to the source of importing system and no access is given to a third party. Dedicated interconnections could hinder the development of full-pledged open access interconnections of power grids in the region (Ricardo Energy and Environment, 2019). Using an ASEAN power trade model, this study aims to fill the gap in the literature to vindicate how power trade in the region will ensure the development of hydroelectricity. It also aims to draw economic and environmental justifications of cross-border bilateral and open-access interconnections that would help the region cooperate and accelerate the development of renewable energy, mainly hydroelectricity.

This study scans and collects information relating to the status of cross-border bilateral interconnections in the region. It updates the values of the variables and parameters used in the ASEAN power trade model, and afterward it modifies the model to incorporate cross-border bilateral interconnections into the framework and later to develop a full-pledged open access interconnections. Using the General Algebraic Modelling System (GAMS), it solves the model and derives solutions and policy implications.

### Methods

This study adopts a dynamic linear programming framework in power generation first developed by Turvey and Anderson (1977) and later adapted by Chang and Tay (2006) and Chang and Li (2013). In the latest study of Chang and Li (2013), significant extensions of the original models were made. A new country dimension was added to allow an international framework with cross-border electricity trade. The new model also added the cost of cross-border power transmission as well as transmission loss into account. Carbon emissions from power generation as well as the carbon cost of power generation were explicitly considered.

The model sets an objective function and includes various constraints such as resource endowments, technologies, capital and operation costs, costs of interconnections and carbon emissions, among others. The objective function is





stated as to minimize the cost of meeting electricity demand by taking account all resource endowments, available technologies and constraints. There are several constraints that are required to optimize the above objective function. To ensure meeting domestic demand and trading surplus electricity, this study has a few key assumptions. First, total installed capacity of power generation in the region should be greater or equal to total demand for electricity in the region. Second, the total output of electricity generation in each country is constrained by the load factor of each installed capacity of all types of electricity generation in the country. Third, the electricity supply of all countries in the region to a certain country should be greater than or equal to the demand for electricity in the country. Fourth, the total supply of electricity from one country to all countries (including the country itself) in the region must be smaller or equal to the total available supply capacity of the country at a given time.

The base case of this study is a replication of the current system-to-system interconnections in the region where no third party or open access is allowed (Ricardo Energy and Environment, 2019). Along with the base case, this study develops a few scenarios by adopting various business plans of interconnections. It also develops a few more scenarios of full-pledged cross-border interconnections with environmental consideration of imposing carbon taxes where third party or open access is allowed.

## Results

This study presents the following results. First, it presents economic costs of hydroelectricity development for the GMS under the current system-to-system interconnections. Second, it presents the estimated total costs of meeting electricity demand for the GMS and country-specific net gains that could be negative for some countries under the various scenarios of business plans of interconnections. Third, it presents environmental costs of developing hydroelectricity in the GMS. Finally, it presents how the environmental consideration such as imposing carbon taxes influences the development of hydroelectricity in the GMS and the degree of mitigating the negative environmental consequences in the GMS.

The findings of this study are expected to present a few policy implications. First, this study can help the GMS countries identify business plans of interconnections in economic and environmental terms and evaluate the pros and cons of various system-to-system interconnections. Second, it also can help the GMS countries prioritize the investment order of cross-border interconnections. Third, it can help the GMS countries measure the relief or burden of carbon taxes through the development of hydroelectricity in the GMS. Finally, the findings can shed light on the level of carbon taxes and the speed of hydroelectricity integration into the power system in the GMS countries as a whole so that the GMS countries can plan and adjust the speed of developing hydroelectricity.

## Conclusions

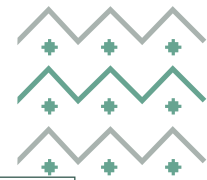
The results of this study are expected to help the region identify business plans of interconnections in economic and environmental terms and evaluate the pros and cons of various system-to-system interconnections. The study also can help the region prioritize the investment order of cross-border interconnections. In addition, it can help the region measure the relief or burden of carbon taxes through the development of hydroelectricity in the region. Finally, the findings can shed light on the level of carbon taxes and the speed of hydroelectricity integration into the power system in the region as a whole so that the region can plan and adjust the speed of developing hydroelectricity.

## References

- ASEAN Centre for Energy (2021): ASEAN Power Grid (APG): Regional integration on electricity interconnectivities, SIEW Thinktank Roundtable, 29 October 2021, Singapore.
- ASEAN Centre for Energy (ACE) (2022), <https://aseanenergy.org/work/data-statistic/>
- Chang, Youngho and Yanfei Li (2013): "Power generation and cross-border grid planning for the integrated ASEAN electricity market: A dynamic linear programming model," *Energy Strategy Reviews*, 2: 153 – 160.
- Do, Trang Nam and Paul J. Burke (2022): "Is ASEAN ready to move to multilateral cross-border electricity trade?" *Asia Pacific Viewpoint*, ISSN 1360-7456
- Li, Yanfei and Youngho Chang (2015): "Infrastructure investments for power trade and transmission in ASEAN+2: Costs, benefits, long-term contracts and prioritized developments," *Energy Economics*, 51: 484 – 492.
- Li, Yanfei, Tsani Fauziah Rakhmah and Junichi Wada (2020): "Market design for multilateral trade of electricity in ASEAN: A survey of the key components and feasibility," *Asian Economic Papers*, 19(1): 43 – 60.
- Ricardo Energy and Environment (2019): *Greater Mekong Subregion Power Market Development: All Business Cases including the Integrating GMS Case*, Didcot, the United Kingdom.
- Tran, Thong Anh and Diana Suhardiman (2022): "Laos' hydropower development and cross-border power trade in the Lower Mekong Basin: A discourse analysis," *Asia Pacific Viewpoint*, 61(2): 219 – 235.
- Turvey, R. and D. Anderson (1977): *Electricity Economics: Essays and Case Studies*. The John Hopkins University Press, Baltimore and London.







Renewables

## CAUSAL RELATIONSHIPS BETWEEN RENEWABLE ENERGY PATENTS AND RENEWABLE ELECTRICITY GENERATION AMONG 18 OECD COUNTRIES

Eunnyeong Heo, Seoul National University, +82-10-4582-8323, [heoe@snu.ac.kr](mailto:heoe@snu.ac.kr)  
 Professor, Former Vice President of IAEE  
 Yeongju Yun, Seoul National University, +82-10-5492-8871, [yeongju0410@snu.ac.kr](mailto:yeongju0410@snu.ac.kr)  
 Ph.D. Candidate

### Overview

This study analyzes effects of technology R&D performances as a policy variable towards the expansion of renewable electricity generation among 18 OECD countries. We use US patents in the area of renewable energy, especially solar and wind as the variables to represent output of a country's R&D activities. We use annual data from 1990 to 2015 of 18 OECD countries. Estimation results show that patents have positive effects on renewable electricity generation and are statistically significant across all 18 countries. Germany, Spain, and United Kingdom show the highest effects among 18 OECD countries analyzed.

### Methods

This study uses a panel econometric model:

$$u_{it} = \alpha + x_{it}\beta + z'_{it}\gamma + \alpha_i + \epsilon_{it}$$

where  $u_{it}$  is renewable electricity generation of I country in t year,  $x_{it}$  is the number of US patents in renewable electricity fields of I country in t year,  $\alpha_i$  and  $\epsilon_{it}$  are error terms. We use annual data from 1990 to 2015 of 18 OECD countries.

### Results

Estimation results show that patents have positive effects on renewable electricity generation and are all statistically significant across 18 countries. We also find that a fixed-effects model is more efficient by the Hausman test. Results show that the size and sign of the coefficients remain constant with different sets of control variables in the model, confirming that the estimation model of this study is solid and stable.

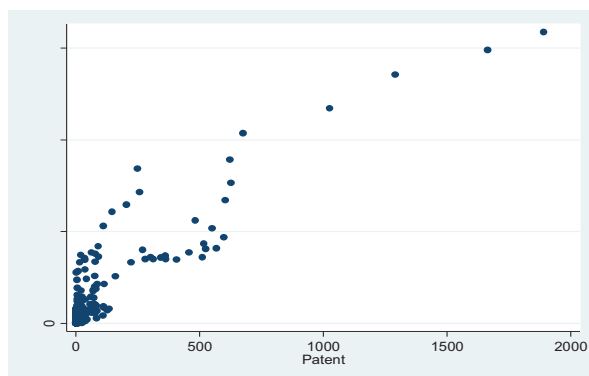


Figure. Plots between Renewable Energy Patents and Renewable Electricity Generation







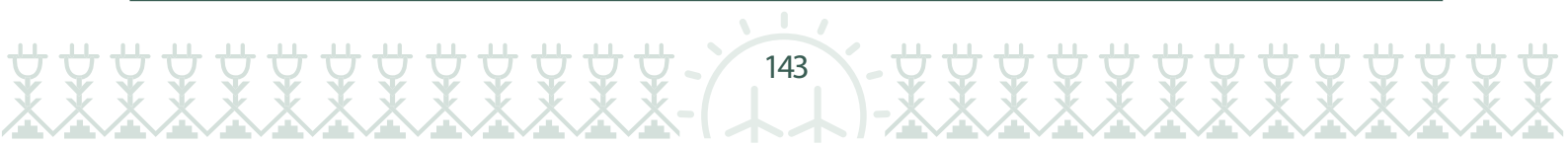
Among 18 countries analysed, Germany, Spain, United Kingdom show the highest effect. These three countries all have high numbers of renewable energy patents. On the other hand, Korea, even with high numbers of patents, shows below-average coefficient values in policy variables, indicating that the relation between R&D policy and renewable energy dissemination policy is still at a low level.

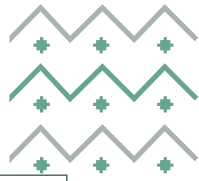
## Conclusions

This study's results show that to enhance renewable energy production, technology R&D activities have highly positive impacts for the purpose. Among 18 OECD countries examined, Germany, UK and Spain come with the highest effects and those countries all have high numbers of renewable energy patents. These results give policymakers a concrete fact that technology development policy is one of the main policy tools for renewable energy opportunities and challenges.

## References

- Alam, M.S., Apergis, N., Paramati, S.R., and Fang, J., 2021, "The impacts of R&D investment and stock markets on clean energy consumption and CO2 emissions in OECD economies", *International Journal of Finance & Economics*, 26, 4, 4979-4992.
- Albino, V., Ardito, L., Dangelico, R.M., and Petruzzelli, A.M., 2014, "Understanding the development trends of low-carbon energy technologies: A patent analysis", *Applied Energy*, 135, 836-854.
- Carley, S., 2009, "State Renewable Energy Electricity Policies: An Empirical Evaluation of Effectiveness", *Energy Policy*, 37, 8, 3071-3081.
- Choi, G.B., E. Heo and C.Y. Lee, 2018, "Dynamic Economic Analysis of Subsidies for New and Renewable Energy in South Korea", *Sustainability*, 10, 6, 1832.
- Kim, E.S., and E. Heo, 2016, "Analysis on the Effects of Renewable Policies in OECD Countries Using Dynamic Panel Model", *Environmental and Resource Economics Review*, 25, 2, 229-253.
- Yoon, J.Y., 2020, "A Panel Data Analysis on Policy Instruments for Renewable Energy Deployment", M.S. thesis, Seoul National University, Seoul, Korea.
- Yun Y., 2022, "An International Comparative Analysis of the Effects of Patents and R&D Investment as a Policy Measure for Expanding Renewable Energy Generation", M.S. thesis, Seoul National University, Seoul, Korea.





## IMPROVED COORDINATED PROTECTION SCHEME FOR DFIG BASED WIND TURBINES

Arshad Arshad, School of Computing, Engineering and Built Environment, Glasgow Caledonian University, +441412731486, Arshad.arshad@gcu.ac.uk

Wahab Ali Shah, Namal University, Mianwali, Pakistan, wahab@namal.edu.pk

Sali Issa, Department of Physics, Mechanical and Electrical Engineering, Hubei University of Education, Wuhan, China, sword-lily@hotmail.com

### Overview

Doubly Fed Induction Generator (DFIG) is one of the popular choices for wind generation due to its variable speed operation, low losses and relatively low cost as compared to fully rated converter-based wind turbines. However, there are many disadvantages as well of DFIG generation system such as vulnerability to grid disturbance due to direct connection between stator and grid [1]. The increased sensitivity of DFIG wind turbine to voltage sags requires additional protection scheme for Rotor Side Converter (RSC) [2], [3]. Power electronic converters protection in DFIG based system is very important to avoid any over/under voltage and overcurrent situation during faults.

### Methods

The simulation setup includes a DFIG wind turbine with 690V at its terminals and is connected with step up transformer. A step-up transformer (0.69/33 kV) is used to step up the voltage for collection purposes. A step-up transformer (33/132 kV) to increase voltage suitable for transmission at long distances is used. A 50 km HVAC transmission line is utilized for power transfer to the grid. The simulations were performed in the following steps:

1. Steady state simulations under no fault and without any protection scheme
2. Turbine terminal, grid side, and transmission line was subjected to a three-phase short circuit fault.
3. An active crowbar and DC chopper were connected to rotor windings and simulations were repeated.
4. Value of crowbar resistance, fault resistance and chopper resistance were

### Results

The parameters measured throughout the simulations are turbine's active and reactive power, DFIG stator current and voltage, rotor current and voltage. Per unit system was adopted for the measurement of stator current and voltage, whereas, actual values were used for the measurement of DC-link capacitor voltages, active power and reactive power. Fig. 1 shows the results of DC link voltage, reactive power and active power during fault. Overcharging of DC capacitors results in a remarkable increase of DC link voltage that reaches 2450V throughout the fault. Power electronic converters and capacitor can be damaged due to this increase in DC link voltage. These consequences show that the reliability and safety of power system operation is compromised resulting in significant damage to the turbine when the transmission line is subjected to a the phase short circuit fault which means that a protection strategy is required to cope with the situation.

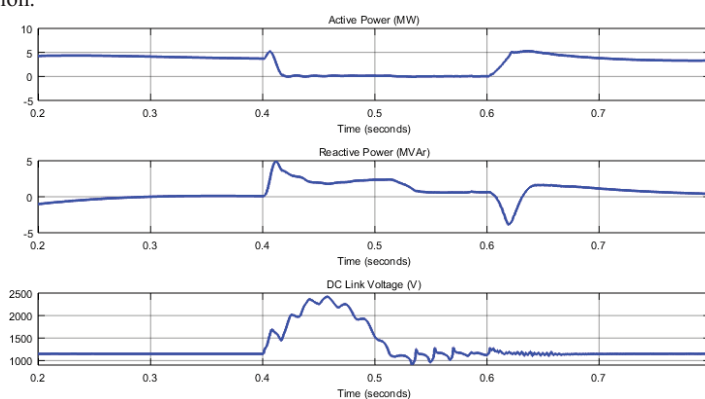
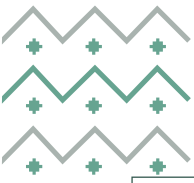


Fig. 1 Behaviour of DC-link voltage, reactive power and active power at fault





## Conclusions

This paper discusses the importance of protection schemes for DFIG based wind generation system during grid disturbances. Two different types of protection schemes are designed and implemented namely crowbar and DC chopper. Finally, a coordinated protection scheme consisting of both schemes is implemented which shows better results than individual crowbar and DC chopper protection. These results can strengthen our knowledge about the FRT behavior of DFIG wind turbines under different types of grid disturbance and protection scheme.

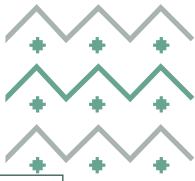
## References

- [1] J. Yang, J. E. Fletcher, and J. O'Reilly, "A series-dynamic-resistor-based converter protection scheme for doubly-fed induction generator during various fault conditions," *IEEE Trans. Energy Convers.*, vol. 25, no. 2, pp. 422–432, 2010.
- [2] J. Lopez, E. Gubia, P. Sanchis, X. Roboam, and L. Marroyo, "Wind turbines based on doubly fed induction generator under asymmetrical voltage dips," *IEEE Trans. Energy Convers.*, vol. 23, no. 1, pp. 321–330, 2008.
- [3] M. Mohseni, S. M. Islam, and M. A. Masoum, "Impacts of symmetrical and asymmetrical voltage sags on DFIG-based wind turbines considering phase-angle jump, voltage recovery, and sag parameters," *IEEE Trans. Power Electron.*, vol. 26, no. 5, pp. 1587–1598, 2011.



Renewables





## ***RENEWABLES OPPORTUNITIES AND CHALLENGES***

Sara Alalqam, King Faisal University, Saudi Arabia, +966 500 096820, [sarapeters.pe@gmail.com](mailto:sarapeters.pe@gmail.com)  
Ayidh Al Swidan, Business Development Manager, +966 583 732333, [aalq058373@gmail.com](mailto:aalq058373@gmail.com)

### **Overview**

The world is rapidly shifting to renewable energy sources. There's unprecedented momentum for reducing dependence on fossil-based energy. Nevertheless, climate change, oil and gas price volatility, geopolitics, and emissions make the oil and gas industry uncertain. In response to this uncertainty, governments across the globe have shifted their policies, financial plans, and priorities to favour renewable energy.

The Kingdom of Saudi Arabia is a fertile environment for renewables investment; renewables investment is a key factor in economic growth and aligns with Vision 2030.

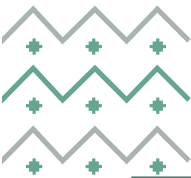
Apart from the available assets and capacities, Saudi Arabia has a significant advantage in achieving a high level of renewables production compared to others.

For example, the perfect georgical location that connects three big markets ( Asia, Africa, Europe ) and the massive natural gas production in Saudi Arabia have resulted in blue hydrogen gaining an advantage. By keeping natural gas at its current low price of \$1.25/MMBtu, the cost of producing blue hydrogen could fall from \$1.34/kg to \$1.13/kg by 2030. Whereas In Saudi Arabia, the cost of producing green hydrogen could fall to \$1/kg by 2050.

### **Methods**

Identify and evaluate some of the global and local renewable energy opportunities and challenges. Based on the results of the analysis, recommendations were made.





## Results

Challenge (1) Raw minerals such as Silicon, silver, steel, aluminium, uranium, Lithium, nickel, cobalt, copper, and other rare earths are significant elements in many technologies required in energy transitions. The transition to a clean energy system increases the demand for these minerals dramatically. However, for most minerals, available quantities represent only a small portion of total demand. Opportunity: Limiting the use of rare earths. Considering the circular economy to create sustainable solutions.

Challenge (2) Given the limitations of the countries where these raw materials can be found, a monopolized market has formed. China, for example, has 97% of the total available rare earths. Opportunity: global policymakers need to secure the supply chains, improve the market transparency, develop response capabilities to potential supply disruptions and contingency plans for possible geopolitical conflicts. Strengthen international collaboration between producer countries and consumer countries.

Challenge (3) Lack of financial plans and investment strategies, which causes energy transitions to be delayed. Opportunity: enhance the investment by creating conditions conducive to diversified investment in the mineral supply chain.

Challenge (4) Environmental harm. Wind energy can harm birds through direct collisions with turbines and other structures. Mining is an invasive process that cause serious damage to the landscape, release of greenhouse gasses, mining can lead to the loss of plants and animals, affecting ecosystem, soil toxicity and habitat loss. Opportunity: control the unregulated mining operations, improve the legislation and regulations, improve environmental performance, create solutions for the toxic mining waste and reusable waste.

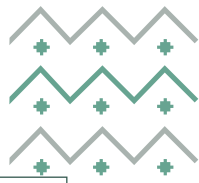
## Conclusions

Although, many industrialized economies are working aggressively to develop alternative non-oil-based energy sources, their emerging counterparts continue to rely on relatively cheaper hydrocarbon-based energy sources to increase their productive capacities, at least for the foreseeable future. The feasibility of a complete transition to unconventional energy sources is far from reality because renewable energy development and investment face numerous technical, economic, and geopolitical challenges, technically, economically, and geopolitically. Synergizing the traditional energy source and the renewables, can be the key to maximizing the energy industry efficiency, fulfill the demand and reduce carbon footprint. It builds a more resilient core business. Explore the possible hydrogen investment opportunities through the production of natural gas which eventually helps in achieving a cleaner, more affordable, and secured energy. Generate thermal energy from burning excess natural gas on oil rigs can be an added benefit.

## References

- International Energy Agency (2014). "World Energy Outlook 2014". International Energy Agency.
- Arena.org
- Aramco.com
- PIF.gov.sa





## Abstract

**College:** College of Engineering and Science

**Department/Program:** Renewable Energy Program

**Specialization/Track:** Solar Energy Technology

**Title:** Ground Source Ventilation and Solar PV towards Zero Carbon Houses in Riyadh

**Student Name:** Osamah bin Saad Alanazi

**Supervisor Name:** Muhammad Ghazi Kotbi, Muhammad Omar Alfadil

**Degree:** Master's

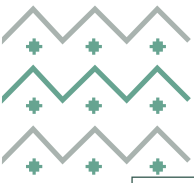
**Discussion date:** 06/26/2022, 27/11/1443

**Keywords:** Zero Energy Buildings, Renewable Energy, Solar Energy, Geothermal Energy, Zero Carbon

### Abstract:

While renewable energy technology is developing in the Kingdom of Saudi Arabia (KSA), and the ambitious 2030 vision encourages the shift towards more efficient and clean energy usage. The research on the application of geothermal resources in the residential use for Saudi Arabian context will contribute towards a more sustainable environment. This paper's main goal was to investigate the possibility of achieving a zero-carbon house in the capital city of Riyadh, by applying a ground coupled system into a current sustainable house that uses a grid-tied solar system. The current house was built and designed by King Saud University for the 2018 Solar Decathlon Middle East competition. However, the house failed to reach zero-carbon operation due to the high cooling demand. This study redesigned and validated the house using Revit and Carriers Hourly Analysis (HAP) software. After that, a ground source ventilation system was designed using the GCV Tool to reduce cooling loads. After the application of the ground source system, the new electrical loads were compared with the current house. Finally, a simple economic analysis that includes the cost of applying the ground source system was reported. The findings of this study indicated that the current solar house with all its features is not capable of reaching zero-carbon using a ground-coupled ventilation system. Further findings showed that zero-carbon is only possible if current design changes were made, such as electrical appliance schedules. The same findings showed that there is no feasibility of building such a house, since the main purpose was to compete for a contest. However, the findings suggest that if the same GCV system designed in this study was applied to typical houses, there might be better



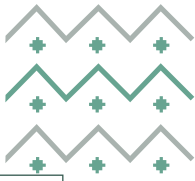


economic feasibility. While cooling in the residential sector is the dominant energy consumer in the Gulf region, this work will certainly help in moving towards using renewable sources to meet those demands. This paper was limited to the current built house and has not changed any design features except for the addition of the ground source ventilation system.



Renewables





## The Korean REC Spot Market Price Forecasting Based on AI-based Statistical Methodologies

Jong-Bae Park, Konkuk University, +82-2-450-3483, jbaepark@konkuk.ac.kr  
 Sung-Hee Lee, BRFrame Inc., sunghline@brframe.com  
 Woo-Nam Lee, Korea Electrotechnology Research Institute, wnlee@keri.re.kr  
 Manho Joung, Sempra Energy, mjoung@sempra.com  
 Da-Han Lee, Konkuk University, +82-2-458-4778, timeflaw@konkuk.ac.kr

### Overview

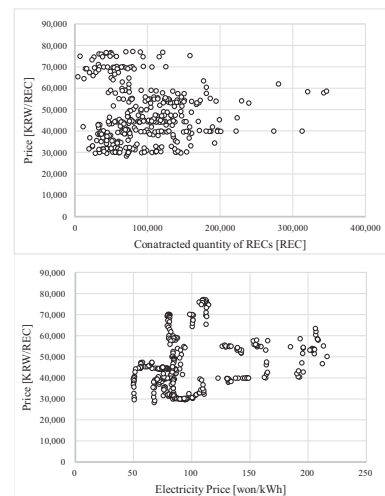
Korea's renewable energy dissemination policy has been implemented based on the Renewable Portfolio Standards (RPS) since 2012. In Korea, the obligatory target under the RPS is not for power distribution companies, but for power generation companies with generation facilities of 500 MW or more. As of 2022, 24 power generation companies are following the obligation. In 2022, the mandatory supply ratio is 12.5% of the previous year's base generation, which is about 58.7 TWh based on the thermal power generation and corresponds to 78.7 million Renewable Energy Certificates (RECs). The obligated supplier fulfills the obligation by procuring RECs through long-term contracts, self-constructions, and the REC spot market. The most important indicator in procurement of RECs is the REC spot price, which is determined by direct and indirect influences such as market shape, REC demand and supply, leveled cost of energies (LCOEs) of renewable generations, and electricity market price. Among them, the spot market was opened for the smooth fulfillment of the obligations of the supplier, and trades are conducted twice a week (Tuesday and Thursday). In this study, major factors affecting the REC spot market price were identified using AI-based statistical techniques targeting the Korean REC spot market, and the short-term REC price was predicted based on the model.

### Methods

The REC price can be theoretically estimated by subtracting the System Marginal Price (SMP) from the LCOE (Levelized Cost of Electricity) [1]. However, this estimation formula does not reflect the various policies and factors of the renewable business so the results may be distorted in real-world transactions. New REC spot market price estimation methods have been proposed to overcome this problem [2-4]. However, forecasting is difficult due to the correlation between the REC price and potential future business environments and policy changes. In this study, we propose REC spot market analysis models that comprehensively reflect the renewable energy industry environment and national policies in Korea's electricity ecosystem. The proposed models perform REC spot market simulations that comprehensively utilize various factors, including national energy and electricity policies, renewable energy plans, electricity markets, oil prices, and economic indicators such as exchange rates.

The main influencing factors of the simulation models are as follows:

1. REC spot market: AI-based statistical estimation
2. Electricity market: SMP estimation based on energy supply and demand
3. Renewable energy status: dissemination status and national renewable energy dissemination goal
4. REC selection contract: AI-based bidding, statistical patterns for transactions
5. National energy policy: policy direction, such as a change in supply obligation quota
6. Economic indicators such as oil prices and exchange rates: forecasts of indicators by national institutions



**Figure 1. Correlation between REC price, quantity and SMP**





Time series-based AI algorithms [5] can be used for short-term price estimation. We adopt a recursive estimation model to estimate the price for one month into the future and use the estimated price for training. We extend the short-term predictions beyond 12 months using a re-sampling methodology (Gibbs sampling and bootstrapping) and construct a simulation model based on the econometric model [6-7]. We use the Feature Permutation Importance Method [8] to analyze the importance of influence factors. The model is validated based on the minimum mean absolute error (MAE) between the actual and the estimated REC prices.

## Results

We trained a time series-based AI model to estimate short-term REC spot transaction volume and transaction amount using data up to March 2022, and tested the model on the next three months of data (from April to June 2022). Compared to the average, the resulting MAE volume and amount were 12.8% and 8.2%, respectively, which were relatively large errors compared to the average transaction volume and average transaction amount of the historical data. This suggests that interpreting the REC spot market only through trend analysis may cause distortion. Thus, it would be reasonable to develop and apply an AI-based in-depth model that heuristically reflects changes in policy goals.

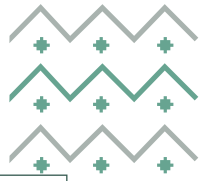
## Conclusions

The composite analysis conducted in this study uses a scenario-based comprehensive simulation model. Scenarios are established according to the order of importance of influencing factors and policy implications derived from past policy performance. In the simulation model, it is possible to provide not only future estimates of important factors, but also the predicted simulation results of the REC spot market in consideration of the characteristics such as renewable energy dissemination policies and changes in the electricity market and energy policy. Through this study, it is possible to analyze the impact of policy implications such as the renewable energy dissemination policies and RPS according to the scenarios. It is expected that the cause analysis will provide a basis for reflecting on the impact of new policies in the future.

## References

- [1] S. Y. Kim, S. Y. Park (2020), Long-Term Estimation for REC Price, TLG on 1(6) The Lantau Group.
- [2] C. Y. Lee (2015), Development and operation of price prediction methodology for REC Price of Renewal Energy, Basic Research Report 2015-12 Korea Energy Economics Institute.
- [3] J. Bryan et al. (2015), Estimating the Price of ROCs, The Electricity Journal, 28(1), 49-57.
- [4] M. Hustveit et al. (2017), Tradable green certificates for renewable support: The role of expectations and uncertainty, Energy, 141, 1717-1727.
- [5] C. Wang, M. Baratchi, T. Bäck, H. H. Hoos, S. Limmer, M. Olhofer(2022), Towards Time-Series Feature Engineering in Automated Machine Learning for Multi-Step-Ahead Forecasting, Engineering Proceedings. 18(17) 1-11.
- [6] D. J. Eck(2017), Bootstrapping for Multivariate Linear Regression Models, Statistics and Probability Letters 134.
- [7] A. B. Mantz(2016), A Gibbs sampler for Multivariate Linear Regression, Monthly Notices of the Royal Astronomical Society, 457(2) 1279-1288.
- [8] L. Breiman(2001), Random Forests, Machine Learning, 45(1), 5-32.





## ***UTILIZING SOLAR ENERGY IN THE 2<sup>nd</sup> INDUSTRIAL CITY LOCATED IN RIYADH, SAUDI ARABIA***

Nawwaf A. Althineyan  
Saudi Electricity Company  
Cell# +966531342591  
Email: [Nawwaf\\_p407@hotmail.com](mailto:Nawwaf_p407@hotmail.com)

### **Overview**

The use of renewable energy becomes essential for the economic and social progress of a country. The world faces two issues; finite reserves of nonrenewable energy and climate threats from conventional energy resources. Utilizing renewable energy resources is a solution to reduce energy costs and carbon dioxide emissions (CO<sub>2</sub>). Solar radiation in the Arabian Peninsula is a more affluent region compared to other regions. This fact helps to consider solar energy as an alternative energy source in the Kingdom of Saudi Arabia (KSA). Solar is a safe and sustainable resource and will create a solid potential to supply the industry field demands with sustainable and clean energy fully or partially.

This study will explore the electrical and thermal energy demand of the 2nd Industrial City in Riyadh, Saudi Arabia. Surveys will be conducted to collect the necessary data related to energy consumption and CO<sub>2</sub> emission in the 2nd Industrial City. Information related to available spaces in the 2nd industrial City to install needed renewable energy systems will also be collected. In this study, multiple factories from the 2nd Industrial City will be considered as case studies to obtain approximate results for the whole area.

The cost-effectiveness of utilizing solar energy systems will be investigated. A comparison will be conducted of solar and conventional energy systems. The study will pave the way and encourage solar energy utilization instead of conventional energy resources in Saudi factories. The study also will provide recommendations for factories' owners regarding the appropriate solar systems and locations to install the optimum systems.

### **Methods**

- Analyze the gathered information provided by different sources.
- Propose methods of supplying the industries with their energy needs (PV / Thermal).
- Calculate the saving cost from electricity or gas bills when installing solar applications in a large land next to a factory or factory roof upon the energy required.
- Compare whether a complete or partial replacement of solar energy usage in the industries or chosen industries are viable.
- Determine CO<sub>2</sub> saving in the 2nd industrial area when replacing solar energy instead of conventional energy resources.

### **Results**

The simulation is still under experiment and not yet finalized. However, there were previous studies which concluded results about solar radiation in Saudi Arabia. A comprehensive study with three different scenarios were conducted by Almarshoud [using the RETScreen software. The author investigated a photovoltaic system's performance in measuring solar irradiance at 32 locations in several cities across Saudi Arabia. Three tracker configurations of the photovoltaic system were evaluated: fixed tilting angle, 1-axis tracker, and 2-axis tracker configurations. The author employed RETScreen software to simulate the energy productivity for the evaluated locations. According to the results, the northern area of Saudi Arabia - especially in Tabuk - showed a higher energy generation due to the lower climate temperature. The same phenomena were observed in the southerly portion of Saudi Arabia - specifically at Najran and Sharourah - due to the high solar irradiance during the year. The highest energy produced by Solar panels in the Kingdom was located in Najran city, which produced; 218.5 MWh, 291 MWh, and 300.5 MWh for fixed tilting angle 1-axis tracker 2-axis tracker, respectively. The obtained results show that the produced energy using the 1-axis tracker configuration is 28–30% higher than the fixed tilting angle. However, the difference in energy produced by





the configuration of the 1-axis tracker and the configuration of the 2-axis tracker is 3–4.5%. Hence, it was concluded that installing a 1-axis tracking system is the best choice for solar tracking in Saudi Arabia for economic reasons.

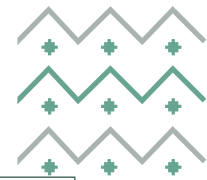
## Conclusions

TBA

## References

- [1] B. Koçak, A. I. Fernandez and H. Paksoy, "Review on sensible thermal energy storage for industrial solar applications," Elsevier Ltd., pp. 135-169, 2020.
- [2] E. Zell, S. Gasim, S. Wilcox, S. Katamoura, T. Stoffel, H. Shibli, J. Engel-Cox and M. Al Subie, "Assessment of solar radiation resources in Saudi Arabia," *Solar Energy* 119, pp. 422-438, 2015.
- [3] R. Ferroukhi, A. Khalid, D. Hawila, D. Nagpal, L. El-Katiri, V. Fthenakis and A. Al-Fara, "RENEWABLE ENERGY MARKET ANALYSIS THE GCC REGION," IRENA, p. 44, 2016.
- [4] J. L. Sawin, F. Sverrisson, K. Chawla, C. Lins, A. McCrone, E. Musolino, L. Riahi, R. Sims and J. Skeen, "RENEWABLES 2014 GLOBAL STATUS REPORT," RENEWABLE ENERGY POLICY NETWORK FOR THE 21st CENTURY, Paris, 2014.
- [5] F. Gruisic-Cabo, S. Nizetic and T. G. Marco, "Photovoltaic Panels: A review of the cooling techniques," *Transactions of FAMENA*, 2016.
- [6] Y. Wang, S. Zhou and H. Huo, "Cost and CO<sub>2</sub> reductions of solar photovoltaic power generation in China: Perspectives for 2020," *Energy Rev*, pp. 370-380, 2014.
- [7] W. Mtalaa, K. Amroun, M. AAL and R. Aggoune, "CO<sub>2</sub> emissions calculation models for green supply chain management," in *POMS 20th Annual Conference*, Orlando, 2009.
- [8] N. Y. Mansouri, R. J. Crookes and T. Korakianitis, "A projection of energy consumption and carbon dioxide emissions in the electricity sector for Saudi Arabia: The case for carbon capture and storage and solar photovoltaics," *Energy Policy*, pp. 681-695, 2013.
- [9] L. Kumar, M. Hasanuzzaman and N. A. Rahim, "Global advancement of solar thermal energy technologies for industrial process heat and its future prospects: A review," *Energy Conversion and Management*, no. www.elsevier.com/locate/enconman, pp. 885-908, 2019.
- [10] A. F. Almarshoud, "Performance of solar resources in Saudi Arabia," *Renewable and Sustainable Energy Reviews* 66, pp. 694-701, 2016.
- [11] S. Han and J. Kim, "A multi-period MILP model for the investment and design planning of a national-level complex renewable energy supply system," *Renewable Energy* 141, no. www.elsevier.com/locate/renene, pp. 736-750, 2019.
- [12] S. Munawwar and H. Ghedira, "A review of renewable energy and solar industry growth in the GCC region," *Energy Procedia* 57, no. 2013 ISES Solar World Congress, pp. 3191-3202, 2014.
- [13] S. S. Rashwan, A. M. Shaaban and F. Al-Suliman, "A comparative study of a small-scale solar PV power plant in Saudi Arabia," *Renewable and Sustainable Energy Reviews* 80, no. www.elsevier.com/locate/rsrer, pp. 313-318, 2017.
- [14] W. Matar and M. Anwer, "Jointly reforming the prices of industrial fuels and residential electricity in Saudi Arabia," *Energy Policy* 109, no. www.elsevier.com/locate/enpol, pp. 747-756, 2017.
- [15] H. Mahmood, T. T. Y. Alkhateeb, M. M. Z. Al-Qahtani, Z. Allam, N. Ahmad and M. Furqane, "Energy consumption, economic growth and pollution in Saudi Arabia," *Management Science Letters* 10, no. the Creative Commons Attribution, p. 979–984, 2020.





Renewables

## TECHNO-ECONOMIC ANALYSIS OF SOLAR-ASSISTED INTEGRATED ENERGY OPTIMIZATION SYSTEM FOR STEEL MAKING PLANTS LOCATED IN RAS AL-KHAIR INDUSTRIAL CITY

[Faisal Bader Almutairi, Engineer, 0561109333, faisal.almutairi.13@aramco.com]  
 [Ali Abdulaziz Ugla, Porfessor, 0509555599, ali.ugla@aramco.com]

### Overview

Steelmaking process is considered extremely energy-intensive and carbon-dependent processes. Electric Arc Furnace (EAF) is the most electricity consumer in the whole process that counts for approximately 35% of the total required energy. In addition to its huge energy consumption, it was estimated that the emissions from global steel production represented 7–9% of direct emissions generated by fossil fuels. The use of solar energy to power such systems may save a large amount of electrical energy. This paper evaluates on grid integrated energy supply using a techno-economic analysis. The purpose of this paper is to exploit the results achieved in the analysis to develop viable recommendations in utilizing solar energy to power such extensive energy consumption equipment in steelmaking plant to establish tangible economic benefits from applying such technology. The results show that on grid solar thermal system is economically feasible with over 100 GWh electrical energy annual saving that resulted in a plant operating cost saving of \$5 MM/year of 0.34 million ton/year of liquid steel production plant. Also, the system ensures a carbon emissions reduction of 15% and PBP of 8 years.

### Method

In order to provide a consistent baseline for comparison with the traditional energizing process, Table 1 shows the basis assumptions for the selected operation characteristics under analysis. This factory is selected to be located in Ras Alkhair industrial city, Saudi Arabia.

Table 1: Case Study Main Operating Parameters

Characteristic	Description	Unit
Capacity	340000	Ton
Power transformer	100	MVA
The specific energy consumption	359	Kwh/ton
Annual average of direct normal irradiance (DNI)	1900	Kwh/m2/year

### Technical Assessment Result

The applied off-gas data for the process design (mass flow and temperature) are examine. The fluctuation in mass flow and temperature of the off-gas between melting and charging (0:18–0:22) are obvious. During melting temperature, peaks of 1400 °C are reached. During charging the off-gas temperature decreases rapidly to 250 °C before the melting of the second scrap bucket starts (0:18–0:22). When the EAF lid is closed and the electric arc ignites the off-gas temperature increases dramatically again to 800 °C. As off-gas quenching is required in the reference plant off-gas waste heat will be just extracted at temperatures above 600 °C. About 600 °C is chosen to definitely ensure the mitigation of dioxin formation via de novo +synthesis. [13,14] Consequently, a waste heat extraction is potential to provide the system with its required energy in order to achieve the economical and environmental accomplishments.

### Payback Period Analysis

The economic analysis results show that the PBP for the energy optimization system is 8 years, demonstrating that the system will result in great environmental protection as well as utilizing free sources of energy. Table 3 summarizes the cost of components, total investments, and annual saving for the system. The result illustrates that the PBP results is directly impacted by the changing of electricity rates. As the electricity rate increases, the PBPs decrease.

Table 2: PBP at electricity rate of \$0.048/kW h.

Parameter	Rate	Unit
Inflation Rate	4%	-
Discount Rate	3%	-
Total Investment Cost	40,000,000	\$







Total Annual Saving	5,000,000	\$
Payback Period	8	Year

### Net Present Value Analysis

The results from this analysis shows that the NPV for the system is \$ 83,093,922 indicating that the system is feasible at the given electricity rate. The models demonstrate that the NPV becomes positive, indicating feasibility, at the electricity rate of \$0.048/kW h. The analyses by both NPV and PBP methodologies show that the system is economically viable and environmentally friendly in the eastern province of Saudi Arabia.

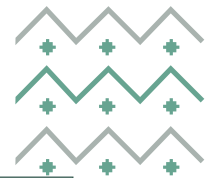
### Conclusions

The economic analyses using both PBP and NPV methods revealed that the solar thermal electric arc furnace and energy optimization system is economically feasible and environmentally friendly for steel industry. Moreover, the technical analysis reveals that the wasted heat and the solar thermal energy is sufficient to power the whole system. The eastern province of Saudi Arabia where most of the factories are located will benefit by applying such system in different highly temperature-based industries. However, the analytical results show that the energy optimization system is feasible and economically viable. The (PBP) for the system is 8 years. Furthermore, A solar-assisted integrated energy optimization system for EAF steelmaking was presented. Main process aspects are discussed using solar thermal energy, off gas data of steelmaking plant with a usable waste heat potential of 14.7 MWth. The system will achieve 100 GWh electrical energy saving annually and 15% reduction in estimated carbon emissions. Moreover, the system ensures 24 hours operation without interruption, full operation during maintenance times and Control automation system for energy supply management.

### References

- [1] Rahmonov I 2015 International Scientific-Practical Conference «Science and Innovation in the XXI century: problems and solutions (The United Kingdom: London) 22-5
- [2] Hoshimov F and Rahmonov I 2014 J. European Science review. B 11-12 56-9
- [3] Hoshimov F and Rahmonov I 2015 J. Austrian Journal of Technical and Natural Sciences. 3-4 52-5
- [4] Taslimov A 2013 J. Mining Herald of Uzbekistan. B 43 112-7.
- [5] Klyunya V 2006 Fundamentals of Economic Theory. 238
- [6] Koptsev L and Koptsev A 2011 J. Industrial energy. 1 18-23
- [7] Grinev A 2012 J. Industrial energy. 3 19-22
- [8] Kazarinova L, Barbasova T, Kolesnikova O and Zakharova A 2014 J. Computer technologies, management, electronics. 14 5–11
- [9] Kambezidis, H.D. Annual and seasonal trends of solar radiation in Athens, Greece. J. Sol. Energy Res. Updates 2018, 5, 14–24. [CrossRef]
- [10] Kambezidis, H.D. The solar radiation climate of Athens: Variations and tendencies in the period 1992–2017, the brightening era. Sol. Energy 2018, 173, 328–347. [CrossRef]
- [11] Kambezidis, H.D. The solar resource. In Comprehensive Renewable Energy; Sayigh, A., Ed.; Elsevier: Amsterdam, The Netherlands, 2012; pp. 27–83. ISBN 978-0-08087-872-0.
- [12] M. Kirschen, Energieeffizienz und Emissionen der Lichtbogenöfen in der Stahlindustrie, Verlag Stahleisen GmbH, Düsseldorf 2007.
- [13] T. Steinparzer, M. Haider, F. Zauner, G. Enickl, M. Michele-Naussed, A. C. Horn, Steel Res. Int. 2014, 85, 519. [3] M. Kirschen, V. Velikorodov, H. Pfeifer, Energy 2006, 31, 2926.
- [14] S. Lecompte, O. A. Oyewunmi, C. N. Markides, M. Lazova, A. Kaya, M. van den Broek, Energies 2017, 10, 649.
- [15] H. Schliephake, C. Born, R. Granderath, F. Memoli, J. Simmons, Iron Steel Technol. 2011, 8, 330.
- [16] T. Bause, F. Campana, L. Filippini, A. Foresti, N. Monti, T. Pelz, Iron Steel Technol. 2014, 1, 1101.
- [17] O. Rentz, S. Hähre, R. Jochum, J. Geldermann, M. Krippner, F. Schultmann, Exemplarische Untersuchung zum Stand der praktischen Umsetzung des integrierten Umweltschutzes in der Metallindustrie und Entwicklung von generellen Anforderungen, DFIU, Karlsruhe 1999.
- [18] T. Nussbauer, Dioxin- und PAK-Emissionen der privaten Abfallverbrennung; Umweltmaterialien Nr. 172, BUWAL, Bern 2004.
- [19] G. Hartfuß, M. Schmid, G. Scheffknecht, in Proc. 4th ESTAD, Steel Institute VDEh, Düsseldorf, Germany 2019
- [20] I. Barin, F. Sauert, Thermochemical Data of Pure Substances, VCH Verlagsgesellschaft, Weinheim 1989.
- [21] Y. A. Criado, M. Alonso, J. C. Abanades, Ind. Eng. Chem. Res. 2014, 53, 12594.
- [22] IFK, <https://www.ifk.uni-stuttgart.de/en/research/experimentalfacilities/pilot-scale-test-facilities/diva-elwira/>
- [23] A. C. Hoffmann, L. E. Stein, Gas Cyclones and Swirl Tubes – Principles, Design and Operation, Springer-Verlag, Berlin, Heidelberg 2008





## OPTIMAL SITE SELECTION FOR A SOLAR PV PLANTS IN SAUDI ARABIA

Dr. Hassan Z. Al Garni, Royal Commission for Jubail and Yanbu, Jubail Industrial College, +966543331315, [garnihz@gmail.com](mailto:garnihz@gmail.com),  
[garni\\_h@jic.edu.sa](mailto:garni_h@jic.edu.sa)

### Overview

Solar photovoltaic (PV) is growing at an extraordinary rate which brought the global total to approximately 942 GW by the end of 2021. Though, one of the barriers in solar power development is the inconsistency and variability of solar irradiation which can be geographically dissimilar from one site to another. To select a site for such an installation, certain aspects must be investigated, such as how good the PV power plant location is, and how to minimize the total cost of the project concerning proximity to existing infrastructures while maximizing power output from the solar panels. Site selection for the utility-scale photovoltaic (PV) solar farm is a critical issue due to its direct impact on the power performance, economic, environmental, social aspects, and existing as well as future infrastructures. Saudi Arabia has a high solar irradiation and is targeting to diversify the energy mix used in electricity generation by deploying more solar PV across the country and increase the share of renewable energy and natural gas to around 50% by 2030. The primary goal of this research is to evaluate and select the best location for utility-scale solar PV projects using geographical information systems (GIS) and a multi-criteria decision-making (MCDM) technique in Saudi Arabia.

### Methods

Given the fact that several criteria can influence the solar PV site selection, applying multiple criteria decision-making (MCDM) methods can help facilitate site selection for utility-scale grid-connected PV solar energy. MCDM methods have been successfully applied in many energy-planning projects. In recent years, the Geographical Information System (GIS) has become increasingly popular for various site selection studies, particularly for energy planning. Screening possible sites for PV projects is a prime strategic process as suggested by several studies and strategic organizations such as the National Renewable Energy Laboratory (NREL). The model considers different aspects, such as economic and technical factors, with the goal of assuring maximum power achievement while minimizing project cost. An analytical hierarchy process (AHP) is applied to weigh the criteria and compute a land suitability index (LSI) to evaluate potential sites.

### Results

Real climatology and legislation data, such as roads, mountains, and protected areas, are utilized in the model. The solar analyst tool in ArcGIS software is employed to calculate the solar insolation across the entire study area using actual atmospheric parameters. The air temperature map was created from real dispersed monitoring sensors across Saudi Arabia using interpolation. The overlaid result map showed that 16% (300,000 km<sup>2</sup>) of the study area is promising and suitable for deploying utility-size PV power plants while the most suitable areas to be in the north and northwest of the Saudi Arabia. It has been found that suitable lands are following the pattern of the approximate range of the proximity to main roads, transmission lines, and urban cities. More than 80% of the suitable areas had a moderate to high LSI.

### Conclusions

This research offers a high-level overview of the potential of site suitability of utility-scale PV technology in the study area based on integration of the geographical information system and multi-criteria decision-making tool. The AHP technique is used to evaluate the importance of each decision criterion in selecting the best site for utility scale solar PV power plants. Our study for Saudi Arabia case indicates that most suitable areas are found north and northwest of the study area as well as west of Taif city near the west coast. High suitability areas comprise 50% of the suitability areas and are mainly spread around the central region. This location will be important to consider for grid connected utility-scale PV power plants since it is one of the most populated areas in Saudi Arabia. The eastern region of the study area shows moderate to high LSIs since it has a decent infrastructure together with the high density of high solar irradiation.





## **[OPTIMAL DESIGN AND SCHEDULING OF A GRID-CONNECTED PV/CHP HYBRID SYSTEM WITH INCENTIVE-BASED DEMAND RESPONSE AND ELECTRIC VEHICLES: A CASE STUDY OF A MULTI-RESIDENTIAL COMPLEX BUILDING]**

[Mohamed R. Elkadeem, Interdisciplinary Research Center of Renewable Energy and Power Systems (IRC-REPS), King Fahd University of Petroleum and Minerals (KFUPM), Dhahran, Saudi Arabia, +20 1203947561, [mohammad.elkadim@f-eng.tanta.edu.eg](mailto:mohammad.elkadim@f-eng.tanta.edu.eg) ]

[Mohamed A. Abido, Interdisciplinary Research Center of Renewable Energy and Power Systems (IRC-REPS), King Fahd University of Petroleum and Minerals (KFUPM), Dhahran, Saudi Arabia, +966 508757838, [mabido@kfupm.edu.sa](mailto:mabido@kfupm.edu.sa)]

[Fahad Al-Sulaiman, Interdisciplinary Research Center of Renewable Energy and Power Systems (IRC-REPS), King Fahd University of Petroleum and Minerals (KFUPM), Dhahran, Saudi Arabia, +966 508757838, [fahadas@kfupm.edu.sa](mailto:fahadas@kfupm.edu.sa)]

### **Overview**

The global overpopulation, fast urbanization, and large use of fossil fuels-based centralized power plants are the main sources of carbon emissions and temperature rise in cities [1]. Due to the rising demand for energy services in residential buildings for lighting, appliances, cooking, and heating, it share 17% of the global energy-related CO<sub>2</sub> emissions by sector in 2020 [2]. Besides, the global transport sector was responsible for 23% of CO<sub>2</sub> emissions in the same year. This alarming situation urged utilities and policymakers, to establish alternative solutions for climate change mitigation through the employment of renewable generation sources, energy efficiency measures, and electric vehicles [3],[4]. This is to enforce environmental preservation and eradicate the people's concerns about the energy crisis. Today, integrated hybrid energy systems (iHESs) have gained traction as a viable solution for mixing renewable (e.g., solar photovoltaic (PV) and wind turbine (WT)), and non-renewable (e.g., diesel generator, combined heat and power (CHP) microturbine) distributed generation sources [5]. iHESs could offer a path for affordable and sustainable energy as well as fulfill the desire for a reliable and resilient supply of the building sector [6]. On the other side, the ongoing technological innovations and the growing adoption of information, and communication infrastructures have rapidly increased the active participation of energy customers under demand response program (DRP) [14]. DRP, as one of the approaches to implement demand-side management, allows for a better interaction mechanism and balances supply and demand by incentivizing and benefiting customers to shift or curtail their consumption during on-peak hours according to contractual obligations with the grid operator [15]. This can stretch the capacity and reliability of the grid during most stressed periods and manage the intermittency of renewable resources, reduce the electricity cost and emission rate [16]. Different studies have been presented in the literature on the modeling of DRP techniques and objectives including time-based DRP, and incentive-based DRP in the context of the hybrid energy system as recently reviewed in detail by Imani et al.[17] and Ibrahim et al.[18].

### **Methods**

This paper proposes a methodology for optimal design and scheduling of a hybrid grid-connected iHES comprising roof-top PV, CHP microturbine, boiler and inverter considering private/shared EV charging stations, incentive-based DR program, and net metering mechanism (NEM). Different alternatives for system configuration are optimized and analyzed in terms of cost, emission, and resiliency metrics. A representative case study of a multi-residential complex building with electrical and thermal loads, located in Al-Mostakbal city, New Cairo (Egypt) is applied to validate the established methodology. The research method framework has two main stages. The first stage includes walkthrough data analysis to assess the site solar resource, fuel availability, electricity and heat consumption profiles of the building, specification and charging pattern of EVs, cost and technical data of PV and CHP, and grid parameters. The second stage involves the methodology approach adopted for the design optimization of the proposed iHES. The second stage is accomplished with the aid of HelioScope and HOMER GRID tools. Using HelioScope, the 3D model of building geometry including orientation, height, roof dimensions, slope, parapet walls, and other structural/ services obstacles is created and then the number and arrangements of PV modules as well as the inter-row distance are optimized. After that HOMER GRID is used as a reliable platform for modeling and optimization of the proposed iHES. In this stage, models of the system's elements including PV, CHP, EV, grid, boiler, inverter, and DRP are established. Then, the peak demand limits and the component sizes are optimized, to find the least-cost system under the so-called peak shaving approach. Furthermore, under the adopted incentive-DRPs for summer and winter seasons, in which customers voluntarily curtail their consumption during specific conservation periods (DRP events) in response to a financial signal from the grid operator, the algorithm optimizes demand reduction bid during each DRP event to maximize the revenue. The adopted dispatch strategy features the ability two days look-ahead to know the electric demand, PV production, and grid tariff for each time step in the future to avoid any capacity shortage whenever possible. Once all feasible systems are investigated, the system with the least net present cost (NPC) and levelized cost of energy (LCOE) is nominated as the winning design.

### **Results**

In this paper, the results are analyzed and discussed from the perspective of three scenarios, including (i) Scenario 1 (base): iHES with Grid/Boiler only, in which the grid is responsible for maintaining the electricity



demand of the building apartments and EV charging demand, while the boiler is the source of the thermal power for water and space heating of the building apartments, (ii) Scenario 2: iHES with Grid/PV/CHP/Inverter/Boiler without DRP, (iii) Scenario 3: iHES with Grid/PV/CHP/Inverter/Boiler with DRP. Fig.1 shows the demand profiles for the different load types of the complex building under study. Based on the findings of the HelioScope, the maximum allowable capacity of the roof-top PV array is found 86.9 kW and consists of 161 fixed tilt modules of JKM540M-72HL4-TV type, with each having a rated power of 530W and efficiency of 20.94%. Fig. 2 shows the mounting and arrangement of the PV modules for the complex building under study. For design optimization of the proposed iHES, Table 1 summarizes the component sizes, cost, emission, and technical performance results for the three studied scenarios. The results show that the full utilization of the building roof with maximum PV capacity and adoption of the DRP incentives for both summer and winter seasons reduces the electricity import from the grid and encouraged the use of the on-site generation CHP microturbine. The optimal design with 86.9 kW PV, 100 CHP, and 100 kW inverter is of superior performance with the least NPC (476,878 \$) and LCOE (\$0.0513 \$/kWh), and considerable bill savings (28,248 \$/yr) when compared to the other two scenarios as shown in Table1. The winning alternative also comes with a significant reduction in CO<sub>2</sub> emission of 312092 kg/yr (21% less than the base scenario) and zero unmet electrical, thermal, and charging demands despite the grid outages.

Table 1 Results of optimized configurations with the studied iHES scenarios

iHES	Optimal size				EV results Peak demand (missed session) kW (session/day)	Grid results					NPC \$	LCOE \$/kWh	Unmet demand kWh/yr	CO <sub>2</sub> emission Kg/yr	
	PV kW	CHP kW	Inverter kW	Boiler production kWh/yr		Energy purchased kWh/yr	Energy sold kWh/yr	Peak load kW	Energy charge \$/yr	DRP revenue \$/yr					bill saving \$/yr
#1	-	-	-	134,320	83.2 (0.2)	573,242	-	181	39,662	-	-	610,005	0.0692	299	393,346
#2	86.9	-	100	134,320	83.2 (0.2)	443,098	19,657	181	29,522	-	10,140	540,988	0.0590	236	311,095
#3	86.9	100	100	110,744	0.2	277,719	19,668	169	\$18,079	\$6,665	28,248	474,172	0.0513	0	310,092

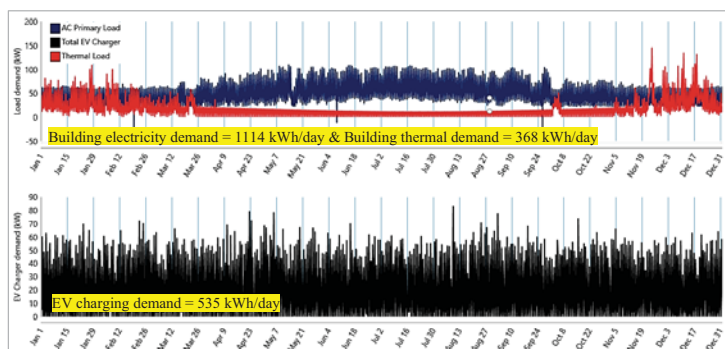


Fig. 1 Annual load profile for electrical, thermal, and EV demands



Fig. 2 The designed roof-top PV system

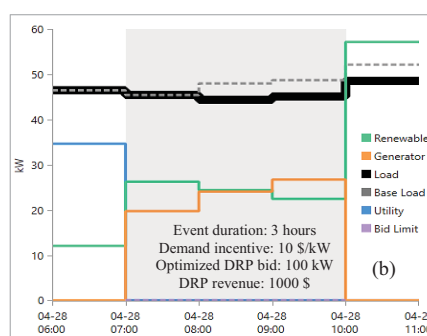
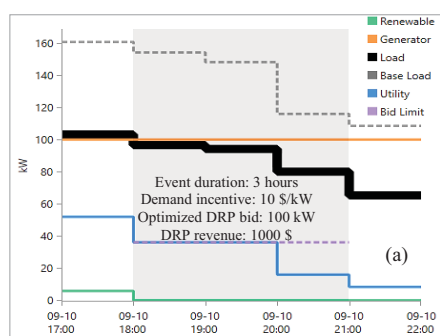


Fig. 3. Illustration of energy scheduling under incentive DRP in case of optimal design (scenario#3) (a) Sumer event on 10<sup>th</sup> September (b) Winter event on 28<sup>th</sup> April

### Conclusions

The proposed method for design and scheduling of iHES shows that hybrid utilization of roof-top solar PV and CHP showed evidence of being promising contributors to cost savings and decarbonized energy supply for complex buildings equipped with electrical, thermal, and EV charging demands. The implementation of incentive-based DRP, as well as NMM, allows for exploit of demand flexibility and on-site generation sources to minimize the grid bill and supply resiliency despite the intermittent nature of solar resources. The optimized iHES based on PV/CHP/grid has reduced the system NPC, LCOE, and CO<sub>2</sub> by around 22%, 26%, and 27% compared to the base scenario with grid/boiler and by 14%, 15%, and 0.3% compared to the second scenario with PV/grid/boiler, respectively. Also, the winning system can boost customer satisfaction and provide redundancy of reliable, even power during power outages.





## ***GREEN HYDROGEN: A KEY POWER FOR THE ENERGY TRANSITION***

### ***Egypt National Strategy of Hydrogen***

AMAL ISMAIL, NEW & RENEWABLE ENERGY AUTHORITY,01068148721,amalismail523@

#### **Abstract**

Hydrogen has the potential to be a powerful enabler of the Global Energy Transition, as it offers a clean, sustainable and flexible option for overcoming multiple obstacles that stand in the way of a resilient and low-carbon economy, in addition to significant promise to help meet global energy demand while contributing to climate action goals.

The demand for hydrogen reached an estimated 87 million metric tons (MT) in 2020, and is expected to grow to 500–680 million MT by 2050. From 2020 to 2021, the hydrogen production market was valued at \$130 billion and is estimated to grow up to 9.2% per year through 2030. But there's a catch: over 95% of current hydrogen production is fossil-fuel based, very little of it is "green". Today, 6% of global natural gas and 2% of global coal go into hydrogen production.

Nevertheless, green hydrogen production technologies are seeing a renewed wave of interest. This is because possible uses for hydrogen are expanding across multiple sectors including power generation, manufacturing processes in industries such as steelmaking and cement production, fuel cells for electric vehicles, heavy transport such as shipping, green ammonia production for fertilizers, cleaning products, refrigeration, and electricity grid stabilization.

The global hydrogen market is picking up speed and for good reason. Hydrogen will play an important role as an energy carrier, which enables the transfer of energy from areas where renewables such as wind and solar are abundantly available and with low cost to another.

In this paper we explore the role of hydrogen in the energy transition, including its potential in different sectors, recent achievements, and challenges to its deployment. We also show the Egyptian potential for Hydrogen in the region and how it can be one of the hydrogen market leaders.

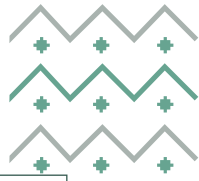
#### **The role of hydrogen in a 1.5°C scenario**

A sustainable energy system based on renewables will massively change the political structures of the world. Something that may be good for the global climate, and could lead to serious geopolitical upheavals and help decarbonization of the global economy. The report of IRENA 2022a shows that a combination of renewables in the electricity system, electrification of end-use and energy efficiency. In the 1.5°C scenario of the World Energy Transitions are expected to achieve 70% of the carbon dioxide (CO<sub>2</sub>) reduction towards 2050.

Hydrogen is expected to satisfy 12% of final energy demand and contribute to a reduction of 10% of the total CO<sub>2</sub> emissions in this 1.5°C scenario, which together with carbon capture and storage (CCS) and negative emission technologies paves the way for achieving a net-zero emissions energy system.

In a decarbonised energy system, as new applications become necessary, the total hydrogen production is expected to expand by almost five times, to 614 Mth<sub>2</sub>/year, to satisfy 12% of the final energy demand by 2050 in a 1.5°C scenario. This is driven by growth in the industrial and transportation sectors, where hydrogen mitigates close to 12% and 26% of the CO<sub>2</sub> emissions, respectively. To achieve this growth, focus on hydrogen should be broader.





transformation also takes place on the supply side, where the production shifts from being fossil-based to reach two-thirds being generated with renewable electricity (green hydrogen) and one-third from fossil fuels with CCS (blue hydrogen), another emerging pathway is methane pyrolysis (turquoise hydrogen)

## Hydrogen Global Trade

The potential opportunities for global trade are driven in part by the cost differential over time between domestic production and imports. Each of these components can be further broken down into their fundamental drivers. Two of the key drivers are how the CAPEX and weighted average cost of capital (WACC) evolve over time.

The analysis is based on variable renewable energy technologies: solar PV, onshore wind and offshore wind. These technologies have experienced a 55-85% decrease in costs over the last decade, and their global capacity will increase by at least an order of magnitude in a 1.5°C scenario.

## Conclusion

According to IRENA analysis, For large-scale hydrogen production and trade to be a viable component of the 1.5°C scenario, the electricity used to produce the hydrogen must not detract from the availability of electricity for other essential and more effective uses – it must be additional. This places the upscaling and acceleration of renewable energy generation at the heart of the transition to green hydrogen. The production of renewable energy needs to at least triple from today's 290 gigawatts (GW) per year to more than 1 terawatt (TW) per year by the mid-2030s. Over 10 000 GW of wind and solar power would be needed by 2050, just for green hydrogen production and trade.

Egypt planning to become one of the key factors for the hydrogen market aiming to have around 5% of the global hydrogen market, with more than 8 projects under development.





### ***Energy Efficiency Initiatives towards Sustainability on University Campuses in Saudi Arabia***

[Saleh Albadaily, Department of Electrical Engineering, College of Engineering, Imam Mohammad Ibn Saud Islamic University, Riyadh, Saudi Arabia, [saaalbudaily@sm.imamu.edu.sa](mailto:saaalbudaily@sm.imamu.edu.sa)]

[Abdullah Alhaqbani, Department of Electrical Engineering, College of Engineering, Imam Mohammad Ibn Saud Islamic University, Riyadh, Saudi Arabia, [ansalhaqbani@sm.imamu.edu.sa](mailto:ansalhaqbani@sm.imamu.edu.sa)]

[Walied Alfraidi, Department of Electrical Engineering, College of Engineering, Imam Mohammad Ibn Saud Islamic University, [walfraidi@imamu.edu.sa](mailto:walfraidi@imamu.edu.sa)]

#### **Overview**

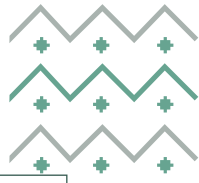
A significant share of electricity from renewable resources has been mandatory to reduce greenhouse gas emissions released from burning fossil fuels, and to de-carbonize the electricity sector. With the evolution of smart grids and microgrids, effective and efficient penetration of renewable generation such as wind and solar can possibly be attained. The concept of Microgrids has been introduced in the distribution network to obtain a reliable and stable use of distributed energy resources (DERs), and distinguish between a large power network and a group of DERs located next to each other, which can be seen as a single generator or loads. A microgrid can be defined as a self-sufficient energy system that includes one or more kinds of DERs (solar panels, wind turbines, combined heat & power, generators) to produce power and serves a discrete geographic footprint, such as a university campus.

The Kingdom of Saudi Arabia recognizes the importance of diversified energy mix to its long-term economic prosperity. The Ministry of Energy, through the National Renewable Energy Program, has therefore pledged a commitment to the deployment of renewable energy to meet electricity demand growth. On the other hand, the electricity sector in the Kingdom of Saudi Arabia is one of the largest in the Arab Gulf region, and its peak demand increased from 35 GW in 2007 to 61.7 GW in 2018, with an average 5.31% annual increase in demand between 2007-2018. In order to advance and improve energy efficiency services in the Kingdom and to tackle rising energy consumptions in existing buildings and facilities, the National Energy Services Company (Tarshid) was recently established by the Public Investment Fund. It is a result of a collaborative effort between the Ministry of Energy, Ministry of Finance and the Saudi Energy Efficiency Centre, for creating robust energy efficiency solutions in the Kingdom. Tarshid has set ambitious targets for implementing energy efficiency projects in buildings and facilities across the Kingdom. For instance, it has launched a retrofit project to increase the energy efficiency and reduce the consumption in the buildings of Imam Mohammad ibn Saud Islamic University (IMSIU) in Riyadh, with an estimated annual reduction of 43% in a targeted annual energy consumption of 229 GWh.

The IMSIU main campus consists of 255 buildings in Riyadh, and that consumes an annual energy of 414 GWh. Such energy consumptions annually account to about 270 thousand tons of greenhouse gas emissions released from burning fossil fuels. Indeed, there is a need to create a sustainable and energy efficient campus buildings by relying on renewable energy systems as a main source of power, such as a hybrid solar energy system (HSES), in supplying the campus' electricity needs. This will make the university campus more in line with Saudi Vision 2030 in energy and sustainability by having energy conservations and increasing the contribution of renewable energy to the overall energy. Nevertheless, an annual demand of the campus is about 48 MW, and that requires an installation of a very large capacity of the HSES, leading to a high financial burden and large installation area. It is therefore essential to reduce the energy consumption of the campus buildings through improvement of the buildings energy efficiency, by retrofitting the building components, which is identified as the most promising in synergy with hybrid solar energy systems. This is because building renovation allows reducing both the required installed solar energy system and storage capacity used in supplying campus loads. This paper presents the development of an energy management model which considers the features of campus microgrid for the IMSIU, including interrelationships between various entities such as a rooftop photovoltaic (PV) generation, battery energy storage system (BESS), demand response and the utility. The model also considers the retrofit project implemented by Tarshid at IMSIU, for increasing energy efficiency and reducing the energy consumptions in the IMSIU buildings. The primary objective of this paper is to investigate to what extent the building retrofit can maximize building energy efficiency while reducing the installed capacity of a HSES and the total cost of a campus microgrid for the IMSIU.

#### **Methods**

A mathematical optimization model is developed for optimal design and planning of a campus microgrid for the IMSIU. The developed model that includes a rooftop photovoltaic (PV) generation, battery energy storage system, and demand response capabilities can be used to analyze the effects of buildings retrofit on the campus loads as well as the installed capacity of the HSES for a campus microgrid. Moreover, this model investigates the impact of increasing energy efficiency on the level of penetration of renewable generation in campus microgrid.



The objective function is to minimize the total cost (TC) of the campus microgrid using its local generation resources and importing /exporting power from /to the distribution grid.

$$TC = CC^E Esize^{bess} + CC^P Psize^{bess} + CC^{PV} Psize^{PV} + \sum_{h \in H} (P_h^{Im} \times C_h^{grid}) - \sum_{h \in H} (P_h^{Ex} \times C_h^{grid}) \quad (1)$$

The first three terms of (1) are associated with the capital cost of installed capacity of the HSES, while the last two terms of (1) are the cost for importing and exporting power from/to the distribution grid, respectively.

*Energy Management Equation of Campus Microgrid:* This constraint ensures that the total generation meets the forecasted campus load of period  $h$ , and includes PV generation, BESS, power import and export from/ to the distribution grid.

$$Psize^{Pv} \beta_h^{Pv} + P_h^{Disc} + P_h^{Im} = Pd_h + P_h^{ch} + P_h^{Ex} \quad (2)$$

In order not to receive and send power from/to the main grid at the same hour  $h$ , the following constraint is included into the model.

$$P_h^{Im} \cdot P_h^{Ex} = 0 \quad (3)$$

*HSES Equations:* The HSES should satisfy the following constraints:

$$\text{Discharge/ charging power limits:} \quad P_h^{disc} \leq Psize^{bess} \quad ; \quad P_h^{ch} \leq Psize^{bess} \quad (4)$$

$$\text{State of charge equation:} \quad C(h+1) = C(h) - d_h \cdot P_h^{disc} / \eta_d + d_h \cdot P_h^{ch} \eta_c \quad (5)$$

$$\text{Initial/Ending limits:} \quad C(0) = 0.5 Esize^{bess} \quad ; \quad C(H) = 0.5 Esize^{bess} \quad (6)$$

$$\text{Stored Energy limits:} \quad C_{min} \leq C(h) \leq Esize^{bess} \quad (7)$$

$$\text{Coordination of Charging/discharging power:} \quad P_h^{disc} \cdot P_h^{ch} = 0 \quad (8)$$

The above proposed mathematical optimization model is a nonlinear programming problem, and solved using the MINOS solver in General Algebraic Modeling System environment.

## Expected Results

Business models for microgrids rely on many factors, such as energy cost savings, improved reliability, and the amenity value of self-supply. The focus of our work on economic costs and benefits of self-supply which are the core of any commercial proposition. In this paper, we will model the business case for local energy provision, in which a Saudi university adopts a microgrid to self-generate electricity partially or fully to supply its own load and possibly provide energy to the main grid. This business case also seeks to address whether there is a need for incentives to motivate the university in transforming its campus to the microgrid that includes renewable energy, demand response capabilities, energy storage systems, and/or electric vehicles smart charging, so that the energy sector will be in line with the general objective of Saudi Vision 2030, which aims to diversify the Saudi economy away from oil. The expected results of the proposed research are summarized as follows: 1) Prior to the implementation of a campus microgrid for a Saudi university, several studies and analysis will be carried out to estimate and forecast the load profiles, identify a suitable network configuration, and selecting proper generation and storage units for a campus microgrid. 2) an investment support tool will be built for assessing business models in determining whether it is beneficial for the Saudi university to transform its campus to a microgrid.

## Conclusions

Energy efficiency initiatives implemented by Tarshid in the KSA is a key factor in transforming a university campus to a microgrid, that offers a Saudi university a way to keep critical electricity flowing during power outages, increase use of renewable energy, and better optimize energy supplies and campus loads. It can also be used as an educational and sustainability awareness tool, connecting technology to students and community. On the other hand, pairing energy storage, renewable energy, and advanced controls, in the context of a smart building, creates possibilities to better manage building energy use, save money and generate income while supporting the grid. The expected research outcomes are in the line with the National Industrial Development and Logistics Program that aims at increasing the share of the renewable energy sector in local consumptions, improving the competitiveness of the electricity sector through restructuring and exploring power exportation opportunities, and enhancing power supplies and prices. The university campus microgrid includes self-sustaining electricity infrastructure, an intelligent distribution system and system controllers, onsite electricity production, demand-response capability, and sustainable energy systems. The adoption of campus microgrids will make the energy sector in line with the general objective of Saudi Vision 2030, that aims to diversify the Saudi economy away from oil.



## ***TECHNO-ECONOMIC ANALYSIS OF GREEN HYDROGEN SYSTEMS BASED ON PHOTOVOLTAIC ENERGY TO GUARANTEE ELECTRICITY FEEDING IN OFF-GRID ENVIRONMENT- CASE STUDY***

Younes FAYDI, MASEN R&D - Morocco, (+ 212) 5 37 57 45 50, [y.faydi@masen.ma](mailto:y.faydi@masen.ma)  
Hichame Laabassi, MASEN R&D - - Morocco, (+ 212) 5 37 57 45 50, [h.laabassi@masen.ma](mailto:h.laabassi@masen.ma)  
Hicham BOUZEKRI, MASEN R&D – Morocco, (+ 212) 5 37 57 45 50, [h.bouzekri@masen.ma](mailto:h.bouzekri@masen.ma)

### **Overview**

In many African rural areas, villages are far from the central grid [1]. The access to electricity is made essentially by Diesel Gen. It could be a competitive option but regarding environmental aspects, the high carbon dioxide emissions led to a considerable environmental cost. Thus, minigrids composed from renewable resources are promising solutions and could be cheaper than Diesel Gen especially in sunny areas [2]. The challenge is to store energy for nights and cloudy days from overproduction of solar energy to guarantee the demand of electricity. Batteries are the most used technologies for storage, but it is not efficient for long storage duration. Thus, hydrogen could be a more reliable solution. Green Hydrogen is produced from Renewable Energy Sources (RES) and water through electrolyser whilst a fuel cell realizes the reverse process and produces electric power when needed.

Solid Oxide Cells (SoC) know an increasing industrial interest. Thanks to its high operating temperature (650 – 1000 °C), SOC have the highest efficiency between 88% and 96% for electrolysis mode and 56% for fuel cell mode [3].

In the present study, a techno-economic comparison between hybrid solutions based on Photovoltaic energy (PV) is made. The objective is to remove the use of Diesel fuel to power the total load of a hospital in Nigeria and guarantee the feeding. Beside batteries, Solid Oxide Cells (SoC) are evaluated to store the energy from PV in the form of Hydrogen (Electrolysis unit) and reversed it into electricity (Fuel cell unit) when needed. This paper shows the potential contribution of PV/SoC with a long-term hydrogen storage in areas with seasonality.

### **Methods**

The clinic is located in the region of Maiduguri. The Global Horizontal Irradiance (GHI) is about 2264 kWh/m<sup>2</sup> per year, which leads to a high photovoltaic power potential around 1753 kWh/kWp per year. However, the weather in Nigeria is changing from region to another and from season to another. In Maiduguri, located in the Northeast, the rainy season in the country occurs from March to September with prolonged rains from May to August. The dry season takes part on the remaining months of the year.

To get closer to the reality of the climate of the studied area, a Typical Meteorological Year is considered. It is a set of meteorological data (like GHI) with values for each hour in a year for a determinate geographical location. The data is extracted in a longer period (10 years or more). In this case it is from 2006 to 2017.

The study uses a simplified approach based on hourly load for one day repeated for each day along the whole year. The total day load is equal to 379.15 kWh. Four systems are compared. The reference scenario consists in the exclusive use of Diesel fuel followed by PV/Battery, PV/Hydrogen and PV/Battery/Hydrogen. The software Calliope ensures the design optimization and power dispatch to satisfy the full load profile. The Key parameters indicators are the initial investment, the levelized cost of energy and the PV savings.

### **Results**

When only diesel Genset is employed, the variation of Diesel price has a direct impact on the cost of electricity. For instance, the levelized cost of electricity, for the present case study, vary respectively from 0.15 \$/kWh to nearly 0.4 \$/kWh when the diesel price moves from 0.5 \$/L to 1 \$/L. This shows how far the diesel could be an economically bad solution due to its fluctuation. For instance, in September 2022, due to the Ukrainian crisis, the diesel price reached 1.77 \$/L.

The initial investment of the system PV/Battery is respectively 20% more expensive than PV/Battery/Hydrogen (Figure) because the system PV/Battery cannot store energy for a long-term and must be oversized to satisfy the load demand in cloudy days. For the system PV/Hydrogen, the storage of hydrogen is uncoupled to the unit that





produces it and the storage component is less expensive than Li-ion battery and could serve anytime when needed. However, the highness price of the solid oxide fuel cell (4630\$/kW) increase the total initial investment. This technology is still under development and its price will probably decrease in the next years. So, with hydrogen, it is possible to store the whole overproduction of the primary source and use it for nights and in rainy days but still need to be more competitive.

On the other hand, the combination of battery and hydrogen is an effective way to fully satisfy the load with the cheapest initial investment. In this configuration the battery storage is used for the daily loading/unloading cycles and hydrogen comes as a seasonal storage back-up when the primary source is insufficient, and the battery is unloaded even for few days.

In terms of LCOE, the system PV/Battery/Hydrogen has the lowest value (0.28 \$/kWh) where for the system PV/Battery the LCOE equals to 0.34 \$/kWh. PV/Battery/Hydrogen has a better management of PV energy that leads to reduce its lost, raise the PV savings and optimize the design of the PV. In the other side, the highest LCOE comes from the Diesel Genset (0.39\$/kWh) essentially due to the price of diesel fuel.

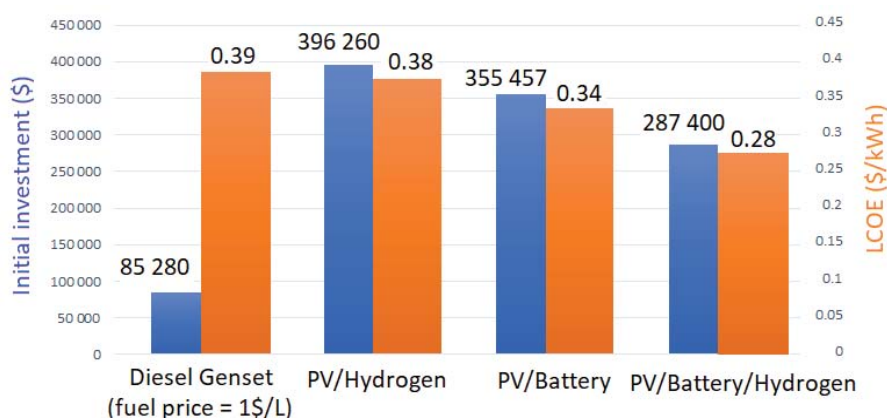


Figure: Variation of the initial investment and LCOE according to studied scenarios

## Conclusions

The present case study demonstrates the add value of hydrogen for microgrid to ensure a continuum feeding of electricity in regions that are far from the grid for desert regions such as north Nigeria. The solid oxide cells (SoC) technologies bring to the PV system or PV/Battery system an assurance of a long-term storage and allows a better managing of the PV energy produced. The results also show that adding the hydrogen vector allows an alternative net CO<sub>2</sub> emission to the current diesel genset powered microgrid over the operating life of the project.

## References

- [1] Africa Energy Outlook 2019. World Energy Outlook special report International - Country report. International Energy Agency (IEA) November 2019 < <https://www.iea.org/reports/africa-energy-outlook-2019>
- [2] Cader C, Bertheau P, Blechinger P, Huyskens, Breyer Ch. Global cost advantages of autonomous solar-battery-diesel systems compared to diesel-only systems. Energy for Sustainable Development 31 2016 14-23. <http://dx.doi.org/10.1016/j.esd.2015.12.007>
- [3] Bianchi F.R, Bosio B. Operating Principles, Performance and Technology Readiness Level of Reversible Solid Oxide Cells. Sustainability 2021. 13, 4777. <https://doi.org/10.3390/su13094777>



## ***DEVELOPMENT OF ALL-SOLID-STATE LITHIUM METAL BATTERIES FOR HIGH TEMPERATURE APPLICATIONS***

**Firoz Khan,**

Interdisciplinary Research Centre in Renewable Energy and Power Systems, King Fahd University of Petroleum & Minerals, Dhahran 31261, Saudi Arabia, +966138607019, [firoz.khan@kfupm.edu.sa](mailto:firoz.khan@kfupm.edu.sa)

**Hasan Jamal,**

Division of Energy Technology, Daegu Gyeongbuk Institute of Science & Technology, 333, Techno Jungang-Daero, Hyeonpung-Myeon, Dalseong-Gun, Daegu 42988, Republic of Korea., +82537853610, [hasanjamal@dgist.ac.kr](mailto:hasanjamal@dgist.ac.kr)

**M. Abdul Majid,**

Mathematical Sciences Department, Dammam Community College, King Fahd University of Petroleum & Minerals, Dhahran-31261, Saudi Arabia

Interdisciplinary Research Centre in Renewable Energy and Power Systems, King Fahd University of Petroleum & Minerals, Dhahran 31261, Saudi Arabia, +966138601184, [abdulmajid@dcc.kfupm.edu.sa](mailto:abdulmajid@dcc.kfupm.edu.sa)

**Jae Hyun Kim,**

Division of Energy Technology, Daegu Gyeongbuk Institute of Science & Technology, 333, Techno Jungang-Daero, Hyeonpung-Myeon, Dalseong-Gun, Daegu 42988, Republic of Korea., +82537853610, [jaehyun@dgist.ac.kr](mailto:jaehyun@dgist.ac.kr)

### **Overview**

The demand for high-energy storage devices has exponentially increased globally. Saudi Arabia which covers almost 1/3rd of the Arabian Peninsula, a vast open land, has abundant natural renewable energy resources. With the diversification of its economy and a shift toward clean energy sources, there is a sharp increase in demand for high-energy storage. All-solid-state lithium metal batteries (SLMBs) provide immense potential as a solution to this pressing demand. The material that is key in the development of high-performance batteries as well as providing long-term cycling permanency is the solid-state electrolyte; an ionic conductor and electron-insulating material. In order to achieve both high performance and increased lifetime, ceramic filler was employed for synthesizing a solid composite polymer (CPE). This process produces a stable interfacial layer between the polymer solid electrolyte and lithium anode, which prevents the formation of lithium whiskers. The galvanostatic lithium plating and stripping results revealed a stable interface between CPE and lithium metal for 375 h. The SLMBs show excellent performance for 200 cycles.

### **Methods**

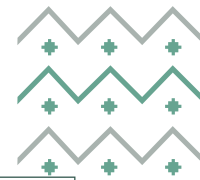
For the synthesis of polymer-based solid electrolyte, Lithium bis(fluorosulfonyl)imide (LiTFSI), and ceramic filler were dispersed together in Acetonitrile (ACN) solvent. A homogeneous solution was magnetic stirred at 1000 rpm for 24 h to get a mixture of LiTFSI and filler. Then polyethylene oxide (PEO) was slowly inserted into this mixture solution followed by stirring at room temperature. Furthermore, the solvent was added more and ball-milled for 48 h. The composite solution was used for the synthesis of CPEs by pouring the solution into a Teflon petri dish. It was dried in a nitrogen environment at room temperature. Then the samples were heat treated at 60 °C for 24 h to obtain a polymer membrane. The full cells were constructed using LiFePO<sub>4</sub> (LFP)-based cathode and lithium metal anode. The electrochemical characterizations were performed at 60 °C. The symmetric cell structure [Li|YNa-CPE|Li] was used for lithium plating and stripping (GLPS), whereas, the full cell was evaluated using structure [LFP|YNa-CPE|Li].

### **Results**

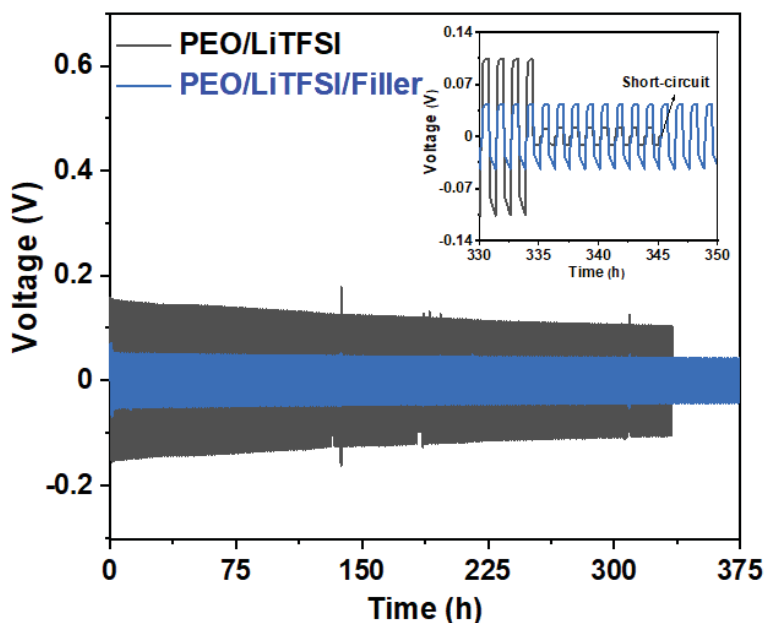
The GLPS profiles are illustrated in Fig. 1. The control polymer electrolyte (without filler) showed lower compatibility with the lithium metal than CPE. The overpotential of the control electrolyte was higher than the overpotential of the CPE, indicating CPE has better compatibility with the lithium metal. The control electrolyte was stable up to 350 h, however, CPE was stable for more than 375 h (testing is still in progress). The Li dendrites growth was significantly reduced by CPE (Fig. 2) [1, 2].



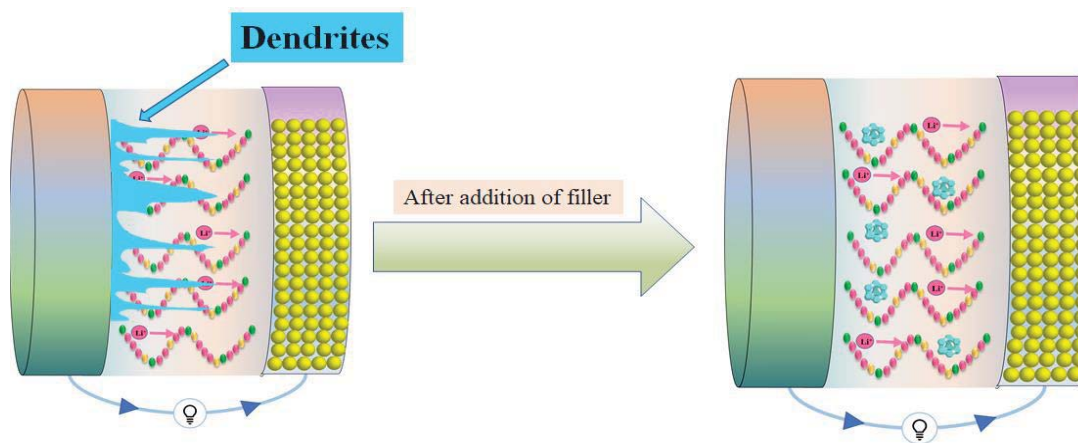




Renewables



**Fig. 1.** Galvanostatic lithium plating and stripping profiles for control (black color) and composite polymer solid-state electrolyte (blue color).



**Fig. 2.** Schematic for prevention of the lithium dendrites formation.

## Conclusions

A novel technique was adopted to synthesize a composite polymer-based solid-state electrolyte. This electrolyte improves the performance and stability of the all-solid-state lithium metal batteries at high temperatures (60 °C). This technology has great potential to be localized in harsh environmental conditions.

## References

- [1]. Jamal, H., Khan, F., Si, H.R. and Kim, J.H., 2021. Enhanced compatibility of a polymer-based electrolyte with Li-metal for stable and dendrite-free all-solid-state Li-metal batteries. *Journal of Materials Chemistry A*, 9(48), pp.27304-27319.
- [2]. Jamal, H., Khan, F., Hyun, S., Min, S.W. and Kim, J.H., 2021. Enhancement of the ionic conductivity of a composite polymer electrolyte via surface functionalization of SSZ-13 zeolite for all-solid-state Li-metal batteries. *Journal of Materials Chemistry A*, 9(7), pp.4126-4137.





## ***FORMULATE OF FAULT RIDE THROUGH (FRT) CRITERIA WITH LARGE-SCALE WIND INTEGRATION TO MAINTAIN SYSTEM STABILITY (SYSTEM OPERATOR PERSPECTIVE)***

Mohamed A. Hazzaa, Egyptian Electricity Holding Company, Ministry of Electricity and Renewable Energy, Cairo,  
Egypt,00201063348752,M.attia@moere.gov.eg

Sayed H. A. El-Banna, Electrical Engineering Department, Faculty of Engineering, Al-Azhar University, Cairo,  
Egypt,00201097715441,sayedelbanna@hotmail.com

Dalal H. M. Helmi, Egyptian Electricity Holding Company, Ministry of Electricity and Renewable Energy, Cairo,  
Egypt,00201222730828,dalal\_helmi@yahoo.com

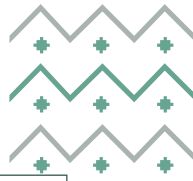
### **Overview**

Although high penetration of Renewable Energy resources (RESs) reduces negative impacts on environment, therefore reducing global warming compared to traditional fossil fuel-based power generation, control issues become more complicated where the system inertia is significantly decreased as result the absence of conventional synchronous generators[1].The appropriate control of the power electronic converters linked to the RESs is important to guarantee the power system stable operation during the transients, any disturbances, and AC system parameter variations. according grid code requirements, renewable energy sources have to stay connected during system faults and after clearing the faults. Thus, enhancement of fault ride through (FRT) capability of renewable energy conversion system becomes necessary. various methods have been presented in the literature to improve the FRT capability of wind energy systems connected to the grids. There are many challenges in the case of huge concentrated penetration of wind parks to high voltage transmission systems, which required developing stricter grid code requirements. One amongst these requirements is fault ride through (FRT), where has become the main dominant grid integration requirement for the wind energy system over world. Until last few years, wind parks generators have been designed to disconnect from the network in case of instantaneous voltage dips to protect the wind turbine plants until the grid restores its stability state[2, 3].With high integration of wind energy in closely interconnected networks, this response can drive to cascading collapse for the whole power system. the electric power system subjects to lots of operational and control challenges which obstruct its reliability and stability operation, as result of the integration of wind energy.The capability of FRT increases the stability of the grid and minimize generation shortage after the clearance of fault. Each network has its own grid codes depending on the state of each network. The aim of these rules is to enhance and stabilize wind turbine behavior, reduce the amounts of wind power to be lost following system disturbances and supply the wind power parks with operational characteristics analogue to those of the traditional power plants[4].To boost the fault ride-through (FRT) criteria of the doubly-fed induction generators (DFIGs) based wind turbines (WTs) during transient-state, an overview of various methodologies used have been presented in[5]. This paper displays studying the impact of the integration of large-scale wind parks and develop FRT requirements according to the characteristics of the power system under study for generators wishing to be integrated to this system.Coordination between wind farms and transmission lines protection schemes will be studied along with the co-influence of fault ride through capability on protective relay. Recommendations on the coordination between FRT and the under-voltage protection have been presented.

### **Methods**

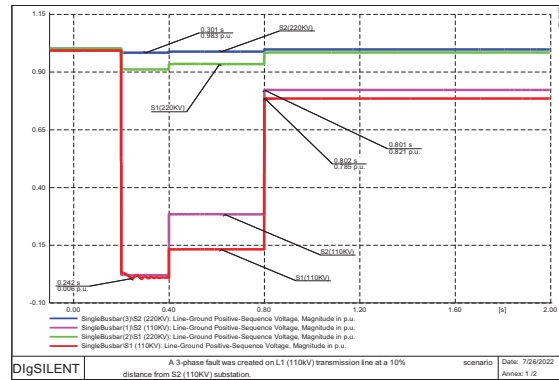
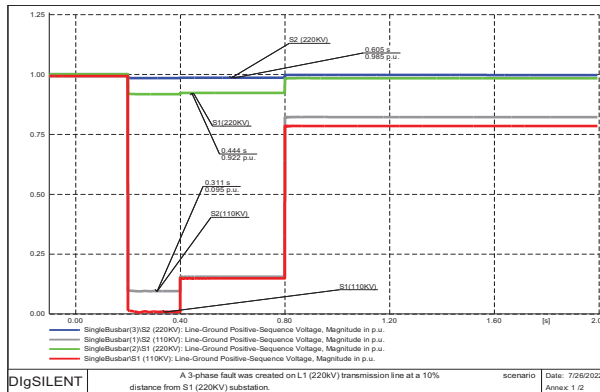
Understanding the characteristics of the transmission system is the first consideration to formulate a FRT criterion convenient with this system. In this case study,different scenarios of three-phase faults on the high voltage transmission network at various locations have been represented,Dynamic studies with special care on modeling Egypt Case have been done where this case study distinct that wind penetration is high in specific areas and at the same time no conventional generation exists in that place, and more, the wind parks connected with a long transmission line to the load Centre. Detailed aggregated modeling for wind parks having various generators technologies has been done along with studying different types of faults. Coordination between wind parks and transmission lines protection schemes will be studied along with the co-influence of fault ride through capability on protective relay using proper software (DIgSILENT® Power Factory) to realize the objective of this research.





## Results

The consequent fault current from each generator and voltage profiles of bus-bars under study at each scenario have been recorded. Finally, from figures showed below which show different voltage profiles could be integrated with each other to obtain the single final voltage duration profile compatible with the case under study. The main aim of this study is to formulate a fault ride-through (FRT) that is convenient with the characteristics of the system. Also the impacts on different protection schemes due to the integration of large-scale wind parks to power system have been presented.



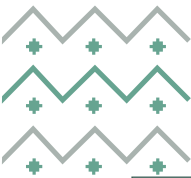
This curves are a part of the results

## Conclusions

Owing to the increasing integration of wind energy to the power system, reducing the outages of considerable large wind parks is very necessary to keep the reliability and the stability of the entire electrical power system as much as possible. Therefore, providing wind parks with a proper Fault Ride Through (FRT) appropriate to the characteristics of the system, their contingencies and protection system schemes is extremely important. This paper studied the influence of the integration of large wind parks and formulated FRT criteria for all generations wanting to be integrated to the high voltage transmission grid through dynamic study with special care on modeling Egypt Case. The Results of case studies that obtained have been used to analyze the voltage responses at different buses to get the final voltage profile appropriate to the characteristics of the network under study and its contingencies. Also, the paper proved that should be revision the grid code taking into consideration fully utilization of Fault Ride Through characteristics within DFIG and assuring full integration between this characteristics and protection settings so a revision should be done for the grid code.

## References

- [1] M. Shafiu Alam, F. S. Al-Ismail, A. Salem, and M. A. Abido, "High-level penetration of renewable energy sources into grid utility: Challenges and solutions," *IEEE Access*, vol. 8, pp. 190277–190299, 2020, doi: 10.1109/ACCESS.2020.3031481.
- [2] R. Piwko, N. Miller, J. Sanchez-Gasca, X. Yuan, R. Dai, and J. Lyons, "Integrating large wind farms into weak power grids with long transmission lines," *ieeexplore.ieee.org*, Accessed: Mar. 11, 2022. [Online]. Available: <https://ieeexplore.ieee.org/abstract/document/4778165/>
- [3] R. P. S. Leão *et al.*, "The implementation of the low voltage ride-through curve on the protection system of a wind power plant," *Renew. Energy Power Qual. J.*, vol. 1, no. 9, pp. 1312–1317, 2011, doi: 10.24084/repqj09.635.
- [4] M. Tsili and S. Papathanassiou, "A review of grid code technical requirements for wind farms," *IET Renew. Power Gener.*, vol. 3, no. 3, pp. 308–332, 2009, doi: 10.1049/IET-RPG.2008.0070/CITE/REFWORKS.
- [5] J. J. Justo, F. Mwasilu, and J. W. Jung, "Doubly-fed induction generator based wind turbines: A comprehensive review of fault ride-through strategies," *Renewable and Sustainable Energy Reviews*, vol. 45, 2015. doi: 10.1016/j.rser.2015.01.064.



## ***ENERGY TRANSITION AND REGULATORY ACTIONS***

[Amani Barnawi, King Abdulaziz University, 00966598050604, amanimustafa94@icloud.com]  
[Wejdan Asiri, The General Authority for Survey and Geospatial Information, 00966542498990, Asiriwejdan94@gmail.com]  
[Sarah Alsaadi, Naft AlSafi Co., 00966564446961, Alsaadi.sara1@icloud.com]

### **Overview**

Environmental concerns have led the world to reconsider the energy sector. Shifting to renewable energy sources has become a necessity giving the new international treaties, regional regulations and local policies. However, in terms of regulating, the current regulatory strategies covering the transition from traditional energy to renewable energy shows great limitations. Indeed, 2030 vision's initiatives of Saudi Arabia could be seen as a step towards an efficient energy regulation strategy. However, regulating this transition comes with various challenges, such as, the lack of integrated legislation, having few research facilities concerning energy regulation or a solid energy regulation theory. On the other hand, renewables has higher initial costs, smaller revenue stream, and inefficiency, in that sense, here comes another challenges relating to encouraging investments in renewable giving to the risks involved in To that end, this paper Firstly discussed the rationale behind regulation the sector, main theories in Energy Law. Secondly, it come across the vision of Saudi Arabia and its initiatives regarding the transition, and finally, analysing the gaps in energy regulation.

### **Methods**

The paper employs a doctrinal approach to analyse regulations regarding energy sector.

### **Results**

The paper has found that Regulation strategies concerning energy have to be evolving side by side to the international, national and local economic, environmental, financial, and social perspectives. Moreover, renewable energy impose various risks and challenges that need to be tackled. Finally, energy regulation regarding the transition shows great limitations in tackling the challenges.

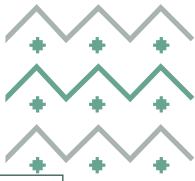
### **Conclusions**

While moving towards cleaner energy sector numerous and obvious regulatory challenges has to be considered. Current market structures, lack of understanding of the principles of new technologies based on renewable energy sources, difficult access to finance and its high cost, inadequate and the lack of a unified regulatory framework.

### **References**

- Al-Maamary, Hilal MS, H. A. Kazem, and M. T. Chaichan. "Changing the energy profile of the GCC States: A review." *International Journal of Applied Engineering Research (IJAER)* 11, no. 3 (2016): 1980-1988.
- Arent, Douglas J., Alison Wise, and Rachel Gelman. "The status and prospects of renewable energy for combating global warming." *Energy Economics* 33, no. 4 (2011): 584-593.
- Bridge, Gavin, Stefan Bouzarovski, Michael Bradshaw, and Nick Eyre. "Geographies of energy transition: Space, place and the low-carbon economy." *Energy policy* 53 (2013): 331-340.
- Byrnes, Liam, Colin Brown, John Foster, and Liam D. Wagner. "Australian renewable energy policy: Barriers and challenges." *Renewable Energy* 60 (2013): 711-721.





Edenhofer, Ottmar, Ramón Pichs-Madruga, Youba Sokona, Kristin Seyboth, Susanne Kadner, Timm Zwickel, Patrick Eickemeier et al., eds. *Renewable energy sources and climate change mitigation: Special report of the intergovernmental panel on climate change*. Cambridge University Press, 2011.

The Intergovernmental Panel on Climate Change:AR6 Synthesis Report: Climate Change 2022 <https://www.ipcc.ch/report/sixth-assessment-report-cycle/>.

Jinfang Tian,<sup>a</sup> Longguang Yu,<sup>a</sup> Rui Xue,<sup>b</sup> Shan Zhuang,<sup>d</sup> and Yuli Shan: Global low-carbon energy transition in the post-COVID-19 era.

Vision 2030 of KINGDOM OF SAUDI ARABIA <https://www.vision2030.gov.sa/thekingdom/explore/energy/>

Mhairi Garcia, Ziad Saad, Mohamad Alrifai: Renewable Energy Laws and Regulations Saudi Arabia 2023





## HYDROGEN PRODUCTION UTILISING CONCENTRATED SOLAR POWER (CSP) IN SAUDI ARABIA

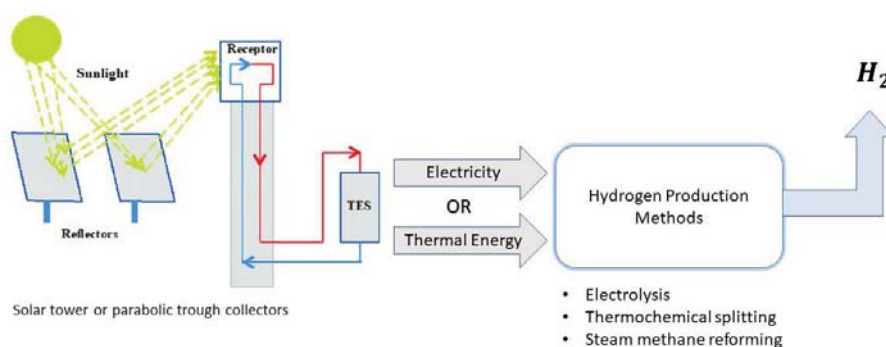
Alrwili Abdullah, Northern Border University, +996533415347, eng.abdullahayed@gmail.com

### Overview

Hydrogen energy can be a solution to the fossil fuel problems the world is facing. The aim of this study was to discover the optimum options for integrating concentrated solar power (CSP) with hydrogen production methods in NEOM city in Saudi Arabia.

### Methods

CSP projects of 100 MWe or equivalent thermal energy were simulated and integrated with three methods of hydrogen production on the System Advisor Model (SAM). These were electrolysis, thermochemical methods to produce green hydrogen and the steam methane reforming (SMR) process to produce blue hydrogen. Two kinds of CSP were simulated in this study: solar tower collectors (STC) and parabolic trough collectors (PTC).



### Results

[The results illustrated that the STC type worked more effectively than the PTC type in terms of generated energy and cost. Integrating CSP with electrolysis resulted in producing approximately 12751 tonnes per annum (tpa) of green hydrogen, whereas combining CSP with the thermochemical method was able to produce about 18260.5 tpa. Regarding the blue hydrogen, the third integration was able to provide 174602 tonnes of blue hydrogen per annum.

### Conclusions

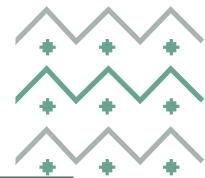
Several simulations were conducted and compared for each CSP type, STC and PTC, on SAM, leading to the observation that the STC type is more effective than PTC at a scale of 100 MW of electricity or equivalent thermal energy according to the annual energy generated and the cost, as revealed in the discussion section.

The effect of increasing the solar multiple without thermal storage was slightly negative for STC and positive in PTC. It was evident that TES played a significant role in increasing the generated energy and decreasing the levelised cost of PTC and especially STC in all eight conditions since it was able to raise the production capacity to about 40% for STC. Moreover, it reduced the cost by as much as 34% than without TES.

The CSP with a thermal method integration outperformed the combination of CSP with electrolysis in terms of the hydrogen quantity produced by more than 30%.

The best output of combining CSP with the thermochemical process was 18260.5 tpa of green hydrogen, and the cost of the thermochemical process was \$71.4 million. This was the same condition of integration as CSP with electrolysis.

Integrating CSP with SMR could create 174602 tpa of blue hydrogen, and the cost of the SMR process was \$103.02 million. The avoided amounts  $CH_4$  and  $CO_2$  were 108011.7 tpa and 297032 tpa, respectively.



## THE EFFECT OF GREEN HYDROGEN PRODUCTION GROWTH TO THE RENEWABLE ENERGY SECTOR

Muhammad Akimaya, King Fahd University of Petroleum and Minerals, +966 530432531,  
 E-mail: muhammad.akimaya@kfupm.edu.sa

### Overview

The energy transition becomes the goal of many countries ever since the Paris Agreement was signed back in 2016. It raised awareness and fueled significant research in renewable energy technology that ultimately results in a substantial reduction in the cost of generating electricity. It appeared as if we were getting closer to achieving sustainable energy and will soon be less reliant on fossil fuel as the main source of energy. However, the penetration of renewable energy in the electricity market seems to be constricted, especially in lesser developed countries. In fact, the utilization of fossil fuel to generate electricity is still growing (IEA 2022). Recently, hydrogen is under the spotlight as a solution to energy transition. Hydrogen combustion waste is water, which is harmless. It exists in gaseous form that can be stored easily while maintaining its energy content and thus, hydrogen appears to be the solution of the intermittent issue of renewable energy sources. Hence, there is a significant number of hydrogen production projects all around the globe (IEA 2021).

There are several different methods of producing hydrogen (IRENA 2019, IEA 2019). However, to be less reliant on fossil fuel, a green hydrogen method is what many countries are currently pursuing. It is called green hydrogen since it does not involve fossil fuels and there is no carbon waste in any of its processes. It uses power from renewable energy to perform water electrolysis to produce hydrogen. This would mean that a significant growth in hydrogen would have to come with a significant increase in renewable energy production. Hence, this research takes a closer look at the effect of hydrogen production growth to the renewable energy production structure. As electricity is one of the biggest part of the costs of producing green hydrogen, investors would always choose the most profitable path in its hydrogen production project. From an investment decision perspective, there is an option whether to use electricity from the grid or build an independent renewable energy power source. This research provides insights about the effect of the growth in hydrogen production quantity, as well as technology, on the investment decisions that would dictate the nature of renewable energy production. Would hydrogen economy growth drives decentralization of renewable energy?

### Methods

Structural models that represent the investment decision of the two options are developed. Since the price of green hydrogen differs significantly depending on the electrolysis technology and the location, the levelized cost of hydrogen (LCOH) is used as a proxy for profitability. Lower LCOH value implies higher profitability. The model for using the electricity from the grid is shown in Equation (1). Since the plant will be using the grid, the electricity cost will be exposed to market forces. Depending on the characteristics of the electricity market, the electrolysis process may be carried out during the peak period that has higher electricity tariff. The plant can be less reliant on electricity tariff by scaling up its facilities.

$$Total\ Cost = Capital\ Cost_{electrolysis} + Electricity\ Cost \quad (1)$$

Meanwhile, the independent power source model is shown in Equation (2). Since the plant has its own independent power source, it can perform electrolysis all year round. However, the cost of building the facilities of the power source would be included in the model. In addition, the capacity of the power source would dictate the hydrogen production capacity.

$$Total\ Cost = Capital\ Cost_{electrolysis} + Total\ Cost_{renewable} \quad (2)$$

The IEA data is used for the parameters on capital cost of electrolysis as well as capital cost for renewable energy (IEA 2019). The electricity tariff is based on average retail price of electricity (EIA 2022). The capacity factor and hydrogen conversion factor data are according to published research (IEA 2022, Element Energy 2018). The minimum cost of both options depending on the hydrogen output is simulated and compared to provide insights on investment opportunities. Furthermore, the growth of hydrogen production technology is simulated as well. Hydrogen production technological advancement can come into two different forms; a decrease in the capital cost and an increase in the conversion factor. Both cases are included in the analysis.

### Results

Based on the preliminary simulations results, the option to build an independent power source is never deemed attractive from an investment perspective. The cost of hydrogen production overall using an independent renewable source will always be significantly higher than relying on power from the grid at the current conditions, assuming that the power from the grid are coming from renewable energy sources. In the preliminary model, the







economies of scale is being ignored. However, given the significant gap of the total cost, the effect would be insufficient nevertheless.

The technological improvement in hydrogen production is also simulated. A substantial capital cost reduction of up to 50% as well as enhancement in hydrogen conversion factor of up to 100% are being considered. The LCOH significantly improved, however, it is insufficient to flip the attractiveness of the investment options. This is due to the fact that both options experience a cost reduction. The largest impact of reducing the gap between the two options actually comes from technological enhancement in renewable energy generation based on simulation results. For example, an increase in the renewable energy capacity factor or an even greater reduction in the capital cost. However, it never actually flip the attractiveness of the investment.

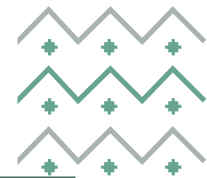
### **Conclusions**

The structural model provides an investment perspective on hydrogen production that is currently being pursued rigorously by many countries as part of energy transition goals. IEA (2019) predicts that hydrogen would grow significantly in the energy field, especially for green hydrogen. This research provides insights on the renewable energy sector conditions that have to support such growth. The technological improvement in the hydrogen production would definitely bring the production cost of hydrogen down, yet it has a negligible effect on decentralization of renewable energy generation. From an investment perspective, building an independent renewable energy source for green hydrogen production would be an unnecessarily higher cost that significantly impact its economic feasibility. This implies that the growth of hydrogen economy would bring heavier dependency on the electricity grid to deliver reliable power. The problem is that with more reliance on the grid and higher demand for renewable energy, it would inflict a larger cost to stabilize the grid. Since hydrogen is supposed to be the solution to the issue of intermittency of renewable energy, especially as an energy storage, it is actually a paradox. With higher fluctuation of electricity supply, more hydrogen would be required. However, it increases even further the amount of renewable energy generation required for the grid and ultimately causes greater instability to the grid.

### **References**

- EIA (2022). "Electricity Data". U.S. Energy Information Administration. <https://www.eia.gov/electricity/data.php>
- Element Energy (2018). Hydrogen Supply Chain Evidence Base. Element Energy Ltd.
- IEA (2019). The Future of Hydrogen: Seizing today's opportunities. International Energy Agency.
- IEA (2021). Global Hydrogen Review. International Energy Agency.
- IEA (2022). "Data and Statistics". International Energy Agency. <https://www.iea.org/data-and-statistics>
- IRENA. (2019). Hydrogen: A Renewable Energy Perspective. International Renewable Energy Agency.





[PAPER/POSTER TITLE]

## Energy Recovery and Cost Analysis for Conventional Vehicle and Hybrid Electric Vehicles

1. **Abdulrahman A. Alghamdi**, Faculty of Engineering, Mechanical Eng. Dept, Albaha University, KSA., [aass737656@hotmail.com](mailto:aass737656@hotmail.com)
2. **Eid S. Mohamed**, Faculty of Engineering, Mech. Eng. Dept, Albaha University, KSA. on leave from Dept. of Autom. Eng., Mataria, Helwan University, Cairo, Egypt, [e.mohamed@bu.edu.sa](mailto:e.mohamed@bu.edu.sa)

### Overview

In recent years, a significant interest in hybrid electric vehicle (HEV) has arisen globally due to the pressing environmental concerns and skyrocketing price of oil. Representing a revolutionary change in vehicle design philosophy, hybrid vehicles surfaced in many ways. The purchase price of a hybrid vehicle is higher compared to a conventional vehicle, both for passenger cars, buses, and trucks. However, given the lower fuel consumption, the total cost of life cycle cost of buying and using a hybrid can be equal to or even lower than buying and using a conventional vehicle depending on yearly mileage and fuel prices. The life cycle cost does not only include the cost of purchasing the vehicle but also the cost of fueling and maintenance. However, the maintenance will require more trained mechanics and possibly specialized maintenance centers in HEV.

### Methods

The research study is carried out by simulation the cost analysis of conventional vehicle and HEV. The life cycle cost in case study data of purchase price, maintenance, and fuel consumption are evaluated from popular cars in Saudi Arabia. The paper discusses costing trends of electric powertrain components and cost analysis for conventional vehicle and HEV. the cost analysis for conventional vehicle and HEV are estimated to evaluate payback period of cost of purchasing HEV.

### Results

The vehicle payback period is investigated for HEV and conventional vehicle, such as the operating costs and the purchase price of both HEV and conventional vehicle. In order to reach the time in which the price difference is recovered for the HEV. The payback period has from 4 to 5 years the cost of the purchasing HEV compare conventional vehicle for popular vehicles in Saudi Arabia.

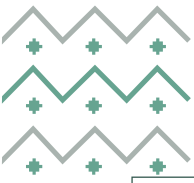
### Conclusions

The HEV cost-benefit equation is quite sensitive to a range of factors purchase price, maintenance, and fuel consumption in particular, However, the potential for HEVs to reduce per-vehicle fuel consumption is reduced in excess of 40% are available using HEVs in Saudi Arabia. The payback period has 4:5 years the cost of the purchasing HEV compare conventional vehicle.

### References

1. Tony M. Andrew S. "Cost-Benefit Analysis of Plug-In Hybrid Electric Vehicle Technology" The World Electric Vehicle Association Journal, Vol. 1, 2007, 294 -301.
2. Lipman, T.E. and M.A. Delucchi, A retail and lifecycle cost analysis of hybrid electric vehicles. Transportation Research Part D: Transport and Environment, 2006. 11(2): p. 115-132.
3. B. M. Al-Alawi and T. H. Bradley, "Total cost of ownership, payback, and consumer preference modeling of plug-in hybrid electric vehicles," Applied Energy, vol. 103, no. 2013, pp. 488–506, Nov. 2012.

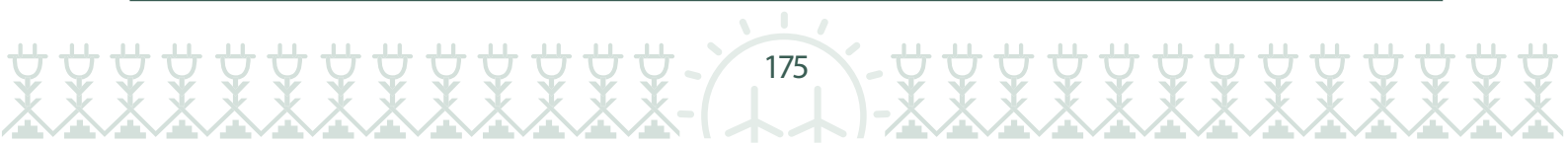


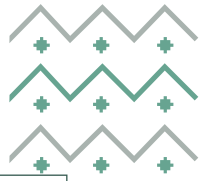


4. . Windisch, "The uptake of electric vehicles in the Paris region: a financial analysis of total costs of ownership," in European Transport Conference 2011, Glasgow, Scotland, UK, October 2011, 2011.
5. C.-S. Ernst, A. Hackbarth, R. Madlener, B. Lunz, D. Uwe Sauer, and L. Eckstein, "Battery sizing for serial plug-in hybrid electric vehicles: A model-based economic analysis for Germany," Energy Policy, vol. 39, no. 10, pp. 5871–5882, 2011.
- 6.



Renewables





## ***SUSTAINABLE ENERGY TRANSITION IN SAUDI ARABIA: MULTI-LEVEL PERSPECTIVE***

[Sarah Mohsen Alotaibi, King Faisal Center for Research and Islamic Studies, 0503233113, [Salaotaibi@kfcris.com](mailto:Salaotaibi@kfcris.com)]

### **Overview**

In recent years, the energy sector of Saudi Arabia observed several transformations and reforms. This continuing transition resulted in a shift in various sectors at the local level. In other words, different interactions between actors and institutions within the energy system are compared with the previous energy system. It has been shown that understanding the energy transition, as they move from one energy mix structure to another not only depends on such national policies that are led by governments but also other various aspects, dimensions, and complex interplay in different levels of energy industry besides the barriers that involve legal, infrastructure, financial factors, competing interests and agendas between the actors, etc.

This research goes on the role of these actors who intervene in the energy transition progression through diverse stages. Saudi Arabia has the most fossil fuel-intensive electricity and demand per capita rises at a pace according to a report published by "Ember's Global Electricity Review". The renewable energy contributions in the total energy mix compared with the electricity generation from gas and oil are very low. According to BP's Statistical Review of World Energy 2021, there is only 0.3% of its electricity supply came from renewable energy in 2020. Nevertheless, the current consequences do not necessarily reflect the reality when we look at developments at different levels happening in recent years.

These improvements can be divided into different levels and dimensions to identify the role of the main actors in the energy transition progress to evaluate and improve understanding of transition. This abstract attempts to using the Multi-level perspective framework to see eventually what actions and actors are the real driver's elements to facilitate the energy transition process?. The importance of the research is that no previous research has investigated energy transition whether in Saudi Arabia or GCC countries by using this framework. Therefore, this study aims to provide a starting point for understanding energy transition at the local level by describing the current interaction between actors and identifying the enablers, and barriers to, low-carbon energy transitions within the local power system. It is important to indicate that given the fact of how depth and complication explain transition at these three levels, the study tries to shed light on the main topics and developments in kind and rates of renewable energy transition deployment in Saudi Arabia.

In 2017, Saudi Arabia has proposed National Renewable Energy Program, planning to address the increasing demand for using renewable resources. On contrast, Public Investment Fund (PIF) is leading the development of 70% of the renewable energy target through direct negotiations with investors to develop Giga-scale projects. However, the Renewable Energy development project office (REPDO) would auction the remaining 30% of Utilities. It oversees the procurement of 30% of this target via a competitive process. In this context, there are growth in renewable energy projects with launched five new projects to produce electricity using renewable energy under the NREP, REPDO moving ahead with plans for the fourth and fifth phases of its ambitious renewable energy programming, with a total capacity of 3,300 megawatts in 2021. In the last round, the government finalized power purchase agreements (PPAs) for seven solar power projects with an average price of about \$18.3/MWh. On the other hand, sustainable hydrogen usage and reduced emissions by 278 mt by 2030 through the Circular Carbon Economy (CCE) approach, put Saudi Arabia in a great position to preserve driving transformation and raise prospects for sustainable growth. Additionally, the steps that have been taken in the national strategies resulted in significant accomplishments. For instance, Saudi Arabia has received attention for its announcements of the shipment of Blue Ammonia to Japan; the world's first shipment of environmentally-friendly high-grade blue ammonia.

### **Methods**

Sustainable energy transition theories such as the Multi-Level Perspective (MLP). For instance, it has been developed to analyze and understand the change processes in a complex system. The framework has been used to evaluate transitions through interaction processes within three analytical levels: niches, socio-technical regimes, and a socio-technical landscape. These three levels represent a structural hierarchy of an industry (Geels, 2002). The landscape level is defined as an exogenous environment that involves, macro-economic, political developments, deep cultural patterns, international governance, international geopolitical economics, and social sitting. Regarding the socio-technical regime, this level is



described as the Meso-level which is formed by engineering practices and routines alongside dominant technologies linked together. According to (Geels et al., 2017), "this level involves Social practices, scientists, policymakers and other interdependent groups that help to shape the regime level". However, the socio-technical regime in general is not eager to change and possesses certain resistance. For the Niches level, it is considered as the micro-level with special conditions for the rise of radical innovations. Also, it is understood as the level governed by the dominant from the socio-technical regime and socio-technical landscape. Regarding the explanatory nature of the study, the research follows the thematic analysis, to identify the actors and enablers, of the energy transition. Data collection was conducted in two steps. The first was focused on gathering data from, documents including government reports, national strategies, policy documents, and industrial and academic publications. The second was from interviews with relevant actors and stakeholders at the national level.

## Results

After giving a general outline of the developments in the energy sector. The results of the analysis are presented and discussed in more detail structured according to the three levels of the MLP.

The first is the landscape level, The progress of renewable energy projects at the local level is attributable, among others, to the shift in the government's policy that set ambitious targets to meet Net Zero carbon emissions by 2060, In addition, to producing 50% of electricity from renewable energy sources by 2030. Moreover, the regional green initiatives, the Middle East Green Initiative Summit and Saudi Green Initiative Forum (SGI) announced during the Global Climate Change Conference (COP27) in the second edition can display extraordinary changes at the landscape level, which therefore exert pressure for change on the regime, and still characterized by centralized power generation based largely on both gas and fossil fuels. However, all these showing concrete commitments to implementing the strategy and bringing more developments in long term.

Second is the socio-technical regime, which involves institutions, socioeconomic and legal structures, and (incumbent) actor constellations. The socio-political system in Saudi Arabia is dominance of oil and gas culture in the power system and energy system in general weaker environmental tradition. Moreover, system is rentier-based structure that advocates high energy subsidies and living regulations, leading to inefficient energy consumption. However, the major change can be seen when Saudi Arabia's Cabinet formed a Supreme Committee for Energy Mix Affairs for Electricity Production to enable Renewable Energy Sector. As a response to the challenges, in 2020 during the pandemic, there were sharp downturns in economic activity have resulted in significant losses in electricity revenues because of the high subsidies for electricity, which have resulted in more reforms in the electricity sector. On the other hand, when it comes to self-consumption, the largest percentage of electricity consumption comes from the residential sector. Thus, there are many explanations for the slow growth of renewable energy percentage. For instance, Policy in promoting renewables mostly chooses Large-scale Options. While the Small-scale options face the obstacle that remains in the legal framework. However, It's worth mentioning that, on February 28, 2020, Water and Electricity Regulatory Authority (WERA) issued the updated regulatory framework "Saudi Regulation for Small-Scale Solar" for distribution systems connected to the utility grid. (New framework uses Net Billing instead of a Net-metering Scheme. In this regard, the legal framework is the main barrier and concern. The main reason is that capacity for each facility ranges from 1 KW to 2 MW. Moreover, the capacity at the country-wide defined maximum cap can be calculated today as 1.8 GW on a national level.

The third is the niche level, the environment in which radical innovations can emerge and grow, and which initially is outside public awareness (Geels,2007). This is where technical innovations and new business models are developed. Though, the new trends on the landscape level that intention to move forward to the low-carbon system have enabled new actors. For example, new global projects such as NEOM stimulate the use of advanced renewable energy technology. In this, Saudi Arabia's objective is to host the world's largest green hydrogen plant to contribute to attracting more companies. Baker Hughes in collaboration with ACWA power, for example, announced it will provide Air Products with advanced hydrogen compression and gas turbine technology for global projects, including, the NEOM carbon-free hydrogen project in the Kingdom of Saudi Arabia. Furthermore, Saudi companies have received the world's first independent certifications recognizing blue hydrogen and ammonia production such as Aramco, SABIC, and Ma'aden.

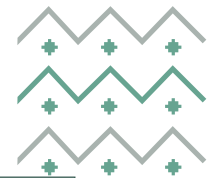
## Conclusions

This research analyzes Saudi Arabia's energy transition toward a low-carbon energy system based on the multi-level perspective approach. These findings support the notion that local actors, political will, and regulatory framework could show a crucial role in future sustainable energy systems. The main finding is that there are developments on all three levels from the MLP perspective. On the other side, Generating electricity from renewables in the regime is still restricted. One of the reasons is that the regime has a relatively strong influence on the niche through the regulatory framework and there is a requirement for enabling instruments that permit new actors to perform a role such as self-consumers and producers. Thus, this can open a window of opportunity when self-consumers gain market share, ultimately will contribute to further enabling Saudi Arabia's export infrastructure for clean fuels.



Renewables





## Energy Consumption, Urbanisation, Economic growth and Carbon dioxide Emissions: Evidence from Middle East and North Africa.

Geoffrey Ssebabi Mutumba <sup>1\*</sup>, Economics, Faculty of Science, Kyambogo University +256752566591 [gmutumba@kyu.ac.ug](mailto:gmutumba@kyu.ac.ug)  
 Jacob Otim, Economics, Faculty of Science, Kyambogo [jotim@kyu.ac.ug](mailto:jotim@kyu.ac.ug)

### Abstract

**Back ground:** This study examines the causal relationship between energy consumption, Urbanisation, economic growth and carbon dioxide emissions from Middle East and North Africa (MENA). Whereas energy consumption, urbanization and economic growth are critical drivers of carbon dioxide emissions, studies have conflicting results on the direction of causality.

**Methods:** The study will use Fully modified Ordinary Least Squares (FMOLS) and Dynamic ordinary least squares(DOLS within a multivariate data framework. Panel cointegration and panel causality tests are used to establish to energy, urbanization, growth and carbon dioxide nexus.

**Results:** The results support the conservation hypothesis between energy consumption. There is a positive relationship between economic growth and energy consumption while a negative relationship exists between economic growth and carbon dioxide emissions.

**Conclusion:** The conclusion therefore is that these economies can be able to increase energy consumption without adverse effects on environmental quality.

#### Implications/Relevance/Originality /Value

This study will provide a better theoretical understanding using a multivariate framework on the energy consumption, urbanization, economic growth and CO2 nexus. This will empower Economic planners on developing and implementing evidence based policies.

Key Words: Energy Consumption, Urbanisation, Industrialisation, Economic growth, Carbon dioxide, MENA

### Overview

#### 1.1 Preamble

Energy consumption, urbanization, economic growth and carbon dioxide (CO<sub>2</sub>) emissions constitute a debate of ongoing concern in the world today (Banday and Aneja, 2018). The global increase in the consumption of energy and urbanization has been condemned for leading to increasing terrestrial carbon dioxide (Khairullina et al., 2019). The indiscriminate human activities in setting up urban centres and use of energy resources in pursuit of economic growth has sparked off an imbalance in the biodiversity and ecological systems. This has resulted in increased greenhouse gases like CO<sub>2</sub> (Otim et al., 2022). The increasing levels of carbon dioxide is believed to be the leading cause of global warming and climatic change (Rehman et al., 2021).

The overarching debate is that increase in energy consumption, urbanization promotes CO<sub>2</sub> emissions up to the peak as per the Environmental Kuznets curve (EKC) (Saboori, 2012, Banday, 2014, Banday and Ismail, 2017)). Other researchers, however, found little evidence to uphold this relationship (Gorus and Aydin 2018). Controversy still exists on the direction of causal relationship between energy consumption, urbanization, economic growth and CO<sub>2</sub> emissions (Mutumba et al., 2021a). This debate is not yet concluded even among climate change scientists (Oreskes 2018). Yet other critics have dismissed these scientists as having nothing to tell the world about reality (Maki 2012). Energy economics is one of those areas with appropriate tools and evidence to facilitate this debate to a logical conclusion (Omri, 2013).

#### 1.2 Motivation

Following the controversial debate, this study seeks to investigate the dynamic causal relationship between energy consumption, Urbanisation and industrialisation, economic growth and CO<sub>2</sub> emissions (Ummalla and Samal 2019). It will further interrogate the dynamic causal relationship between urbanization, economic growth and CO<sub>2</sub> emissions nexus. This will give a precipice to policy makers with some evidence based decision making. The growing concern over this controversial debate will be handled to an innovative and problem solving approaches that it warrants.

#### 1.3 Hypothesis

The main arguments for this study that have been a rock bed of controversy are in four major parts namely the conservation, growth, feedback and neutrality hypothesis (Mutumba et al., 2021).

- (i) The conservation hypothesis takes on the argument that there exists a unidirectional relationship running from economic growth and energy consumption (Rahman & Velayutham 2020). It means this is valid for a nation that is not energy dependent, and reducing energy consumption does not necessary affect growth of the overall economy.
- (ii) The growth hypothesis takes on the argument that there exists a unidirectional relationship running from energy consumption and economic growth Kirikkaleli Adedoyin & Bekun 2021). This is effective for a nation that is energy dependent as increasing energy consumption will have a multiplier effect on economic growth.







- (iii) Feedback hypothesis advances an argument of two-way causal relationship between energy consumption and economic growth (Jin et al., 2022). This is evidenced in the reversed causality between short and long run causality between the two variables of study.
- (iv) Neutrality hypothesis argues that there is no significant causal relationship between the variables of study (Raggad 2021). It is set on the premise that energy consumption has a minute relationship with growth.

#### 1.4 Value added

Energy consumption makes a handsome contribution to employment and GDP (Khan and Hou, 2021). Urbanisation is another instrumental building brick of the economy. However, these two have been condemned for the growing rise of CO<sub>2</sub> emission which threaten the overall sustainable growth and development agenda. As per the Sustainable development goals (SDG) 7 that advocates for reliable and affordable modern energy for all, while SDG 13 that advocates for sustainable urban communities and cities for all for promoting economic growth and sustainable development in the long term.

This study will provide a better theoretical understanding using a multivariate framework on the energy consumption, urbanization, economic growth and CO<sub>2</sub> nexus. This will empower Economic planners on developing and implementing evidence based policies.

#### 1.5 Roadmap

The remainder of this paper is section two, methods, in section three findings and discussion and finally conclusions and policy recommendations.

### Methods

#### 2.1 Data source

Annual data has been taken from World Bank Development Indicators (WDI, 2020) for GDP, Energy consumption, Gross Domestic Product (GDP), Urbanisation (URB), Industrialisation (Ind), and CO<sub>2</sub> emissions. Time series data for all the 15 MENA including Algeria, Cyprus, Egypt, Iran, Israel, Jordan, Kuwait, Morocco, Oman, Saudi Arabia, Sudan, Syria, Tunisia, Turkey and United Arab Emirates 1970-2019 giving 50 data points, the data set is large enough to increase size and explanatory power of unit roots and panel co-integration techniques.

#### 2.2 The Theoretical Model- Environmental Kuznet

The earliest of works on the Environmental Kuznets Curve (EKC) can be traced from Simon Kuznets (1955) himself, whose foundational work on the Kuznets curve raised vital tentative arguments on the relationship between income per person and income inequality (Bashir et al., 2021). Kuznets (1955) contends that the income gap tends to increase during initial stages of growth and to decline as these incomes grow. In describing an inverted-U shaped relationship between per capita income and disparities in income. In the 1990s, the study was rekindled by Grossman and Krueger (1991), the Kuznets curve was rekindled as an analytical tool to explain the relationship between the levels of environmental quality now operationalized as Carbon dioxide emissions in this paper and per capita income. The term EKC was conjecture by Panayotou (1993) for its closeness to Kuznets' hypothesis (Dogru et al., 2020).

According to EKC, after GDP increases up to a certain point, it will ameliorate the environmental effect of the initial stages of economic development and will offset the relationship between Gross Domestic Product (GDP) per capita and pollutant emissions per capita is in the shape of an inverted-U. For our posterity, therefore we demonstrate that economic growth benefits environmental quality beyond which this tradeoff is lost (Niu and Li, 2014).

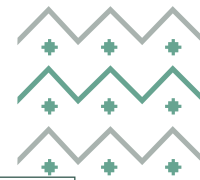
EKC is attributed to the production scale, structure and abatement; Production scale input rates explains production increasing with production range and level of technology. Industries have varying levels of pollution intensity while production range varies in the process of economic development. Varying output to replace harmful inputs by less environmentally harmful ones or the reverse. Emission changes in input per unit may result with less pollution due to developments in technology.

The EKC hypothesis postulates that a rise in stock pollutants will develop a country's industry and this will gradually decline after an economic development threshold level is attained. Therefore, environmental damage is the trade off at the first stage of economic development and for this reason countries will not overcome it unless the reversing effect is overcome.

The level of CO<sub>2</sub> emissions in an area is correlated with CO<sub>2</sub> levels throughout the wider region. The natural determinants are secondary with minimal and self-correcting effects on environmental quality. CO<sub>2</sub> emission levels on aggregate output is influenced by CO<sub>2</sub> emission-generating works and cleaning activities. Actual pollution levels and thus the CO<sub>2</sub> intensity of aggregate output emerge as a result of these two opposite effects. While the rate of Pollution generating activities depends on declining input on these variables, the CO<sub>2</sub> emissions depend on aggregate output composition. Therefore, these are Composition or Structure Effect (C) and Abatement Effect (A). It is obvious that Output per unit area represents Scale Effect (L) (Islam, Vincent and Panayotou; 1999). The effects of various correlates, such as, technology transfer, international trade, Domestic and foreign investment, policy and institutional variables feed into the above three effects. Along with the economic growth, the scale of an economy tends to become larger and larger, global inputs will steadily rise (Grossman 1995).

#### 2.3 The Econometric Model: Fully modified Ordinary least squares (FMOLS).





### 2.3.1 Variable Description

Variables of study have been carefully selected as explained in the table, to avoid misspecification a Ramsey RESET (Regression Specification error test) was done. The variables selected their measurement and expected signs have been shown in table 1.

Table 1: Variable description and expected signs

Variables	Symb ol	Measure	Expected Sign	Data source
Gross Domestic Product	GDP <sub>t</sub>	GDP constant 2010 US\$	+	World Bank: World development indicators(WDI)
Urbanisation	Urb <sub>t</sub>	% population in Urban area	+	World Bank: World development indicators (WDI)
Carbon dioxide	CO <sub>2t</sub>	Kilotons	+	World Bank: World development indicators(WDI)
Energy consumption	E <sub>t</sub>	kWh	+	International Energy Agency (IEA)
Industrialisation	Ind	% Industrial Output	+	World Bank: World development indicators(WDI)

### 2.3.2 The panel fully modified ordinary least squares model

The ex post- facto research design was adopted to allow for the use of time series data Chinedu et al. (2019). Due to cross sectional dependence (CD) employed a fully modified ordinary least squares model by Phillips and Hansen (1990) was undertaken. This model uses semi parametric correction to remove the problems caused by CD between the cointegrating equation and random regressors. The benefit of FMOLS estimator is that it is unbiased and asymptotically efficient. Cross sectional dependence was a deep-seated problem in our data arising from two main issues namely; spill overs and unobservable factors between regions. These factors include technology and technological transfers, Capital inflows and international trade amongst members implying that CD can no longer measure up to solve the key matters of this study. Therefore the modelling has to be done taking care of this. This withstanding a Hausmann CD test was done to determine whether a fixed or random effects model was more appropriate. The fixed model is operated when there exists time invariant variables for time variant effects and the specific effects is a random variable allowed to be correlated with the explanatory variable Salim et al., (2014). The random effects model was more appropriate.

## 2.4 Diagnostic tests

This subsection mainly looks at post estimation tests particularly the test from stationarity and unit root, serial correlation, functional form, co-integration, heteroscedasticity and normality as explained.

### 2.4.1 Test for Stationarity and Unit Root

To test for unit roots in our variables, we use the Panel Augmented Dickey Fuller (PADF), Levin Lin and Chu (2003), Im Pesaran and Shin W- statistic, ADF Fisher and PP-fisher chi square test. Using the results of Dickey and Fuller (1979), the null hypothesis that the variable shows that all variables have unit roots. Electricity consumption (E) is stationary at first difference.

### 2.4.2 Determining the appropriate Lag Length for FMOLS

The need for the lags arises because values in the past affect today's values for a given variable. This is to say the variable in question is persistent. There are various methods to determine how many lags to use. The AIC was used to determine the appropriate lag length given the large sample size of 31 observations. The appropriate lag length is 2.

### 2.4.3 Panel Co-integration test

This test is used to check if there exists a long-run relationship between the study variables. Generally, a set of variables is said to be co-integrated if a linear combination of the individual series, which are I(d), is stationary. Intuitively, if  $x_t \sim I(d)$  and  $y_t \sim I(d)$ , a regression is run, If the residuals,  $\epsilon_t$ , are I(0), then  $E_t$  and  $y_t$  are co-integrated. We use Johansen's (1988) approach, which allows us to estimate and test for the presence of multiple co-integration relationships. The choice of lag length is made according to the AIC criterion. In conclusion there is one co-integration rank (long-run relationship). When determining lag structures of the data-generating processes (DGP), we use the Johansen (1988) procedure to test the existence of long-run equilibrium relations using the trace statistic test for co-integration, because our data are based on rather small samples, the estimation procedure that we adopt accounts for the Bartlett correction following Johansen (2000). The Johansen co-integration procedure does not reject the null hypothesis of one co-integrating equation. The Johansen trace and max test statistics suggest the existence of at least 1 co-integrating relationship between GDP and electricity consumption. According to Henry and Mizon (1978), this choice of the econometric model is because of existence of a co-integration problem. Since the error structure in nonstationary in levels, the problem is estimated in a first difference formulation. The Dickey Fuller test is used to determine whether the remainder is stationary Dickey Fuller, and the Augmented Dickey Fuller test is applied on the least square residual to implement the Engel and Granger procedure.





2.4.4 Test for functional form

We may have a model that is correctly specified, in terms of including the appropriate explanatory variables, yet commit functional form misspecification. In this case, the model does not properly account for the form of the relationship between dependent and observed explanatory variables. In this study, a general test for functional form misspecification is Ramsey's RESET (regression specification error test) which was applied.

2.4.5 Test for heteroscedasticity

The error term is found to homoscedastic using the Breush Pagan test this shows the stability of the parameters using residual diagnostics to minimize errors (or residuals). The error term is be independently and identically distributed (i.i.d). Using the correlogram, the error term of the estimated model. This procedure of log transformation is important because it stabilises the means, however the means are also found to be non-stationary.

2.4.6 Test for normality

The Jacque Bera normality test was used to test for normality, which variable is relevant to express as linear combination among other variables, using the Maximum Likelihood- Auto Regressive Conditional Heteroscedasticity (ML ARCH) the residuals were normally distributed.

2.4.7 Causality test

A panel based on Error correction model (ECM) was applied and later a Engle and Granger (1987) causality is applied for both short and long run dynamics.

$$Y_{it} = \mu + \sum_{j=1}^n \gamma Y_{t-j} + \sum_{j=1}^n \alpha_1 E_{t-j} + \sum_{j=1}^n \alpha_2 Urb + \sum_{j=1}^n \alpha_3 GDP_{t-j} + \sum_{j=1}^n \alpha_4 Ind_{t-j} + \sum_{j=1}^n \alpha_5 CO2 + \partial it \text{ ECT}$$

$$u_t \dots \dots \dots (9)$$

$$H_0 : \gamma = 0 \text{ for } j = 1, \dots, n$$

$$H_1 : \alpha \neq 0 \text{ for at least one } j \dots \dots \dots (10)$$

Where  $\mu$  is a constant and  $u_t$  is a white noise process,  
 E -Energy Consumption, Urb -Urbanisation,  
 GDP Economic growth Ind- Industrialisation,  
 CO2 = carbon dioxide ECT is the Error correction mechanism.  
 The optimal lag length is determined by the Schwartz Information criteria (SIC)

3.0 Results and Discussion

The results support the conservation hypothesis between energy consumption. There is a positive relationship between economic growth and energy consumption while a negative relationship exists between economic growth and carbon dioxide emissions.

4.0 Conclusion and Policy recommendations

The conclusion therefore is that these economies can be able to increase energy consumption without adverse effects on environmental quality.

References

Adebola, S.S. (2011). Electricity Consumption and Economic Growth: Trivariate investigation in Botswana with Capital Formation. *International Journal of Energy Economics and Policy*. 1(2) 32-46 ISSN: 2146-4553.

Al-mulali, U., Lee, J. Y., Mohammed, A. H., & Sheau-Ting, L. (2013). Examining the link between energy consumption, carbon dioxide emission, and economic growth in Latin America and the Caribbean. *Renewable and Sustainable Energy Reviews*, 26, 42-48.

Andjarwati, T., Panji, N.A., Utomo, A.Susila, L.N. Respati, P.A. and Bon, A.T. (2020). Impact of energy consumption and economic dynamics on Environmental degradation on ASEAN *International Journal of Energy Economics and Policy* 10(5) 672-678 ISSN: 2146-4553

Asif, M. Sharma, R.B. & Adow, A.H.E (2015). An Empirical Investigation of the Relationship between Economic Growth, Urbanization, Energy Consumption, and CO2 Emission in GCC Countries: A Panel Data Analysis *Asian Social Science* 11 (21) ISSN 1911-2017 E-ISSN 1911-2025 Canadian Center of Science and Education.

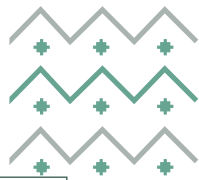
Bakirtas, T., and Akpolat, A.G. (2018). The Relationship between Energy Consumption, Urbanization, and Economic Growth in New Emerging-Market Countries, *Energy* doi:10.1016/j.energy.2018.01.011.

Banday, U.J. & Ismail, S. (2017). Does tourism development lead positive or negative impact on economic growth and environment in BRICS countries? A panel data analysis. *Economics Bulletin* 37 (1) 553-567.

Banday, U.J., Assawa, A. & Kaushik, G. (2014). Tourism and its impact on economic growth and environment. *Asian Economic Review*. 56 (3). 147-162.

Banday,U.J. & Aneja,R., (2018). Energy consumption, economic growth and CO2 emissions: evidence from G7countries. *World Journal of Science, Technology and Sustainable Development*, <https://doi.org/10.1108/WJSTSD-01-2018-0007> <https://doi.org/10.1108/WJSTSD-01-2018-0007>.

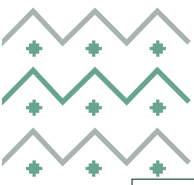




- Bao, C., & Xu, M. (2019). Cause and effect of renewable energy consumption on urbanization and economic growth in China's provinces and regions *Journal of Cleaner Production* 231 483-493.
- Bashir, M. F., Ma, B., Bashir, M. A., & Shahzad, L. (2021). Scientific data-driven evaluation of academic publications on environmental Kuznets curve. *Environmental Science and Pollution Research*, 28(14), 16982-16999.
- Charfeddine, L., & Mrabet, Z. (2017). The impact of economic development and social-political factors on ecological footprint: A panel data analysis for 15 MENA countries. *Renewable and sustainable energy reviews*, 76, 138-154.
- Destek, M.A. & Ozsoy, F.N. (2015). Relationships between economic growth, energy consumption, globalization, urbanization and environmental degradation in Turkey. *International Journal of Energy and Statistics Institute for International Energy Studies* 3 (4) 1550017 1-13. DOI: 10.1142/S2335680415500179.
- Temiz Dinç, D., & Akdoğan, E. C. (2019). Renewable energy production, energy consumption and sustainable economic growth in Turkey: A VECM approach. *Sustainability*, 11(5), 1273.
- Dogru, T., Bulut, U., Kocak, E., Isik, C., Suess, C., & Sirakaya-Turk, E. (2020). The nexus between tourism, economic growth, renewable energy consumption, and carbon dioxide emissions: contemporary evidence from OECD countries. *Environmental Science and Pollution Research*, 27(32), 40930-40948.
- Elfaki, K. E., Poernomo, A., Anwar, N., & Ahmad, A. A. (2018). Energy consumption and economic growth: empirical evidence for Sudan. *International Journal of Energy Economics and Policy*, 8(5), 35.
- Ghosh, B. C., Alam, K. J., & Osmani, M. A. G. (2014). Economic growth, CO2 emissions and energy consumption: The case of Bangladesh. *International Journal of Business and Economics Research*, 3(6), 220-227.
- Gorus, M.S. & Aydin, M. (2018). The Relationship between Energy Consumption, Economic Growth, and CO2 Emission in MENA Countries: Causality Analysis in the Frequency Domain, *Energy*, doi: 10.1016/j.energy.2018.11.139.
- Jin, L., Chang, Y. H., Wang, M., Zheng, X. Z., Yang, J. X., & Gu, J. (2022). The dynamics of CO2 emissions, energy consumption, and economic development: evidence from the top 28 greenhouse gas emitters. *Environmental Science and Pollution Research*, 29(24), 36565- 36574.
- Karanfil, F., & Li, Y. (2015). Electricity consumption and economic growth: Exploring panel-specific differences. *Energy policy*, 82, 264-277.
- Khairullina, E. R., Bogdanova, V. I., Slepneva, E. V., Nizamutdinova, G. F., Fatkhullina, L. R., Kovalenko, Y. A., & Skutelnik, O. A. (2019). Global climate change: Cyclical nature of natural and permanent nature of man-made processes. *EurAsian Journal of BioSciences*, 13(2), 2311-2316.
- Khan, M.K., Teng, J., Khan, M.I., (2019). Energy consumption and economic growth on carbon emissions in Pakistan with dynamic ARDL simulations approach *Environmental science & Pollution Research*. <https://doi.org/10.107/s.11356.019.05640-x>
- Khan, M.K., & Younas, M.L. (2019). Interaction between Energy consumption and economic growth on carbon emissions in Pakistan: A more comprehensive Analysis using ARDL approach *Energy Economic Letters*. ISSN (e): 2308-2925
- Khan, I., & Hou, F. (2021). The dynamic links among energy consumption, tourism growth, and the ecological footprint: the role of environmental quality in 38 IEA countries. *Environmental Science and Pollution Research*, 28(5), 5049-5062
- Kirikaleli, D., Adedoyin, F. F., & Bekun, F. V. (2021). Nuclear energy consumption and economic growth in the UK: evidence from wavelet coherence approach. *Journal of Public Affairs*, 21(1), e2130.
- Khobai, H. B., & Le Roux, P. (2017). The relationship between energy consumption, economic growth and carbon dioxide emission: The case of South Africa. *International Journal of Energy Economics and Policy*, 7(3), 102-109.
- Khobai, H. (2018). Electricity consumption and economic growth: A panel data approach for Brazil, Russia, India, China and South Africa countries. *International Journal of Energy Economics and Policy*, 8(3), 283.
- Komal, R. & Abbas, F. (2015). Linking financial development, economic growth and energy consumption in Pakistan. *Renewable and Sustainable Energy Reviews* 44 211–220.
- Kwakwa, P. A., & Aboagye, S. (2014). Energy consumption in Ghana and the story of economic growth, industrialization, trade openness and urbanization. *Asian Bulletin of Energy Economics and Technology*, 1(1), 1-5.
- Liu, Y. (2009). Exploring the relationship between urbanization and energy consumption in China using ARDL (autoregressive distributed lag) and FDM (factor decomposition model). *Energy*, 34(11), 1846-1854.
- Maki, U (2012). Handbook of the Philosophy of Science Vol.13 Philosophy of Economics. Elsevier.
- Mohammadi, H., & Parvaresh, S. (2014). Energy consumption and output: Evidence from a panel of 14 oil-exporting countries. *Energy Economics*, 41, 41-46.

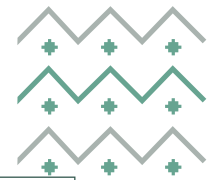






- Mutumba, G.S., Odongo, T., Okurut, N.F., & Bagire, V. (2021). A survey of literature on energy consumption and economic growth *Energy Reports* 7 9150-9239.
- Mutumba, G.S., Odongo, T., Okurut, F.N ·Bagire, V. & Senyonga, L. (2022). Renewable and non-renewable energy consumption and economic growth in Uganda. *SN Bus Econ* 2:63  
<https://doi.org/10.1007/s43546-022-00220-7>.
- Niu, H., & Li, H, (2014). An Empirical Study on Economic Growth and Carbon Emissions of G20 Group. International Conference on Education Reform and Modern Management, 2014.[http://www.atlantispres.com/php/download\\_paper.php?id=11293](http://www.atlantispres.com/php/download_paper.php?id=11293), (07.03.2014).
- Omri, A. (2013). CO2 emissions, energy consumption and economic growth nexus in MENA countries: Evidence from simultaneous equations models. *Energy economics*, 40, 657-664.
- Oreskes, N. (2018). The scientific consensus on climate change: How do we know we're not wrong?. In *Climate modelling* (pp. 31-64). Palgrave Macmillan, Cham.
- Otim, J., Mutumba, G., Watundu, S., Mubiinzi, G., Kaddu, M (2022). The Effects of Gross Domestic Product and Energy Consumption on Carbon Dioxide Emission in Uganda (1986-2018). *International Journal of Energy Economics and Policy*, 2022, 12(1), 1-9.
- Raggad, B. (2021). Time varying causal relationship between renewable energy consumption, oil prices and economic activity: New evidence from the United States. *Resources Policy*, 74, 102422.
- Rahman, M. M., & Velayutham, E. (2020). Renewable and non-renewable energy consumption- economic growth nexus: new evidence from South Asia. *Renewable Energy*, 147, 399-408.
- Rehman, A., Ma, H., Ahmad, M., Irfan, M., Traore, O., & Chandio, A. A. (2021). Towards environmental Sustainability: Devolving the influence of carbon dioxide emission to population growth, climate change, Forestry, livestock and crops production in Pakistan. *Ecological Indicators*, 125, 107460.
- Saboori, B., Sulaiman, J. & Mohd, S. (2012). Economic growth and CO2 emissions in Malaysia: a cointegration analysis of the Environmental Kuznets Curve. *Energy Policy*, 51 184-191.
- Saqib, N. (2018). Greenhouse gas emissions, energy consumption and economic growth: Empirical evidence from gulf cooperation council countries. *International Journal of Energy Economics and Policy*, 8(6), 392-400.
- Saudi, M.H.M., Sinaga, O., Roespinoedji, D. & Jabarullah, N.H. (2019). Industrial, Commercial and Agricultural energy consumption and economic growth leading to environmental degradation *Ekoloji* 28 (107) 299-310
- Solarin, S.A.; Ozturk, I. (2016). The Relationship between Natural Gas Consumption and Economic Growth in OPEC Members. *Renew. Sustain. Energy Rev.* 58, 1348–1356.
- Tariq, G. Sun, H., Haris, M., Javaid, H.M. & Jong. Y (2018). Energy Consumption and Economic growth: Evidence from 4 Developing Countries. *American Journal of Multi- disciplinary Research* 7(1) ISSN 2356-6191.
- Ummalla, M., & Samal, A. (2019). The impact of natural gas and renewable energy consumption on CO2 emissions and economic growth in two major emerging market economies. *Environmental Science and Pollution Research*, 26(20), 20893-20907.
- Wang, Q, Su M, Li R, Ponce P., (2019). The effects of energy prices, urbanization and economic growth on energy consumption per capita in 186 countries. *Journal of Cleaner Production*.225:1017-32.
- Zhang, J. and Broadstock, D.C. (2016). The Causality between Energy Consumption and Economic Growth for China in a Time-varying Framework. *The Energy Journal* 37, 29- 53.
- Zhao, Y. & Wang, S. (2015). The Relationship between Urbanization, Economic Growth and Energy Consumption in China: An Econometric Perspective Analysis. *Sustainability*, 7, 5609-5627; doi:10.3390/su7055609.
- Zheng, W. & Walsh, P.P. (2019). Economic growth, urbanization and energy consumption — A provincial level analysis of China *Energy Economics* 80 153-162
- Zhou, X., Sha, J. & Zhong, S. (2015). Economic growth in China: A computable general equilibrium analysis International Conference on Advances in Energy and Environmental Science (ICAEEES 2015).





**IMPACT OF FINANCIAL DEVELOPMENT ON CARBON DIOXIDE EMISSIONS:  
 EMPIRICAL EVIDENCE FROM AZERBAIJAN, RUSSIA, AND KAZAKHSTAN**

Samra Talishinskaya, Economist, +994504320429, [samra.talishinskaya@gmail.com](mailto:samra.talishinskaya@gmail.com)  
 Jeyhun I. Mikayilov, Research Fellow, +996537324174, [Jeyhun.mikayilov@kapsarc.org](mailto:Jeyhun.mikayilov@kapsarc.org)

**Overview**

This paper empirically examines how financial sector development affects the carbon dioxide emissions in economically hydrocarbon dependent three post-Soviet economies - Azerbaijan, Russia, and Kazakhstan. To examine this relationship, we employed cointegration techniques to the data ranging from 1990 to 2019. We found that financial sector development has a positive and statistically significant impact on environmental pollution in all three countries. These empirical findings are in line with the theory. While the impact on carbon emissions was highest for Azerbaijan, it was the lowest for Russia. Considering the chosen countries have resource-dependent economies, as the more developed and liberalized the financial sector becomes, it intermediates investments more to oil-gas-related projects. Moreover, with the improving economic development in these countries under favorable oil prices, the living standards of people increases, and consumers are inclined to spend more on energy consumption intensive areas to enhance their living conditions, which engenders a rise in carbon dioxide emissions. Since information-intensive industries have not yet been established in the chosen countries, economic activities keep posing a negative impact on environmental pollution in the form of carbon dioxide emissions. The implications of the empirical results are discussed for energy and financial development policies.

**Methods**

Our empirical model is constructed as follows:

$$CO2PC=C(0)+C(1)FINDEV+C(2)GDPPC+C(3)OILPRC+C(4)AWA$$

Variable	Symbol	Description	Expected sign	Economic implication
Carbon emission	CO2PC	measured in metric tons per capita	-	-
Financial development	FINDEV	the index is based on (a) domestic credit provided the by financial sector (% of GDP), (b) foreign direct investment, net inflows (% of GDP), and (c) trade (sum of imports and export as a % of GDP)	+/-	If financial development impact is positive on carbon emissions, this means financing is directed to projects which contribute to environmental pollution. If this impact is negative, it means the financial sector helps companies to run financing more into green projects.
GDP per capita	GDPPC	GDP per capita in current USD	+	A higher level of GDP per capita increases carbon emissions. Considering the economic structure of the studied countries, we assume a positive linear impact of income on CO2 emissions.
Oil prices	OILPRC	Europe Brent Spot Price FOB (USD per Barrel)	+/-	When oil prices increase, oil-exporting countries are prone to either spending carelessly or investing in eco-friendly projects. Thus, the change in this variable may have both positive and negative impacts on carbon dioxide emissions.
Awareness of climate urgency	AWA	individuals using the internet as a percent of the population	+/-	If positive, though people are aware of climate change, they keep using fuel dominant means. If negative, it means, people are conscious of climate urgency and adopting environmentally friendly behavior.







All variables are used in a logarithmic form. We analyze the relationship between CO<sub>2</sub> emission, financial development, oil price, awareness, and GDP per capita variables using the Dynamic Ordinary Least Squares (DOLS) technique (Stock & Watson, 1993). First, we checked the non-stationarity characteristics of selected variables. We used Augmented Dickey-Fuller (ADF, (Dickey & Fuller, 1981)) unit root test and Phillips-Perron test (PP, (Phillips & Perron, 1988)). Next, we can proceed to the cointegration test to analyze whether the variables move together in the long run. For this purpose, we used the Engle-Granger test (Engle & Granger, 1987) (cite it) for cointegration. After confirming the cointegration, we applied DOLS to investigate the long-run relationship among the variables.

## Results

Results of empirical estimations show that financial development has a positive and statistically significant impact on carbon emissions for all three selected countries, which is in line with the findings of many papers (Sadorsky, 2010, 2011; Ali et al., 2018; Ma and Fu, 2020, among others). This finding allows us to conclude that, amid the development period of a country, where environmental quality is not a priority, betterment in the relatively easy access to finance "motivates" further consumption. The additional eco-unfriendly consumption results in environmental degradation.

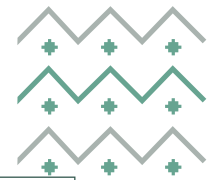
We found that a 1% increase in financial development resulted in a 0.47%, 0.19%, and 0.30% rise in carbon dioxide emissions, respectively, in Azerbaijan, Russia, and Kazakhstan. Empirical results show that for Azerbaijan financial development and oil price, for Russia oil price and GDP per capita, and for Kazakhstan GDP per capita and financial development have the highest by the impact on carbon emissions. The impact of oil price was negative and statistically significant, GDP per capita was positive and statistically significant. While awareness of the population about climate urgency was negative and statistically significant for Azerbaijan and Kazakhstan, and it was positive and statistically significant for Russia. Overall, economic growth and financial sector liberalization raise carbon emissions, and oil prices and citizens' awareness about environmental degradation have a negative impact, as expected.

## Conclusions

In this study, we investigated the impact of financial development on carbon dioxide emissions using DOLS for three post-Soviet countries – Azerbaijan, Russia, and Kazakhstan – with similar economic development and structure. The unit root exercises for variables of interest displayed their stationarity at first differenced form. Next, variables were tested for the long-run relationship by employing the Engle-Granger test for cointegration. The obtained results show the validity of cointegration among variables which implies the existence of a long-run relationship between financial development and carbon dioxide emissions in selected countries. The empirical results indicated that by employing the DOLS technique, financial development proxied by respective index built on credit to GDP, foreign direct investment, and trade balance could increase carbon dioxide emissions. Numerically, a 1% increase in financial development results in a 0.47%, 0.19%, and 0.30% rise in carbon dioxide emissions, respectively, for Azerbaijan, Russia, and Kazakhstan. Moreover, economic development also leads to an increase in environmental pollution. At the same time, oil prices and awareness of the population of climate urgency and changing their behavior have decreasing influence (except Russia) on carbon emission.

Based on the empirical results, we conclude the following policy implications. First, financial sector development is a lubrication channel for improving economic development; nevertheless, considering the calls for climate change, a "greener" investment approach should be adopted for alleviating carbon emissions and achieving sustainable and resilient economic growth. This is a crucial point for policymakers to consider when formulating energy and financial development policies. We performed a robustness check and verified the reliability of the results. As a part of the robustness exercise, we used several cointegration methods, but the results received by the DOLS technique outperformed results produced by other techniques. We also used other financial sector development proxies (domestic credit to private sector by banks (% of GDP) and foreign direct investment, net inflows (% of GDP)), and various control variables such as urban population growth (annual %), fossil fuel energy consumption (% of total). It would be interesting for future research to investigate similar relationships in the case of other oil-exporting countries.





## Submission Summary

**Conference Name**

44th IAEE International Conference - 2023

**Paper ID**

40

**Paper Title**

The Role of Civil Law in Environmental Protection For the Suez Canal Axis Development Project an Applied Study of the Localization of Green Hydrogen to Achieve Sustainable Development in Egypt by Farouk M. Abdel Rahman and Mohamed El- Esawy Ahmed Atomic Energy Authority, Nuclear and radiological center, Egypt

**Abstract**

Research Summary

The main objective of the Suez Canal Axis Development Project is to promote economic growth and sustainable development in Egypt during the coming years. An integrated study should be conducted on the competitiveness of this project in similar regions of the world and determine the priority of the industries that will include it to determine the added value and competitive advantages of that project, which is considered the dream that Egyptians seek to implement. So the Egyptian government should provide an enabling environment for investment, including the private sector, the optimal utilization of available resources and the modernization of the regulatory framework. The goal is not only to transform the Suez Canal axis area into a global logistics zone for maritime transport by duplicating the Suez Canal transit and construction of the ports of Ain Sokhna and East Port Said, But also, a global zone for value-added and environmentally friendly industries. These industries such as the localization of the green hydrogen industry in the region. This is done under the United Nations Sustainable Development Agenda until 2030.

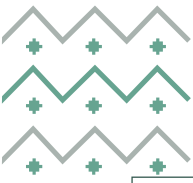
Regarding the localization of the green hydrogen industry, the aim is to establish production projects in the region, because of their close link with the pivotal ports around it. As the global demand during the coming short period will witness a significant increase in low-carbon fuels. In light of the current global data on reducing carbon emissions, within the plans of countries to shift towards a green economy, which makes the opportunity to put Egypt in a position of regional leadership in the production, use and export of this environmentally friendly fuel, ahead of Egypt's hosting of the COP27 climate summit to be held Year 2022.

Egypt has the basic elements to localize and expand this project depending on its will and political support to shift towards a green economy and the huge potential to produce this fuel at competitive prices. In addition, the privileged geographical location of Egypt and its proximity to the continent of Europe, which is the most important markets importing clean energy products. Moreover, Egypt has the necessary infrastructure to export it to European countries, depending on the natural gas export network. As well as another competitive advantage is the passage of about 15% of global shipping traffic through the Suez Canal. It offers huge opportunities to raise its competitiveness by turning it into a global hub for bunkering for green energy

This is from an economic point of view, but the real problem is the risks of storing and transporting it as hydrogen is fast exploding and can cause dangers to residential communities around the project. So the legal structure updated to compensate the third party commensurate with the damages that can occur. In addition, this presented in this research. In terms of presenting the existing legal structure, how and what are the methods of modernization and how the third party gets compensation for the damages suffered by them through strict liability or liability Strict fault based on the absence of fault and not fault-based tort in civil law.

Green hydrogen is receiving great global attention and Egypt is not the first in the Arab world. It is proceed by the UAE and Saudi Arabia, as a promising source of energy in the near future. The green hydrogen is a carbon-free fuel, sourced from water, by separating hydrogen molecules from oxygen molecules by electrolysis. Thus combating global





Conference Management Toolkit - Submission Summary

<https://cmt3.research.microsoft.com/IAEEConference2023/Submissio...>

warming by reducing the proportion of carbon in the air, if this electricity obtained from renewable sources such as natural gas currently available in Egypt, we will produce energy without emitting dioxide Carbon in the atmosphere where it can produce at the lowest costs.

---

**Created on**

8/22/2022, 6:09:19 PM

---

**Last Modified**

8/22/2022, 6:09:19 PM

---

**Authors**

**Farouk Rahman** ( Atomic energy Establishment ) < farouk6347@hotmail.com > ✓

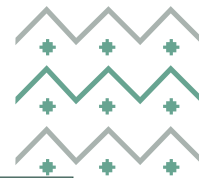
---

**Primary Subject Area**

Energy and the Environment

---





## *Analyzing the impacts of technological innovation on CO2 emission "Innovation Claudia Curve Theory (ICC)" in MENA Countries*

Nouf Alnfishah<sup>1</sup>, Eman Alsmari<sup>2</sup>, Amal Alshehri<sup>3</sup>

<sup>1</sup> Lecturer at Princess Noura University and PhD candidate in economics in King Saud University, [tel:0545582200, noufsaud1506@gmail.com](mailto:noufsaud1506@gmail.com).

<sup>2</sup> Lecturer, Department of Economics, Princess Noura University, [tel:0541665882, EAAlsmari@pnu.edu.sa](mailto:EAAlsmari@pnu.edu.sa)

<sup>3</sup> Lecturer, Department of Economics, Princess Noura University, [tel:0503277298, amal\\_alshehri@hotmail.com](mailto:amal_alshehri@hotmail.com).

### Overview:

In recent years, due to the serious effects on the environment, there have been intense discussions about concepts that refer to the destruction of the environment, such as global warming and climate change. Accordingly, the Environmental Kuznets Curve (EKC) hypothesis, which was proposed by Kuznets (1955) to deal with the effects of economic growth on environmental destruction, has become a popular research topic. Furthermore, the concept of technological innovation is attributed to Schumpeter (1942) and most researchers believe that change in technological innovations has a vital importance in explaining and addressing key issues in the environment.

This study not only examines economic growth in terms of environmental impact, but also adopts a modified EKC theory to investigate the impact of technological innovation and consumption of renewable and non-renewable energy on significantly increasing CO2 emissions in selected MENA countries. Thus, this paper will be particularly useful for decision makers to help them adopting policies that contribute to promoting technological innovations to reduce these emissions and their negative effects on the environment, especially since most of these countries use non-natural resources in their economic growth.

Several empirical studies have been conducted in various countries to investigate the variables that affect the environment. In this context, Vo and Vo (2021) emphasized that sustainable economic growth in the ASEAN region is accomplished by moderating population growth with higher use of renewable energy, in addition, renewable energy usage responds to population growth and leads to CO2 emissions. Moreover, many studies have found a causality between economic growth, energy consumption and CO2 emissions (Tzeremes, 2018; Vo and Vo, 2021).

In term of MENA country there have been many studies investigate the importance of reducing the CO2 emissions by studying various variables such as Alharthi et al. (2021) concluded that economic growth destroys the environment while renewable energy reduces carbon emissions. Moreover, S. P. Nathaniel et al. (2021) tested the Environmental Kuznets Curve (EKC) theory in the MENA region and pointed out that there is existence of a bidirectional causal connection in both the short and long term between energy consumption and economic growth. In terms of policy effectiveness Kahia et al. (2017) found that renewable energy policies have a significant and positive effect on encouraging and helping the economy grow.

Recently, technological innovation has been incorporated as a new indicator into the growth-environment framework, as it is recognized as an important component in the reduction of CO2 globally. Extant research has been done on how innovations affect carbon emissions. For example, Khan et al. (2020) revealed that technological innovation diminishes CO2 emissions in China. Meanwhile, Mensah et al. (2018) showed that technological innovation plays a key role in mitigation of CO2 emissions and enhances environmental quality.

### Methods:

This study will adopt the modified innovation EKC model (Innovation Claudia Curve theory) to analyze the effect of innovation technology on CO2 emissions and examine the existence of an inverted U-shaped curve between innovation and environmental quality in selected MENA countries., the model is shown as follows:

$$CO2_{it} = \alpha_0 + \beta_1 GDP_{it} + \beta_2 GDP^2 + \beta_3 PAT_{it} + \beta_4 PAT^2_{it} + \beta_5 NPAT_{it} + \beta_6 NPAT^2_{it} + \beta_7 REC_{it} + \varepsilon_{it}$$

The paper will focus on only 6 MENA countries due to availability of data these countries are: Algeria, Egypt, Iran, Morocco, Saudi Arabia, Tunisia. from 1990 to 2019.

The main variables for the study are CO2 emission per capita (as dependent variable) and innovation as independent variable (PAT as a measure of patent application by resident and NPAT as non-resident). This proxy for innovation has been employed by (Chuzhi & Xianjin, 2008; Khan et al., 2021) and came





to the same conclusions proving that patents have a beneficial effect on CO<sub>2</sub> emissions. Also, our study further added the following explanatory variables: GDP is gross domestic product per capita (constant 2015 US\$), REC is renewable energy consumption (renewable energy consumption % of total final energy consumption), while  $\varepsilon$  is the error term. In addition, in empirical analysis. Thus, this paper uses the panel FEM, EGLS estimation methods.

#### Empirical result:

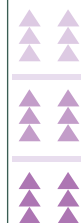
This paper aims to assess the modified innovation EKC model (Innovation Claudia Curve theory) and analyze the effect of using renewable energy, economic growth, and innovation technology on CO<sub>2</sub> emissions. In addition, it attempts to examine the existence of a U-shaped curve between innovation and environmental quality in a selected MENA country for 1990–2019 by applying the panel Fixed effect (FE) and generalized least squares (EGLS) estimation methods. The empirical econometric results reveal that the Innovation Claudia Curve (ICC) is valid for the selected countries, and the quadratic patent variable shows that initially the use of innovation technology increases emissions, but after a certain level, a turning point occurs, and patents have a significant impact on environmental quality. Thus, the results support the idea that as more patents are developed and used, the quality of the environment improves and the levels of environmental degradation decrease.

In a panel study, we looked at how innovation affects carbon emissions. After confirming the cross-section dependents between countries, we begin to verify the stationarity of the data by using second-generation panel unit root tests to determine the stationarity of the variables. According to the results of the CIPS panel unit root tests, CO<sub>2</sub>, GDP, PAT,  $PAT^2$  and NPAT,  $NPAT^2$  are non-stationary at levels but become stationary at first differences, whereas the REC is stationary at levels. Then, testing for cointegration gives us another way to look at how variables are connected. The cointegration test by Westerlund (2007) is used to deal with the problem of heterogeneity and cross-sectional dependencies. The outcomes show the results of no cointegration between variables.

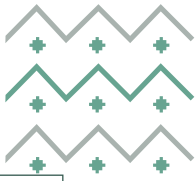
In the empirical approach, we estimate the model by using two methods: fixed affect (FE) and generalized least squares (EGLS). The results from the fixed-effect model show that GDP, PAT, and  $PAT^2$  are statistically significant, which illustrates that the impact of GDP on carbon emissions is negative and significant. And the square of GDP has a significant positive impact on CO<sub>2</sub> emissions, which conforms to the existence of Kuznets's curve in MEANA countries. This finding is consistent with other studies that hypothesize the existence of the Kuznets curve, such as (Nathaniel, Adeleye, and Adedoyin 2021). On the other hand, the renewable energy consumption is positive but not significant, whereas with the resident patent it is positive and significant, expressing the impact of the patent on the carbon emission. The patent square demonstrates a significant negative relationship with carbon emissions, confirming the Claudia theory's inverse U-shape. Where, according to the Claudia Curve theory, increasing carbon will be mitigated by technologies (innovations), the first will initially increase emissions due to limited accessibility, but further increases will gradually lower emissions. When more technologies are protected by patents, high technology spillovers will reduce CO<sub>2</sub> emissions. Finally, the nonresident patent has no impact on reducing carbon emissions. In comparison to EGLS methods, where all variables are statistically significant, the Kuznets model does not exist here, where GDP and GDP square have a positive sign, which means that increasing GDP by one unit leads to an increase in CO<sub>2</sub> emissions by 0.0005, which is a very small impact. The consumption of renewable energy is negative, with a 0.02 reduction in CO<sub>2</sub> when consuming a unit of renewable energy. The paper's focus is on innovation and its impact on improving environment quality where the resident patent has the inverse Claudia U curve, while the nonresident patent has a U shape.

#### Conclusion:

The results from our analysis are confirmed the validity of Claudia curve theory (ICC). The findings reveal the impact of technological innovation on mitigating the level of CO<sub>2</sub> emission in selected MENA countries, indicating the positive relationship between patent and CO<sub>2</sub> emission on one side. Furthermore, the quadratic patent variable illustrates a negative relationship with CO<sub>2</sub> emission. In other words, the use of technologies initially causes environmental degradation, but beyond a certain degree of discovery of more patents the quality of the environment improves and the levels of environmental degradation decrease.







## **LITHIUM & BATTERY METALS REFINING – NEW OPPORTUNITIES IN THE REFINING INDUSTRY**

Lukasz Bednarski, IHS Markit (part of S&P Global), +447842712082, lukasz.bednarski@ihsmarkit.com

### **Overview**

Minerals used in lithium-ion batteries powering electric vehicles need to be refined before ending up in the cell. Lithium and battery materials refining is an industry that developed already on the large scale in China but it is still in its early stages of development in other parts of the world. While transition into electric vehicles will require regionally situated lithium refineries serving local markets to minimize CO<sub>2</sub> emissions during transportation of refined lithium, as well as quality losses. Decreasing reliance on China as a single point of supply is also important for the security of European and North American supply chains. Opportunities for construction of lithium refineries in GCC countries arise.

### **Methods**

Surveys, semi-structured interviews, proprietary developed forecasting models.

### **Results**

Our forecasts point out to global shortage of refined lithium chemicals already in 2026 if more lithium refining capacity is not announced.

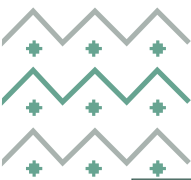
### **Conclusions**

Shortage of refined lithium chemicals, presents commercial opportunities for development of lithium hydroxide refineries. Such pioneering endeavours, however are not without risks. The presentation will highlight the findings of our research on lithium & battery materials refining – including risks and opportunities related to participation in this industry. It will broadly present the opportunities for development of battery refining industry in GCC countries.

### **References**

Big shovels – Can battery materials supply keep pace with demand? L.Bednarski, J.Meyer, G.Hilton, S. Wilkinson, Strategic report, IHS Markit (now a part of S&P Global), 2022





## ***Impact of non-tailpipe emissions on local air pollution: Evidence from New Zealand***

Mingyue Selena Sheng, Energy Centre, University of Auckland  
Le Wen\*, Energy Centre, University of Auckland, Phone +64 9 923 7594, E-mail: [l.wen@auckland.ac.nz](mailto:l.wen@auckland.ac.nz)  
Quan Truong, Department of Property, University of Auckland  
Perry Davy, GNS Science, Wellington, New Zealand

### **Overview**

Road transport is one of the primary sources of airborne particulate matter (PM), a common class of pollutant in urban environments and a primary driver of air pollution's burden of disease worldwide.<sup>1</sup> PM concentrations differ in particles' sources and chemical composition<sup>2</sup> affected by locations and meteorological conditions, such as temperature, humidity, wind speed, and rainfall<sup>3</sup>. While transformational technological improvements, coupled with emission control regulations and policies have led to a substantial reduction in exhaust emissions (EMs) from road traffic<sup>4-6</sup>, currently, on-road non-exhaust emissions (NEEs), also known as NEEs such as those generated from brake, tyre, clutch and road surface wear or road dust resuspension due to traffic congestion are unabated<sup>7</sup>. Most recent data show a number of European cities including Berlin and London indicated that the contribution of NEEs to PM concentrations was comparable or even larger compared to EMs<sup>8</sup>. Empirical evidence from Auckland also indicates that coarse PM has become the dominant transport source after 2016, as NEEs increase in line with rising traffic volume<sup>9</sup>. However, NEEs of PM constitute a little-known knowledge and hence has been downplayed compared to EMs in the literature and transport and health policies.

EVs can improve air quality through zero tailpipe emissions<sup>10</sup>. However, fleet electrification would not significantly reduce PM emissions, as 1) NEEs in transport arise irrespective of the fuel source, and 2) the ever-increasing proportion of non-exhaust emissions in the total emission profile<sup>11</sup>. Hence, expanding the share of alternative fuel vehicles in the overall fleet will unlikely reduce PM pollution. To the contrary, PM pollution may in fact increase due to heavier vehicle weights<sup>12</sup>. For this reason, an improved understanding of the relationship between the sources and causes of particulate NEEs and vehicle characteristics is vital for developing appropriate policy interventions to tackle this issue.

Hence, the aim of this research is to explore and better understand the nexus between NEEs and the vehicle fleet and its implications for human health, based on econometric analysis of detailed New Zealand centric data. In particular, we are interested in: 1) quantifying the impacts of potential sources on monitored NEEs, and 2) propose specific policy recommendations in order to improve the country's air quality.

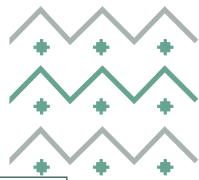
### **Methods**

The study utilises panel data regression to examine the impact of road dust and other factors, including soil, biomass, fuel, and marine aerosol, after considering the meteorological data, such as wind speed, temperature, and humidity.

### **Results**

- Accordingly, five factors, including soil, biomass, fuel, marine aerosol, and road dust were found statistically significant at the 1% level, while secondary sulphate was significant at 10% level. All the coefficients are positive, implying that 1% increase in soil and road dust will increase 6.2% and 4.9% of PM10, respectively.
- After adding the interaction between soil and road dust given the fixed effects, interestingly, both road dust and soil were found to be significant at 1% and 5% level,





respectively. In addition, the interaction between these two variables was also significant at 1% level. It suggests that soil, jointly with road dust, positively influences the concentration of PM10.

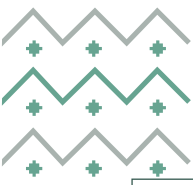
### Conclusions

The empirical results of our research would be twofold. First, they would provide the necessary and scientifically based evidence to assist urban/transport planners and policymakers in understanding the long-ignored relationship between NEEs and the vehicle fleet, in New Zealand. And second, the assessment of transport policy impacts will also offer a cost-effective way to reduce NEEs, and identify policy drawbacks before any legislative changes. Our findings will be highly relevant for transport and environmental policies.

### References

1. Health Effects Institute. (2020). State of Global Air 2020. Special Report. Boston, MA: Health Effects Institute. Retrieved from: <https://www.stateofglobalair.org/>
2. Davy, P.K., Ancelet, T., Trompetter, W.J., Markwitz, A. & Weatherburn, D.C. (2012). Composition and source contributions of air particulate matter pollution in a New Zealand suburban town. *Atmospheric Pollution Research*, 3(1),143-147. <https://doi.org/10.5094/APR.2012.014>
3. Patel, H., Talbot, N., Salmond, J., Dirks, K., Xie, S. & Davy, P. (2020). Implications for air quality management of changes in air quality during lockdown in Auckland (New Zealand) in response to the 2020 SARS-CoV-2 epidemic. *Science of the Total Environment*, 746, 141129. <https://doi.org/10.1016/j.scitotenv.2020.141129>
4. Wen, L., Sheng, M., & Sharp, B. (2021). The impact of COVID-19 on changes in community mobility and variation in transport modes. *New Zealand Economic Papers*. <https://doi.org/10.1080/00779954.2020.1870536>
5. Sheng, M., Sreenivasan, A.V., Sharp, B., Wilson, D. & Ranjitkar, P. (2020). Economic analysis of dynamic inductive power transfer roadway charging system under public-private partnership—Evidence from New Zealand. *Technological Forecasting and Social Change*, 154, 119958. <https://doi.org/10.1016/j.techfore.2020.119958>
6. Yi, M., Wang, Y., Sheng, M., Sharp, B., & Zhang, Y. (2020). Effects of heterogeneous technological progress on haze pollution: Evidence from China. *Ecological Economics*, 169, 106533. <https://doi.org/10.1016/j.ecolecon.2019.106533>
7. Thorpe, A. & Harrison, R.M. (2008). Sources and properties of non-exhaust particulate matter from road traffic: A review. *Science of The Total Environment*, 400(1-3), 270–282. <https://doi.org/10.1016/j.scitotenv.2008.06.007>
8. Querol X., Alastuey A., Ruiz C.R., Artinano B., Hansson H.C., Harrison R.M, Buringh E., ten Brink H.M., Lutz M., & Bruckmann P. (2004) Speciation and origin of PM10 and PM2.5 in selected European cities. *Atmospheric Environment*, 38(38), 6547-6555. <https://doi.org/10.1016/j.atmosenv.2004.08.037>
9. Soret, A., Guevara, M. & Baldasano, J. (2014). The potential impacts of electric vehicles on air quality in the urban areas of Barcelona and Madrid (Spain). *Atmospheric Environment*, 99, 51-63. <https://doi.org/10.1016/j.atmosenv.2014.09.048>
10. Davy, P., K. & Trompetter, W. J. (2019). Composition, sources and long-term trends for Auckland air particulate matter: Summary Report. GNS Science Consultancy Report 2019/151.
11. Air Quality Expert Group. (2019). Non-Exhaust Emissions from Road Traffic. [https://ukair.defra.gov.uk/assets/documents/reports/cat09/1907101151\\_20190709\\_Non\\_Exhaust\\_Emissions\\_typeset\\_Final.pdf](https://ukair.defra.gov.uk/assets/documents/reports/cat09/1907101151_20190709_Non_Exhaust_Emissions_typeset_Final.pdf)
12. Timmers, V.R.J.H. & Achten, P.A.J. (2016). Non-exhaust PM emissions from electric vehicles. *Atmospheric Environment*, 134, 10-17. <https://doi.org/10.1016/B978-0-12-811770-5.00012-1>





***PUBLIC UTILITIES' CORPORATE GROWTH AND ENVIRONMENTAL CONSERVATION: EVIDENCE FROM JAPAN***

Dr. Masao TSUJIMOTO

Associate Professor, Japan University of Economics

Phone: +81-3-3463-4112, Email: masao.tsujimoto@gmail.com

**Overview**

This presentation explores how public utilities in Japan have achieved both growth and environmental conservation by using financial performance and environmental impact data from publicly traded companies of power, gas, transport, telecommunication, and postal services. First, the regression analyses confirm the Environmental Kuznets Curve (EKC) hypothesis and an inverted N-shaped curve. Second, the growing trend of Environment, Society, and Governance (ESG)-oriented investment and management are deciding factors; they have acted as competitive pressure on the public utilities for fundraising, especially in spurring them to disclose information before and during the COVID-19 pandemic. Third, further consideration based on ESG and total shareholders return (TSR) could contribute not only to environmental conservation but also to academic frontier expansion.

**Methods**

This presentation verifies the relationship between the financial performance and environmental impact data of 43 stock-listed public utilities in Japan, employing linear, quadratic, and cubic regressions. This approach differs from previous studies in that the EKC and its advanced theory of the inverted N-shaped curve are applied to companies through accounting, rather than the conventional and traditional approach applied to countries. Sources include both ESG reports and annual securities reports in Japanese, which are equivalent to US Form 10-Ks.

- Of the 3,830 companies listed on the Tokyo Stock Exchange as of July 31, 2022, 43 were chosen from the electricity, gas, transportation, telecommunications, and postal services for which environmental data are available. However, because some companies do not disclose some of their environmental data, the calculation may be based on fewer than 42 companies.

- Dependent variables: 16 = 8 x 2 [both cases are divided and not divided by persons (per staff member)].

- Total CO<sub>2</sub> emissions (CO<sub>2</sub>),
- Scope 1 CO<sub>2</sub> emissions (SCP1),
- Scope 2 CO<sub>2</sub> emissions (SCP2),
- Scope 1+2 CO<sub>2</sub> emissions (SCP1+2),
- Scope 3 CO<sub>2</sub> emissions (SCP3),
- electricity consumption (ELC),
- water consumption (AQU), and
- industrial waste generation (WST).

There are both patterns in which it is calculated on a per staff member basis and not; 8 patterns for the former and 8 patterns for the latter, for a total of 16 patterns.

- Explanatory variables: 14 = 7 x 2 (both cases are divided and not divided by persons).

- net sales (SAL),
- net income (INC),
- earnings per share (EPS),
- total assets (SST),
- property, plant, and equipment (PEQ),
- treasury stocks (RES), and
- total shareholders return (TSR).

As in the dependent variables, both cases are a per staff member basis and otherwise; that is, there are 7 patterns for the former and 7 patterns for the latter, for a total of 14.

- The total number of regression formulas is 672. The breakdown is as follows; the number of linear equations is 112 = 8 (dependent variables) x 7 (explanatory variables) x 2 (both cases divided by persons and not). The number of quadratic equations is 112 and that of cubic is 112 in 2019. The number of formulas for linear, quadratic, cubic in 2020 is 112, respectively, the same as in 2019. So, (112 x 3) x 2 (2019 and 2020) = 672.

- Environmental data for 2021 had not been disclosed by each company at the time of this application (September 2022). Because the data will be available after October 2022, the author intends to present the calculation results, including the 2021 data, in the upcoming presentation in February 2023.

The significance level of the p-value is set at 5% (p < 0.05). Then, the regression models are as follows.

First, where CO<sub>2</sub> emission is the dependent variable and each variable from (1) SAL to (7) TSR is placed as the explanatory variable.

$$Y(\text{CO}_2) = \alpha + \beta_1(\text{SAL}) + \epsilon, \tag{1-1-1}$$

$$Y(\text{CO}_2) / \text{persons} = \alpha + \beta_1(\text{SAL}) / \text{persons} + \epsilon, \tag{1-1-1P}$$

The order of the explanatory variables is the same as above, only replacing the dependent variable, while equations (2)–(8) are omitted.

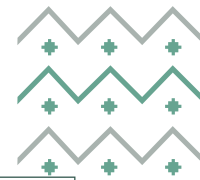
Second, the Environment Kuznets Curve (EKC) hypothesis is examined. The hypothesis is valid when the linear term (positive: β > 0) and the squared term (negative: β < 0) are significant (p < 0.05).

$$Y(\text{CO}_2) = \alpha + \beta_{11}(\text{SAL}) + \beta_{12}(\text{SAL})^2 + \epsilon, \tag{1-1-2}$$

$$Y(\text{CO}_2) / \text{persons} = \alpha + \beta_{11}(\text{SAL}) / \text{persons} + \beta_{12}(\text{SAL}) / \text{persons}^2 + \epsilon, \tag{1-1-2P}$$







Third, the success or failure of a cubic curve is tested. It is desirable to illustrate an inverted N-shaped curve in investigating the relationship between growth and environmental impact. The inverted N-shape is valid in cases wherein the environmental impact increases (positive:  $\beta > 0$ ) at the first turning point (bottom), it decreases (negative:  $\beta < 0$ ) at the second turning point (top).

$$Y(\text{CO}_2) = \alpha + \beta_{11}(\text{SAL}) + \beta_{12}(\text{SAL})^2 + \beta_{13}(\text{SAL})^3 + \varepsilon. \quad (1-1-3)$$

$$Y(\text{CO}_2) / \text{persons} = \alpha + \beta_{11}(\text{SAL}) / \text{persons} + \beta_{12}(\text{SAL}) / \text{persons}^2 + \beta_{13}(\text{SAL}) / \text{persons}^3 + \varepsilon. \quad (1-1-3P)$$

## Results

This study's findings are as follows. First, linear regression analysis reveals significant monotonic relationships in 15 cases (13.4%) and 27 cases (24.1%) of the 112 cases tested in 2019 and 2020, respectively. The results illustrate a trend in which when financial performance expands, environmental impact increases in the both years. Second, quadratic regression analysis of the EKC hypothesis confirms the validity of 15 cases (13.4%) in 2019 and 10 cases (8.9%) in 2020 out of the 112 cases tested. Third, the inverted N-shaped curve analysis confirmed the validity of 1 case (0.9%) in 2019 and 1 case (1.0%) in 2020 out of the 112 cases tested.

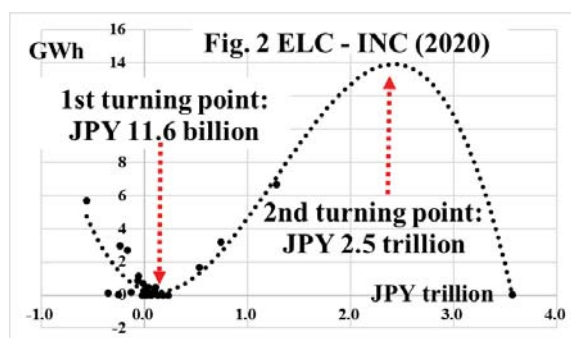
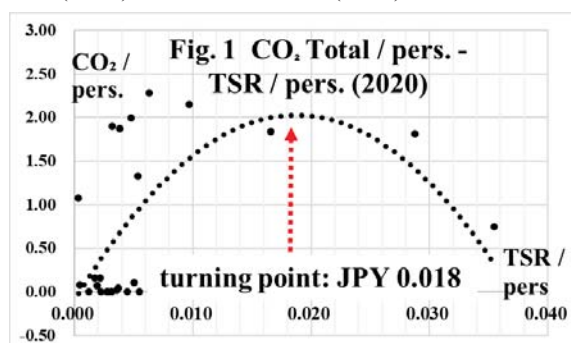


Fig. 1 illustrates the explanatory variables (TSR / persons) on the X-axis, while the dependent variables (CO<sub>2</sub> total / persons) are on the Y-axis, revealing that the relationship depicts an inverted U-shaped curve with the turning point. And Fig.2 also illustrates the explanatory variables (INC) on the X-axis, while the dependent variable (ELC) are on the Y-axis, depicting an inverted N-shaped curve with the turning points.

Detailed results and further discussion of their underlying factors will be provided in the 2023 presentation; as for the significant cases confirmed in the EKC and the inverted N-shaped curve, ESG-oriented investment and management should be noted. Investors' emphasis on ESG has been functioning as the compelling or driving force to advance the implementation of environmental conservation.

Moreover, total shareholder return (TSR) accounted for 6 (24.0%) of the 25 EKC hypotheses established in 2019 and 2020. TSR is calculated based on dividends, capital gains, etc. divided by the amount invested. Furthermore, firms above or near the 0.018 level are not necessarily among the top-ranked firms in terms of net sales, but rather among the middle or low-ranked firms. Therefore, TSR can be the key to establishing the

EKC hypotheses, that is, realizing environmental conservation. The emergence of the turning points in Figures 1 and 2 indicates the birth of the growth and environmental impact decoupling. The increasing TSR to thresholds, that is, JPY 0.018 in the EKC, could serve as guidelines or benchmarks for decoupling.

Finally, the disclosure of TSR has just begun with the 2019 amendment of the Cabinet Office Order on Disclosure of Corporate Affairs in Japan. Previous studies have almost never used TSR to analyze environmental data; a TSR analysis in this presentation could contribute to expanding the research frontier not only in Japan but also in other countries.

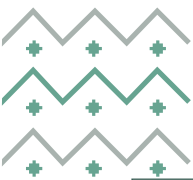
## Conclusions

A TSR- and ESG-focused approach demonstrated in this presentation could contribute toward expanding the frontiers of environmental economics and industrial organization theory, and environmental conservation. Therefore, it is recommended that the academic community keep exploring the relationship between growth and environmental conservation.

## References

- Each company, *Environmental / ESG Reports and Annual Securities Reports*.  
 Tsujimoto, M (author). (2022) Conservation of the Global Environment by Developing Digital Platforms - As a Preliminary Perspective, *IAEE Energy Forum, 3rd Quarter, 2022*. <https://www.iaee.org/newsletter/issue/113>.  
 \* Masao TSUJIMOTO is an IAEE member and has presented at the IAEE International Conferences in 2017, 2019, and 2022. He was also in charge as a session chair at the 2022 Conference in Tokyo.





## ***DETERMINANTS OF CARBON DIOXIDE EMISSIONS: ROLE OF RENEWABLE ENERGY CONSUMPTION, ECONOMIC GROWTH, URBANIZATION AND GOVERNANCE***

Jacob Otim, Kyambogo University, Phone: +256772831133, Email: [jotim@kyu.ac.ug](mailto:jotim@kyu.ac.ug)  
Susan Watundu, Makerere University Business School, Phone: +256782658703, Email: [swatundu@mubs.ac.ug](mailto:swatundu@mubs.ac.ug)  
John Mutenyo, Makerere University, Phone: +256750504217, Email: [jkmutenyo@yahoo.com](mailto:jkmutenyo@yahoo.com)  
Vincent Bagire, Makerere University Business School, Phone: +256772433670, Email: [ybagire@mubs.ac.ug](mailto:ybagire@mubs.ac.ug)

### **Overview**

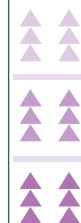
Environmental pollution is one of the leading global debates, and an existential threat to humanity, due to the rise in the global average temperature (IPCC, 2019). The increase in temperature is associated with the meltdown of glaciers, especially in the high mountains of Asia (Rounce et al., 2020). In East African Community (EAC) countries (Kenya, Tanzania, Uganda, Rwanda, and Burundi), the average temperature is projected to rise due to continuous warming in the Indian-Pacific warm pool with a devastating effect on the loss of animals, crops and biodiversity (Niang et al., 2015). There have been attempts to comprehend the causes of environmental degradation in the empirical literature. The seminal work of Grossman and Krueger (1991) provides a deeper examination of the effects of pollution on the environment. They examined the scale effect, composition effect and technique effect as mechanisms that affect the level of pollution and deterioration of environmental assets. The primary research questions for the present study are twofold, What are the drivers of CO<sub>2</sub> emissions in EAC countries? What kind of causal connection exists between CO<sub>2</sub> emissions, the use of renewable energy, governance, urbanization, and economic growth in the EAC countries? The current study differs from many past studies as follows: it examines the determinants of environmental pollution using a multi-theoretical approach based on the EKC theory and STIRPAT model making it more robust (Liddle, 2015). Second, the standard Kuznets curve pollution of income model for the environment and STIRPAT model are integrated and broadened to take into account governance which has been ignored in EAC countries and beyond. By looking at how governance affects CO<sub>2</sub> emissions for EAC countries, this study fills in this vacuum. Third, the study tested for common unobserved factors across EAC countries and applied the second generational panel unit root test, which yields estimates that are more accurate, effective, and robust in the presence of cross-section dependence (CD). Four, the study avoids omitted variable bias by using a multivariate framework.

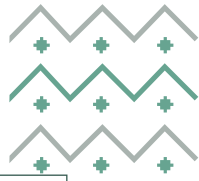
### **Methods**

The study used a panel data spanning from 1996 to 2019 to examine the drivers of CO<sub>2</sub> emissions in EAC countries. Fully Modified Ordinary Least Squares (FMOLS) and Dynamic Ordinary Least squares (DOLS) estimators were employed in the study. The study's findings verified the bell-shaped EKC hypothesis. The bridged environmental Kuznets curve and stochastic regression on population, affluence, and technology models are used in the current study. Before estimating DOLS and FMOLS we first checked for cross-sectional dependence, panel unit roots, and cointegration.

### **Results**

The study's findings verified the bell-shaped EKC hypothesis. In addition, using renewable energy and improving governance is key to lowering the CO<sub>2</sub> emissions in EAC countries, while urbanization promotes CO<sub>2</sub> emissions. The bidirectional causal associations are exhibited between urbanization and CO<sub>2</sub> emissions; governance and CO<sub>2</sub> emissions; GDP per capita and urbanization; consumption of renewable energy and urbanization; and governance and urbanization. In addition, a single-way causal relationship runs from CO<sub>2</sub> emissions to renewable energy consumption; from GDP per capita to CO<sub>2</sub> emissions; from renewable energy consumption to governance; and from GDP per capita to renewable energy consumption.





## Conclusions

The study tested for the drivers of CO<sub>2</sub> emissions in EAC countries using DOLS and FMOLS. The study's empirical findings enable some enlightening deductions that could have important policy ramifications. EAC countries have an estimated population of 300 million and a combined Gross Domestic Product (GDP) at market prices of USD 278.1 billion (EAC, 2022). Economic growth associated with regional integration is likely to increase pollution levels now and in the future, and if nothing is done, there will be no climate change reversal (Espoir et al., 2022). However, the effects of global warming have a significant impact on the population (Kimaro and Mogaka, 2020). The demand for hydrocarbons will continue to rise under the economic regional integration (Pasara, 2019) and in turn, will result in more pollutant emissions. The scale effect based on the EKC, the increase in production will be associated with an increase in pollution but the remedy is to use green energy in the production process to curtail the level of stock pollutants. To address this, more money needs to be spent on renewable energy research and development, including wind, solar, hydro, geothermal, and nuclear. Besides, rigorous environmental legislation should go along with the utilization of renewable energy. Further, the EAC countries should develop cutting-edge initiatives that can slow down the consumption of fossil fuels in cities and cut CO<sub>2</sub> emissions and their equivalent during the protracted process of urbanization. Therefore, it is important to implement clean energy cooking and efficient transportation systems in urban areas to reduce CO<sub>2</sub> emissions. Mass Rapid Transit, such as the use of electric buses and trains, can also help urban areas become more environmentally sustainable in the next decades. However, without a sound institution, it is impossible to maintain environmental quality, since governance has the potential to decrease CO<sub>2</sub> emissions. It is therefore for the EAC countries to improve the quality of their governance and build strong institutions that work.

## References

- EAC. (2022). Quick Facts about EAC. In *The East African Community*. <https://www.eac.int/eac-quick-facts>
- Espoir, D. K., Mudiangombe Mudiangombe, B., Bannor, F., Sunge, R., & Tshitaka, J. L. M. (2022). CO<sub>2</sub> emissions and economic growth: Assessing the heterogeneous effects across climate regimes in Africa. *Science of the Total Environment*, 804, 150089. <https://doi.org/10.1016/j.scitotenv.2021.150089>
- Grossman, G. M., & Krueger, A. B. (1991). *Environmental impacts of a North American free trade agreement*. 3914.
- IPCC. (2019). Climate Change and Land: an IPCC special report. *Climate Change and Land: An IPCC Special Report on Climate Change, Desertification, Land Degradation, Sustainable Land Management, Food Security, and Greenhouse Gas Fluxes in Terrestrial Ecosystems*, 1–864. <https://www.ipcc.ch/srccl/>
- Kimaro, D., & Mogaka, H. (2020). *Climate Change Mitigation and Adaptation in ECA / SADC / COMESA region : Opportunities and Challenges Climate Change Mitigation and Adaptation in ECA / SADC / COMESA region : Opportunities and Challenges Didas N . Kimaro , Alfred N . Gichu , Hezron Mogaka. December.*
- Liddle, B. (2015). What are the carbon emissions elasticities for income and population? Bridging STIRPAT and EKC via robust heterogeneous panel estimates. *Global Environmental Change*, 31, 62–73. <https://doi.org/10.1016/j.gloenvcha.2014.10.016>
- Niang, I., Ruppel, O. C., Abdrabo, M. A., Essel, A., Lennard, C., Padgham, J., & Urquhart, P. (2015). Africa. *Climate Change 2014: Impacts, Adaptation and Vulnerability: Part B: Regional Aspects: Working Group II Contribution to the Fifth Assessment Report of the Intergovernmental Panel on Climate Change*, 1199–1266. <https://doi.org/10.1017/CBO9781107415386.002>
- Pasara, M. T. (2019). *The welfare effects of economic integration in the Tripartite Free Trade Area MT Pasara orcid . org 0000-0003-4298-9585. April.*
- Rounce, D. R., Hock, R., & Shean, D. E. (2020). Glacier Mass Change in High Mountain Asia Through 2100 Using the Open-Source Python Glacier Evolution Model (PyGEM). *Frontiers in Earth Science*, 7. <https://doi.org/10.3389/feart.2019.00331>.



## Solar Photovoltaic End of Life Disposal Policy Assessment for the Kingdom of Saudi Arabia

Amjad Ali, Interdisciplinary Research Center in Renewable Energy and Power Systems, King Fahd University of Petroleum & Minerals, Dhahran (31261), Saudi Arabia, +966531082131, [amjad.ali@kfupm.edu.sa](mailto:amjad.ali@kfupm.edu.sa)

Fahad A. Alsulaiman, Interdisciplinary Research Center in Renewable Energy and Power Systems, King Fahd University of Petroleum & Minerals, Dhahran (31261), Saudi Arabia, +966138607311, [fahadas@kfupm.edu.sa](mailto:fahadas@kfupm.edu.sa)

Kashif Irshad, Interdisciplinary Research Center in Renewable Energy and Power Systems, King Fahd University of Petroleum & Minerals, Dhahran (31261), Saudi Arabia, +966547854711, [kashif.irshad@kfupm.edu.sa](mailto:kashif.irshad@kfupm.edu.sa)

Md Shafiullah, Interdisciplinary Research Center in Renewable Energy and Power Systems, King Fahd University of Petroleum & Minerals, Dhahran (31261), Saudi Arabia, +966506851062, [shafiullah@kfupm.edu.sa](mailto:shafiullah@kfupm.edu.sa)

Sheraz Alam Malik, College of Business, Al-Faisal University, Riyadh (11533), Saudi Arabia, +966533845384, [smalik@alfaisal.edu](mailto:smalik@alfaisal.edu)

Muhammad Zeeshan Malik, School of Electronics and Information Engineering, Taizhou University, Taizhou (318000), Zhejiang, China, +8613115256515, [malik4one@yahoo.com](mailto:malik4one@yahoo.com)

Md. Hasan Zahir, Interdisciplinary Research Center in Renewable Energy and Power Systems, King Fahd University of Petroleum & Minerals, Dhahran (31261), Saudi Arabia, +966542856377, [hzahir@kfupm.edu.sa](mailto:hzahir@kfupm.edu.sa)

### Overview

Kingdom of Saudi Arabia (KSA) recognizes the importance of a diversified energy mix with the penetration of renewable energy to its long-term economic prosperity. On January 9, 2019, Renewable Energy Project Development Office (REPDO) Saudi Arabia has revised the targets of its Vision 2030 to deploy approximately 58.7 GW of RE projects with a maximum of 40 GW of solar PV. In order to successfully implement the KSA vision 2030 RE targets and attain its benefits, formulation of solar PV end-of-life disposal/recycling policy instruments in the combination of economic optimization and technology localization (TL) factors must be taken into account to implement KSA vision 2030 in its true spirit.

After the successful implementation of KSA "Vision 2030" especially solar PV 40 GW targets, the most important issue will be their disposal at the end of life. The forthcoming challenge for the Kingdom of Saudi Arabia is the disposal of installed solar PV panels. It will detonate with its full force in one to two decades and ruin the environment because a huge amount (approximately 2.92 million tons) of wastage will be produced. Silicon-based photovoltaic cells contain a certain amount of toxic substances, which will create widespread toxic chemical pollution that would become a big environmental and health issue for the Kingdom of Saudi Arabia.

### Methods

A review of existing data practices in other relevant administrations and if possible, the identification of good practices adapted to the specific roles and needs.

Segregate available data, map and review in-house available sources

Developing main criteria/indications of quality of data and explore common practices



Identify references and sources of information, purpose and set timeline.

Listing and studying the main relationships on which relies to obtain the data from, identify nature of links and ways to improve data access with key partners

### Results

KSA solar PV Wastage
<b>Kingdom of Saudi Arabia Vision 2030 Target 40 GW of Solar PV</b>
<b>1 GW = 1,000,000,000 W</b>
<b>Average weight of 280W PV Panel is 18.6 Kg</b>

GW	W	Number of Modules	Weight in Kg	Weight in Tons
1	1,000,000,000	3,571,428.57	66,428,571.43	73,224.94
40	40,000,000,000	142,857,142.86	2,657,142,857.14	2,928,997.79

KSA Waste Management Law

Article No	Description
11	waste producers must reduce the waste, reuse products, and store it in the designated areas to conserve natural resources and materials.
14	It confines the extended responsibility of importers or local manufacturers for their products to ensure economic sustainability in the waste managing sectors and to enforce the idea of the circular economy. The concerned procedures and rules will be determined in the executive regulations for this law.
16 and 18	Advised the different roles and responsibilities of service providers related to waste management. For example, <ul style="list-style-type: none"> <li>Disposal service providers shall follow the national waste management center (NWMC) disposal methods.</li> <li>Transporters for hazardous waste shall adhere to NWMC standards by placing warning labels, using appropriate transportation, and guaranteeing the presence of documentation during the transportation of hazardous waste.</li> </ul>
19	It prohibits the import of any hazardous waste in the Kingdom of Saudi Arabia without authorization. It also forbids the import of recycled and used products, in addition, recycle waste, devices, and equipment.

**Conclusions**

Keeping in view of the development in the SPV installed generation capacity in the Kingdom of Saudi Arabia, it is obvious to formulate the proper and separate strategy for SPV modules end of life recycling and recovery. This study investigated the inevitability of SPV recycling by analysing the KSA's current "Waste Management Law" and it has been observed that there are not adequate details and information to handle SPV EoL problems. Therefore, we suggest and recommend that:

- To manage the upcoming waste management challenges, separate solar PV modules end of life disposal policy formulation is a need of time.
- Solar PV recycling shall be made mandatory by making manufacturers accountable for recovering materials from SPV modules at the end of life.
- In addition, the government shall formulate and adopt hard-liner policies/procedures and administer those to force the SPV materials manufacturers to consider the pros and cons of their products on the environment.
- Furthermore, it is also indispensable to put the responsibility on solar PV manufacturers to act dutifully and to outspread their responsibilities not only in SPV manufacturing but also all over the energy industry, to be responsible for the reuse or disposal of their products.

In summary, the management of solar PV modules EoL and other hazardous waste is mandatory.

**Abstract**

Solar photovoltaic (SPV) modules "End-of-life" (EoL) will become a global source of hazardous waste. Considering an average SPV module life of 25 years. By 2030 the global solar SPV waste is estimated to reach between 4%-14% of total generation capacity and is projected to increase to around 60 million tons by 2050. The Kingdom of Saudi Arabia (KSA) has also promulgated its VISION-2030 with the target of a 50% renewable energy electricity generation mix with more focus on solar PV (40 GW) for its total power generation system by 2030. It is anticipated that approximately 2.92 million tons of SPV wastage will be produced and EoL disposal will also become a crucial environmental issue in the next decades in KSA. Therefore, it is vital to carefully investigate the disposal and recycling of SPV modules EoL issues and challenges. In this paper, we investigated the Kingdom of Saudi Arabia's "Waste Management Law". It has been observed that there are not enough indications to handle SPV end-of-life problems in existing law. Therefore, it is indispensable to review KSA's existing Waste Management Law for improvements regarding the recycling of solar PV modules at end of life and the environmental performance of the PV industry with respect to recycling its products.



## ***HYDROGEN ECONOMY DEVELOPMENT IN SOUTH KOREA: LESSONS TO LEARN***

Jinsok Sung, Hankuk University of Foreign Studies, +82-10-3382-8515, jinsok.sung@hufs.ac.kr  
Zlata Sergeeva, King Abdullah Petroleum Studies and Research Center (KAPSARC),  
+966-56-704-1645, zlata.sergeeva@kapsarc.org

### **Overview**

This research is devoted to the analysis of the experience of South Korea in the establishment of the “hydrogen economy” – an economic and industrial structure using hydrogen as the main source of energy supply. Since the early 2000s, the country aimed at introducing hydrogen into different sectors of its economy. However, this process was not smooth. In the paper, we explain, why Korea’s first “Master Plan for Realization of Environment-Friendly Hydrogen Economy” unveiled in 2005, failed to achieve its targets. We describe the evolution of the motivation of the key Korean stakeholders to introduce hydrogen over time (from attempts to avoid risks of the “peak oil” and energy diversification in the early 2000s to managing emissions in the 2020s). We also show what main lessons the country learned along the road, and how it builds upon them now.

The Paris Agreement of 2015 gave a new impetus to South Korea’s hydrogen plans, which have been well covered in several key documents over the last few years. However, achieving a hydrogen-based energy system, which is called a “hydrogen economy”, is in the very early stage of development and faces a lot of technological, infrastructural, and economic challenges.

South Korea has limited possibilities for producing clean and low-carbon hydrogen domestically. Therefore, historically being a country heavily dependent on energy imports, even after the introduction of hydrogen in its energy system, South Korea is set to continue being a large-scale importer of energy. In this context, the paper argues that South Korea should continuously seek international cooperation to secure a stable supply of carbon-free hydrogen and solve technical challenges along the whole hydrogen value chain. Through international cooperation, South Korea will not only need to seek hydrogen supply but also end-user markets for H<sub>2</sub> vehicles and fuel-cell products. Strengthening the partnership between South Korea and traditional energy exporters like the Kingdom of Saudi Arabia will provide vast opportunities to both countries in this fledgling but fast-developing new market.

At the same time, South Korea is anticipated to become one of the key players in the formation of the hydrogen market with strong government support and active initiatives from the private sector. The detailed analysis of the country’s hydrogen strategies and the current status of development of the hydrogen economy provide a meaningful understanding of the present and future of the hydrogen industry in the country and lessons to learn for the other countries planning to bet on hydrogen.

### **Methods**

This research uses a case study method to analyze the role of hydrogen in the economic, environmental, and strategic goals of South Korea’s energy sector. We analyse the country’s aims and strategies regarding hydrogen enshrined in several key documents over the last few years, as well as the experience of its industrial companies.

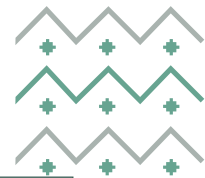
The experience of South Korea is important for both energy importing countries that are undergoing the process of the energy transition, and energy exporting countries that need to understand the strategies of their customers attempting to diversify their energy balances.

### **Results**

The research results show that from its unsuccessful experience the country carried out 2 main lessons. First, to achieve long-term nation-scale targets, all the plans and support must be carried out simultaneously and continuously for decades at all levels of regulation (both nationwide and local). Second, hydrogen should make economic sense and be price-competitive so that it could expand its presence in the market without long-term government support.







We also show that international cooperation is key to achieve the targets set by the South Korean government – and traditional exporters of energy to South Korea like Saudi Arabia are likely to occupy the emerging hydrogen niche.

## Conclusions

The paper presents lessons to learn from South Korea’s experience to introduce hydrogen economy. It also argues that South Korea should continuously seek international cooperation to secure a stable supply of carbon-free hydrogen and solve technical challenges along the whole hydrogen value chain. Through international cooperation, South Korea will not only need to seek hydrogen supply but also end-user markets for H<sub>2</sub> vehicles and fuel-cell products. Strengthening the partnership between South Korea and traditional energy exporters like the Kingdom of Saudi Arabia will provide vast opportunities to both countries in this fledgling but fast-developing new market.

## References

Government of South Korea. 2018. “혁신성장 전략투자 방향” [“Innovative Platform”]. Government of South Korea, August 13, 2018. [https://www.moef.go.kr/com/synap/synapView.do;jsessionid=Ah8OwYFipjDplyGBNeDbFhPF.node20?atchFileId=ATCH\\_00000000008766&fileSn=2](https://www.moef.go.kr/com/synap/synapView.do;jsessionid=Ah8OwYFipjDplyGBNeDbFhPF.node20?atchFileId=ATCH_00000000008766&fileSn=2).

International Energy Agency. 2020. “Korea 2020. Energy Policy Review”. Accessed June 21, 2022. 204 p. [https://iea.blob.core.windows.net/assets/90602336-71d1-4ea9-8d4f-efeeb24471f6/Korea\\_2020\\_Energy\\_Policy\\_Review.pdf](https://iea.blob.core.windows.net/assets/90602336-71d1-4ea9-8d4f-efeeb24471f6/Korea_2020_Energy_Policy_Review.pdf).

K-New Deal. n.d. Accessed June 21, 2022. <https://www.knewdeal.go.kr/>.

Korea Policy Briefing. 2021. “수소 클러스터 구축사업, 예비타당성조사 대상사업으로 선정” [“Hydrogen cluster construction project, selected as a project for preliminary feasibility study”]. Korea Policy Briefing. August 24, 2021. <https://www.korea.kr/news/pressReleaseView.do?newsId=156467583>.

McQue, Katie. 2021. “Saudi Aramco sees hydrogen market gaining momentum after 2030”. S&P Platts, February 22, 2021. <https://www.spglobal.com/platts/en/market-insights/latest-news/electric-power/022221-saudi-aramco-sees-hydrogen-market-gaining-momentum-after-2030>.

Ministry of Environment. 2015. “수소차 보급 및 시장 활성화 계획” [“Action Plan for the Development of H2 Mobility”]. Accessed June 21, 2022. [http://www.me.go.kr/home/web/policy\\_data/read.do?pagerOffset=10&maxPageItems=10&maxIndexPages=10&searchKey=&searchValue=&menuId=10262&orgCd=&condition.code=A3&seq=6667](http://www.me.go.kr/home/web/policy_data/read.do?pagerOffset=10&maxPageItems=10&maxIndexPages=10&searchKey=&searchValue=&menuId=10262&orgCd=&condition.code=A3&seq=6667).

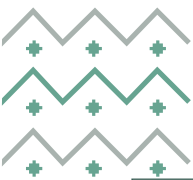
Ministry of Environment. 2021. “5년 내 전기차 113만대·수소차 20만대 보급한다” [“To supply 1.13 million electric vehicles and 200,000 hydrogen vehicles within 5 years”]. Korea Policy Briefing, July 22, 2021. <https://www.korea.kr/news/policyNewsView.do?newsId=148874996>.

Ministry of Foreign Affairs. 2021. “2050 탄소중립 시나리오안” [“Scenarios for Carbon Neutrality 2050”]. Accessed June 21, 2021. [https://www.mofa.go.kr/www/brd/m\\_4080/down.do?brd\\_id=235&seq=371662&data\\_tp=A&file\\_seq=4](https://www.mofa.go.kr/www/brd/m_4080/down.do?brd_id=235&seq=371662&data_tp=A&file_seq=4).

Ministry of Trade, Industry and Energy. 2017. “한-사우디 비전 2030 민관협력 플랫폼 출범” [“Launch of the Korea-Saudi Vision 2030 Public-Private Cooperation Platform”]. MOTIE, October 26, 2017. [https://motie.go.kr/motie/ne/presse/press2/bbs/bbsView.do?bbs\\_seq\\_n=159753&bbs\\_cd\\_n=81](https://motie.go.kr/motie/ne/presse/press2/bbs/bbsView.do?bbs_seq_n=159753&bbs_cd_n=81).

Ministry of Trade, Industry and Energy. 2022. “(참고자료)대통령 사우디 방문 계기에 「한-사우디 스마트 혁신성장 포럼(1.18, 리야드)」 개최” [“Press release. Held the Korea-Saudi Smart Innovation and Growth Forum (Jan. 18, Riyadh) on the occasion of the President’s visit to Saudi Arabia”]. MOTIE, January 19, 2022. [http://www.motie.go.kr/motie/ne/presse/press2/bbs/bbsView.do?bbs\\_cd\\_n=81&bbs\\_seq\\_n=165176](http://www.motie.go.kr/motie/ne/presse/press2/bbs/bbsView.do?bbs_cd_n=81&bbs_seq_n=165176).





**IMPACT OF REPLACEMENT COAL AND FOSSIL ENERGY BY NUCLEAR ENERGY ON GLOBAL GREENHOUSE GASES EMISSION**

Mohamed Abdelaziz, Egyptian Atomic Energy Authority, +201004613659, mabdelazizm36@yahoo.com  
 Hesham Elkhatib, Egyptian Atomic Energy Authority, +201067453771, heskhatib1966@yahoo.com  
 Abdelfatah Abdelmaksoud, Egyptian Atomic Energy Authority, +201010305262, abdelatah.ali\_eg@yahoo.com  
 Mohamed Esawy, Egyptian Atomic Energy Authority, +201010796661, eng\_moheesawy@yahoo.com

**Overview**

Climate change has become one of the important matters that worry humanity worldwide, until local seminars and international conferences have been held for it at the highest levels, such as the level of heads of state. What is worrying about climate change is the increase in the average global temperature until it soon reaches the age of mankind, which has reached 1.5 degrees Celsius until the year 2033 and 2 degrees Celsius until the year 2059, as an inevitable result of the increase in carbon emissions resulting from electricity generation, industry and vehicle exhaust, which were estimated at about 1000 gigabytes of tons until the year 2060, in which the production of electrical energy contributes by more than 50%. On the other hand, the unjust encroachment on forests, this is the lung of the world. Since electric power generation is responsible for more than half of the global emissions of carbon gases, this research aims to study the carbon emissions resulting from electric power generation with the scenarios of Unfinished Symphony, Jazz and Hard Rock, and trying to reduce the carbon emissions resulting from electric power generation by replacing electricity generation with nuclear energy as an alternative to coal all types, as well as petroleum (fossil fuels), with the stability of the use of natural gas and new and renewable energies according to previous scenarios until the year 2060. The result was, according to the Unfinished Symphony scenario, emissions were about (591.9) Giga tons. In contrast, when using nuclear energy as an alternative, the contribution of electricity production by 65% cancels out the improvement in the amount of carbon emissions by 75.1%, with a carbon dioxide productivity of 146.8 Giga tons. According to the Jazz scenario, emissions were about (632.1) Giga tons. In contrast, when using nuclear energy as an alternative, the contribution of electricity production is 65%, which cancels out the improvement in the amount of carbon emissions by 75.2%, with a carbon dioxide productivity of 156.8 Giga tons. According to the Hard Rock scenario, emissions were about (643.3) Giga tons. In contrast, when using nuclear energy as an alternative, the contribution of electricity production is 65%, which cancels out the improvement in the amount of carbon emissions by 74.87%, with a production of carbon dioxide that amounted to 161.6 Giga tons.

**Methods**

Our estimation model is based on contribution of each energy generation source type to generate CO<sub>2</sub>. This is shown in table (1). The energy production in Fig. (1) illustrates each energy source contribution in Unfinished Symphony scenario. The oil contribution is the highest one while the other contribution is the lowest which comes from renewable energy sources. This contribution is the same in all studied scenario but with various values in each scenario. The contribution of oil begins year 2021 with 6.105E+06 GWH and expected to be 7.416E+06 GWH with percentage 21.47% more in 2060. The energy production in Fig. (2), illustrates each energy source contribution in Modern Jazz scenario. The oil contribution still represent highest one. The contribution of oil in this scenario begins year 2021 with 6.124E+06 GWH and expected to reach 8.389E+06 GWH with percentage 27% more in 2060. While analyzing the last (HR) scenario in Fig. (3), it is found out that oil contribution in energy production is expected to be 8.867E+06 GWH with percentage increase about 30.8%. The global emission related to the present scenarios and their present contributions are shown in figures (7), (8) and (9).

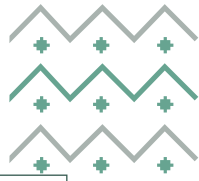
The emitted CO<sub>2</sub> in case of Unfinished Symphony scenario for coal source is 6.867 Giga tonnes and from oil source is 5.377 Giga tonnes in year 2060, while the total accumulated CO<sub>2</sub> emission is 592 Giga tonnes. Regarding the other scenarios, it is illustrated that it is more in case of Modern Jazz with total accumulated predicted value 632 Giga tonnes and 643 Giga tonnes in case of Hard Rock in year 2060.

**Results**

The emission factor of CO<sub>2</sub> for each scenario is predicted according to the following table:

Factor KgCO <sub>2</sub> /kWh	Unfinished Symphony	Modern Jazz	Hard Rock
Previous model	21.55	20.35	19.59
Proposed model	5.344	5.046	4.919





It is noticed, when we compare previous model and developed proposed model in the end of year 2060 that the emission factor is 21.55 kgCO<sub>2</sub>/kWh in present unfinished Symphony and reduced to 5.344 kgCO<sub>2</sub>/kWh. In case of Modern Jazz it reduced from 20.35 in previous model to 5.046 in developed model and finally from 19.59 to 4.919 in Hard Rock scenario. Enhancements are relatively illustrated in table and emission factors that indicates great difference in values towards less pollution which encourage countries to convert most dirty energy generations to nuclear energy generation in future.

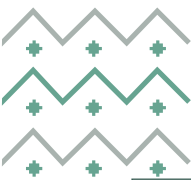
### Conclusions

Due to global electricity demand increases gradually and annually about 3% towards 2060, the nuclear, natural gas and renewable energies production is proposed to meet a majority of the increase in energy demand instead of coal and crude oil. The climate change represents main challenge and considered the main incentive factor that leads the world to find out effective solution. Three standard scenarios are applied in our model; Unfinished Symphony, Modern Jazz and Hard rock respectively. Using nuclear power technology source is our choice and proposal to generate energy instead of coal and fossil fuel to reduce CO<sub>2</sub> emissions. This proposed model expects reducing CO<sub>2</sub> emission in 2060 for Unfinished Symphony scheme from 592 to 147 Giga tonnes. For Modern Jazz it is expected to reduce CO<sub>2</sub> emission from 632.1 to 156.8 Giga tonnes finally in Hard rock scheme it is reduced from 643.3 to 161.6 Giga tonnes. So it is concluded that replacing coals and fossil fuel sources with nuclear energy technology is a good solution to reduce global CO<sub>2</sub> emission in the future 2060, which is found out very efficient and effective towards climate changes enhancement, so employing more nuclear power reactors with intensive safe technology will encourage countries converging to this technology and satisfies global world energy demands and also combats global warming.

### References

- [1] IAEA, nuclear power and the Paris agreement (2016).
- [2] Long-term optimization of Egypt's power sector: policy implications Mondal et al. / energy 166 (2019)
- [3] <http://www.world-nuclear.org/focus/climate-change-and-nuclear-energy.aspx>
- [4] <http://www.nirs.org/climate/climate.htm>
- [5] [http://ec.europa.eu/research/energy/euratom/index\\_en.cfm?pg=fission&section=generatin](http://ec.europa.eu/research/energy/euratom/index_en.cfm?pg=fission&section=generatin)
- [6] <http://www.energy.gov/ne/office-nuclear-energy>
- [7] <https://www.euronuclear.org/e-news/e-news-20/gra.htm>
- [8] [https://en.wikipedia.org/wiki/generation\\_iv\\_reactor](https://en.wikipedia.org/wiki/generation_iv_reactor).
- [9] Asian insights Sparx 2030 energy mix, DBS group research. Equity 5 Jul 2018.
- [10] <http://theamericanenergynews.com>
- [11] World energy council registered in England and Wales no. 4184478, published by the world energy council 2016
- [12] Endresen, et al., emission from international sea transportation and environmental impact, journal Geophys. res. atmos., 108 (2003), d17
- [13] Imo Mepc 59/4, prevention of air pollution from ships – second Imo GHG study 2009, London, 2009
- [14] Mersin, k., et al.: review of CO<sub>2</sub> emission and reducing methods in maritime thermal science: year 2019, vol. 23, suppl. 6, pp. s2073-s2079
- [15] Christopher Jones et al.: toward a zero-carbon energy policy in Europe: defining a viable solution. April 2010, vol. 23, issue 3, 2010 Elsevier Inc.
- [16] Energy statistics pocketbook United Nations New York, 2022, Department of Economic and Social Affairs Statistics Division, Statistics Papers Series E No. 5
- [17] Jeremias M. Balogh et al.: Determinants of CO<sub>2</sub> emission: a global evidence, International Journal of Energy Economics and Policy, 2017, 7(5), 217-226.
- [18] Climate change and nuclear power 2018, International Atomic Energy Agency, Vienna, 2018.





## ***NON-LINEAR EFFECTS OF ENVIRONMENTAL POLICIES ON LOW-CARBON TECHNICAL CHANGE: THE CASE OF THE FRENCH BUILDINGS SECTOR***

Valentin Laprie *a,b,c*

*a* EconomiX, Université Paris Nanterre (UMR 7235), Nanterre, France

*b* Climate Economics Chair, Paris, France

*c* Centre Scientifique et Technique du Bâtiment, Champs-sur-Marne, France

valentin.laprie@chaireeconomieduclimat.org

+33 6 85 85 49 25

### **Overview**

While quite overlooked in the induced innovation literature, low-carbon technical change for the building sector presents interesting features. First, the sector is a major contributor to current levels of pollution. In 2019, 21% of the world's final energy consumption and 6% of the world's CO<sub>2</sub> emissions were attributable to the residential sector. Thus, low-carbon innovation for buildings represents an opportunity to decrease the cost of future emissions abatement. Second, as specified by Urge-Vorsatz et al. (2016), low-carbon solutions for buildings generate overlapping benefits above economic and environmental issues. Among other co-benefits we can cite improvement of well-being and sanitary levels of dwellings, increase in "green" employment and decrease of employment in fossil energy sector, increase in disposable income for households, increase in energy security and sovereignty. Thus, low-carbon technical change for buildings provides environmental, economical, social, sanitary and geopolitical benefits. However, it is well established that technical change is not directed toward clean technologies under *natural* market conditions. The absence of price for polluting activities along with existing positive knowledge spillovers do not bring enough incentives for firms to innovate in low-carbon technologies. Moreover, Acemoglu et al. (2012) highlighted the existence of path dependencies toward *dirty* technologies when a country historically invested in that sector and build a stock of knowledge making future *dirty* innovations more profitable. In this context the aim of the present paper is to assess the potential of several environmental public policies to redirect technical change toward low-carbon technologies in the building sector.

### **Methods**

We use a count model for patents aiming to reduce CO<sub>2</sub> emissions in buildings filed at the French office or through a EP or PCT procedure designating France from 1970 to 2019. France is chosen for its diversity of environmental policies among which carbon tax, energy standards for buildings, energy efficiency policies and R&D public support. The major contribution of the paper is the use of a Distributed Lag non-Linear Model (DLNM) to relax simultaneously two kind of implicit assumptions commonly made when estimating relationship between environmental policies and low-carbon technical change. On the one hand, we allow effects from policies to be non-linearly distributed across time rather than occurring punctually with a unique delay. On the other hand, we allow effects from policies to be non-linearly distributed across the level of the policy. For instance, we allow an increase of the carbon tax to have different effects on patents in  $t + 1$ ,  $t + 2$ , ...,  $t + \ell$ ... and to have different effects on patents depending on the level from where the increase starts.

### **Results**

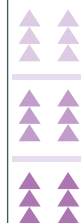
The first important result is that while higher household energy expenditures in buildings induce more low-carbon patents, there is a concave relationship implying that too high levels of expenditures does not induce more *clean* innovations. We explain it by the lower level of disposable income and demand for low-carbon technologies associated with highest levels of energy expenditures for buildings. Second, it appears that French energy standards for buildings are the main driver for *clean* innovations with 110% more patents induced. However, standards have to be flexible and more and more stringent to generate incentives to innovate. Third, energy efficiency policies are also an important driver, especially subsidies and zero-interest loan for energy efficient investments. Fourth, we show that direct public support to R&D in energy efficiency is of too low levels to induce significantly low-carbon innovations. Also, we find an interesting negative association between the level of public support to nuclear R&D and the level of low-carbon technical change for buildings either explained by R&D inputs substitutions or by the decreasing pressure to find low-carbon solutions for end-users as the electricity production become "cleaner".

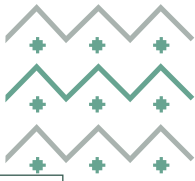
### **Conclusions**

The results are of primary importance for decision makers. If their objective is to promote clean innovation in order to contract future CO<sub>2</sub> emissions, the price instrument (proxied by household energy expenditure in our study) must be used with caution. Too high a price of CO<sub>2</sub> could have effects opposite to those expected by reducing the purchasing power of households and the incentives to innovate coming from the market. Instead, policymakers should focus on outcome-oriented rather than means-oriented energy standards and make them broader and stricter over time. Finally, energy efficiency policies such as subsidies or interest-free loans are all instruments for increasing demand and incentives to innovate towards low-carbon technologies.

### **References**

- Acemoglu, Daron, Philippe Aghion, Leonardo Bursztyn, and David Hemous, "The Environment and Directed Technical Change," *American Economic Review*, February 2012, 102 (1), 131–66.
- Urge-Vorsatz, Diana, Agnes Kelemen, Sergio Tirado-Herrero, Stefan Thomas, Johannes Thema, Nora Mzavanadze, Dorothea Hauptstock, Felix Suerkemper, Jens Teubler, Mukesh Gupta et al., "Measuring multiple impacts of low-carbon energy options in a green economy context," *Applied Energy*, 2016, 179, 1409–1426.





## Longship – a fully financed North Sea CCS-project

Torstein Indrebo, Norway

Vice Chair Bureau, Group of Experts on Gas, UNECE Committee on Sustainable Energy,  
representing the Norwegian Ministry of Petroleum and Energy.

Phone: +47 48197155

Email: torindr@broadpark.no

### Overview

Norway has committed to ambitious reduction of its carbon emissions along with other countries in order to tackle climate change.

The paper will present the Longship carbon capture and storage (CCS) project launched and fully financed by the Norwegian government in 2020. The government has formed partnership with key industrial companies based in Norway to reduce emissions, notably with Norcem (HeidelbergCement Group) and the waste-to-energy plan Fortum Oslo Varme.

The Longship-project includes carbon capture and liquifaction at site, transportation of carbon by ship to terminal, where it is piped offshore, and injected into a storage 2600 meter below the seabed.

Total cost is estimated to about 2,5 billion USD of which the government share is about 1,7 billion USD.

A new venture named Northern Lights JV is formed by Equinor, TotalEnergies and Shell to operate the Longship-project and to commercialise other CCS-projects in Europe based on the established Longship value chain.

The project, to be in operation in 2024, will support the Paris-agreement goals by reducing emissions initially in Norway and later in wider Europe. Initial CO<sub>2</sub> storage capacity is 1,5 million tonnes annually while plans are in place for storing up to 5 million tonnes of CO<sub>2</sub> per year.

### Methods

The paper is based on information from the government of Norway and the partners in Northern Lights. Information has been collected from several industrial companies in Europe with expressed interest to use this technology and the services of Northern Lights JV to reduce emissions of climate gases.

### Results

The project has already attracted extensive interest and has illustrated that CCS is an important technology for hard-abating CO<sub>2</sub>-emitting industries. It can be commercialised when scaled up to large volumes to be captured and stored. It has demonstrated that the infrastructure and competence of the oil and gas industry is a key element in reducing the global CO<sub>2</sub> emissions.

The Longship CCS-project will also enable production of blue hydrogen by use of natural gas in combination with carbon capture and storage. Hydrogen is a key element in decarbonising hard to abate industrial sectors in Europe.

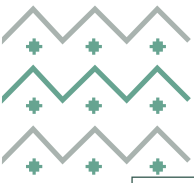
The Northern Light JV has already signed many letters of intent industrial companies for use of the Norwegian offshore carbon storage, and many more are in dialogue about the same.

### Conclusions

The project has documented that carbon can be captured and safely stored below the seabed. Norwegian industry has many years of storing carbon from the oil and gas fields Sleipner and Snøhvit.







Storage of CO<sub>2</sub> offshore rather than onshore takes away public concerns and enables transportation of the CO<sub>2</sub> to be stored from industries along coastal Europe to the North Sea either by ship or by pipeline.

The Longship project demonstrates that CCS is an important technology for industries with emissions hard to abate. The CCS-technology can be commercialised when scaled up to large volumes to be captured and stored.

The project has demonstrated that the infrastructure and competence of the oil and gas sector are important for realisation of new technologies that are required to meet the Paris-agreement.

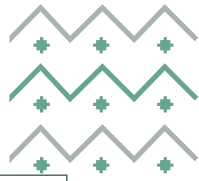
The CCS-technology can be used to reduce emissions from natural gas, coal and biogas (negative emissions) used in power generation and industrial activities. It can furthermore be used to produce blue hydrogen.

It is the first cross-border full scale CCS-project in the world.

### **References**

Norwegian Parliamentary Report no 33 (2019-2020).





## [TECHNO-ECONOMIC ANALYSIS: CHARGING AIRPORT'S ELECTRICAL BAGGAGE TRACTORS WITH HYDROGEN FUEL CELL]

[Sadeq Ahmed Alfatesh, King Saud University, +966 53 488 1106, Sadeq.sq@gmail.com]  
 [Musab Fahad Alsalamah, King Saud University, +966 55 358 8861, Musab1238@outlook.sa]  
 [Dr. Mansour S. Alhoshan, King Saud University, +966 55 322 5885, Mhoshan@ksu.edu.sa]  
 [Dr. Abdulaziz Bentalib, King Saud University, +966 55 288 1118, Abentalib@ksu.edu.sa]

### Overview

Fossil fuel is one of the most harmful environmental factors due to carbon dioxide emissions. The CO<sub>2</sub> emission causes global warming urges the world to look for renewable energy sources that are environmentally friendly and sustainable. Green hydrogen is one of the promising sources of clean energy. Many countries and companies have begun to invest in the green hydrogen economy. The Kingdom of Saudi Arabia targets to be the world's largest producer and exporter of green hydrogen to maintain its position as the world's largest energy source, as stated in the Green Saudi Initiative. All this interest in green hydrogen utilization will decrease costs and prompt investors to invest more in its research and development.

Saudi's General Authority of Civil Aviation (GACA) aims to reduce its carbon emissions in Saudi Airports to achieve zero neutrality by 2060 in line with Green Saudi Initiative [1]. Therefore, in this study, the economic feasibility of a project to charge 45 electrical baggage tractors in airports using green hydrogen will be accomplished with a project lifetime estimated to be 20 years. A diesel tractor emits 118 tons of carbon dioxide [2], and charging one electrical tractor from the power grid will indirectly emit 35.2 tons of carbon dioxide annually. Using green hydrogen with fuel cells is one of the most effective ways to produce electricity with zero carbon emissions. Table 1 compares current and proposed scenarios.

Table 1: Comparing the current scenario with the proposed scenario

	Scenarios		
	Current	Current	Proposed
<b>Power generator</b>	Fossil fuel	Power grid	Fuel cell
<b>Tractor engine</b>	Diesel	Electrical	Electrical
<b>Overall efficiency</b>	45%	45%	56%
<b>CO<sub>2</sub> emission per tractor</b>	118.0 tons CO <sub>2</sub> /year	35.0 tons CO <sub>2</sub> /year	0.00 tons CO <sub>2</sub> /year
<b>Initial cost</b>	Low	Medium	High
<b>Maintenance</b>	Frequently	Rarely	Rarely

### Methods

Polymer Electrolyte Membrane Fuel Cell (PEMFC) uses green hydrogen to react with oxygen to produce electricity and emit only water vapor. The tractors require 360.0 kW of power to be charged. Therefore, the PEMFC needs to be split into stacks of cells to avoid blockage in the cell due to the high current density required, the stack will be 10.0 kW connected in series and charging the batteries four times daily.

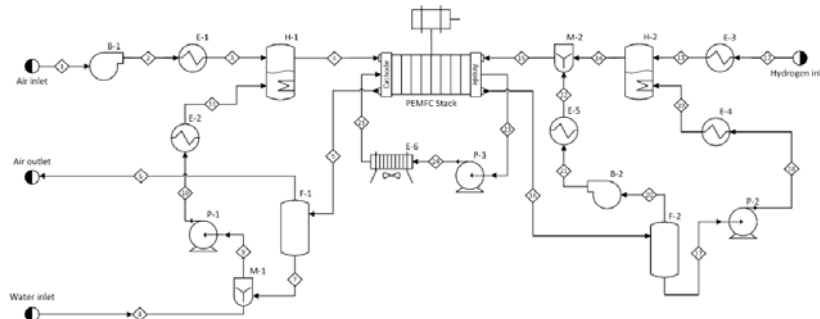
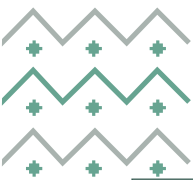


Figure 1: Flowsheet of Polymer Electrolyte Membrane Hydrogen Fuel Cell

Based on our PEMFC system design shown in Figure 1, with a power factor of 0.751, the rest is used to operate the system's equipment to make the station stand-alone. According to a cost analysis from National Renewable





Energy Laboratory, the system price is \$4,750.0 for each kW [3]. For the operating cost, the hydrogen price was set at \$2.77 per kilogram [4], with the hydrogen price decreasing at a rate of 3.5% annually to reach \$1.36 at the end of the project's life. The system will be maintained every five years and will cost 6.0% of the system cost. The project will achieve its profits by saving the cost of electricity and avoiding the carbon price tax by reducing carbon emissions. The global average electricity price is estimated at \$0.15 per kWh, increasing at a rate of %2.5 annually to reach \$0.24 by the end of the project [5]. The global carbon price average is estimated at \$35.14 per ton of CO<sub>2</sub>, increasing by 9.1% annually, to reach \$200.58 by the end of the project [6].

## Results

The study assumed the station would be constructed in 2023 to run in 2024 and continue operating until 2043. A system of 479.44 kW will be needed based on the net power output of the PEMFC. Therefore, the system cost will be \$2.277 million. The system's net power generated annually is 3,153.6 MWh using 289.54 tons per year of hydrogen. Establishing this project will cut 5,309 tons of carbon dioxide emissions annually if diesel tractors are used and 1,583 tons of carbon dioxide if the power grid charges electrical tractors. The project will start making profits in its 7th year and will reach the break-even point in 18 years, as shown in Figure 2.

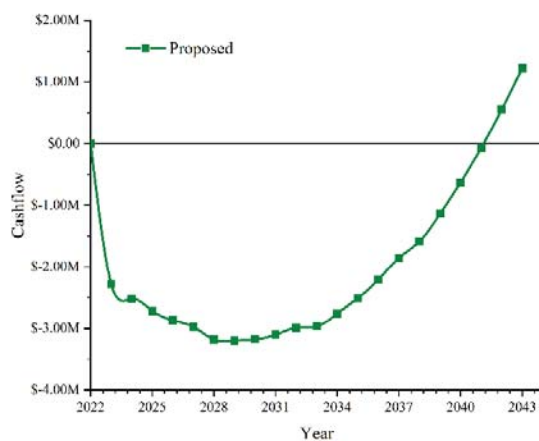


Figure 2: Cashflow of the system

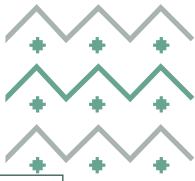
## Conclusions

Although the objective of the project is not for economic purposes, the project will make a profit in long term. Establishing this project contributes to achieving Saudi's goals of zero carbon emissions, strengthening the Green Saudi Initiative, and pushing the wheel of investment in the green hydrogen economy and clean energy. The target stated by the department of energy in the US is to make the PEMFC power factor reach 0.833 [7], which pushes the research and development to decrease the system's power loss, and our design is close to this target. Establishing this project will be equivalent to planting 73,000 middle-aged trees, which has a significant impact.

## References

- [1] "King Khalid International Airport Obtains Airport Carbon Accreditation from Airports Council International," *Saudi Press Agency*, Jan. 09, 2022. Accessed: Sep. 01, 2022. [Online]. Available: <https://www.spa.gov.sa/viewfullstory.php?lang=en&newsid=2319382>
- [2] J. Blanchard, "Fuel Cell Powered Airport GSE (Ground Support Equipment) Deployment," Golden, CO (United States), Mar. 2020. doi: 10.2172/1606013.
- [3] "Cost of Renewable Energy Spreadsheet Tool. Fuel Cells.," *National Renewable Energy Laboratory*, 2014. <https://www.nrel.gov/analysis/assets/docs/nrel-crest-fuel-cell.xlsx> (accessed Sep. 04, 2022).
- [4] H. Edwardes-Evans, "Green hydrogen costs 'can hit \$2/kg benchmark' by 2030: BNEF," *S&P Global Commodity Insights*, London, Mar. 30, 2020. Accessed: Sep. 05, 2022. [Online]. Available: <https://www.spglobal.com/commodityinsights/en/market-insights/latest-news/coal/033020-green-hydrogen-costs-can-hit-2kg-benchmark-by-2030-bnef>
- [5] "Short-Term Energy Outlook," Aug. 2022. Accessed: Sep. 03, 2022. [Online]. Available: <https://www.eia.gov/outlooks/steo/>
- [6] "EU Carbon Price Tracker," *Ember*. <https://ember-climate.org/data/data-tools/carbon-price-viewer/> (accessed Sep. 02, 2022).
- [7] Battelle, "Manufacturing Cost Analysis Of 10 kW And 25 kW Direct Hydrogen Polymer Electrolyte Membrane (PEM) Fuel Cell For Material Handling Applications," Ohio, Mar. 2021.





## QUEST FOR ENERGY DIVERSIFICATION IN MENA – OPPORTUNITIES AND CHALLENGES FOR HYDROGEN ECONOMY

Shahid Hasan, Fellow, KAPSARC, +966-11-2903020, [shahid.hasan@kapsarc.org](mailto:shahid.hasan@kapsarc.org)

Rami Shabaneh, Fellow, +966-11-2903143, KAPSARC, [rami.shabaneh@kapsarc.org](mailto:rami.shabaneh@kapsarc.org)

### Overview

Only a few years back, hydrogen energy was not an integral part of the energy sector transformation strategies introduced by a number of countries in the Gulf Cooperation Council (GCC) and Middle East and North Africa (MENA) regions. With hydrogen energy getting significant attention for its role in achieving the energy transition objectives, several countries are revisiting their energy sector strategies that previously guided the energy sector's development. Specific and tailored strategies are being designed as part of their evolving energy policy landscape to benefit from hydrogen energy's contributions to the local (and the global) energy transition. While Morocco, UAE, Egypt and Oman have unveiled the national hydrogen strategies/roadmaps among the MENA countries, Saudi Arabia has announced its target of producing 4 million tons of clean hydrogen by 2030.

Further, with attractive low-cost and low-carbon hydrogen potential, these countries aim to develop the local hydrogen industry for exporting green and blue hydrogen to other potential markets. The hydrogen export expected to provide opportunities for resource monetization in the energy transition and diversification of energy exports away from oil to compensate for shrinking oil exports during long-term decarbonization partly.

The Middle East (and the GCC countries in particular) have several competitive advantages that make it well placed to capitalize on the global shift towards clean hydrogen and enable it to meet the future energy demand domestically and internationally. However, to unlock the full potential of the hydrogen economy, GCC and MENA countries must address issues around hydrogen demand creation (including exports), private sector participation, hydrogen infrastructure, business risks, pricing, regulation of hydrogen activities, etc.

This paper first presents the emerging drivers behind countries' desire to embrace hydrogen as a new sunrise industry in the energy sector in the region, which collectively holds about 57% of the world's proven oil reserves and 41% of proven natural gas resources. It also examines the general contours of evolving energy policy and strategies in the selected countries in the MENA and how the current energy transition frameworks support hydrogen energy. Lastly, it also takes stock of developments on the regulatory front, mainly in the energy sector, and identifies areas requiring attention to kickstart the progress toward a hydrogen-based economy in the future.

### Methods

This paper uses qualitative research techniques involving collecting and analyzing non-numeric information, including hands-on peer-reviewed research relevant to the focus of this paper. Structured interviews with experts will also be conducted where necessary to arrive at holistic and clear findings. Further, numerical data will be collected and analyzed to support the analysis and conclusions.

### Results

The key takeaways are briefly presented below:

#### Sustainability objectives outlined in energy sector policies complement hydrogen development

Most countries in the region are revisiting their energy policies to include (or support) hydrogen energy. Morocco's long-term low-carbon emission strategy for 2050 proposes to increase the share of renewables in the electricity mix to 70% by 2040 and 80% by 2050 to support the development of green hydrogen to decarbonize industry and road freight. The UAE Energy Strategy 2050 (released in 2017) underpins sustainability in the production and use of energy. The strategy aims to reduce the carbon footprint of power generation by 70% by increasing the contribution of clean energy sources to 50% by 2050. Integrated Sustainable Energy Strategy (ISES) 2035 of Egypt is being





updated to include green and low-carbon hydrogen among the portfolio of sustainable energy resources. The energy sector in Saudi Arabia is guided by sustainability objectives set out in Vision 2030. Saudi Arabia is undergoing a significant transition to low-carbon energy generation and aims for 50% RE by 2030. While the hydrogen strategy is under preparation, several memorandum of understanding (MoUs) have been signed to promote hydrogen use in the transportation sector, including aviation in the country. Oman's hydrogen ambitions are also guided by Oman Vision 2040, which prioritizes developing policies and procedures to reduce carbon emissions, and encourages the utilization of renewable energy. Further, developments on hydrogen front are also influenced by the commitment to reach net-zero carbon emissions by 2050 (UAE and Oman) or 2060 (Saudi Arabia).

#### Drivers for embracing hydrogen are common across the region

As countries in the region possess significant hydrocarbon resources, their energy needs in the past have largely been met through oil and gas. In addition to hydrocarbon resources, the MENA region also has vast solar and wind potential. There is a growing desire to augment non-hydrocarbon resources, including hydrogen energy, for energy security, sustainability, and economic reasons. Hydrogen energy is also seen as an important enabler for (i) accelerating the energy transition towards a clean, secure, and environmentally sustainable energy system locally and (ii) facilitating the energy transition in other major world economies through the export of hydrogen (or hydrogen derivatives), and (iii) monetizing their resources and diversifying their revenues.

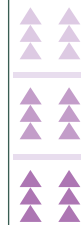
#### Common challenges

While the governments are acting proactively to position themselves as the leading producer and exporter of low-carbon (green and blue) hydrogen in the region, realizing their hydrogen ambitions also faces some challenges. These included:

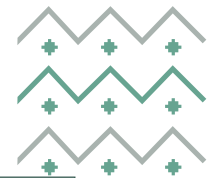
- The oil & gas and electricity sector have far matured legislative, institutional, and regulatory structures. However, for systematic and sustained implementation of the hydrogen agenda, countries must design regulations covering the entire hydrogen value chain.
- With few exceptions, most countries have relatively low renewable energy capacity. Meeting green hydrogen energy production targets will require a significant ramp-up in renewable energy capacities.
- Currently, transport, delivery and storage infrastructure for hydrogen energy does not exist. To effectively achieve the set hydrogen production targets, countries need to put in the matching infrastructure facilities.

#### **Conclusions**

There is no doubt the MENA region is endowed with the resources required to produce green and blue hydrogen. However, with the enabling policies and regulatory framework to drive clean hydrogen production, these efforts may see progress. The countries can leverage the mechanisms already in place to increase the share of gas and renewable energy and pass those through for hydrogen production. However, some markets in MENA are more developed than others, and our analysis will develop a policy heatmap to determine the policy gaps for each country in MENA.







## ***EVALUATING SPATIAL SPILLOVER EFFECTS OF RENEWABLE AND NON-RENEWABLE ENERGY ON ENVIRONMENTAL DEGRADATION***

Amjad Naveed, Aarhus University, Denmark [amjadn@btech.au.dk](mailto:amjadn@btech.au.dk)  
Nisar Ahmad, Sultan Qaboos University (SQU), Oman, [nisar@squ.edu.om](mailto:nisar@squ.edu.om)  
Reza Fathollahzadeh A. SQU, Oman, [rezafa@squ.edu.om](mailto:rezafa@squ.edu.om)

### **Overview**

This paper empirically evaluates the effect of renewable and non-renewable energy consumption on environmental degradation (CO<sub>2</sub> emission). A spillover effect may occur when emission occurs in one location and then travels to a location that is adjacent to it. Similarly, renewable and non-renewable energy consumption also have a spillover effect on neighbouring locations. In the theoretical literature, this phenomenon is known as spatial dependence and ignoring such dependence might produce biased results in empirical examination. Therefore, the current study applies spatial econometric techniques to determine the spillover effect of renewable and non-renewable energy on environment under the Environmental Kuznets Curve (EKC) framework. Using a global sample of 96 countries over the period 1990-2014, the results show that EKC hypothesis holds with the presence of a significant negative impact of renewable energy and a significant positive impact of non-renewable energy on CO<sub>2</sub> emissions. Additionally, the spillover (indirect) effect of renewable energy consumption on CO<sub>2</sub> emissions is found to be greater than the direct effect. However, non-renewable energy has a positive impact on CO<sub>2</sub> emissions with a lower level of spillover effect. From a policy perspective, it stresses that increasing renewable energy sources will not only benefit to that country but also have a spillover effect on its neighbouring country.

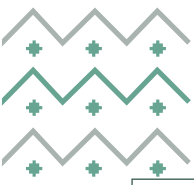
### **Methods**

Our empirical strategy starts from a simple econometric model by using EKC framework (Kuznets, 1955). Under EKC hypothesis, environmental degradation (CO<sub>2</sub> emission) increases with growth (GDP) but declines after reaching maximum levels. Then we augment the traditional EKC framework by using renewable and non-renewable energy together with GDP. Moreover, we used spatial econometric techniques to quantify the direct and indirect (spillover) effects of renewable and non-renewable energy consumption on environmental degradation. For the spatial model, we need balanced data, therefore, our sample consists of 96 countries across the globe.

### **Results**

Before proceeding with the regression, we need to formally test, whether there is a spatial dependence among the variables of interest. For neighbourhood definition, we used the nearest neighbour definition for constructing the weight matrix for the neighbourhood. Particularly, we used 3 to 5 nearest neighbours to construct the binary weight matrix. After defining the weight matrix, Moran I and Geary's C tests are performed on each variable. Both Moran and Geary tests confirm the presence of spatial dependence among all variables, however, the test for trade variable is marginally significant in cross-section setup but significant in panel setup. After testing the spatial dependence, we applied a spatial econometric regression model to evaluate our model. In general, there are various types of spatial econometric models used in the literature (for detail, see Anselin and Bera, 1998; LeSage and Pace, 2009). For instance, SAR (spatial autoregressive model), SLX (Spatial Lagged X model), SEM (spatial error model), SDM (spatial Durbin model), and SDEM (spatial Durbin error model). The choice from these models is based on Likelihood Ratio (LR) test that is performed on the parameters of these models and we selected SDM model. The results from SDM model shows that the spillover effect of REC on CO<sub>2</sub> emissions is greater than the direct effect, which indicates that if there is a high level of REC in the neighbourhood, it will reduce the amount of CO<sub>2</sub> emissions in the current country. In contrast, the direct effect of NREC is more than the spillover effect, which means that country's CO<sub>2</sub> emissions will rise more due to the high level of NREC in the same country. These results also suggest that political bodies including energy planners, NGOs, international cooperation agencies and associated bodies in these countries perform together to increase the investment in renewable energy resources. This action will not only increase the amount of energy but also produce a lower amount of CO<sub>2</sub> in these countries.





## Conclusions

This study investigated the impact of energy consumption on environmental degradation using the Environmental Kuznets Curve (EKC) framework. We have used energy consumption in the form of two different energy concepts i.e. renewable energy consumption and non-renewable energy consumption. Additionally, we applied the spatial econometric method to examine the environmental Kuznets curve for CO<sub>2</sub> emissions by controlling the neighbourhood effects. Since there is a spatial dependence among the sources of CO<sub>2</sub> emissions, therefore, ignoring such effect might lead to biased results. This study applied both Moran and Geary tests confirm the existence of spatial dependence among all variables, however, test for trade variable is marginally significant in cross-section setup but significant in panel setup. The results of the study show that the spillover effect of REC on CO<sub>2</sub> emissions is greater than the direct effect, which indicates that if there is a high level of REC in the neighbourhood, it will reduce the amount of CO<sub>2</sub> emissions in the current country. In contrast, the direct effect of NREC is more than the spillover effect, which means that country's CO<sub>2</sub> emissions will rise more due to the high level of NREC in the same country. These findings also suggest that political governments including energy planners, NGOs, international cooperation agencies and associated bodies in these countries can work together to increase the capacity of renewable energy resources. It will help to produce a lower amount of CO<sub>2</sub> emissions in these countries

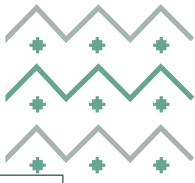
## References

Anselin, L., & Bera, A. K. (1998). Spatial dependence in linear regression models with an introduction to spatial econometrics. *Statistics textbooks and monographs*, 155, 237-290.

Kuznets, S. (1955). Economic Growth and Income Inequality. *The American Economic Review*, 45(1), 1-28.

LeSage, J., & Pace, R. K. (2009). *Introduction to spatial econometrics*. Chapman and Hall/CRC.





**[ADVANCING ENVIRONMENTAL STEWARDSHIP THROUGH CIRCULAR ECONOMY  
IN OIL & GAS FACILITY]**

[Mubarak Al-Rashid, Saudi Aramco, +966535329919, mubarak.rashid.1@aramco.com]

**Overview**

Oil and Gas remain critical components of the world's energy supply mix and there is an increasing need for minimizing the environmental impact associated with hydrocarbons. To address the trilemma of sustainability issues, including resources depletion, waste accumulation and ecosystem degradation, Abqaiq Plants, where over 5% of global oil production is processed, has established and embedded a systematic Circular Economy program for identifying business opportunities to reduce environmental impacts and GHG while improving economic and environmental sustainability.

**Methods**

A robust program, driven by an empowered team, developed initiatives covering the entire life cycle of plant operations. These initiatives target how systems are designed, promote and leverage circular economy processes, encourage sustainable consumption, and aim to ensure that waste is prevented and assets used are kept in service for as long as possible. The plan is built on PDCA model to drive constant improvements and is comprised of various steps starting from establishment of CE charter and ending with continuous improvement through Circularity assessment.

**Results**

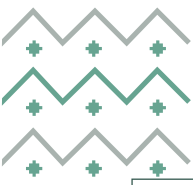
A comprehensive, multi-pronged implementation of circular economy has led to a transformation of the facility and yielded economic benefits alongside environmental benefits. These include:

- Re-utilizing Closed drain vessels resulting in reduced raw material requirements, associated emissions and savings of \$30MM
- Re-purposing mothballed piping to achieve process flexibility and savings of \$3 MM
- Implementing repair vs replace strategies to extend asset life and yielding \$1.5 MM in savings
- Reducing gas combustion by utilizing available waste streams to modify compressor drivers resulting in fuel gas and emission reductions.

**Conclusions**

The success of the program hinged on key enablers including developing human capital through awareness, training and upskilling as well as robust strategic planning embedded in energized work processes. This submission showcases the challenges and successes of adopting circular economy into a 70 year old facility to achieve the highest levels of environmental stewardship.

Saudi Aramco: Company General Use



## Baseline greenhouse gas forecasts for Saudi Arabia using the Structural Time Series Model and Autometrics

Anwar A. Gasim. KAPSARC, Saudi Arabia. +966 112 903 015 [Anwar.Gasim@kapsarc.org](mailto:Anwar.Gasim@kapsarc.org)

Lester C. Hunt. University of Portsmouth, UK. +44 239 284 4128, [Lester.Hunt@port.ac.uk](mailto:Lester.Hunt@port.ac.uk)

Jeyhun I. Mikayilov, KAPSARC, +966 112 903 098 [Jeyhun.Mikayilov@kapsarc.org](mailto:Jeyhun.Mikayilov@kapsarc.org)

### Overview

As a party to the Paris Agreement, Saudi Arabia submitted a baseline target to reduce its emissions as part of its nationally determined contribution (NDC). Baseline targets rest on the development of a baseline emissions scenario. Saudi Arabia's baseline scenario has not yet been made publicly available. In this paper we use two different econometric methods within a univariate framework to develop baseline greenhouse gas (GHG) emission forecasts, extending current drivers, trends, and policies into the future without the need to make assumptions about factors such as economic growth in the coming decades. The different methods are used since they provide a robustness check, as each method has its strengths and weaknesses. We therefore combine both methods by averaging to generate our baseline GHG emissions projections for Saudi Arabia.

### Methods

As far as we are aware, neither the STSM nor Autometrics have been used for GHG baseline forecasting. We use these two methods given their ability to explain the data with a combination of trends and interventions. These interventions can capture the effects of shocks and policy changes on GHG emissions, and their omission could lead to biased estimation results. Although both the STSM and Autometrics capture interventions, they differ in the way in which they do so.

To ensure comparability between the methods, we start the estimation procedure with a consistent general univariate model. In both approaches, we model the natural logarithm of the different GHG emissions (carbon dioxide – CO<sub>2</sub>, methane – CH<sub>4</sub>, and nitrous oxide – N<sub>2</sub>O) denoted generally by lower-case  $ghg_t$ , where  $t$  denotes the year. Four lags of the dependent variable are included to capture autoregressive behaviour in the general equations, and a 'preferred' or 'final' equation is obtained by adding statistically significant interventions (also known as dummy variables) and dropping the insignificant right-hand side variables while monitoring an array of diagnostic tests. The preferred estimated equations are then used to produce the baseline projections of the different GHG emissions for Saudi Arabia to 2060 with the final projections for each GHG being the average of the STSM and Autometrics projections, consistent with Enders (2015).

The Autometrics multipath-search machine-learning algorithm (Doornik and Hendry, 2018) is applied to the General-to-Specific (Gets) Modelling approach (Hendry and Doornik, 2014). This identifies potential interventions caused by policy changes and shocks, whose omission might cause biased estimation results. It automatically assigns one-time pulse, blip, change in level, and break in trend dummies to each observation and chooses the significant ones by utilizing the block-search algorithm. The Autometrics general specification utilised is therefore given by:

$$ghg_t = \alpha_0 + \alpha_1 ghg_{t-1} + \alpha_2 ghg_{t-2} + \alpha_3 ghg_{t-3} + \alpha_4 ghg_{t-4} + \sum_1^T \vartheta_i IIS_t + \sum_1^T \tau_i SIS_t + \sum_1^T \varphi_i DIIS_t + \sum_1^T \omega_i TIS_t + \varepsilon_t \quad (1)$$

where  $IIS_t$  is an Impulse-Indicator,  $SIS_t$  is a Step-Indicator,  $DIIS_t$  is a Differenced Impulse-Indicator Saturation, and  $TIS_t$  is a Trend-Indicator.  $\alpha_i, \vartheta_i, \tau_i, \varphi_i, \omega_i$  are regression coefficients to be estimated; and  $\varepsilon_t$  is a random error term  $\sim NID(0, \sigma_\varepsilon^2)$ .

The STSM models GHG emissions using a stochastic trend, which captures long-term movements in time series variables and can be extrapolated into the future (Harvey, 1989). For consistency the STSM general specification is:

$$ghg_t = \gamma_t + \alpha_1 ghg_{t-1} + \alpha_2 ghg_{t-2} + \alpha_3 ghg_{t-3} + \alpha_4 ghg_{t-4} + \varepsilon_t \quad (2a)$$

where  $\alpha_i$  are regression coefficients to be estimated,  $\gamma_t$  is a stochastic trend (or time varying intercept) and  $\varepsilon_t$  is a random error term  $\sim NID(0, \sigma_\varepsilon^2)$ . The stochastic trend is made up of a level  $\mu_t$  and a slope  $\beta_t$ , which are defined as follows:

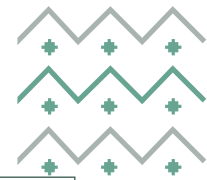
$$\mu_t = \mu_{t-1} + \beta_{t-1} + \eta_t \quad (2b)$$

$$\beta_t = \beta_{t-1} + \xi_t \quad (2c)$$

where  $\eta_t \sim NID(0, \sigma_\eta^2)$  and  $\xi_t \sim NID(0, \sigma_\xi^2)$  are mutually uncorrelated random disturbance terms. If the variances of either  $\eta_t$  or  $\xi_t$  are found to be zero, that component of the trend becomes deterministic. If both hyperparameters are found to be zero, the stochastic trend collapses into a deterministic trend. Like Autometrics, different types of dummy interventions can be identified and added to the model (Harvey and Koopman, 1992). These interventions capture important breaks and structural changes at certain dates during the estimation period. These interventions can be incorporated into the stochastic trend, which can be defined as follows:

$$\gamma_t = \mu_t + \text{irregular interventions (Irr}_t) + \text{level interventions (Lvl}_t) + \text{slope interventions (Slp}_t) \quad (2d)$$





## Results

The estimated preferred models for CO<sub>2</sub>, CH<sub>4</sub>, and N<sub>2</sub>O emissions for Saudi Arabia for both econometric techniques are given below:

$$CO_2 \text{ (1984-2019) Autometrics: } \widehat{co}_{2t} = 0.1421^* + 1.2878^{***}co_{2t-1} - 0.3079^{**}co_{2t-2} - 0.1857^{***}IIS_{1984} \quad (3)$$

$$CO_2 \text{ (1984-2019) STSM: } \widehat{co}_{2t} = \hat{\gamma}_t + 0.5803^{***}co_{2t-1} - 0.6591^{***}co_{2t-3} \quad (4a)$$

$$\text{with the estimated trend } (\hat{\gamma}_t) \text{ given by } \hat{\gamma}_t = \hat{\mu}_t - 0.0787^{***}Lvl_{1987} - 0.0638^{***}Irr_{1989} + 0.0882^{***}Lvl_{1991} + 0.0711^{***}Irr_{1996} + 0.0163^{**}Slp_{2001} + 0.0300^{**}Irr_{2010} - 0.0525^{***}Slp_{2015} \quad (4b)$$

$$CH_4 \text{ (1988-2019) Autometrics: } \widehat{ch}_{4t} = 1.3636^{***} + 0.6965^{***}ch_{4t-1} + 0.2069^*ch_{4t-2} - 0.1871^{**}ch_{4t-3} - 0.0566^{***}DIIS_{1999} - 0.0493^{***}DIIS_{2002} + 0.1135^{***}IIS_{1991} + 0.0072^{***}TIS_{2017} \quad (5)$$

$$CO_2 \text{ (1988-2019) STSM: } \widehat{ch}_{4t} = \hat{\gamma}_t + 0.5333^{***}ch_{4t-1} - 0.2007^*ch_{4t-2} + 0.3386^{***}\Delta ch_{4t-3} \quad (6a)$$

$$\text{with the estimated trend } (\hat{\gamma}_t) \text{ given by } \hat{\gamma}_t = 2.6706^{***} + 0.0160^{***}t - 0.1983^{***}Irr_{1989} - 0.0767^{***}Irr_{1999} - 0.0578^{***}Irr_{2009} \quad (6b)$$

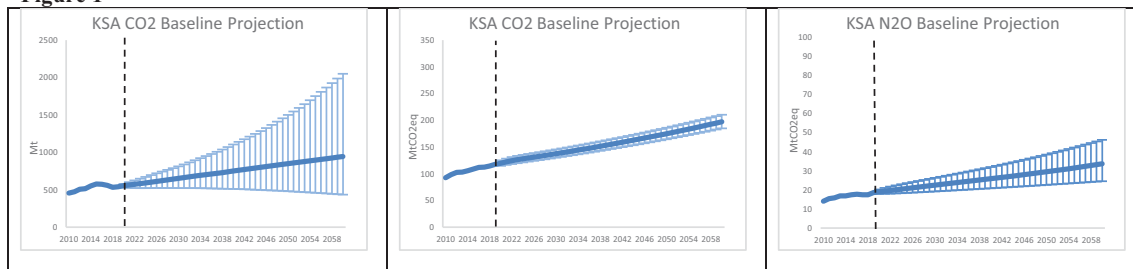
$$CH_4 \text{ (1984-2019) Autometrics: } \widehat{n_2o}_t = 0.4117^{***} + 0.8635^{***}n_2o_{t-1} - 0.0880^{***}DIIS_{1995} - 0.0719^{***}DIIS_{1996} + 0.0664^{***}SIS_{2007} - 0.1072^{***}SIS_{2009} \quad (5)$$

$$N_2O \text{ (1984-2019) STSM: } \widehat{n_2o}_t = \hat{\gamma}_t + 0.4089^{***}n_2o_{t-1} \quad (6a)$$

$$\text{with the estimated trend } (\hat{\gamma}_t) \text{ given by } \hat{\gamma}_t = \hat{\mu}_t - 0.0736^{***}Irr_{1995} - 0.1186^{***}Lvl_{2008} \quad (6b)$$

Where, the \*, \*\*, and \*\*\* represent coefficients' significance at the 10%, 5%, and 1% levels, respectively and  $\hat{\mu}_t$  represents the estimated level components of the trends. Each of these estimated equations are used to project emissions for Saudi Arabia up to 2060 and a simple average taken for each GHG to represent the baseline scenario given in Figure 1 with their 95% confidence intervals.

Figure 1



## Conclusions

Our baseline projections suggests that if current trends, drivers, and policies in 2019 were extended into the future and no further policies to curb emissions were undertaken, for Saudi Arabia, CO<sub>2</sub> emissions would grow from 540.4 Mt in 2019 to 651.2 Mt by 2030 and 944.4 Mt by 2060, CH<sub>4</sub> emissions would grow from 117.5 MtCO<sub>2</sub>eq in 2019 to 137.5 MtCO<sub>2</sub>eq by 2030 and to 197.2 MtCO<sub>2</sub>eq in 2060, and N<sub>2</sub>O emissions would grow from 18.6 MtCO<sub>2</sub>eq in 2019 to 22.4 MtCO<sub>2</sub>eq by 2030 and to 33.7 MtCO<sub>2</sub>eq in 2060.

Of course, there are large uncertainties around these estimates; nevertheless, the finalized projected baseline scenarios will be valuable tools for policymakers, providing an indication of the efforts needed to achieve Saudi Arabia's climate goals, in the near and long terms, and illustrating how much those efforts could push Saudi's baseline GHG emissions onto a more sustainable pathway.

## References

- Enders, W. 2015. Applied Econometrics Time Series. Hoboken, NJ: Wiley.
- Doornik, J. A., and Hendry, D. F. 2018. Empirical Econometric Modelling Using PcGive: Volume I, 8th Edition. London: Timberlake Consultants Press.
- Harvey, A. C., 1989. "Forecasting, Structural Time Series Models and the Kalman Filter." Cambridge University Press, Cambridge, UK.
- Harvey, A. C. and Koopman, S. J. 1992. Diagnostic checking of unobserved-components time series models. *Journal of Business & Economic Statistics*, 10, 377–389.
- Hendry D.F. and Doornik J.A. 2014. Empirical Model Discovery and Theory Evaluation. Automatic Selection Methods in Econometrics. The MIT Press, Cambridge, Massachusetts. London, England.





## ***DOES CLIMATE CHANGE AFFECT FEMALE EMPOWERMENT?***

Anna Maria Oosthuizen, University of Pretoria, [annerioost@gmail.com](mailto:annerioost@gmail.com)  
Roula Inglesi-Lotz, University of Pretoria, [roula.inglesi-lotz@up.ac.za](mailto:roula.inglesi-lotz@up.ac.za)

### **Overview**

**Women's empowerment** stimulates **further development**, enabling a **virtuous cycle** (Duflo, 2012). Duflo (2012) explains that female empowerment and economic development are closely related in multiple directions, where development can drive down inequality between men and women and empowering women can drive development. Making progress in either of these will set a virtuous cycle in motion. The persistence of gender inequality is most stark in sub-Saharan Africa, where 6 million women are missing every year. Women in developing countries face severe excess mortality but also meet differential impacts throughout their lives and before birth in many domains compared to their male counterparts. For every missing woman, even more, women lack education, jobs, and political responsibility that would have been obtained if they were male (Duflo, 2012). Diebolt and Perrin (2013) describe a virtuous cycle between female empowerment, human capital accumulation and endogenous technological progress, which triggered the demographic and economic transition.

Women and girls face distinct vulnerabilities stemming from cultural norms and lower socioeconomic status, further exacerbated by climate change. Domestic roles make women disproportionate users of natural resources, like water and firewood. Increased workloads also result in girls being pulled from school to help with the labour burden. Crop failure due to sporadic rainfall often results in selective malnourishment of girls and women, more pronounced in cultures where men eat before women. Malnourishment increases the risk of infections having severe health implications, and girls and women often do not have the means to access or pay for treatment (Kangas et al., 2014). Neumayer and Plümper (2007) show that natural disasters also have gender implications, claiming more women than men, which increases with the intensity of the natural disaster and lower socioeconomic status of women. Climate change affects men's and women's assets and wellbeing differently in agricultural production, food security, health, water and energy resources, climate-induced migration and conflict and natural disasters caused by climate change (Goh et al., 2012).

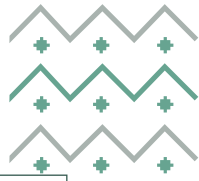
The main purpose of this paper is to analyse the impact of climate change on female empowerment in climate-vulnerable areas. In order to exploit sub-national variation linked to areas with different degrees of climate change vulnerability, individual-level empowerment metrics are constructed using the Demographic and Health Surveys (DHS).

### **Methods**

**Female empowerment** has been defined as the "process by which women gain power and control over their own lives and acquire the ability to make strategic choices" (EIGE, 2016). Female empowerment is often examined under the capability approach, which formulates a framework that regards human development as a process and follows the following dimensions: resources, capabilities, institutions, and functionings (Sen et al., 1997).

Following Rettig et al. (2020)'s methodology, this study constructs a Female Empowerment Index (FEMI) for all available DHS datasets. FEMI is built for women aged 15-19 years old and includes six empowerment dimensions, namely: Violence against women, Employment, Education, Reproductive healthcare, Decision making, and access to Contraception. FEMI is calculated as the mean proportion of positive outcomes in the six categories, where zero represents low levels of empowerment and one represents high levels of empowerment. The first objective is to evaluate the outcomes of each dimension of FEMI for each region nationally. Furthermore, to investigate the deterministic characteristics of female empowerment beyond the dimensions of FEMI, including occupation, income level, age, ethnicity, language, religion, rural vs urban, distance from the coast, individualistic vs collectivist societal structure, historical disease, historical plough use, history of hunter vs gatherer, slave-trade exposure and historical crop domination. Secondly, subnational variation within countries will be considered for a more in-depth perspective of FEMI mutation across provinces/states/regions.





Selected DHS datasets have accompanying geographic information systems (GIS) data, which records geographic information for respondents. GIS data allows researchers to link health data with health facilities, like local infrastructure and environmental conditions. The groupings of households that participated in the survey are geo-referenced clusters. The GPS readings for most clusters are accurate to less than 15 meters. To ensure respondent confidentiality, GPS coordinates are randomly displaced so that an urban cluster contains a minimum of zero and a maximum of two kilometres errors. The GIS data gives relatively accurate location data on each respondent that can easily be linked to the associated FEMI value. Furthermore, the DHS also provides Geospatial Covariates datasets which link cluster locations to ancillary data, which contains population, climate and environmental factors. In essence, individuals are linked with GIS and geospatial data. Population density, infrastructure development, and poverty levels, amongst others, can significantly impact the vulnerability of specific areas to extreme weather, flooding and other effects of climate change. Furthermore, the DHS collects many indicators for informing resilient climate development, which allows for vulnerability mapping and constructing an index of climate vulnerability/resilience (Guzmán, 2013). Geospatial Covariates allow for exposure indicators such as the proportion of people living in environmentally fragile areas. Sensitivity indicators provide information on the proportion of households by physical infrastructure, poverty levels, infant mortality rates and prevalence of malaria in children. Where adaptive capacity indicators give information on the proportion of people by age, sex and education status, access to electricity and improved water sources, and access to medical facilities. Beyond this, the DHS data can be used to define an aggregated index of resilience or vulnerability, which can be mapped at the cluster level.

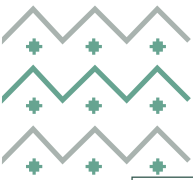
## Results

Climate change affects men and women differently regarding agricultural production, food security, health, water and energy resources, climate-induced migration and natural disasters (Goh et al., 2012). Women are more susceptible to the impacts of climate change and, therefore, can worsen gender inequality (Alston, 2013). However, Odo et al. (2021) show that higher levels of female empowerment have a higher probability of using clean fuel as the primary energy source for cooking, indicating that female empowerment can accelerate the transition to cleaner fuels. Improved female empowerment can play a crucial role in climate change mitigation. Literature states that climate change reflects and reinforces gender inequality; if that is the case, areas vulnerable to climate change should reflect lower levels of FE (Eastin, 2018). Results will decompose individual deterministic and demographic characteristics of FEMI, construct a climate change vulnerability/resilience index and map individual levels of FEMI with climate change vulnerability geographically to investigate the effect of climate change on female empowerment.

## Conclusions

Essential tools to empower women and girls include education; training; awareness raising, choice expansion, access and control over resources, and actions that transform patriarchal structures and institutions that perpetuate and reinforce gender inequality (EIGE, 2016). Highly persistent cultural norms and values are vital in determining gender inequality, gendered labour division, and economic and social outcomes for women (Davis and Williamson, 2019). Demographic data can assist in developing proactive and effective adaptation policies. This allows adaptation policies to be linked to the people most affected by climate change rather than the general perspective. Linking individual and community adoption, demography with geography and environmental and population dynamics (Guzmán, 2013). Rapid urbanisation and continuous growth of cities on coastlines move individuals towards areas of vulnerability, accompanied by others fleeing environmental disasters towards urban areas. Climate hazards have highly differential impacts shaping how individuals respond to environmental disasters. Identifying the population size, density, composition and characteristics of individuals exposed to climate risk are essential to adoption strategies. Climate change vulnerability can be mapped with socio-economic data to construct vulnerability/resilience indicators similar to poverty maps. The Geospatial Covariates and GIS data allow us to empirically map levels of female empowerment with climate vulnerability/resilience to test the associations between climate-related stressors and female empowerment.





**2050 Net-Zero Scenarios for Utilities in the Kingdom: Strategies to reduce emissions from the power sector**

Alassane Ndour, Rakan Alonazy, Young Ho Kwon, Mohammed AlNassar

Saudi Aramco, Utilities Planning Unit- S&LTPD- Power Systems Planning Department  
LIP - The Star Building - Dhahran 31311  
ndourax, alassane.ndour@aramco.com

**Abstract** - This paper presents roadmaps to reach net-zero emissions for the power sector in the Kingdom. While the Kingdom is implementing a comprehensive and articulated strategy to phase-out liquid fuel in the utilities and deploy 60 GW of renewables by 2030, there are legitimate questions on pathways to decarbonize an economy that heavily relies on hydrocarbons. If renewable technologies are boosting the transformation of energy sectors across the world and particularly the power sectors, main uncertainties and challenges remain when it comes to clean technologies costs and climate policies.

The power sector in the Kingdom will most likely reduce its greenhouse gases (GHG) by 40% in 2030 if the multiple programs on renewable and liquid displacement are realized. Successful achievement of the net-zero will require an extra effort on deploying the right mix of clean technologies including various renewable technologies, carbon capture utilization and storage (CCUS), and electric vehicles (EVs) supported by appropriate policies and markets/prices reforms.

Different scenarios to achieve the net-zero target in the Kingdom have been simulated using PLEXOS which optimizes long-term power & gas infrastructure considering environmental emission targets of CO<sub>2</sub> and utilization of CO<sub>2</sub> removal technologies. Generation and fuel mix to achieve the net-zero target from 2030 to 2050 will be proposed and presented with associated technologies and strategies to reduce environmental emissions from the power sector. Main policies to support the net-zero will be discussed.

**Key Words** – Net-zero, CCUS technologies, hydrogen, electrification, storage, energy efficiency, resilience, sustainability.

Saudi Aramco: Company General Use





## **PLASTICS TO OIL: SAUDI AND GLOBAL PERSPECTIVES**

Julio Arboleda, IAEE 27170, +966563750525, [julio.arboleda@kapsarc.org](mailto:julio.arboleda@kapsarc.org)  
Evar Umeozor, +15875807066, [evar.umeozor@kapsarc.org](mailto:evar.umeozor@kapsarc.org)  
Jitendra Roychoudhury, +966532846492, [jitendra.roychoudhury@kapsarc.org](mailto:jitendra.roychoudhury@kapsarc.org)

### **Overview**

Nowadays, it is impossible to think about our world without plastics. Based on synthetic organic polymers, plastic malleability offers several opportunities for liquid bottles, clothing, packaging, medical supplies, electronic goods, construction material, toys, etc. However, these attractive characteristics of plastics for several applications leads to the global problem of waste plastic disposal. Some applications, such as packaging, are usually designed for single-use purposes, resulting in a significant amount of plastic waste generation.

For that reason, scientists are currently looking for solutions to reduce the amount of plastic waste polluting the environment. Ideas such as using nano-cellulose to accelerate the biodegradation of polymers or genetics to increase the production of bioproducts that could replace plastic have emerged. However, such technologies are still in their early stages of development or deployment, yet the volume of plastics accumulated globally is already critical. Plastic pyrolysis technologies which enable the conversion of plastic wastes to crude oil are considered promising and commercially ready.

This report aims to provide a deep analysis of the potential of plastic-to-oil technologies globally and in Saudi Arabia, synthesizing various points of view of the authors to compare the pros and cons of promising technologies. The paper will also summarize the technical challenges and possible solutions.

### **Methods**

The analysis is based on data observation from different sources, resulting in investment data assessment of the plastic to oil potential, and presented in the final report. It also includes an analysis based on the industry's available bibliography. Finally, it brings everything together to synthesize the potential that the technology plastic-to-oil has and the challenges that this technology faces.

### **Results**

The final report summarizes the results of the data analysis about the potential of the technology of plastics-to-oil, providing numerical results and comparing them to the total oil production. It also summarizes the challenges and issues this technology faces and how they can be adequately treated. This technology can be considered as one of the circular carbon economy technologies of the oil industry, bringing options not only for the conversion of plastic to oil but also offering solutions to climate problems such as plastic disposal in the environment and profitable mechanisms for recycling.

### **Conclusions**

- The potential of the technology plastics-to-oil under the current technology is limited, but counting on further technology developments, the total potential is significant.
- Under the current recycling systems, the amount of raw material – waste plastic – collected is just a tiny portion of all the waste plastic generated.
- If the technology becomes profitable, the potential to transform the industry is significant.





## **Modelling Energy Price Reform Outcomes and Understanding the Determinants of Success**

Anwar A. Gasim, King Abdullah Petroleum Studies and Research Center (KAPSARC), +966548041989, anwar.gasim@kapsarc.org  
Lama Yaseen, King Abdullah Petroleum Studies and Research Center (KAPSARC), lama.yaseen@kapsarc.org  
Paolo Agnolucci, University College London (UCL), p.agnolucci@ucl.ac.uk  
Paul Ekins, University College London (UCL), p.ekins@ucl.ac.uk

### **Overview**

For many countries, energy price reform (also sometimes referred to as energy subsidy reform) can unlock fiscal, economic, and environmental benefits. This has driven energy price reform up the policy agenda. In many energy-exporting countries, the fall in international oil prices in late 2014 and the subsequent decrease in government revenue drove their reform plans. In many energy-importing countries, the rise of government debt has been the primary driver of energy price reform attempts. In other countries, growing concerns around climate change have prompted their efforts to reform energy prices.

Implementation of energy price reform can be challenging for policymakers. Some attempts to reform energy prices have been successful, delivering fiscal, economic, and environmental benefits to those countries. Other attempts have led to social unrest, causing governments to backtrack and reverse the energy price increases. Surprisingly, there is a lack of studies on energy price reform outcomes. Studying the lessons learned from past reform attempts can inform policymakers currently exploring how to reform energy prices effectively. To the best of our knowledge, this paper provides the first in-depth, comprehensive, qualitative and quantitative analysis of global energy price reform episodes and outcomes.

There appear to have been only three previous studies on energy price reform outcomes and determinants. In one of the few studies on this topic, the IMF (2013) reviewed 28 attempts to reform energy prices across various countries, categorizing the attempts into successful, partially successful, and unsuccessful. Of the 28 attempts, 12 were classified as successful, 11 as partially successful, and five as unsuccessful. The IMF (2013) then identified six barriers to reform: lack of information on the cost of subsidies, lack of government capacity, concerns over negative impacts on the poor, concerns over inflation and competitiveness, opposition from interest groups, and weak macroeconomic conditions. More recently, Natalini et al (2020) constructed a dataset with 59 instances of social unrest triggered by energy price increases, which they referred to as "fuel riots". They then explored the relationships between these fuel riots and various explanatory variables, focusing on the international oil price as a determinant. McCulloch et al (2021) used the same dataset on fuel riots developed by Natalini et al (2020) but explored the domestic gasoline price as a determinant alongside the international oil price. Both Natalini et al (2020) and McCulloch et al (2021) applied regression analysis to understand the determinants of fuel riots, while the IMF (2013) study used a qualitative analysis approach. Beyond these three studies, there is little else on modelling and understanding energy price reform outcomes.

### **Methods**

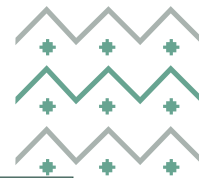
We categorize energy price reform outcomes using a definition of "success" established by Hill (2013) and Chelminski (2018), where they define a successful reform as one that is durable, that is, not overturned or reversed. On the other hand, we define an unsuccessful reform as one that is rolled back soon after it is launched, generally in response to social unrest.

Modelling the outcomes of energy price reform requires the construction of a new dataset that includes the reform outcomes, along with key explanatory variables. We build this dataset through a structured manual search of news databases, encompassing ProQuest, LexisNexis, and Factiva, from which we extract information on the outcome of the energy price reform, the extent of the energy price increases, the energy products that were targeted, and so on. The search is conducted systematically, combining keywords and operators to maximize search precision. We combine these results with the results from a search on social unrest from large-scale conflict databases, including GDEL, ACLED, and PRIO. Finally, we add data on country characteristics, most of which is obtained from the World Bank.

We analyze our newly constructed dataset, which includes around 200 episodes of energy price reform globally, using qualitative and quantitative methods to investigate the relationship between energy price reform outcomes and other explanatory variables. Our quantitative analysis rests on logistic regressions to investigate the relationship







between a binary dependent variable and a set of explanatory variables. We explore two distinct approaches within our logistic regression, which differ in the choice of dependent variable:

$$EPRSU_i = \beta_1 + \beta_2 x_{1i} + \beta_3 x_{2i} + \dots + \beta_n K x_{ni} + \varepsilon_i \quad [1]$$

where  $EPRSU_i$  is the occurrence of energy price-related social unrest in country  $i$ ,  $x_{ji}$  are the explanatory variables, and  $\varepsilon_i$  is the residual. This equation is similar to what was used by Natalini et al (2020) and McCulloch et al (2021), differing in the explanatory variables. The differences between our approach and the approaches used by Natalini et al (2020) and McCulloch et al (2021) are best illustrated through an example. Suppose Country A reformed diesel and kerosene prices, while Country B reformed residential electricity tariffs only. Let's also suppose that the former attempt at reform led to social unrest while the latter did not. Natalini et al (2020) would attempt to measure the relationship between the international crude oil price and the occurrence of social unrest, while McCulloch et al (2021) would attempt to measure the relationship between the domestic gasoline price and social unrest. In this example, both Natalini et al's (2020) and McCulloch et al' (2021) approaches may miss the true determinants, which our approach would not miss, since it captures all the price increases across all energy products during the reform. Furthermore, our newly constructed dataset allows us to isolate the domestic price changes that occurred due to reform from the domestic price changes that are driven by fluctuations in global fuel prices.

Our second approach sets the occurrence of a reversal as the dependent variable, with the same right-hand side explanatory variables:

$$R_i = \beta_1 + \beta_2 x_{1i} + \beta_3 x_{2i} + \dots + \beta_n K x_{ni} + \varepsilon_i \quad [2]$$

where  $R_i$  is the reversal of the reform. This equation has not previously been explored in the literature.

## Results

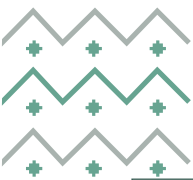
Analysis of our newly constructed dataset reveals the factors that increase or decrease the likelihood of a successful energy price reform outcome. We find that smaller energy price increases and the use of compensation both increase the likelihood of successful outcomes. Higher incomes, as measured by gross domestic product per capita, also increase the probability of success. On the other hand, we find that energy price reforms are less likely to succeed in lower-income countries, especially when implemented alongside price increases to other essential goods and services, such as food and telephone. Furthermore, when an initial attempt at energy price reform in a country leads to social unrest, we find that future attempts at reform, even if well-designed, will likely lead to an unsuccessful outcome. Finally, our analysis demonstrates that in some cases, depending on national circumstances, alternative policies to energy price reform may be better for achieving fiscal and environmental targets.

## Conclusions

To the best of our knowledge, this study is the first to build a comprehensive dataset of energy price reform episodes, stretching from 1990 to 2022, which are subsequently used to analyze and model the determinants of energy price reform outcomes. Given the considerable fiscal, economic, and environmental benefits that can be unlocked through energy price reform, many countries are currently exploring ways to reform energy prices, even though it can be challenging to do so. Drawing lessons from the experiences of governments that had previously attempted to reform energy prices, which we do through qualitative and quantitative analyses, such as logistic regression analysis, can yield insights that inform the design of future energy price reform programs.

## References

- Chelminski, Kathryn. 2018. "Fossil Fuel Subsidy Reform in Indonesia: The Struggle for Successful Reform," Chapter 11:193-211 in "The Politics of Fossil Fuel Subsidies and Their Reform," edited by Jakob Skovgaard and Harro Van Asselt, Cambridge University Press.
- Hill, Hal. 2013. "The Political Economy of Policy Reform: Insights from Southeast Asia," *Asian Development Review*, 30(1): 108-130.
- IMF. 2013. "Energy Subsidy Reform: Lessons and Implications," International Monetary Fund.
- McCulloch, Neil, Davide Natalini, Naomi Hossain, and Patricia Justino. 2021. "An Exploration of the Association Between Fuel Subsidies and Fuel Riots," Institute of Development Studies, Working Paper 2021-556.
- Natalini, Davide, Giangiacomo Bravo, and Edward Newman. 2020. "Fuel riots: definition, evidence, and policy implications for a new type of energy-related conflict," *Energy Policy* 147.



## ***[QUANTIFYING THE NON-LINEAR IMPACT OF EXTREME TEMPERATURES ON POWER GENERATION EFFICIENCY]***

[Jineon Moon, Center for Sustainable Development (CSD), KAIST, +82 10 2059 2460, jemoon94@kaist.ac.kr]  
[Jiyong Eom, School of Business and Technology Management (BTM), KAIST, +82 2 958 3511, eomjiyong@kaist.ac.kr]

### **Overview**

The electricity generation sector contributes to climate change while at the same time being exposed to physical and financial risks due to climate change-related extreme weather. Thermal power plants, in particular, are vulnerable to abnormal air or water temperature as the turbine cycle of power generation requires an external source of water and air for cooling (Linnerud et al., 2011; Zamulda et al., 2013; Jalgom et al., 2014). Several studies have tried to estimate the effect of external temperatures on power generation. Some examined macro indicators such as electricity market price (Boogert and Dupont, 2005; McDermott and Nilsen, 2014), whereas others estimated the efficiency loss from high temperatures. However, their approaches are limited to either a time series analysis of one example unit (Şen et al., 2018) or empirical research based on a linear impact model (Herny and Praston, 2016; Coffel and Mankin, 2021).

This paper quantifies the impact of extreme air temperatures on power generation efficiency based on a large panel dataset consisting of 1,742 thermal power plants covering the period between January 2008 and December 2020. Also importantly, our model explicitly represents the possible nonlinear response of power generation efficiency to extreme temperatures, acknowledging that linear models can underestimate the physical impact of extreme weather and associated business risks. We expect that a precise estimation of climate impacts on physical assets like the one undertaken here would be a prerequisite for assessing climate-related financial risks faced by enterprises such as electric utilities.

### **Methods**

Our study extends the semi-parametric panel fixed effect model proposed by Schlenker and Roberts (2009) to the U.S. power sector context. The model specifies a flexible nonlinear relationship between the temperature exposure of individual regions and the efficiency of power generation units in those regions, taking step functions, polynomial bases, and natural cubic spline approaches. In addition, individual fixed effects control for time-independent plant unit-specific heterogeneity in plant operation patterns. Moreover, extra explanatory variables, including time-varying, plant unit-specific capacity factors, and individual plant ages, are selected to control other sources of efficiency loss.

The study draws on historical weather information from PRISM Climate Data and plant-level data from the U.S. Energy Information Administration (EIA). These two datasets are merged at the county and year-month levels to quantify the main variables. As a measure of county-level exposure to extreme temperatures, we employ the monthly distribution of temperatures for each county rather than the monthly average or min-max values. The open-source R codes for generating the distribution are provided by Ortiz-Bobea (2021). In addition, for power generation efficiency, we use 'heat rate,' which is the amount of energy input in MMBtu required to produce one kWh of the net generation.

### **Results**

The preliminary results indicate that exposure to moderate air temperature does not have a statistically significant impact on the heat rate of electricity generation. However, exposure to temperature over a certain threshold has the effect of increasing the heat rate. For example, with natural cubic spline bases with six degrees of freedom, one additional day of exposure to 35 °C bin lowers the generation efficiency on average by a half percent (Figure 1). Although the exact marginal effects vary with the specification of the function and degrees of freedom of the bases, the existence of the impact and the nonlinearity pattern remain robust. On top of that, the study additionally estimated the effects in separate climate regions to consider the possible regional differences of the power plants constructed to adapt to the specific climates. However, the results are generally similar to those that cover the entire contiguous U.S.



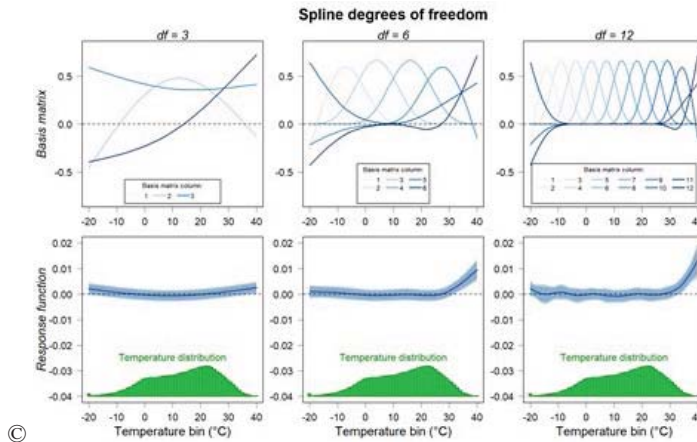
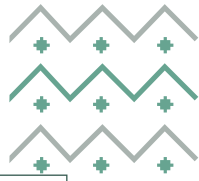


Figure 1. Nonlinear effect of air temperature on monthly heat rate of thermal power plant generators in the U.S.

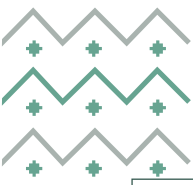
## Conclusions

Our preliminary results suggest that increasing periods with high temperatures can deteriorate the profitability of power plant owners as more energy should be supplied to generate the same amount of electricity. Of course, other critical factors, such as electricity price and system demand, can also explain profitability. Our study contributes to the literature on the assessment of climate-related physical risk, revealing one specific direct channel by which climate change can negatively influence business operations, that is, the impact of extreme temperatures on the efficiency of thermoelectric power generation.

## References

- Boogert, A. and Dupont, D. Y., 2005. The Nature of Supply Side Effects on Electricity Prices: The Impact of Water Temperature. *Economic Letters*, 88(1), 121-125.
- Coffel, E. D. and Mankin, J. S., 2021. Thermal Power Generation is Disadvantaged in a Warming World. *Environmental Research Letters*, 16(2), 024043.
- EIA., 2021. Form EIA-860 Detailed Data: [www.eia.gov/electricity/data/eia860/](http://www.eia.gov/electricity/data/eia860/), Retrieved 1 June 2022.
- EIA., 2021. Form EIA-923 Detailed Data: [www.eia.gov/electricity/data/eia923/](http://www.eia.gov/electricity/data/eia923/), Retrieved 23 May 2022.
- Henry C. L. and Praston, L. F., 2016. Effects of Environmental Temperature Change on the Efficiency of Coal- and Natural Gas-Fired Power Plants. *Environmental Science & Technology*, 50(17), 9764-9772.
- Jaglom, W. S. et al., 2014. Assessment of Projected Temperature Impacts from Climate Change on the U.S. Electric Power Sector Using the Integrated Planning Model®. *Energy Policy*, 73, 524-539.
- McDermott, G. R. and Nilsen, Ø. N., 2014. Electricity Prices, River Temperatures, and Cooling Water Scarcity, *Land Economics*, 90(1), 131-148.
- Linnerud, K., Mideksa, T. K., and Eskeland, G. S., 2011. The Impact of Climate Change on Nuclear Supply, *The Energy Journal*, 32(1), 149-168.
- Ortiz-Bobea, A., 2021. Chapter 76 - The Empirical Analysis of Climate Change Impacts and Adaptation in Agriculture. *Handbook of Agricultural Economics*, Volume 5, 3981-4073.
- PRISM Climate Group, PRISM Gridded Climate Data. Oregon State University, <https://prism.oregonstate.edu>, Data created 31 Dec 2020, Accessed 22 May 2022.
- Schlenker, W. and Roberts, M. J., 2009. Nonlinear Temperature Effects Indicate Severe Damages to U.S. Crop Yields under Climate Change. *Proceedings of the National Academy of Sciences*, 106(37), 15594-15598.
- Şen, G. et al., 2018. The Effect of Ambient Temperature on Electric Power Generation in Natural Gas Combined Cycle Power Plant-A Case Study. *Energy Reports*, 4, 682-690.
- Zamuda, C. et al., 2013. US Energy Sector Vulnerabilities to Climate Change and Extreme Weather. Department of Energy, Washington DC.





## Forecasting Saudi Arabia's 2060 Carbon Dioxide Emission Pathways: A Multivariate Approach

Abdullah Darandary, KAPSARC, Saudi Arabia. +966 112 903 015 [Abdullah.Darandary@kapsarc.org](mailto:Abdullah.Darandary@kapsarc.org)

Anwar A. Gasim, KAPSARC, Saudi Arabia. +966 112 903 015 [Anwar.Gasim@kapsarc.org](mailto:Anwar.Gasim@kapsarc.org)

Lester C Hunt, University of Portsmouth, UK. +44 239 284 4128, [Lester.Hunt@port.ac.uk](mailto:Lester.Hunt@port.ac.uk)

Jeyhun I. Mikayilov, KAPSARC, +966 112 903 098 [Jeyhun.Mikayilov@kapsarc.org](mailto:Jeyhun.Mikayilov@kapsarc.org)

### Overview

Saudi Arabia, a party to the Paris agreement, has committed under its new nationally determined contribution to become carbon net-zero by 2060. However, Saudi Arabia's baseline emission scenario has not been made public. This paper uses STSM<sup>1</sup> and Autometrics techniques to model two emission paths through a multivariate approach that factors in various emission impacting variables, such as GDP, aggregate energy price index, and value-added sectors. We forecast emission paths based on our estimated models and extend them to the future to provide two projections. These scenarios differ in their estimation and the underlying assumptions. Our preliminary projections assume no additional policies to curb emissions will be undertaken. Under these assumptions, CO<sub>2</sub> emissions in Saudi Arabia would grow from 540 Mt in 2019 to 944 Mt, as a lower bound, and up to 1228 Mt by 2060, based on the chosen model.

### Methods

To our knowledge, multivariate STSM and Autometrics has not been used for GHG baseline forecasting for Saudi Arabia. We take advantage of two methods to explain the data with unique abilities to capture trends and interventions throughout time. These interventions allow us to reflect the impact of shocks and policy change on GHG emissions, and their omission can lead to biased estimation. It is worth noting that while both STSM and Autometrics capture interventions, they differ in the approach.

The estimation procedure starts with a consistent general model to ensure model comparability between the methods with both approaches modelling the natural logarithm of Saudi CO<sub>2</sub> emissions (Mt) denoted by lower-case  $co_{2t}$  with a vector of drivers  $\mathbf{X}_t$  where  $t$  denotes the year. An autoregressive behaviour in the general equations is included, and a 'preferred' or 'final' equation is obtained by adding statistically significant interventions (also known as dummy variables) and dropping the insignificant right-hand side variables while monitoring an array of diagnostic tests. The preferred estimated equations are then used to produce the projections of Saudi CO<sub>2</sub> emissions to 2060 with the final projections being the average of the STSM and Autometrics projections, which is consistent with Enders (2015).

The Autometrics multipath-search machine-learning algorithm (Doornik and Hendry, 2018) is applied to the General-to-Specific (Gets) Modelling approach (Hendry and Doornik, 2014). This identifies potential interventions caused by policy changes and shocks, whose omission might cause biased estimation results. It automatically assigns one-time pulse, blip, change in level, and break in trend dummies to each observation and chooses the significant ones by utilizing the block-search algorithm. The Autometrics general specification utilised is therefore given by:

$$co_{2t} = \alpha_0 + \alpha_1 co_{2t-1} + \alpha_2 \mathbf{X}_t + \alpha_3 \mathbf{X}_{t-1} + \sum_1^T \vartheta_i IIS_t + \sum_1^T \tau_i SIS_t + \sum_1^T \varphi_i DIIS_t + \sum_1^T \omega_i TIS_t + \varepsilon_t \quad (1)$$

where  $co_{2t}$  is the natural logarithm of Saudi CO<sub>2</sub> emissions (Mt) in year  $t$ ,  $\mathbf{X}_t$  is a vector of drivers in year  $t$ ,  $IIS_t$  is an Impulse-Indicator,  $SIS_t$  is a Step-Indicator,  $DIIS_t$  is a Differenced Impulse-Indicator Saturation, and  $TIS_t$  is a Trend-Indicator.  $\alpha_i, \vartheta_i, \tau_i, \varphi_i, \omega_i$  are regression coefficients to be estimated; and  $\varepsilon_t$  is a random error term  $\sim NID(0, \sigma_\varepsilon^2)$ .

The STSM models GHG emissions using a stochastic trend, which captures long-term movements in time series variables and can be extrapolated into the future (Harvey, 1989). For consistency the STSM general specification is:

$$co_{2t} = \gamma_t + \alpha_1 co_{2t-1} + \alpha_2 \mathbf{X}_t + \alpha_3 \mathbf{X}_{t-1} + \varepsilon_t \quad (2)$$

where  $co_{2t}$ ,  $\mathbf{X}_t$ , and  $\alpha_i$  are as defined above,  $\gamma_t$  is a stochastic trend (or time varying intercept) and  $\varepsilon_t$  is a random error term  $\sim NID(0, \sigma_\varepsilon^2)$ . The stochastic trend is made up of a level  $\mu_t$  and a slope  $\beta_t$ , which are defined as follows:

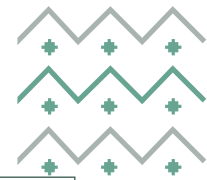
$$\mu_t = \mu_{t-1} + \beta_{t-1} + \eta_t \quad (3a)$$

$$\beta_t = \beta_{t-1} + \xi_t \quad (3b)$$

where  $\eta_t \sim NID(0, \sigma_\eta^2)$  and  $\xi_t \sim NID(0, \sigma_\xi^2)$  are mutually uncorrelated random disturbance terms. If the variances of either  $\eta_t$  or  $\xi_t$  are found to be zero, that component of the trend becomes deterministic. If both hyperparameters are found to be zero, the stochastic trend collapses into a deterministic trend. Like Autometrics, different types of dummy interventions can be identified and added to the model (Harvey and Koopman, 1992). These interventions capture

<sup>1</sup> STSM refers to Structural Time Series Model





important breaks and structural changes at certain dates during the estimation period. These interventions can be incorporated into the stochastic trend, which can be defined as follows:

$$\gamma_t = \mu_t + \text{irregular interventions } (Irr_t) + \text{level interventions } (Lvl_t) + \text{slope interventions } (Slp_t) \quad (4)$$

### Results

So far, we have estimated the two sets of models highlighted below (both for the period 1985-2019). Further sets will be considered. In the first set,  $X_t$  consists of the natural logarithms of real GDP ( $gdp_t$ ) and the real energy price ( $p_t$ ). The preliminary estimated preferred models for this set for both Autometrics and the STSM, respectively are given by:

$$\widehat{co}_2_t = 5.3332^{***} + 0.1306^{**} gdp_t - 0.1366^{***} p_t - 0.0540^{**} SIS_{1986} + 0.0588^{***} TIS_{1992} - 0.0548^{***} TIS_{1993} + 0.0437^{***} TIS_{2015} \quad (5)$$

$$\widehat{co}_2_t = \hat{\gamma}_t + 0.1913^{**} gdp_t - 0.1324^{***} p_t \quad (6a)$$

$$\text{with the estimated trend } (\hat{\gamma}_t) \text{ given by } \hat{\gamma}_t = \hat{\mu}_t + 0.0500^{**} Irr_{1988} \quad (6b)$$

For the second set, in the general model  $X_t$  consisted of the natural logarithms of Value Added for Agriculture ( $agrva_t$ ), Manufacturing ( $manva_t$ ), and Services ( $servva_t$ ), and the real energy price ( $p_t$ ). After testing down, the preliminary estimated preferred models for this set for both Autometrics and the STSM, respectively are given by:

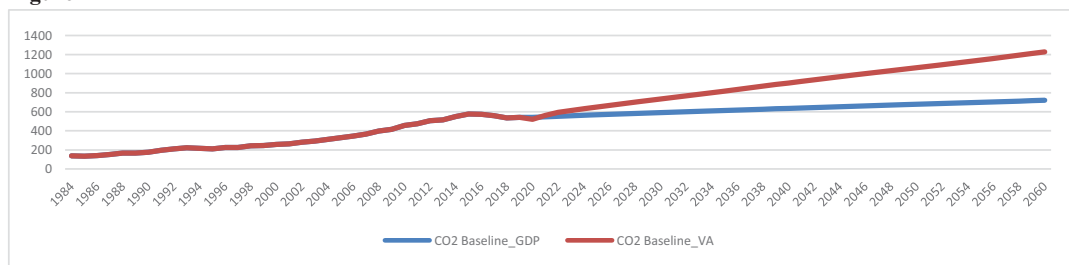
$$\widehat{co}_2_t = -2.2140^{***} + 0.4052^{***} co_{2,t-1} + 0.7342^{***} manva_t - 0.2504^{***} manva_{t-1} - 0.0483^{***} p_t + 0.0459^{**} IIS_{2002} - 0.0985^{***} SIS_{1990} + 0.0661^{***} SIS_{1993} + 0.0562^{***} TIS_{1987} - 0.0521^{***} TIS_{1996} + 0.0507^{***} TIS_{1997} \quad (7)$$

$$\widehat{co}_2_t = \hat{\gamma}_t + 0.3986^{***} manva_t + 0.4875^{***} agrva_t - 0.1054^{***} p_t \quad (8a)$$

$$\text{with the estimated trend } (\hat{\gamma}_t) \text{ given by } \hat{\gamma}_t = \hat{\mu}_t + 0.0500^{**} Lvl_{1991} \quad (8b)$$

Where, the \*, \*\*, and \*\*\* represent coefficients significant at the 10%, 5%, and 1% levels, respectively and  $\hat{\mu}_t$  represents the estimated level component of the trend. Each of the estimated equations in each set are used to produce projections for Saudi CO<sub>2</sub> emissions up to 2060 and an average taken within each set to produce the baseline scenarios (CO<sub>2</sub> Baseline GDP and CO<sub>2</sub> Baseline VA) shown Figure 1.

Figure 1



### Conclusions

Our preliminary baseline projections suggest that if current trends, drivers, and policies in 2019 were extended into the future and no further policies to curb emissions were undertaken, for Saudi Arabia, CO<sub>2</sub> emissions would grow from 540 Mt in 2019 to 944 Mt in 2060, and up to 1228 Mt by 2060 based on the chosen model. It is important to note that there are significant uncertainties around these estimates. The finalized projected baseline scenarios will be valuable tools for policymakers, highlighting the efforts needed to achieve Saudi Arabia's climate goals. It will illustrate how those efforts could push Saudi's baseline GHG emissions onto a more sustainable pathway.

### References

Enders, W. 2015. Applied Econometrics Time Series. Hoboken, NJ: Wiley.  
Doornik, J. A., and Hendry, D. F. 2018. Empirical Econometric Modelling Using PcGive: Volume I, 8th Edition. London: Timberlake Consultants Press.  
Harvey, A. C., 1989. "Forecasting, Structural Time Series Models and the Kalman Filter." Cambridge University Press, Cambridge, UK.  
Hendry D.F. and Doornik J.A. 2014. Empirical Model Discovery and Theory Evaluation. Automatic Selection Methods in Econometrics. The MIT Press, Cambridge, Massachusetts. London, England.







## ***EMISSIONS PRICING INSTRUMENTS WITH INTERMITTENT RENEWABLES: SECOND-BEST POLICY***

Nandeeta Neerunjun, Aix-Marseille School of Economics, France, +33 6 95 55 38 85, [nandeeta.neerunjun-demaiziere@univ-amu.fr](mailto:nandeeta.neerunjun-demaiziere@univ-amu.fr)

### **Overview**

Renewable energy sources play an essential role in reducing fossil fuel-based electricity production. They provide both greenhouse gas and air emissions benefits. Subsequently, emissions pricing measures that have been launched to meet regional to subnational emissions reduction goals are also expected to support an electricity mix in favor of renewables. Wind and solar energy are key to increasing renewables-based production (IEA 2021) but depend on variable and uncontrollable conditions resulting in intermittent electricity. This intermittence raises concerns over balancing electricity production and consumption which calls for flexibility in the markets. This paper studies to what extent an emissions pricing policy is efficient in response to intermittency.

Emissions pricing puts a price on each unit of emissions to capture negative externalities related to fossil-fueled electricity. It increases the variable production cost of fossil-fueled electricity and incentivizes a shift towards renewable technologies. Emissions pricing can take the form of a price-based instrument such as an emissions tax, usually referred to as the Pigouvian tax (Pigou 1960). An alternative to emissions taxation is a quantity-based instrument such as an Emissions Trading Scheme, ETS for short (Dales 1968, Montgomery 1972). Under conditions of certainty, the economic theory envisions the efficient tax or permit price under the ETS, as one that is equal to the marginal social damage. In addition, the two instruments have identical economic outcomes (Weitzman 1974).

However, ensuring an optimal regulation may be challenging in the presence of intermittent renewables. They induce variability in the electricity markets. Consequently, the social planner must decide on the policy while anticipating future variable levels of electricity consumption, production, and associated social damage. Hence, this paper studies how intermittency affects the efficiency of emissions pricing instruments. A question that also arises is whether the tax can still be equivalently implemented by an ETS. Therefore, I assess if the level of the tax differs from that of the permit price when an ETS is administered.

### **Methods**

To investigate the implication of intermittent renewables for an optimal emissions pricing policy, I propose a stylized theoretical model of the electricity sector. Electricity production is ensured by a mix of an existing fossil-fired power plant (e.g. coal) and investment in a renewable-based technology (e.g. wind turbine). The fossil-fueled technology produces uninterrupted electricity but causes emissions. The renewable technology is emissions-free but produces electricity that depends on variable conditions, hereafter also referred to as states of nature (e.g. wind (un)availability). In line with the current situation, I assume no electricity storage capacity where the two coexisting technologies supply electricity to match demand reliably.<sup>6</sup> Intermittency is captured through competitive wholesale markets that are state-dependent: electricity production is state-dependent and is traded at state-dependent prices.

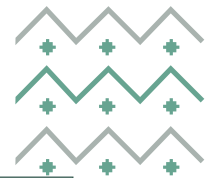
Electricity demand comes from consumers described according to their retail electricity tariffs. Most commonly, consumers have a flat-rate tariff. They are billed at a fixed price that is independent of the state of nature that drives production. This tariff does not convey information on varying electricity production to which consumers do not necessarily adapt their consumption. Flexibility is introduced on the demand side of the electricity markets when consumers move to state-dependent tariffs. They can adapt their electricity usage to varying production.

The social planner is concerned with implementing the first-best emissions pricing policy whose purpose is two-fold. It must be able to internalize the externalities that become severe for high levels of emissions from fossil-fueled electricity. In addition, the policy must implement the electricity production plan and consumption allocation that ensure social welfare. In principle, an emissions pricing policy as an incentive-based measure is an ex-ante regulation. The social planner announces the policy in anticipation of future consumption, production, and damage levels.

### **Results**

My model shows that an ex-ante emissions tax remains a second-best regulation when consumers move from the flat-rate to state-dependent tariffs. When consumption is constrained due to consumers on the flat-rate tariff, I find that an emissions tax does not implement the constraint social welfare allocation. The integration of the intermittent renewable results in different levels of fossil-fueled electricity production and associated marginal





damage that do not match the tax. For a similar explanation, even when consumers are flexible and can adapt their consumption to changing electricity production, I find that the social welfare allocation is unreachable with a tax.

Secondly, I find that in addition to flexibility on the demand side, introducing flexibility at the policy level through an Emissions Trading Scheme is second-best as well. I study the ETS as a flexible market-based regulation. While the emissions cap is set ex-ante, the emissions permits are traded ex-post on state-dependent markets. My model suggests that the economic agents anticipate that the social planner has the possibility to implement different levels of emissions cap to regulate emissions from variable fossil-fueled electricity production. Ultimately, no matter which cap is set, I show that it leads to ex-post inefficient permits prices as they do not match the marginal damage.

Finally, the results of my model indicate that the economic outcomes of administering the ETS are not the same as those when the emissions tax is implemented. The cap set by the social planner leads to prices of permits that differ in each state of nature while the emissions tax is uniform across the states. It implies that the two emissions pricing instruments are not implemented equivalently. While ranking the instruments is out of the scope of this work, I can only conclude that in the presence of intermittent renewables, the best that can be achieved with emissions pricing instruments is a second-best policy.

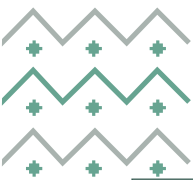
## Conclusions

The results show that accounting for intermittency has non-trivial implications for incentive-based emissions pricing instruments when incremental damage due to emissions is increasing. The key to achieving efficiency points to a state-dependent policy. It implies the emissions tax rate or cap must be tailored to the availability of the renewable resource. In the model, intermittency is captured through 2 states of nature which are sufficient to show distortions in the markets but in the real world, there are certainly more than 2 states. In this respect, it is hard to imagine implementing a state-dependent policy, for instance, for institutional reasons. It implies managing a regulation with a level of granularity matching that of the states of nature. Moreover, the policy may lose its incentive character to trigger long-term investment in renewables if it is administered ex-post rather than ex-ante.

## References

- Abrell, J., Rausch, S., Streitberger, C., 2019. The economics of renewable energy support. *Journal of Public Economics* 176, 94–117.
- Adar, Z., Griffin, J. M., 1976. Uncertainty and the choice of pollution control instruments. *Journal of Environmental Economics and Management* 3 (3), 178–188.
- Ambec, S., Crampes, C., 2012. Electricity provision with intermittent sources of energy. *Resource and Energy Economics* 34 (3), 319–336.
- Ambec, S., Crampes, C., 2019. Decarbonizing Electricity Generation with Intermittent Sources of Energy. *Journal of the Association of Environmental and Resource Economists* 6 (6), 1105–1134.
- Ambec, S., Crampes, C., 2021. Real-time electricity pricing to balance green energy intermittency. *Energy economics* 94, 105074.
- Bielecki, A., Ernst, S., Skrodzka, W., Wojnicki, I., 2020. The externalities of energy production in the context of development of clean energy generation. *Environmental Science and Pollution Research International* 27 (11), 11506–11530.
- Chiba, F., Rouillon, S., 2020. Intermittent Electric Generation Technologies and Smart Meters: Substitutes or Complements. *Revue d'économie politique* 130 (4), 573–613.
- Cochran, J., Miller, M., Zinaman, O., Milligan, M., Arent, D., Palmintier, B., O'Malley, M., Mueller, S., Lannoye, E., Tuohy, A., Kujala, B., Sommer, M., Holttinen, H., Kiviluoma, J., Soonee, S. K., 2014. *Flexibility in 21st Century Power Systems*.
- Crawley, G. M., 2013. *The World Scientific Handbook of Energy*. World Scientific.
- Dales, J. H., 1968. *Pollution, Property and Prices*. University Press, Toronto.
- EURELECTRIC, 2014. *Flexibility and Aggregation. Requirements for their interaction in the market*.
- Helm, C., Mier, M., 2018. Subsidising renewables but taxing storage? second-best policies with imperfect carbon pricing. *Oldenburg Discussion Papers in Economics* V-413-18, Oldenburg.
- Helm, C., Mier, M., 2019. On the efficient market diffusion of intermittent renewable energies. *Energy Economics* 80, 812–830.
- Hepburn, C., Stern, N., Stiglitz, J. E., 2020. "Carbon pricing" special issue in the *European economic review*. *European economic review* 127, 103440.
- IEA, 2011. *Harnessing Variable Renewables: A Guide to the Balancing Challenge*. OECD Publishing, Paris.
- IEA, 2021. *Renewables 2021. Report*, International Energy Agency, Paris.
- IEA-ISGAN, 2019. *Power Transmission & Distribution Systems. Flexibility needs in the future power system*.
- IRENA, 2018. *Renewable power generation costs in 2017*.
- Kaffine, D. T., McBee, B. J., Ericson, S. J., 2020. Intermittency and CO2 reductions from wind energy. *The Energy Journal* 41 (5). Labandeira, X., Labeaga, J. M., Rodríguez, M., 2004. Green tax reforms in Spain. *European Environment* 14 (5), 290–299.
- Lazard, 2018. *Lazard's levelized cost of energy analysis: Version 12.0*.
- Meng, S., 2014. How may a carbon tax transform Australian electricity industry? a CGE analysis. *Applied Economics* 46 (8), 796–812.
- Montgomery, W. D., 1972. Markets in licenses and efficient pollution control programs. *Journal of Economic Theory* 5 (3), 395–418.
- Pigou, A. C., 1960. *The Economics of Welfare*, 4th Edition. Macmillan, London.
- Prasad, M., Munch, S., 2012. State-level renewable electricity policies and reductions in carbon emissions. *Energy Policy* 45, 237–242.
- Rosenbloom, D., Markard, J., Geels, F. W., Fuenfschilling, L., 2020. Why carbon pricing is not sufficient to mitigate climate change and how "sustainability transition policy" can help. *Proceedings of the National Academy of Sciences* 117 (16), 8664–8668.
- Rouillon, S., 2015. Optimal and Equilibrium Investment in the Intermittent Generation Technologies. *Revue d'économie politique* 125 (3), 415–452.
- Twoney, P., Neuhoff, K., 2010. Wind power and market power in competitive markets: Large-scale wind power in electricity markets. *Energy Policy* 38 (7), 3198–3210.
- Weitzman, M., 1974. Prices vs. quantities. *Review of Economic Studies* 41 (4), 477–491.





# WILL CURRENT GLOBAL CLIMATE GOVERNANCE DELIVER?

By: Nadhmi Alkhamis  
Phone: 0598448805  
Email: [nadhmi.alkhamis@gmail.com](mailto:nadhmi.alkhamis@gmail.com)

## THE MAIN THESIS

The Global climate governance (GCG) that is currently pursued may face a “reality chasm” between what domestic actors can deliver and the Paris agreement obligations. Multilevel, multi-scalar, and multiplex governance structures have emerged over the years in response to the complex climate change issue. **Can GCG establish the required influence channels on domestic actors to forge the intended energy transition toward NetZero by 2050?**

## BACKGROUND

GCG has gradually evolved from a 'top-down' model to a more inclusive model, involving to a greater extent social and economic partners, and over time also domestic actors, throughout the policy cycle. As time runs out to mitigate greenhouse gases, GCG is “*at the crossroads*” and that important choices lie ahead in the immediate future.

The issue of climate change is multidimensional and cuts across several policy areas, particularly environmental, economic, and foreign policy. Most decisions regarding climate change made at the global level are *not binding* and the implementation relies on the effectiveness of GCG to influence domestic actors. Consequently, it is reasonable to assume that the paradigms that operate in each of these policy areas have contributed to domestic actors' understanding of the climate change problem and the most appropriate way to respond to it.

The cross-border, cross-sectoral, and multi-stakeholder nature of many global governance initiatives has in turn meant that GCG has become increasingly Multilevel Governance. The network of governments was transformed whereby the authority of decision-making and policy planning was reallocated into a system of multilevel governance. The framework of domestic governance comprises modes of governing in which the state plays a less authoritative role, that is, modes of governing that do not exclusively rely on the sovereign authority, legitimacy, or sanctions of governments for their governing capacity. Thus, domestic actors have more autonomy in their own decisions. This means that both public and private actors are engaged in policy networks, voluntary self-regulating arrangements, and non-coercive forms of state governing or voluntary agreements.

More autonomous domestic governance stakeholders are increasingly viewed as an innovative force driving climate change mitigation and adaptation efforts. GCG requires that in taking a coproduction approach, knowledge and policy innovation can transcend the domestic and permeate across all tiers of domestic and global governance. However, the capacity of domestic stakeholders to pursue autonomous actions is partially dependent on the delivery of adequate resources from other tiers of governance. Also, coordination means bringing together a collection of actors to coordinate their work and ensuring that the outcome promotes GCG. Moreover, uncoordinated autonomous actions taken by some stakeholder groups could shift risk to others if not integrating the needs of the wider community.



Resistance to domestic governance might arise from a conflict of interest between GCG goals and domestic actors arises. Cutting emissions depend heavily on economic activities; thereby, GCG based on domestic governance endows domestic actors with the potential to exert structural pressure on policymakers. Emission reductions are closely linked to economic activities in major industries, which influences energy-intensive industries and raises energy prices.

What will motivate local actors is the potential of changing their existing business model based on a new functional Socioeconomic system. What will derive energy transition is market forces which will be shaped by a functional Socioeconomic system. The core of establishing this system is the collective efforts of domestic actors in all nations.

National governments have started to change their initiatives to better address domestic climate change governance. This is illustrated in the following picture.

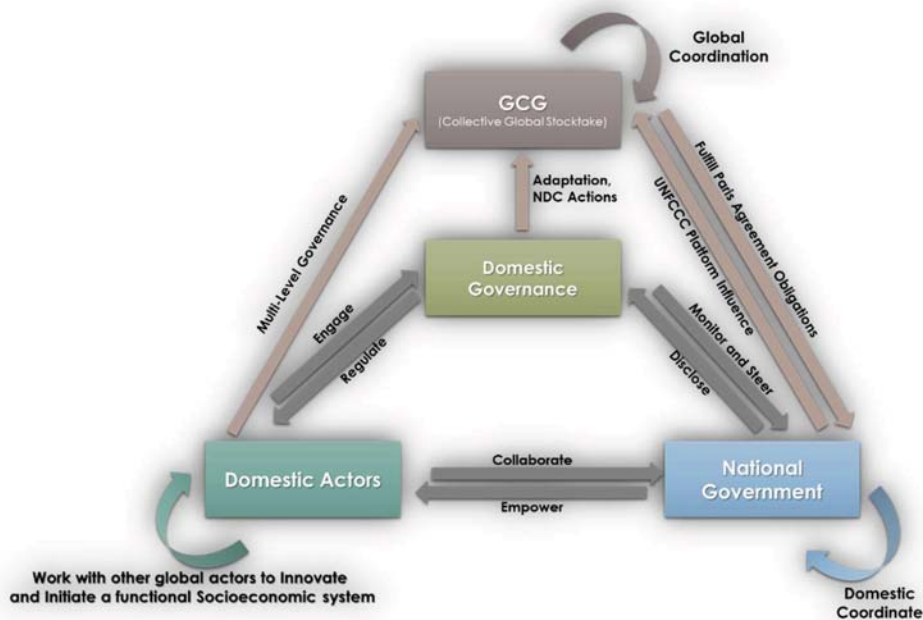


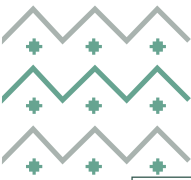
FIGURE 1: THE LINKAGES BETWEEN DOMESTIC ACTORS AND GLOBAL CLIMATE GOVERNANCE: SOURCE: AUTHUR

## RESEARCH METHODOLOGY

The methodology is to review multidisciplinary literature to consolidate research to answer the question about the effectiveness of current GCG to forge a global functional Socioeconomic system that is able to factor in local circumstances.

## EXPECTED OUTCOME

The success of the Current GCG hinges on the assumption that domestic actors will act responsibly. The aim of this paper has been modest: to redirect academic and policy attention to the coming issue between GCG and climate change domestic governance and to the options for enhancing coordination. I will postulate that motivating domestic actors to act vulnerably is perplexing. The right mix between market forces, technological innovation, and governmental policies.



***CIFAL CENTER METHODOLOGY IN LEVERAGING THE AWARENESS TOWARDS IMPROVING THE ENERGY SUSTAINABILITY***

Aiman Albarakati, Majmaah University

**Overview**

Unless they are aware of the problems, people and entire organisations are unlikely to actively conserve energy or operate in an environmentally beneficial manner. Energy awareness is the understanding of the nature, composition, and qualities of energy as well as the comprehension of methods for using less energy. The lone person also needs to be motivated to work effectively and understand the value of energy conservation. According to Partanen-Hertell et al., energy and environmental awareness is a combination of motivation, knowledge, and skills. As a result, the Cifal Center and the Saudi government have launched several initiatives to increase Saudi residents' awareness of energy sustainability through surveys, polls, commercials, and question-and-answer sessions in the media. One of the world's top energy consumers is Saudi Arabia. There is a significant amount of energy waste because it is the first-largest producer of oil in the world and because energy costs are so cheap. More over a quarter of Saudi Arabia's energy production is consumed. Energy consumption in 2012 was 3.29 times higher than total primary energy production. In Saudi Arabia, the annual growth rate of total energy consumption from 2000 to 2012 was 5.6% (2.2% globally). CIFAL is an important asset in the long-term efforts of the United Nations to achieve sustainability in the Saudi Arabian energy sector. The most recent energy efficiency initiatives from Cifal and Saudi Arabia are consistent with both the nation's Vision 2030 objectives for a diverse and sustainable economy and the UN's Sustainable Development Aims (SDGs). The Saudi Arabian administration is aware of how crucial it is to plan efficiently and sustainably for both energy production and consumption. In the past 10 years, with the help of Cifal and other organisations, the Kingdom revised its regulations for the Saudi Electricity Company (SEC) and established the Saudi Energy Efficiency Center (SEEC) to promote energy efficiency and sustainable energy awareness throughout all sectors. The SEC's Smart Metering Project is another another significant step in the direction of energy efficiency.

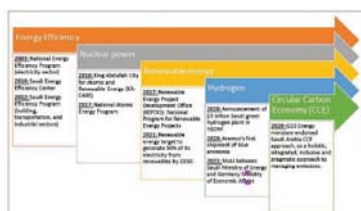


Figure 01: Saudi's energy transition journey.



Figure 02 : Renewable energy installed capacity in Ksa 2011-2020. Source: IRENA 2021

The SEC's Smart Metering Project, implemented to enhance electrical usage, billing, and monitoring for homes and businesses and help the nation move closer to achieving its Vision 2030 digitization goals, is another significant step in the direction of energy efficiency. As the foundation for future change, Wong contends that the first step in promoting energy conservation is increasing awareness of it. According to Cifal and a plethora of other studies, raising employee energy awareness is the most effective strategy to promote energy conservation activities. Although Saudi Arabians favour technological solutions, Cifal and its team continued to value human-centered strategies. Teams frequently lack knowledge about the effectiveness of awareness campaigns, which hinders workers from being aware of the issue and, ultimately, one of the causes of energy inefficiency. The main goal is to incorporate sustainability into Saudi Arabia's energy sector, which has been made feasible by the CIFAL Center's continued emphasis on this issue and the requirement for energy education and awareness programmes.

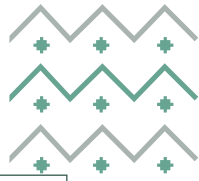
**Methods**

For the purpose of gathering and analysing the data, the study has employed a hybrid methodology that combines descriptive and quantitative methodologies. To discover and identify the sample population, a snowball sampling technique was employed. Data from the participants was gathered through an online questionnaire-based survey. After consulting the pertinent literature, a standard questionnaire with inquiries pertaining to the objectives was created. On the online survey platform Question Pro ([www.questionpro.com](http://www.questionpro.com)), the questionnaire was posted and remained live for three months between January and March. Online polls are quicker, less expensive, and more private information is

Energy and the Environment







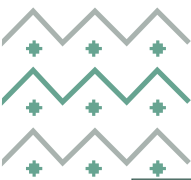
protected. Consequently, the study chose the online survey approach. After the sample participants were selected, the survey link was distributed via email and social media. Additionally, it was requested of the beneficiaries to let their nearby businesses know about the link. At the time the survey link was shut down at the end of March, 310 people had consented to participate in the survey and completed the shared questionnaire. The main goal of CIFAL's programmes in Saudi Arabia is to build and expand human capacity so that people can respond to development concerns like energy sustainability more effectively. CIFAL Centers use a facilitative approach with the following goals: Facilitate the transfer of knowledge, experiences, and best practises among government officials, business executives, and leaders of civil society (particularly) to 1) Enhancing the ability to carry out energy sustainability duties with effectiveness. 2) Promote collaboration and the formation of multi-stakeholder alliances for sustainable energy. 3) Offer networking opportunities that encourage city-to-city cooperation. 4) Participate in the creation of regional and governmental energy conservation plans.

## Results

79.2% of respondents to an online poll conducted as part of an awareness campaign in Dammam City had heard of and were familiar with sustainable energy sources, compared to 20.8% who had not. The results showed that the respondents were worried about sustainable energy, had information about it, were aware of it, and wanted to make sure that Saudi Arabians understood its importance. Also revealed by the study's findings was that 71.6% of respondents decided to produce their own electricity using sustainable energy. According to these findings, people are ready to use sustainable energy in their daily life. Because they understood the benefits, the majority of respondents in the current study were in favour of using sustainable energy sources instead of conventional ones. 28.4% of respondents chose fossil fuels as their energy source, despite the fact that most respondents preferred using sustainable energy. These findings suggest that interested parties should implement suitable policies to increase public knowledge of sustainable energy. Early education is essential for helping children comprehend the need for sustainable energy and for guaranteeing the sustainability of environmental protection for a brighter future. A whopping 97.2% of those polled said sustainable energy would be beneficial, especially in terms of protecting the environment. 2.8% of respondents, however, didn't think sustainable energy would be advantageous, particularly in terms of environmental preservation. Because they thought that the KSA was moving toward renewable energy, which would help to reduce global warming and carbon emissions, respondents in Dammam City were aware of the benefits of sustainable energy. Regarding its intention to use renewable energy as part of Saudi Vision 2030, the KSA government's strategy was noted in the questionnaire. The government's initiatives to advance the use of renewable energy were unknown to 70.3% of study participants. Information was gathered via friends, teachers, ads, and events. The government might use these discoveries, in Cifal's opinion, to promote renewable energy, which is viewed as an inexhaustible supply of energy and is also environmentally friendly. The Kingdom of Saudi Arabia (KSA), the world's largest oil user in 2018, relied on oil for 42.2% of its electricity, with natural gas providing the rest 57.8%. According to the International Renewable/Sustainable Energy Agency, the nation had only installed 397 MW of renewable energy by the end of 2019, 394 MW of which came from solar power.

## Conclusions

This study was conducted to determine the Saudi Arabian population's environmental knowledge of renewable energy sources and to identify practical methods for raising awareness of sustainable energy sources among the general public. The findings showed that the survey participants knew a reasonable bit about renewable energy. Due to the high cost of conventional energy sources including wind, solar, biogas, and geothermal energy, many respondents were interested in adopting sustainable energy; however, middle class and low-income families could not afford it. If technology was affordable, more people would be able to buy it, which would help the government achieve the goals outlined in Vision 2030. The study's findings also point to a lack of public understanding of the government's sustainable energy plan, either as a result of low visibility or because people have decided to disregard it. The findings show that the government must work decisively to increase public awareness through social media platforms, which are widely used by the populace in general and youth in particular. The government might use marketing strategies to emphasise the benefits and challenges of renewable energy. Through public activities and events, the utilisation of the newest renewable technologies and cost-cutting techniques to prevent environmental pollution might be demonstrated. In order to ensure that the goals of Vision 2030 regarding the use of sustainable energy are reached, the government and Cifal centre KSA must look into the idea of raising environmental public awareness of sustainable energy. The findings of this kind of research will provide a comprehensive picture of how Saudi Arabians view, accept, and feel about renewable energy. Future studies should broaden their scope in order to more accurately assess how much of the public in the KSA is aware of and concerned about sustainable energy.



## References

About the CIFAL Global Network. [unitar.org](http://unitar.org)

<https://ussaudi.org/sustainability-in-saudi-arabia-recent-energy-efficiency-initiatives/>

<https://www.climate-policy-watcher.org/energy-consumption/energy-awareness-and-environmental-sustainability.html#:~:text=In%20case%20of%20energy%20awareness%2C%20it%20means%20that,conservation%20and%20should%20be%20motivated%20to%20act%20accordingly.>

A. Qazi, et al., Towards sustainable energy: a systematic review of renewable energy sources, technologies, and public opinions, *IEEE Access* 7 (2019) 63837e63851, <https://doi.org/10.1109/access.2019.2906402>.

M. Akbary, V. Sayad, Analysis of climate change studies in Iran, *Phys. Geogr Res Q* 53 (1) (2021) 37e74, <https://doi.org/10.22059/jphgr.2021.301111.1007528>.

C. Henry, et al., How will renewable energy development goals affect energy poverty in Guatemala? *Energy Econ.* 104 (2021), 105665 <https://doi.org/10.1016/j.eneco.2021.105665>. (Accessed 2 March 2022).

S. Oluoch, P. Lal, A. Susaeta, N. Vedwan, Assessment of public awareness, acceptance and attitudes towards renewable energy in Kenya, *Scientific African* 9 (2020), e00512, <https://doi.org/10.1016/j.sciaf.2020.e00512>.

G. Guven, Y. Sulun, Pre-service teachers' knowledge and awareness about renewable energy, *Renew. Sustain. Energy Rev.* 80 (2017) 663e668, <https://doi.org/10.1016/j.rser.2017.05.286>.

BP Statistical Review of World Energy June 2013. Available online: <http://www.bp.com/statisticalreview> (accessed on 12 May 2014).

Alyousef, Y.; Abu-ebid, M. Energy Efficiency Initiatives for Saudi Arabia on Supply and Demand Sides, *Energy Efficiency—A Bridge to Low Carbon Economy*; Morvaj, Z., Ed.; InTech: Rijeca, Croatia, 2012.

Alshehri, A.; Hussain, A.; Mobarak, Y. Energy-conversion measures in the industries of Saudi Arabia and development of methodology for certification of energy personnel in the Kingdom. *Energy Policy* 2014, 64, 203–208

S. Basria, S.U. Zakariaa, S.K. Kamarudina, Review on alternative energy education in Malaysia, *J. Kejuruteraan.* 33 (3) (2021) 461e472.

A. Almulhim, Y. Aina, Understanding household water-use behavior and consumption patterns during COVID-19 lockdown in Saudi Arabia, *Water* 14(3) (2022) 314e384, <https://doi.org/10.3390/w14030314>

C. Parker, et al., *Snowball Sampling*, SAGE Publications Limited, 2020.

K. Seetharaman, N. Moorthy, S. Patwa, Saravanan, Y. Gupta, Breaking barriers in deployment of renewable energy, *Heliyon* 5 (1) (2019), e01166, <https://doi.org/10.1016/j.heliyon.2019.e01166>.

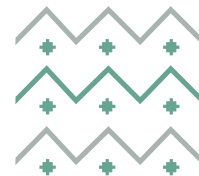
H. Elmustapha, T. Hoppe, H. Bressers, Consumer renewable energy technology adoption decision-making: comparing models on perceived attributes and attitudinal constructs in the case of solar water heaters in Lebanon, *J. Clean.Prod.* 172 (2018) 347e357.

G. Bhaumik, The Climate and Seasons in Saudi Arabia”, *Expatica.com*, 2021 [Online]. Available at: <https://www.expatica.com/sa/moving/about/theclimate-and-seasons-in-saudi-arabia-71019/> (Accessed 5 November 2021).

I. Mosly, A. Makki, Current status and willingness to adopt renewable energy technologies in Saudi Arabia, *Sustainability* 10 (11) (2018) 4269, <https://doi.org/10.3390/su10114269>

L. Collins, ‘We Will Be Pioneering’: Saudi Arabia Reveals 50% Renewables Goal by 2030, but Is that Realistic?’, *Recharge*, 2021 [Online]. Available at: <https://www.rechargenews.com/energy-transition/we-will-be-pioneering-saudi-arabia-reveals-50-renewables-goal-by-2030-but-is-that-realistic-2-1-954094> (Accessed 5 November 2021).





## Efficiency of zinc oxide nanorods (ZnO NRs) in Real Produced Water Treatment

Fatema Al Hajri, Oman Hydrogen Centre, German University Technology, Sultanate of Oman +968 22061197, [Fatema.alhajri@gutech.edu.om](mailto:Fatema.alhajri@gutech.edu.om)  
 Sausan Al Riyami, Oman Hydrogen Centre, German University Technology, Sultanate of Oman, +9689 22061196, [Sausan.alriyami@gutech.edu.om](mailto:Sausan.alriyami@gutech.edu.om)  
 Mohammed Al Abri, Nanotechnology Research Center, Sultan Qaboos University, Sultanate of Oman, +968 2414 3763, [alabri@squ.edu.om](mailto:alabri@squ.edu.om)

### Overview

Due to the rising global demand for fossil fuels for energy generation, the oil and gas industry remains the backbone of the worldwide economy. Petroleum exporting countries need to increase production to satisfy these growing demands<sup>(7)</sup>. However, the oil and gas reserves exploitation has not always been without environmental impacts, such as oil spills, damaged land, accidents, and fires, as well as incidences of air and water pollution. At the same time, one of the leading environmental concerns of oil production in the Sultanate of Oman is the enormous co-production of produced water. This wastewater stream contains a complex mixture of inorganic and organic compounds. It is considered the most significant toxic waste stream from the oil and gas industry<sup>(5),(6)</sup> and has become one of the main threats to oils and gas production companies. Sufficient treatment technologies are needed to bring these streams to a condition suitable for recycling, reuse, or discharge into the environment, as this wastewater is highly contaminated and linked with substantial health, safety, and environmental consequences<sup>(8)</sup>. Recently, nanotechnology-based water treatments emerged as potential treatment methods for non-conventional wastewater. They are inexpensive green technologies that do not require additional chemicals and do not produce secondary waste<sup>(9),(1)</sup>. Most of these techniques are based on photocatalytic degradation, which is a promising strategy as it can utilize a renewable source of energy such as solar energy. This technique depends on semiconductors that have the ability to mineralize organic matter into benign substances, such as carbon dioxide and water in the presence of light<sup>(3)</sup>. Developing efficient photocatalysts to degrade organic matter from produced water is vital from economic and social development viewpoints<sup>(10)</sup>. Even though there have recently been some major improvements, the degradation efficiency and reuse utilization are still low and cannot be used in real-world applications<sup>(4)</sup>. As illustrated by many studies the photocatalytic efficiency is significantly influenced by each stage of the photocatalytic process, including charge excitation, separation, transport, adsorption, and surface reaction of the semiconductor. Therefore, while applying photocatalysis in wastewater treatment some factors should be taken into account and properly tuned to enhance their efficiency, namely, the properties of water being treated, type and structure of semiconductors, reactor design and specifications, and light source and intensity.

### Methodology

This study investigates the efficiency of supported zinc oxide nanorods (ZnO NRs) in the photocatalytic treatment of produced water from an oil field in the Sultanate of Oman under natural solar irradiation. A detailed analysis has been attempted on the degradation of organic contaminants in produced water under solar irradiation in the presence of ZnO NRs that were synthesized and used as a photocatalyst. ZnO NRs were prepared using a microwave-assisted hydrothermal process. Firstly, microscope glass substrates were cleaned from contaminants and used as a substrate for ZnO NRs growth. Then, the seed layer was deposited on the glass substrate using spray coating. This was done by spraying 10 mM of zinc acetate on the previously cleaned substrate at a temperature of 350 °C. After that, the nanorods' growth was maintained under microwave irradiation by mixing an equimolar amount of 40 mM of zinc nitrate and 40 mM HMTA (hexamethylenetetramine). Finally, the prepared ZnO NRs were then annealed at 350 °C for one hour. The characteristics and properties of ZnO NRs were investigated using various techniques. On top of that, the crystallinity, phase nature, and lattice parameters were analyzed using X-ray diffraction (XRD, Rigaku MiniFlex 600, Japan). Photoluminescence Spectroscopy (PL, PerkinElmer, LS 55 fluorescence spectrometer, USA) was used to identify surface defects in the ZnO NRs. UV-Visible spectroscopy (PerkinElmer Lambda 12 UV-VIS spectrometer) was used to analyze the optical properties. A Scanning electron microscope (SEM, JSM-7600F, JEOL, Japan) was utilized to characterize the surface morphology and topography. The prepared ZnO NRs were used as a photocatalyst for the degradation of produced water under natural sunlight for 5 hours. The experiments were divided into two phases using different photocatalytic reactors (batch and continuous flow reactors). The photocatalytic degradation of produced water using ZnO NRs was determined using total organic carbon (TOC) analyzer.

### Results and Discussion

Microwave-assisted hydrothermal (MAH) synthesis has been used to synthesize the ZnO NRs on glass substrates. **Fig 1** demonstrates the XRD pattern of the synthesized ZnO NRs. The diffraction peaks in

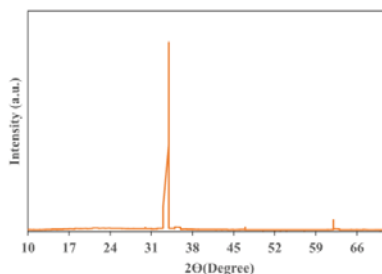


Fig 1: XRD pattern





(Fig. 1) are related to the hexagonal wurtzite crystal structure of ZnO. This data was in agreement with card no JCPDS 36-1451. The strongest diffraction peak was observed at  $34.3^\circ$  which implies that the nanorods have a preferential c-axis orientation that is perpendicular to the substrate. The SEM results (Fig 2) show a high yield of homogeneous and well aligned ZnO NRs grown on the glass substrate. Moreover, the PL curve (Fig 3) demonstrates different peaks at 3.102 eV, 2.949 eV, 2.822eV, 2.567 eV, and 2.354 eV that are related to ZnO point defects complexes that are related to violet, blue and green emissions. The presence of these defects was found to enhance the ZnO optical properties towards the visible region and therefore, make it an effective candidate for photocatalytic degradation under natural sunlight<sup>(5)</sup>. Moreover, the UV-visible spectrum of the as-prepared ZnO NRs shows broad/strong absorption at  $\sim 375$  nm as shown in (Fig 4). The estimated band gap of the prepared ZnO NRs is  $\sim 3.27$  eV according to the Tauc plot demonstrated in (Fig 4). The ZnO NRs were used to treat real produced water in a batch reactor under natural Sunlight. The preliminary results of the prepared ZnO NRs show that ZnO is an effective photocatalyst under solar irradiation. **Error! Reference source not found.** shows the percentage of degradation of the organic contents in the produced water. As it is clear from (Fig 5), the concentration of organics decreases from 100% to around 70% after 5 hours of light irradiation with a removal efficiency of 30% (as shown in the green column Fig 5). Additionally, the degradation of organics in the absence of ZnO shows around 7% degradation which demonstrates that sunlight alone has almost no effect on organic degradation. The findings will be discussed in detail in the poster.

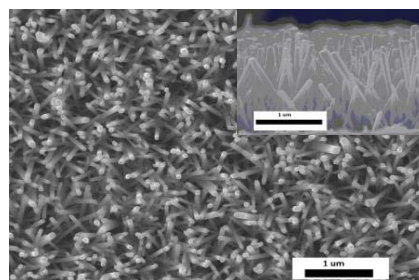


Fig 2: SEM micrograph (Top and cross-sectional view).

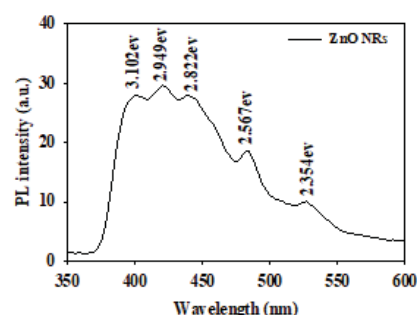


Fig 3: PL curve

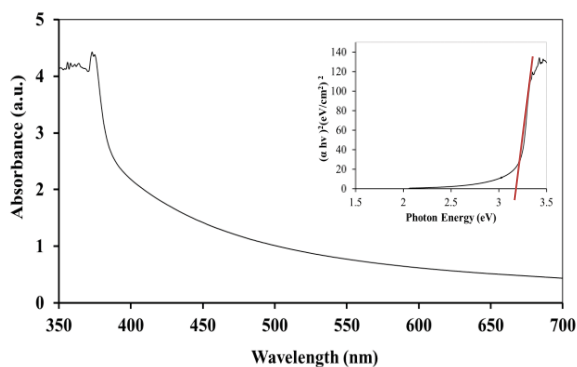


Fig 4: UV-Visible spectroscopy plot

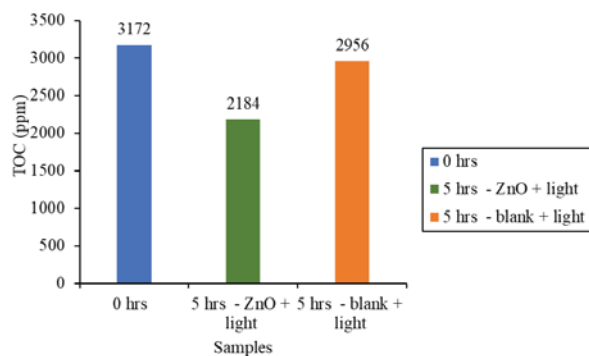


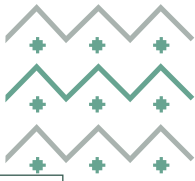
Fig 5: The Results of TOC of the prepared ZnO NRs in a batch system

## Conclusion

The current preliminary study reveals the high efficiency of ZnO NRs in organic pollutants degradation for produced water treatment. Organic matter degradation of  $>30\%$  was achieved under optimal conditions showing the high potential of photocatalysis in produced water treatment.

## References

1. Al-Ghouti, M. A., Al-Kaabi, M. A., Ashfaq, M. Y., & Da'na, D. A. (2019). Produced water characteristics, treatment and reuse: A review. *Journal of Water Process Engineering*, 28, 222-239.
2. Al-Sabahi, J., Bora, T., Claereboudt, M., Al-Abri, M., & Dutta, J. (2018). Visible light photocatalytic degradation of HPAM polymer in oil produced water using supported zinc oxide nanorods. *Chemical Engineering Journal*, 351, 56-64.
3. Alkhazraji, H. A., & Alatabe, M. J. (2021). Oil Recovery from Oilfield Produced Water Using Zinc Oxide Nano Particle as Catalyst in Batch and Continuous System. *Journal of Ecological Engineering*, 22(8), 278-286. <https://doi.org/10.12911/22998993/140281>



4. Anju, S., Yesodharan, S., & Yesodharan, E. (2012). Zinc oxide mediated sonophotocatalytic degradation of phenol in water. *Chemical Engineering Journal*, 189, 84-93.
5. Chen, L.-l., Zhai, B.-g., & Huang, Y. M. (2020). Rendering visible-light photocatalytic activity to undoped ZnO via intrinsic defects engineering. *Catalysts*, 10(10), 1163.
6. Igunnu, E. T., & Chen, G. Z. (2014). Produced water treatment technologies. *International journal of low-carbon technologies*, 9(3), 157-177.
7. Meng, S., Li, W., Li, Z., & Song, H. (2022). Non-thermal plasma assisted catalytic thiophene removal from fuel under different atmospheres. *Journal of Cleaner Production*, 133282.
8. Nestic, S., & Streletskaya, V. V. (2018). An integrated approach for produced water treatment and injection. *Георесурсы*, 20(1 (eng)), 25-31.
9. Nonato, T., Alves, A., Sens, M., & Dalsasso, R. (2018). Produced water from oil-A review of the main treatment technologies. *Journal of Environmental Chemistry and Toxicology*, 2(1), 23-27.
10. Ren, G., Han, H., Wang, Y., Liu, S., Zhao, J., Meng, X., & Li, Z. (2021). Recent advances of photocatalytic application in water treatment: a review. *Nanomaterials*, 11(7), 1804.







## What changed in the IPCC report before and after the Paris Agreement

Jinmi Kim, Korea University, +821030112973, jkim@ipcc-syr.org

### Overview

IPCC assesses peer reviewed scientific literature on climate change and response strategies to facilitate evidence-based climate policy decisions. The IPCC 5<sup>th</sup> Assessment (AR5) conducted from 2007 to 2015 served as the scientific basis for the Paris Agreement, which aims to limit the increase in global average temperature by 2 degrees Celcius and well below 1.5 degrees Celcius. In 2022, seven years after the Paris Agreement, the IPCC released the latest assessment (the 6<sup>th</sup> Assessment) reports and prepares a Synthesis Report. The purpose of this article is to identify the key differences in findings related to mitigation strategies between these two assessment reports and analyze the impact of the Paris Agreement on the evolution of response strategies to climate change.

### Methods

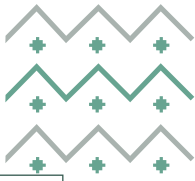
This article compares and analyses the IPCC report on mitigation released in 2014 and the report released in April 2022 from the perspective of evaluating the effectiveness of various policies and measures for mitigating climate change through emissions reductions.

- Timing of global peaking of greenhouse gas emissions: AR5 pointed out that global peaking of greenhouse gas emissions needs to take place as soon as 2020 to limit the temperature increase to 1.5 or 2 degrees C. The Sixth Assessment Report (AR6) pointed out that the peaking of global emissions should occur before 2025 for the same temperature goals as specified in AR5. We note that the AR5 conclusion was made available in 2014 and it in fact called for global emissions to peak within six years. This did not happen and emissions have kept rising past 2020. AR6, released in 2022, now said the peaking should occur in three years. There are two questions about this shifting of peaking time of emissions: what caused the missing of peaking in 2020?; and the delay in peaking would increase mitigation costs and did the AR6 result show the increase in mitigation costs? This paper will elaborate on the issues related to these two questions.
- Assumptions in scenarios: this paper will provide detailed comparisons of assumptions embedded in the emissions scenarios between AR5 and AR6 to give context to the conclusions related to both assessments.
- Cost: the top-down approach for estimating mitigation cost provides estimates of GDP loss that would result from mitigation activities. AR6 estimates a GDP loss of 1.3 – 2.7% in 2050. AR5 estimates were 1 – 4 % of GDP in 2030. This paper will analyze the difference between the two estimates. The bottom-up approach provides mitigation potential in the context of the costs of various technology options. Both AR6 and AR5 provide the outcome of bottom-up approaches. This paper will analyze what contributed to differences in the costs.

### Results

The challenge of climate mitigation is to avoid dangerous anthropogenic interference to the climate system in the context of sustainable development and poverty eradication. This requires a multi-dimensional understanding of the solution. The latest report contains assessments on the relationship between the demand side of socio-economic activity and emissions and mitigation potential. The report also has focus on urbanization and climate mitigation. It is expected that the knowledge of consumption patterns and behavioral aspects of consumption and investment decisions would inform the interface between policy design and implementation so that climate solutions will be broader based than the narrowly focused technology-driven pursuit.





## Conclusions

Since the adoption of the Paris Agreement, IPCC's assessment of climate solutions increased drastically. It is a remarkable departure from previous assessments where understanding of problems occupied primary space. I expect to present as conclusions the key impact of the Paris Agreement on the evolution of climate response strategies and how solution space changed between pre- and post- Paris Agreement.

## References

IPCC, 2014: *Climate Change 2014: Mitigation of Climate Change. Contribution of Working Group III to the Fifth Assessment Report of the Intergovernmental Panel on Climate Change* [Edenhofer, O., R. Pichs-Madruga, Y. Sokona, E. Farahani, S. Kadner, K. Seyboth, A. Adler, I. Baum, S. Brunner, P. Eickemeier, B. Kriemann, J. Savolainen, S. Schlömer, C. von Stechow, T. Zwickel and J.C. Minx (eds.)]. Cambridge University Press, Cambridge, United Kingdom and New York, NY, USA.

IPCC, 2022: *Climate Change 2022: Mitigation of Climate Change. Contribution of Working Group III to the Sixth Assessment Report of the Intergovernmental Panel on Climate Change* [P.R. Shukla, J. Skea, R. Slade, A. Al Khourdajie, R. van Diemen, D. McCollum, M. Pathak, S. Some, P. Vyas, R. Fradera, M. Belkacemi, A. Hasija, G. Lisboa, S. Luz, J. Malley, (eds.)]. Cambridge University Press, Cambridge, UK and New York, NY, USA. doi: 10.1017/9781009157926

Agreement, P. (2015, December). Paris agreement. In *Report of the Conference of the Parties to the United Nations Framework Convention on Climate Change (21st Session, 2015: Paris)*. Retrived December (Vol. 4, p. 2017). HeinOnline.





## Smart Cities Indicators, Human-Centric Development and the Impact on Energy Sustainability

Lama Yaseen, Research Lead, +966 53 900 9193, lama.yaseen@kapsarc.org  
Robert Marinescu-Muster, University of Twente, r.marinescu-muster@utwente.nl  
Nourah Al-Hosain, Research Associate, nourah.hosain@kapsarc.org

### Overview

Smart cities have become one of the most emerging urban development concepts in the past decade. A concept that encapsulates the initiatives of improving the "Quality of Life" of the citizens by addressing "Wicked" global issues such as Climate Change, Waste Management, and Energy Transition. In this paper, we will investigate three identified pillars of developing smart cities, *People*, *Technology*, and the *Environment*. The contribution of individuals in a community plays an essential role in sustainable urbanization. Leveraging advanced technological solutions such as Big Data and Artificial Intelligence (AI) can increase the efficiency of many aspects of urban life. We focus on these two pillars to create a system that preserves the *Environment* by utilizing the combination of the contribution of *People* and the capabilities of *Technology* to achieve sustainable energy use. We will analyze the underlying indicators of smart cities under the identified pillars and discuss some scenarios of current and emerging smart city development initiatives to draw insights and conclusions that address the identified pillars and how they intertwine.

### Methods

In this paper, we will explore the interrelation of the three identified pillars *People*, *Technology*, and the *Environment*. These pillars were identified in the context of this paper by the analysis of an amalgamation of the characteristics of what makes a smart city "smart." We will identify and analyze different perspectives as possible indicators of a citizen-centered smart city that focuses on human needs and sustainability. We propose a qualitative Thematic approach that will identify and analyze different perspectives and patterns as possible indicators of a citizen-centered smart city that focuses on human needs and sustainability. Our sources will include open-data sources, literature on existing or prospective smart cities, and other smart-city frameworks.

### Results

We will discuss and identify possible indicators that revolve around the pillars which could possibly act as a potential framework of the sustainable development of smart cities. The results will include a cascading relationship between the indicators and the pillars identified showing how each indicator is networked towards achieving sustainable urban development.

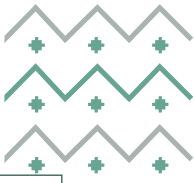
### Conclusions

To develop an inclusive, sustainable and resilient smart city, the role of citizens is of absolute importance. Leveraging the technologies and the capabilities of IoT, AI, and Big Data will help optimize the operations of various dimensions of the quality of living, such as health, energy efficiency, independence, and mobility. Understanding the needs of the people and developing the cities around their needs is a key factor in achieving quality of life in the smart city.

### References

- [1] OECD, (December, 2020) Measuring Smart cities performance; Do smart cities benefit everyone?.
- [2] Borsekova. K., Koróny. S., Vaňová. A., Vitálišová, K., (2018, March). Functionality Between the size and indicators of smart cities; A research challenge with policy implications, *Cities*, 78





[3] Sharifi, A., (2019, October). A critical review of selected smart city assessment tools and indicator sets, *Journal of Cleaner Production, Volume 233*

[4] Razmjoo. A., Gandomi. A., Mirjalili. M., Rezaei. M. (2022 September). The key role of clean energy and technology in smart cities development *Energy Strategy Reviews, 44*





## **MODELLING CLIMATE CHANGE IMPACT ON HYDROELECTRIC POWER AND ENERGY PRODUCTION**

Cem B. Avci, Bogazici University, Phone +90 212 359 64 10, E-mail: [avci@bogazici.edu.tr](mailto:avci@bogazici.edu.tr)  
Cem Tiranlar, Bogazici University, Phone +90 536 295 17 27, E-mail: [cemtiranlar@bogazici.edu.tr](mailto:cemtiranlar@bogazici.edu.tr)  
Irem Akcan, Bogazici University, Phone +90 534 315 48 18, E-mail: [akcanireni@bogazici.edu.tr](mailto:akcanireni@bogazici.edu.tr)  
Masume Atam, Bogazici University, Phone +90 553 953 87 73, E-mail: [atammasu@bogazici.edu.tr](mailto:atammasu@bogazici.edu.tr)

### **Overview**

There is a strong interest in decreasing the share of fossil fuels based electricity generation and replacing it with renewable energy based electricity production in Turkey. Turkey has signed the Paris Agreement in 2016 and pledged to decrease the greenhouse gas generation through the development of clean energy sources (Climate Change Action Plan, 2021). Hydroelectricity is a major source of electricity in Turkey, due to its mountainous landscape and many with over 700 hydropower plants having been built, and hydroelectricity making up about 30% of the country's electricity generating capacity. In 2021, 56 terawatt-hours of hydroelectricity was generated, which was 15% of Turkey's total electrical generation.

The U.N. Intergovernmental Panel on Climate Change (IPCC, 2021) reported that due to accelerating trends in temperatures, dehydration, and rising sea levels Turkey is likely to experience more frequent and more severe weather conditions throughout the year. By 2050 temperatures are predicted to increase by 2.5° Celsius in the east and inland of Turkey, and by 1.5° Celsius on the coasts. Temperatures exceeding 40° Celsius are expected in the summer and extended periods. Additionally, Turkey's annual precipitation is expected to decrease by about 10% — especially in the west and along the Mediterranean coast — by 2050. This will result in increased water scarcity and periodic drought, problems that will be exacerbated by glacial retreat and decreased snowfall in the mountains, from which half of the country's water is derived. Although Turkey's energy strategy may change in the future, due to climate change causing more frequent droughts, hydropower is predicted to remain important for load balancing with solar and wind power.

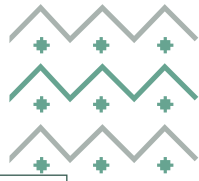
Climate change modelling coupled with watershed hydrological predictions is an important tool for predicting the future energy potential of the existing hydroelectric power plants. Future energy production planning can be achieved by realistic climate models should be made for hydroelectric power plants and their basins and future forecasts should be analyzed. These existing investments can be evaluated and the long-term contributions of these power plants to the climate change can be estimated. A case study for a hydroelectric power plant production located in the northern part of Turkey was assessed. The power plant with a total capacity of 241.098 GWh/year over 10,758.4 km<sup>2</sup> catchment was investigated to assess the potential impacts of climate change.

### **Methods**

The SWAT model is a physically based hydrological simulation tool developed to analyze soil and water interactions, sediment and nutrient dynamics. By using the SWAT model, many hydrological processes in a basin such as groundwater flow, evaporation and percolation can be analyzed (Neitsch et al., 2011). A basin model was developed using Digital Elevation Model (DEM) and river data. The main basin was divided into sub-basins by a certain threshold value. Land use data, soil properties and slope information of the region are introduced to the model, creating hydrological response units (HRUs) that allow for more detailed analysis. Model calibration was performed manually. DEM (15 x 15 m resolution), soil properties (47 different soil classes), land use data (22 different land use classes) and meteorological data with 11 stations were used for model setup. In order to perform the calibration, results of the baseline model simulation and the data obtained from the flow observation stations were compared. A detailed literature search was conducted to determine the streamflow calibration parameters, and 5 parameters were selected as flow curve number (CN2), saturated hydraulic conductivity (Sol\_K), available water capacity layer depth (Sol\_AWC), baseflow alpha factor (Alpha\_BF), groundwater recharge coefficient (GW\_rech). The model was calibrated for the years 2020-2021 with the help of selected parameters. After the calibration was completed, the model simulation results were found to be in agreement with the measurement data, and the average flows were consistent. According to the measurement data, the annual average flow at the basin outlet was 50.6 m<sup>3</sup>/s and 34.2 m<sup>3</sup>/s for the years 2020 and 2021, respectively. As a result of the baseline model simulation, these are 50.6 m<sup>3</sup>/s and 34.8 m<sup>3</sup>/s, respectively.







In this study, low resolution data of MPI-ESM-MR (Giorgetta et al., 2013) developed by Max Planck Meteorology Institute in Germany and HadGEM2-ES (Collins et al., 2008) global climate models developed by Met Office Hadley Center in England was dynamically reduced to 50 km and then to 10 km high resolution by using the RegCM4.4 regional climate model. The model outputs were obtained by averaging the two model results. In the study, precipitation, air temperature, relative humidity and wind speed were used as climate variables. The temporal resolution of these variables is 3 hours. The climate change scenario was prepared after the baseline model was created, in order to evaluate the hydrological conditions of the basin under the influence of climate change. The climate change scenario covers the years 2021-2050. In order to establish a relationship between climate change scenario precipitation forecasts and actual precipitation data, and to obtain a finer-scale precipitation forecast, 2021 data of actual and scenario precipitation were taken into account. Climate change precipitation forecasts for 2021 and actual precipitation data are matched monthly using certain coefficients. This process was carried out separately for each station. Precipitation forecasts until 2050 were then corrected by multiplying them with the coefficients used for 2021.

## Results

The data obtained by adjusting the climate change forecasts were used in the calibrated baseline model (without changing the calibration parameters), and the model was run for the years 2022-2050. When the climate change simulation results are examined; The annual average flow is 37.3 m<sup>3</sup>/s in 2022, this value rises to 41.8 m<sup>3</sup>/s in 2023 with an increase of approximately 12%. There are small decreases and increases from 2024 to 2027, but the flow values decrease to 13.08 m<sup>3</sup>/s and 19.14 m<sup>3</sup>/s in 2028 and 2029, respectively. In 2030, the flow value reaches 35.47 m<sup>3</sup>/s and there are small increases and decreases until 2038. Flow values decrease to 7.23 m<sup>3</sup>/s and 17.52 m<sup>3</sup>/s in 2038 and 2039, then increase again until 2050 and reach 37.9 m<sup>3</sup>/s in 2050. The yearly variations were assessed for the hydroelectric power plants within the watershed.

## Conclusions

Hydroelectricity is a major source of electricity in Turkey, due to its mountainous landscape and many rivers. making up about 30% of the country's electricity generating capacity. Climate change is expected to result in rising temperatures, dehydration, and rising sea levels Turkey and also likely to experience more frequent and more severe weather conditions throughout the year. Watershed modelling coupled with climate change predictions allows for assessing the future energy potential of watersheds where existing hydroelectric power plants are situated. In this study, the climate change were predicted in a watershed basin located in the northeastern part of the country and watershed modelling was conducted to assess the future rainfall runoff event and assess the hydroelectric power of the existing plants.

## References

Masson-Delmotte, V., Zhai, P., Pörtner, H. O., Roberts, D., Skea, J., Shukla, P. R., ... & Waterfield, T. (2018). Global warming of 1.5 C. An IPCC Special Report on the impacts of global warming of, 1(5).

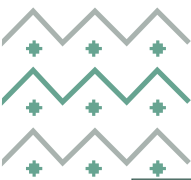
Pierce, D. W., Barnett, T. P., Santer, B. D., & Gleckler, P. J. (2009). Selecting global climate models for regional climate change studies. *Proceedings of the National Academy of Sciences*, 106(21), 8441-8446.

Demircan, M., Gürkan, H., Eskioglu, O., Arabacı, H., & Coşkun, M. (2017). Climate change projections for Turkey: three models and two scenarios. *Turkish Journal of Water Science and Management*, 1(1), 22-43.

2021 Yılı Elektrik Üretim-Tüketim Raporu [2021 Yearly Electricity Production-Consumption Reports (tab "Kaynaklara Göre" which means "by source". From the totals column divide "hydro" by "gross generation")] (2021 Yılı Elektrik Üretim-Tüketim Raporu.xlsx). Turkish Electricity Transmission Corporation (Technical report). Archived from the original on 2022-02-18. Retrieved 2022-02-18.

"Turkey Energy Outlook". Sabanci University Istanbul International Center for Energy and Climate. Archived from the original on 2021-10-06. Retrieved 2021-12-30





## *Beyond clean energy technological fixes: A critical assessment on the hydrogen partnerships between Germany and Arab Gulf states*

Dr. Tobias Zumbraegel, University of Hamburg & Center for Applied Research in Partnership with the Orient (CARPO), Bonn

### Overview

Climate change is considered to be one of the 'grand challenges' of the 21<sup>st</sup> century. A special role is dedicated to the Arab Gulf states. While they are highly dependent on selling fossil fuels and pressured to change this hydrocarbon-based path dependency, they are also well-equipped to undertake their climate transitions. Recently announced net-zero targets by countries such as Saudi Arabia, the United Arab Emirates or Bahrain appear promising and could be an appealing example to other nations in the region. However, it needs to be seen whether these states are able to comply to their self-given goals. In fact, the recent climate announcements were and still are, as we argue in this policy paper, driven by a techno-optimist vision and a need to protect and maintain economic and political power in a decarbonized world. I take the approach of 'technological fixes' as conceptual springboard to show how it undermines the plausibility of deep decarbonization in the region.

In order to achieve their deep decarbonization targets and maintain their economic and political power in a carbon-constrained world, Gulf states rely heavily on technology and innovation. Pursuing cutting-edge technology and innovation have always been important for the Gulf states but, over the last decade, sustainable technology and green solutions have been prioritized and gradually dovetailed with other existing industrial areas and structures. Two key areas are of utmost importance in the ecological modernization approach of the Gulf states (Reiche 2010): On the one hand, diversifying energy sources (renewable energy such as solar, wind and hydropower but also atomic power) and, on the other hand, decarbonization efforts (above all Carbon Capture, Utilization and Storage, CCUS). In this regard, environmental sustainability has emerged as a new 'playground' to enhance partnerships with other countries and foster technological buy-in. Transfer of innovation and technology is almost exclusively undertaken unilaterally with foreign nations or consultancy companies from industrialized regions that are collaborating with local companies and businesses. Transfer of innovation and technology is almost exclusively undertaken unilaterally with foreign nations or consultancy companies from industrialized regions that are collaborating with local companies and businesses.

Over the last two years, hydrogen has been presented as the new 'technological fix'. Especially, green and blue hydrogen is seen as the "holy grail of decarbonization" and "part of a long-term hedging strategy" for a time when the age of fossil fuels is over (Sez nec and Mosis 2020). Governments in Oman, Saudi Arabia and the United Arab Emirates have all announced ambitious projects to produce hydrogen in large amounts in the near future. Meanwhile, the German government is very keen on this technology in order to achieve its net-zero targets. Hydrogen is seen as an important element for electrifying key sectors such as aviation, shipping and heavy-duty transport, when renewables cannot match the capacity. Consequently, hydrogen diplomacy have become a new key element between Germany and some Arab Gulf states. In the scope of the German-Saudi Energy Dialogue in 2021, both countries signed a memorandum of understanding towards a closer hydrogen partnership. It is planned that Germany provides the technology for hydrogen projects in Saudi Arabia and receives green hydrogen exports from the kingdom. A further cornerston was the establishment of a German-Saudi hydrogen diplomacy office in Riyadh. At the same time, Germany also signed a declaration of intent to establish an Emirati-German Hydrogen Task Force in November 2021. This paper takes a critical perspective on these late developments and argues that there are still uncertainties and open questions that should be solved.

This article takes an historical analysis on discourses of technological fix and ecological modernization to discuss the Gulf monarchies' approach to climate change. It uses the example of hydrogen infrastructure and diplomacy to critical asses such a techno-optimistic perspective, which often misses to address other social, ecological and economic dimensions.

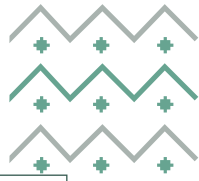
### Methods

This research includes qualitative methods such as ethnographic observation from various trips to the region including, ethnographic action research and Conversations with stakeholders at global and regional governance-related events. It further includes textual analysis based on secondary sources.

### Results

While policy makers in Germany and some Arab Gulf states are equally perceive hydrogen as the new solution there are unresolved questions. **First**, despite recent promises and targets to produce large quantities of hydrogen (green and blue), hydrogen technology is years away from becoming a global commodity (Dourian 2021). This is mainly





because it is currently too costly and energy-intensive. **Second**, there are doubts over the availability of the renewable energy and water resources required to produce green hydrogen. Until today, the installed renewable energy capacity of the Arab Gulf states is far beyond their self-given targets. By 2020, the total share of Renewables in the Energy Mix was very low with 0.1% in Bahrain, 0.5% in Kuwait, 1.3% in Oman, 0.3% in Qatar, 0.5% in Saudi Arabia and 7.3% in the UAE (Al-Sarihi and Mansouri 2022). Even if considering that especially countries like Saudi Arabia and the UAE might scale up their capacities within a short period of time, they need even more renewable energy when they want to use large quantities of it to export green hydrogen. Additionally, it is barely discussed, where the large amounts of water shall come from that are needed to produce green hydrogen. Relying on desalination, which most countries almost exclusively do, creates new ecological problems: For instance growing brine discharge leads to further salinisation of the sea (and ultimately also the soil), which, in turn, demands more highly energy-intensive desalination plants. Furthermore, growing rise in temperature in the Persian waterway also stimulates the growth of "harmful algal blooms that can block desalination plants and coastal industrial cooling systems" (Tolley 2021).

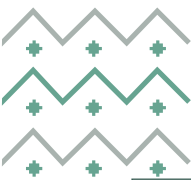
**Third**, supposed ecological risks have not been taken into account in this new hydrogen hype between the West and the Gulf. According to recent studies, there are indirect warming impacts as the oxidization of hydrogen in the atmosphere leads to increasing concentrations of greenhouse gases. It is estimated that hydrogen emissions (H<sub>2</sub>) could be "200 times that of carbon dioxide and larger than that of methane" (Ocko and Hamburg 2022, 9350). With regard to blue hydrogen, new, allegedly promising technology such as CCUS are questionably as they consume additional energy, leading to more emissions (Theeyattuparampil et al. 2013). CCUS combined with enhanced oil recovery, where gas or other chemicals are reinjected to extract more crude oil, creates more emissions and leads to potential soil erosions, toxicity, eutrophication, and acidification (Roefs et al. 2019). In terms of blue hydrogen, additional amounts of carbon dioxide (CO<sub>2</sub>) and methane (CH<sub>4</sub>) can escape through leakages, venting and purging across the value chain (Ocko and Hamburg 2022).

## Conclusions

Investing in hydrogen infrastructure and engaging in hydrogen diplomacy have been a new key element between Germany and some Arab Gulf states. However, there are many open questions regarding this hydrogen partnerships in terms of commercial feasibility, capacities and unintended ecological risks. This paper argues that policymakers in Germany and the Arab Gulf states need to pay more attention to these unresolved issues before engaging in this 'enthusiasm' of hydrogen as new technological fix towards a climate-sensitive energy transition. If not, hydrogen, will remain a distant and unlikely prospect.

## References

- Ansari, Dawud (2022): The Hydrogen Ambitions of the Gulf States. Achieving Economic Diversification while Maintaining Power, *SWP Comment* 44. Retrieved from: <https://www.swp-berlin.org/publikation/the-hydrogen-ambitions-of-the-gulf-states>
- Al-Sarihi, Aisha, and Noura Mansouri (2022): Renewable Energy Development in the Gulf Cooperation Council Countries: Status, Barriers, and Policy Options. *Energies* 15 (5): 1923.
- Dourian, Kate (2021): *Gulf countries gear Up for a net-zero world*. AGSIW Issue Paper 5. Retrieved from <https://agsiw.org/gulf-countries-gear-up-for-a-net-zero-world/>
- Ocko, Ilissa and Hamburg, Steven, P. (2022): Climate consequences of hydrogen emissions, *Atmospheric Chemistry and Physics* 22, 9349-9368, DOI: <https://doi.org/10.5194/acp-22-9349-2022>
- Reiche, Danyel (2010): Energy Policies of Gulf Cooperation Council (GCC) countries — possibilities and limitations of ecological modernization in rentier states. *Energy Policy* 38, 2395-2403.
- Roefs, Pieter, Moretti, Michele, Welkenhuysen, Kris, Piessens, Kris, & Comperollea, Tine (2019): CO<sub>2</sub>-enhanced oil recovery and CO<sub>2</sub> capture and storage: An environmental economic trade-off analysis. *Journal of Environmental Management* 239, 167-177. <https://doi.org/10.1016/j.jenvman.2019.03.007>
- Seznec, Jean-François & Mosis, Samer (2020): *The ACWA power-air products joint venture for green hydrogen: A new Saudi Energy policy?* Atlantic Council. Retrieved from <https://www.atlanticcouncil.org/blogs/energysource/the-acwa-power-air-products-joint-venture-for-green-hydrogen-a-new-saudi-energy-policy/>
- Theeyattuparampil, V., Zarzour, O., Koukouzas, N., Vidican, G., al-Saleh, Y., & Katsimpardi, I. (2013). Carbon capture and storage. State of play, challenges and opportunities for the GCC countries. *International Journal of Energy Sector Management*, 7(2), 223-242.
- Tolley, G. (2021, September 21). Gulf waters already changing 'dramatically' due to global warming, research finds. *The National*. <https://www.thenationalnews.com/uae/environment/2021/09/29/gulf-waters-already-changing-dramatically-due-to-global-warming-research-finds/>



**[ASSESSING THE PERFORMANCE DIMENSIONS OF HYDROGEN SUPPLY CHAIN PATHWAYS USING LIFE CYCLE SUSTAINABILITY ANALYSIS (LCSA) AND NETWORK ANALYTICS FOR THE HYDROCARBON INDUSTRY'S ENERGY TRANSITION]**

[Camilo Fernando, University of Aberdeen, UK, +447909555589, c.p.fernando19@gmail.com]

**Overview**

This paper aims to propose a futuristic sustainable hydrogen supply chain model for the hydrocarbon industry and evaluate its performance parameters in the environmental, social, and economic dimensions utilising network analytics. With increasing global calls towards de-carbonization and net-carbon neutrality by 2050, there is a serious drive towards finding alternate low-carbon energy sources in the energy industry. The 'Decarbonization Revolution' has driven Reliance Industries Limited (RIL) India towards creating a sustainable clean energy supply chain and making the company net carbon neutral by 2035 (Reliance Industries Limited, 2022a). Hydrogen, being not only the cleanest form of fuel but also a potential energy carrier, has been gaining momentum as an alternative to fossil fuels across world governments, industries, and international agencies (IEA, 2019). The "Hydrogen Value Chain", both as a fuel and an energy carrier, is examined using network analytics tools to propose a sustainable hydrogen supply chain for the hydrocarbon division of RIL, through the lens of the triple bottom line concept.

**Methods**

To understand how RIL caters to the hydrocarbon markets, its current business model is analysed using the business model canvas, while viewed through the lens of the canvas' nine inter-linked supply chain building blocks (Osterwalder et al., 2011), which are graphically visualised using the network analysis tool, Gephi.

Next, a detailed literature review is performed that involves two sections. Firstly, the use of hydrogen in the energy industry is briefly discussed, and Gephi is used to fully understand and observe the value chain of hydrogen and its global supply chain. This is done to obtain insights into the energy transition possibilities where RIL can effectively contribute and integrate into its own supply chain. Secondly, a study on sustainability and performance dimensions using the concept of life cycle sustainability analysis (LCSA) was performed for designing a sustainable hydrogen supply chain network (HSCN) considering environmental, economic, and social aspects at every stage in the overall supply chain.

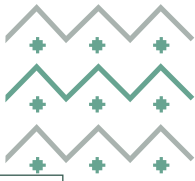
The technical platform for this paper is developed in two stages. First, an innovative business model for RIL is developed that critically evaluates areas where RIL can integrate into the hydrogen supply chain. The network analytic tool, Gephi, is used to show this integration into the hydrogen production focus points. This is followed by an attempt to categorise the environmental, economic, and social impacts of each potential option for RIL, using the LCSA framework discussed in the literature review. For this step, critical ranking parameters are provided on a scale from 1 to 6 (Ciroth et al., 2011) to generate a table highlighting the segment's risks for every proposed RIL's hydrogen integration options.

**Results**

Using the technical platform developed in this paper, it can be observed that RIL can become a producer of hydrogen using its existing infrastructure and technologies. Blue hydrogen can be produced by the steam methane reforming process from its natural gas production channels with Carbon Capture & Storage (CCS) through pipeline networks to offshore underground hydrocarbon reservoirs. The second area where RIL can integrate into the hydrogen supply chain is through direct electrolysis, where RIL can form direct partnerships with solar and wind power companies to produce Green Hydrogen. RIL can also collaborate with nuclear power companies for the generation of Pink Hydrogen. RIL can also partner with existing thermal power plants that use fossil fuels for power generation to create Brown Hydrogen.

However, after the performance of the LCSA assessment, the most sustainable options for RIL would be to use options A & C, having LCSA scores of 7.4 and 7.3, respectively. Option A of producing Blue hydrogen through natural gas reforming with CCS technology has an impact score of 2.4 for the environment, 2.3 for the economy, and 2.7 for society. Option C of producing Green hydrogen through electrolysis from renewable energy has an impact score of 1.6 for the environment, 3.7 for the economy and 2.0 for society. By successfully entering the





hydrogen market through the above options, RIL can contribute to India's energy security by providing an alternate low-carbon fuel to meet the country's ever-increasing energy demands.

### Conclusions

By using network analytics tools and LCSA concepts, a technical platform was developed to study the global supply chain network of hydrogen and suitable energy transition options for RIL to integrate into the hydrogen market are proposed, considering environmental, economic, and social factors. The analysis neatly fits into the current global hydrogen production scenario where only 2% of hydrogen is currently produced from electrolysis from renewable energy (IEA, 2019).

The primary aim of this paper is to equip the hydrocarbon industry's management with key insights into the LCSA method and network analytics tools. Due to relevant constraints mentioned in this research work, the management needs to ensure that the data and modelling correctly represent the broader hydrogen market by performing realistic energy systems modelling, which is vital for effectively defining decarbonization scenarios. LCSA on the whole hydrogen supply chain needs to be undertaken to fully understand the implications and implementation of future technologies (Hydrogen TCP, 2022). This can be taken up as a possible future study since mapping of the value chain is the first step towards designing a sustainable supply chain system. Hydrogen, having many universal applications, will be the key driver towards carbon-natural integrated energy systems in the future.

### References

- Reliance Industries Limited 2022a, March 06-last update, Bridging Sustainability and Growth: Target to become Net Carbon Zero by 2035 [Homepage of Reliance Industries Limited], [Online]. Available: <https://www.ril.com/ar2020-21/natural-capital.html> [2022, June/01].
- IEA 2019, "The Future of Hydrogen, Report Prepared by the IEA for the G20, Japan", Seizing Today's Opportunities.
- Osterwalder, A., Pigneur, Y., Oliveira, M.A. & Ferreira, J.J.P. 2011, "Business Model Generation: A handbook for visionaries, game changers and challengers", African journal of business management, vol. 5, no. 7, pp. 22-30.
- Ciroth, A., Finkbeiner, M., Traverso, M., Hildenbrand, J., Kloepffer, W., Mazijn, B., Prakash, S., Sonnemann, G., Valdivia, S. & Ugaya, C.M.L. 2011, "Towards a life cycle sustainability assessment: making informed choices on products",
- Hydrogen TCP 2022, May 25-last update, H2 VALUE CHAIN [Homepage of International Energy Agency], [Online]. Available: <https://www.ieahydrogen.org/> [2022, June/04].







## Which way to choose?

### Technical, economic and environmental evaluation of different hydrogen production pathways

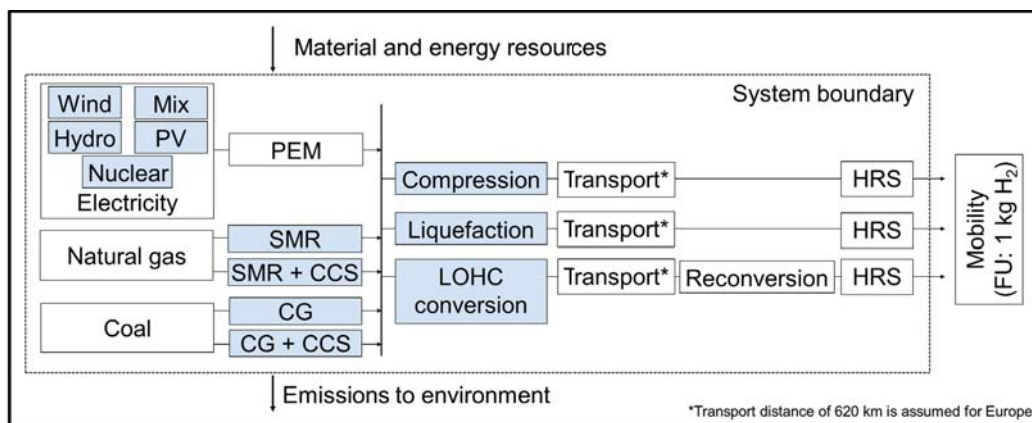
Jakob Kulawik<sup>1</sup>, +49 241 80 49875 , jakob.kulawik@eonerc.rwth-aachen.de  
 Christina Kockel<sup>1</sup>, +49 241 80 49845, christina.kockel@eonerc.rwth-aachen.de  
 Prof. Dr.-Ing. Aaron Praktiknjo<sup>1</sup>, +49 241 80 49691, apraktiknjo@eonerc.rwth-aachen.de  
<sup>1</sup>Chair for Energy System Economics, RWTH Aachen University

#### Overview

Hydrogen will play an important role as an energy vector in future energy systems. Possible applications include use in industrial processes, in building heat, in the mobility sector or as a storage for renewable energy. However, there are many unanswered questions regarding future production systems, as well as the transportation and storage options for hydrogen, which open up a multitude of possible pathways. To develop a targeted strategy for integrating hydrogen into existing energy systems, an environmental and techno-economic evaluation of individual production pathways is required. Therefore, in our research we ask the question: *What are the life-cycle emissions and costs of hydrogen production and distribution pathways in different countries and which are the critical factors driving the results?*

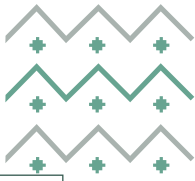
#### Methods

We carry out a life cycle assessment (LCA) and an investigation of the levelized costs of hydrogen in order to evaluate the environmental and economic potential of the identified pathways. Within the system boundary we have defined, different production processes for hydrogen, including material input for required technologies and the energy demand, are taken into account. The respective production processes are then combined with corresponding transport routes and storage options, to be able to draw conclusions about the total emissions and costs of the functional unit under consideration - one kg of hydrogen at its place of use. The respective investigation framework for our analysis is shown below.



Investigation framework for the evaluated hydrogen systems

A weakness in many of the existing LCA literature is the strong dependency of results on individual factors and assumptions within the study framework, which are often very difficult to comprehend in retrospect. In order to address this issue, our methodology includes a tool that simplifies the procedure of performing various sensitivity evaluations. This allows us to identify the most important drivers behind our results, and to better understand the reasons for the discrepancies between different hydrogen production and distribution pathways.



## Results

Our results show that there is a high potential of renewable energy-based pathways to reduce the GWP of the produced hydrogen compared to fossil-based pathways, but currently still at significantly higher costs. A high potential is also attributed to the CCS technology to reduce the GWP of the fossil-based pathways at lower costs than in the renewable energy-based pathways.

In terms of conversion and transport of hydrogen, compressed hydrogen has a higher potential for shorter road transport distances (< 200 km) and liquefied hydrogen has a higher potential for longer distances (> 500 km) from an environmental and economic point of view. However, the evaluation of conversion and transport pathways is highly dependent on the characteristics of the hydrogen economy.

Regarding hydrogen-based fuels, the highest potential is seen in the synthesis of ammonia. However, the costs of renewable energy-based pathways are considerably higher than the current market prices of the fuels investigated.

## Conclusions

Our analysis shows that there is a great variability between the economic viability and environmental impact of different hydrogen production pathways. As the integration of hydrogen within existing energy systems progresses, LCA methods can provide valuable, comprehensive insights into the advantages and disadvantages of different pathways and allow for an easier comparability of economic and environmental goals.

Our enhanced methodology for conducting sensitivity analyses helps to more clearly identify the key drivers behind our main outcomes and can contribute to making future LCA research more accessible and comparable.





## ***THE EFFECTS OF OPPORTUNITY-BASED AND NECESSITY-BASED ENTREPRENEURSHIP ON ENVIRONMENTAL PERFORMANCE: A CROSS- COUNTRY ANALYSIS***

Boumediene Ramdani, Centre for Entrepreneurship and Organizational Excellence, College of Business and Economics, Qatar University, b.ramdani@qu.edu.qa  
Fateh Belaïd, King Abdullah Petroleum Studies and Research Center, P.O. Box 88550, Riyadh 11672, KSA, fateh.belaid@kapsarc.org  
Mahmoud Abdellatif, Finance and Economics Department, College of Business and Economics, Qatar, m.abdellatif@qu.edu.qa

### **Overview**

On the one hand, the global community set a target of net-zero greenhouse gas emissions (GHGE) by 2050. Although some countries are heading on the right direction, others are failing to restrict the with rapidly rising GHGE. According to the Environmental Performance Index (EPI) (2022), unless GHGE are restricted, 24 countries will be responsible for 80% of the emissions in 2050<sup>1</sup>. On the other hand, policy makers are under pressure to develop policies that help spur entrepreneurship due to its role in job creation and economic growth (Acs et al., 2018). Although a large body of work has examined the environmental performance effects of green innovation (e.g. Chen and Lee, 2020; Wang et al., 2022), limited research exist on the environmental performance effects of entrepreneurship.

This study intends to fill this gap by examining multilevel data from for 50 countries for the period of 2002 to 2018. Our results demonstrate that necessity-based entrepreneurial efforts have a positive effect on environmental performance while the oppositive effect for opportunity-based efforts. We discuss the implication for theory as well as for pro-environment and pro-entrepreneurship policies.

### **Methods**

We use a large multilevel dataset to test our hypothese. Individual and country level data were retrived from different sources. Following previous studies (e.g. Wang et al., 2022), we use environmental performance index (EPI). EPI data from specific countries are obtained using Center for International Earth Science Information Network at Columbia University and Yale Center for Environmental Law and Policy.

Individual-level data were retrived from Global Entrepreneurship Monitor (GEM). We use the Adult Population Survey (APS) to capture the evolution of entrepreneurship over time. To augment APS, we use country-level data: GEM National Expert Survey, the International Monetary Fund (IMF), and the Index of Economic Freedom from the Heritage Foundation.

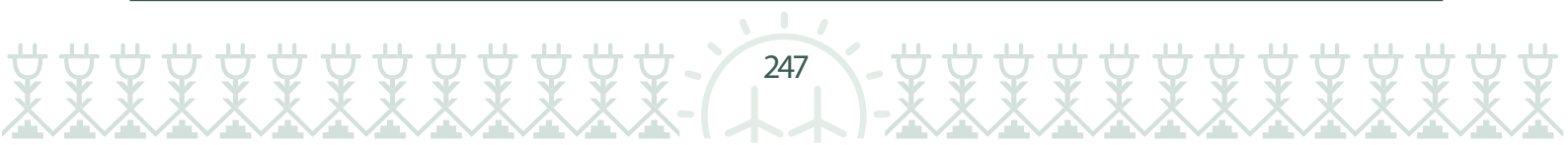
Data was analysed using hierarchical linear modeling to capture the different levels. Autio et al. (2013) encourages the use of this approach when using GEM data.

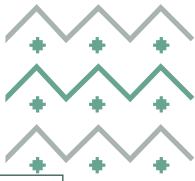
### **Results**

Our results confirm that necessity-based entrepreneurial efforts have a positive effect on environmental performance while the oppositive effect for opportunity-based efforts. This contradicts the findings of Dhahri et al. (2021), who claimed that opportunity-based efforts have a positive effect on environmental sustainability whereas necessity-based entrepreneurial efforts have a negative effect. This could be due to using several sustainable development goals (SDGs).

---

<sup>1</sup> <https://epi.yale.edu/>





## Conclusions

This study responds to recent call call by scholars to take a comparative international approach to understand the differences between countries (Terjesen et al., 2016). Given the significance of entrepreneurship to economic development as well as the importance of meeting net-zero obligations and improving environmental performance, this study contributes to our understanding of the link between the two issues.

## References

- Acs, Z. J., Estrin, S., Mickiewicz, T., & Szerb, L. (2018). Entrepreneurship, institutional economics and economic growth: An ecosystem perspective. *Small Business Economics*, 51, 501–514.
- Autio, E., Pathak, S., & Wennberg, K. (2013). Consequences of cultural practices for entrepreneurial behaviors. *Journal of International Business Studies*, 44(4), 334–362.
- Chen, Y., & Lee, C. C. (2020). Does technological innovation reduce CO2 emissions? Cross-country evidence. *Journal of Cleaner Production*, 263, 121550.
- Dhahri, S., Slimani, S., & Omri, A. (2021). Behavioral entrepreneurship for achieving the sustainable development goals. *Technological Forecasting and Social Change*, 165, 120561.
- Terjesen, S., Hessels, J., & Li, D. (2016). Comparative international entrepreneurship: A review and research agenda. *Journal of Management*, 42(1), 299-344.
- Wang, Q. J., Wang, H. J., & Chang, C. P. (2022). Environmental performance, green finance and green innovation: What's the long-run relationships among variables?. *Energy Economics*, 110, 106004.



## [FUNCTIONALIZED FULLERENES CAGES (C<sub>59</sub>M) AS PROMISING MATERIALS FOR CAPTURING ENVIRONMENTAL POLLUTIONS CO<sub>2</sub>, NO<sub>2</sub> AND SO<sub>2</sub> GASES]

[Iman Fahad Aldosari, Physics Department, Jazan University, Saudi Arabia, 0552090211, imanfahad521@yahoo.com]  
 [Ahlam EL-Barbary, Physics Department, Jazan University, Saudi Arabia, 0563976672, ael-barbary@jazanu.edu.sa]

### Overview

Energy is necessary to the continuation of life on Earth. Using energy allows us to live, travel and move as well as to light up the dark and feel fine during the winter and the summer. Most of this energy generated from fossil fuels. Using fossil fuels excessively has placed the world in front of one of the biggest problems of the era, and this has led to pollution of the Earth's atmosphere. The increasing demand for energy globally and the rapid technological progress, cause both the amount of fuel needed to generate electricity and the amount of greenhouse gases and other air pollution emitted are increased as a result.

Clean air is what all living humans and animals need for good health. However, due to unstoppable urban development, the air is continuously polluted. Urban ambient air is more polluted than the overall atmosphere due to the high density of the human population and their activities in urban areas. The atmosphere, or air, is normally composed of 79-percent nitrogen, 20-percent oxygen, and one percent mixture of carbon dioxide, water vapor, and small quantities of several other gases. When the fossil fuels are burned, the combustion gases include the emission of carbon dioxide (CO<sub>2</sub>), sulphur dioxide (SO<sub>2</sub>), nitrogen oxide (NO<sub>x</sub>) and other polluted gases. Nearly all combustion products have negative effects on the environment and human health. Where, the CO<sub>2</sub> contributes to the greenhouse effect. Although, the SO<sub>2</sub> exists in small concentrations in the earth's atmosphere, it causes acid rain, and it is found in the case of volcanic eruptions and the effluents released from industries. Nitrogen oxides (NO<sub>x</sub>) is a highly poisonous gas knowing as Nitrogen dioxide and it is one of the major atmospheric pollutants that absorb UV light and stops to reach it to the earth's surface.

The emissions caused by electricity generation vary due to many factors, including the amount of electricity is generated, the electricity generation technologies used, and the air pollution control devices used. It is difficult to control the first two factors, however the third factor needs more research to obtain promising materials to build a new devices for capturing the air pollutions to improve the air quality and hence the human health.

Therefore, this work will use the functionalized fullerene cages C<sub>59</sub>M (M=Li, He, Be, B, N, F, Al and Ti) with elements from eight different groups to select the most candidate fullerene cages to use as pollutions control through adsorption the polluted gases and captured them.

### Methods

All calculations are performed with DFT as implemented within G09W package, using B3LYP exchange-functional and applying 6-311G++(d,2p) basis set. All structures are fully optimized without any constraint. The DFT technique was used owing to the accuracy associated and confirmed in many previous work [1-12]. The electronic properties, including the density of states (DOSs), HOMO (highest occupied orbital), LUMO (lowest unoccupied orbital), Energy gaps  $E_g$ ,  $E_{FL}$  (Energy of Fermi level, and natural bond orbital (NBO) charge analysis are calculated. Also, the adsorption energies ( $E_{ads}$ ) are obtained from the following equation,

$$E_{ads} = E_{C_{59}M-gas} - (E_{C_{59}M} + E_{gas})$$

where  $E_{C_{59}M-gas}$  is the energy of the optimized C<sub>59</sub>M-gas structure,  $E_{C_{59}M}$  is the energy of the optimized C<sub>59</sub>M structure and  $E_{gas}$  is the energy of polluted gas. The energy gap between HOMO and LUMO ( $E_g$ ) was well-defined as  $E_g = E_{LUMO} - E_{HOMO}$  whereas  $E_{LUMO}$  and  $E_{HOMO}$  are energy of HOMO and LUMO.

The energy of Fermi level ( $E_{FL}$ ) that lies in the middle of the HOMO and LUMO

$$E_{FL} = \frac{E_{LUMO} + E_{HOMO}}{2}$$

The enthalpy change ( $\Delta H$ ) and Gibbs free energy change ( $\Delta G$ ) will be calculated at T=298 K and P = 1 atm as

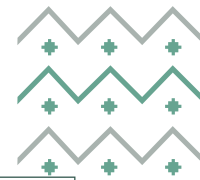
$$\Delta H = E_{C_{59}M-gas} - (H_{C_{59}M} + H_{gas})$$

$$\Delta G = G_{C_{59}M-gas} - (G_{C_{59}M} + G_{gas})$$

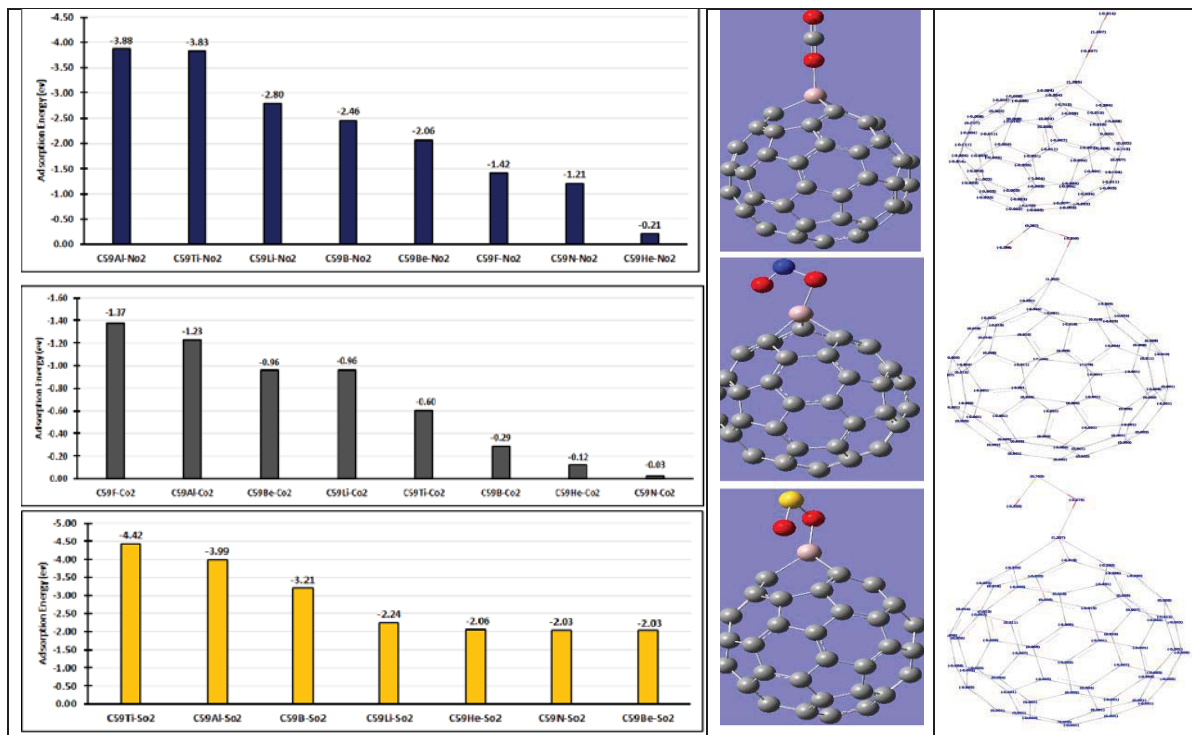
where  $H(G)C_{59}M-gas$ ,  $H(G)C_{59}M$ , and  $H(G)gas$  are the sum of electronic and thermal enthalpies (the sum of electronic and thermal free energies) of C<sub>59</sub>M-gas, C<sub>59</sub>M cages, and gas molecule, respectively.







## Results



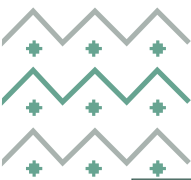
This work includes 24 fully optimized structures of adsorbed polluted gases (CO<sub>2</sub>, NO<sub>2</sub> and SO<sub>2</sub>) on functionalized fullerene cages C59M (M=Li, He, Be, B, N, F, Al and Ti) with elements from eight different groups (alkali metals, Nobel gas, Alkaline earth metal, Metalloids, non-metals, halogen, post transition metal and transition metals), respectively. The above Figure shows the adsorption energies of polluted gases are negative reflecting the powerful of functionalized fullerene cages C59M for capturing the polluted gases. Also, the natural bond orbital charge analysis and optimized structures for C59Al-CO<sub>2</sub>, C59Al-NO<sub>2</sub> and C59Al-SO<sub>2</sub> are shown as example for polluted gases captured through functionalised fullerene cage by Aluminium.

## Conclusions

Using the Density Functional Theory and applying the G09W program, the fully optimized structures, the dipole moments, the density of states, the band gaps including the HOMO and LUMO are obtained. Also, the natural bond orbital, enthalpy change, and Gibbs free energy change are studied. The results show that the functionalization of fullerene cages increases their activities to capture the polluted gases and the best functionalized fullerenes cages for capturing the polluted gases are C59Ti and C59AL.

## References

- [1] El-Barbary, A.A. (2019), International Journal of Hydrogen Energy, 44, 20099-20109.
- [2] Telling, R.H., Ewels, C.P., El-Barbary, A.A. and Heggie, M.I. (2003) Nature Materials, 2, 333-337.
- [3] Ewels, C.P., Telling, R.H., El-Barbary, A.A. and Heggie, M.I. (2003) Physical Review Letters, 91, 025505.
- [4] EL-Barbary, A.A. (2017), Applied Surface Science, 426, 238-243.
- [5] EL-Barbary, A.A. (2016) Applied Surface Science, 369, 50-57.
- [6] EL-Barbary, A.A. (2016) Hydrogenation Mechanism of Small Fullerene Cages. International Journal of Hydrogen Energy, 41, 375-383.
- [7] Suarez-Martinez, El Barbary, A.A., Savini, G. and Heggie, M.I. (2007) Physical Review Letters, 98, Article ID: 015501.
- [8] Hindi, A.A. and EL-Barbary, A.A. (2015) Journal of Molecular Structure, 1080, 169-175.
- [9] El-Barbary, A.A., Ismail, G.H. and Babaier, A. (2013) Journal of Surface Engineered Materials and Advanced Technology, 3, 287-294.
- [10] El-Barbary, A.A., Telling, R.H., Ewels, C.P. and Heggie, M.I. (2003) Physical Review B, 68, 144107.
- [11] EL-Barbary, A.A. (2015) Journal of Molecular Structure, 1097, 76-86.
- [12] El-Barbary, A.A., Lebda, H.I. and Kamel, M.A. (2009) Computational Materials Science, 46, 128-132.



## ***THE ROLE OF RENEWABLE ENERGY AND TFP IN REDUCING CO2 EMISSIONS IN RECAI COUNTRIES. FRESH INSIGHTS FROM A NEW THEORETICAL FRAMEWORK COUPLED WITH ADVANCED PANEL METHODS.***

Fakhri J. Hasanov, King Abdullah Petroleum Studies and Research Center, Phone +966 11 290 3021, E-mail: [fakhri.hasanov@kapsarc.org](mailto:fakhri.hasanov@kapsarc.org)  
Shahriyar Mukhtarov, Vistula University, Stoklosy 3, 02-787 Warsaw, Poland. Email: [s.mukhtarov@vistula.edu.pl](mailto:s.mukhtarov@vistula.edu.pl)  
Elchin Suleymanov, Baku Engineering University, Hasan Aliyev 120, AZ0101, Khirdalan, Azerbaijan, E-mail: [elsuleymanov@beu.edu.az](mailto:elsuleymanov@beu.edu.az)  
Sa'd Shannak, Qatar Environment and Energy Research Institute, Doha, Qatar, E-mail: [sshannak@hbku.edu.qa](mailto:sshannak@hbku.edu.qa)

### **Overview**

CO2 emissions have been recognized globally threat for the humanity. To curb emissions, global and country-specific programs have been launched, such as the Kyoto protocol, the Paris agreement, and United Nation (UN) Sustainable Development Goals. Given its global importance, examining driving forces of CO2 is very crucial for any economy and the Renewable Energy Country Attractiveness Index (RECAI) countries are no exception.

We use the theoretical framework developed by Hasanov et al. (2021) in this study as it links CO2 emissions to total factor productivity (TFP), renewable energy consumption (REC), alongside income, exports, and imports. There are at least two reasons for preferring this new theoretical framework to the traditional ones: (i) it offers a broader framework in informing decision-making process since it theoretically validates TFP and REC as determinants of CO2, in addition to income and international trade, (ii) these determinants have other practicality in policy considerations. TFP has long been considered the main factor of economic growth (Solow, 1957). Its two main elements, i.e., technological progress and efficiency gains, offer comprehensive opportunities not only for economic prosperity but also CO2 reduction (see e.g., Huang et al., 2020). Besides, international agencies, such as International Energy Agency, International Renewable Energy Agency, and UN environmental programs consider renewable energy among key drivers in achieving energy security, pollution reduction, and sustainable economic growth-the three important issues of the nations (e.g., UN SDG, 2015; IEA G20, 2019). Amid this international deliberation, governments all over the globe investigate options to switch from fossil fuels-based energy to renewable-based energy sources. Given the background above, the objective of this research is to investigate the CO2 impacts of REC and TFP, alongside income and international trade to propose insights that would be useful for carbon emissions reduction policies in RECAI countries.

### **Data & Methods**

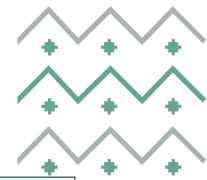
We used panel annual time series data spanning between 1990 to 2018 for 20 RECAI countries for the following variables. Consumption-based CO2 emissions (CO2). This is territory-based CO2 emissions excluding CO2 emissions embodied in exports and including CO2 emissions embodied in imports. This is our dependent variable and is measured in million tones and taken from Global Carbon Atlas (2019). Renewable energy consumption (REC). This is the consumption of the energy obtained from renewable sources as the percentage share of total energy consumption. The values of the variable were gathered from World Development Indicators database, WDI (2020). Total Factor Productivity (TFP). This is total factor productivity index collected from the Penn World Table 10.0 database. Income (GDP). This is the final value of goods and services that are produced within the boundaries of RECAI countries at a specific time. It was measured in constant 2010 US dollars and adjusted for purchasing power parity. Exports (EX). This is the exports of goods and services at constant 2010 US dollars as the percentage share of GDP. Imports (IM). This is the imports of goods and services at constant 2010 US dollars as the percentage share of GDP. GDP, EX, and IM are collected from WDI (2020). The countries are Australia, Brazil, Canada, Chile, China, Denmark, Egypt, France, Germany, India, Ireland, Israel, Italy, Japan, Morocco, Netherlands, Spain, Sweden, UK, and USA.

We first perform Pesaran (2015) test and it showed that the variables have strong cross-sectional dependency (CD) effect. Hence, we used the second-generation panel methods: Pesaran (2007) test for unit root, Westerlund (2007) test for cointegration, Pesaran (2006) common correlated effect mean group estimator (CCEMGE) and Eberhardt and Teal (2010) the augmented mean group estimator (AUGMGE) for long-run estimations. The imperative advantage of the latter three methods is that they produce cointegration test and estimation results for each individual country alongside the aggregate panel results. Just for comparison purpose, we also used first-generation methods of the fixed effect estimator (FEE) and random effect estimator (REE).

### **Results**

Pesaran (2015a) test showed that the variables have the CD effect and Pesaran (2006) unit root test indicated that they are non-stationary in their log levels and stationary in their growth rates. Westerlund (2007) cointegration test confirmed that CO2 establishes a long run relationship with the above listed explanatory variables (the test results are not reported here due to the space limitation but can be obtained from the authors). To this end, we estimated





the parameters of long-run relationship for CO2. Table 1 documents the results.

**Table 1.** Long-run estimation and test results.

	AUGMGE	CCEMGE	FEE	REE
<i>rec</i>	-0.277*** (0.000)	-0.135*** (0.000)	-0.215*** (0.000)	-0.213*** (0.000)
<i>tfp</i>	-0.350* (0.053)	-0.370 (0.167)	-0.673*** (0.000)	-0.636*** (0.000)
<i>ex</i>	-0.275*** (0.001)	-0.267*** (0.003)	-0.331*** (0.000)	-0.337*** (0.000)
<i>im</i>	0.288*** (0.000)	0.240*** (0.006)	0.370*** (0.000)	0.372*** (0.000)
<i>gdp</i>	0.819*** (0.000)	0.724*** (0.000)	0.836*** (0.000)	0.821*** (0.000)
CADF	C&T	-8.711 (0.000)	-14.559 (0.000)	-1.516 (0.065)
	C	-11.399 (0.000)	-16.636 (0.000)	1.645 (0.950)
				1.569 (0.942)

**Notes:** The dependent variable is *co2*; Lower-case letters denote the natural logarithmic transformation of the variables listed in the previous section. p-values are in parentheses; \*\*\*, \* mean statistical significance at the 1% and 10%, respectively. Deterministic terms are not reported for simplicity; time series observations=29; countries=20; CCEMGE and AUGMGE are run with the option of robust standard errors; CADF is the Pesaran (2007)' cross-sectionally augmented Dickey-Fuller unit root test (the test equation was run in two options: (i) with constant and trend (C&T) and (ii) with constant only (C), and both with zero lag as it turned out to be the most relevant lag order for residuals).

AUGMGE results showed that, holding other factors constant, a 1% increase (decrease) in RE, TFP, and EX leads to a reduction (rise) in CO2 by 0.3%, 0.4%, and 0.3%, respectively in the long run. Also, in ceteris paribus, CO2 can be decreased (increased) by 0.3% and 0.8%, respectively if IM and GDP decrease (increase) by a 1%.

### Conclusions

A finding of a strong CD effect implies that there are country-wise dependence and/or unobserved common factors that affect all 20 RECAI countries. These factors may include, but not limited to, technology transfers, global energy and financial shocks, institutional memberships, regional and international trade organizations. The unit root test results concluded that shocks could create permanent changes in the log level of the variables, but they could create only temporary changes in the growth rates of them. The cointegration test results concluded that stochastic development trends in the CO2 and its determinants can cancel out each other making deviations from the long-run equilibrium relationship of CO2 temporary not permanent.

A couple of conclusions from the long-run estimations in Table 1 are worth considering. *First*, CO2 is negatively related to RE, TFP, EX and positively associated with IM and GDP in the long run regardless of whether we account for the common unobserved factors or not. In the case of the CCEMGER and AUGMGER methods, this finding originates from the individual country estimates: RE and TFP exert a negative impact on CO2 in 17 and 14 countries, respectively out of 20 countries. EX, IM, and GDP have their theoretically expected negative, positive and positive impacts in 16, 17, and 16 countries, respectively (the results are available from the authors). *Second*, the size of the impact of RE, EX, IM, and GDP on CO2 does not change largely and are around -0.2, -0.3, 0.3, and 0.8, respectively across the four methods. This implies that not accounting for the common unobserved factors does not change the impact size considerably in the RECAI countries. When it comes to TFP impact size, one can conclude that TFP and unobserved factors that are common for these RECAI countries are associated. This is probably because there are factors that are common for the countries and are part of TFP at the same time such as technological progress, efficiency gains.

The main policy implication of the findings is that authorities should implement measures to boost TFP and RE as they are mostly driven by the factors, such as technological progress, innovations, efficiency gains, which can reduce CO2 emissions and promote long-run economic growth at the same time.

### References

Eberhardt, M. and Teal, F. 2010. Productivity Analysis in Global Manufacturing Production, Economics Series Working Papers 515, University of Oxford, Department of Economics

IEA G20 2019. Technology Innovation to Accelerate Energy Transitions: High-level recommendations for G20 priority action. International Energy Agency and G20 Japan, 2019.

Huang, J., Chen, X., Yu, K., & Cai, X. (2020). Effect of technological progress on carbon emissions: New evidence from a decomposition and spatiotemporal perspective in China. *Journal of Environmental Management*, 274, 110953.

Hasanov, F.J., Khan, Z., Hussain, M. and Tufail, M., 2021. Theoretical framework for the carbon emissions effects of technological progress and renewable energy consumption. *Sustainable Development*, 29(5), pp. 810-822.

Pesaran, M.H. 2006. Estimation and Inference in Large Heterogeneous Panels with a Multifactor Error Structure, *Econometrica*, Vol. 74(4): pp. 967-1012.

Pesaran, M.H. 2007. A Simple Panel Unit Root Test in The Presence of Cross-Section Dependence, *Journal of Applied Econometrics*, 22(2), pp. 265-312.

Pesaran, M.H. 2015. Testing Weak Cross-Sectional Dependence in Large Panels, *Econometric Reviews*: 1089-1117.

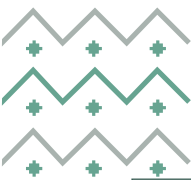
Pesaran, M.H., 2015a. "Time Series and Panel Data Econometrics", Oxford University Press.

Solow, R.M. 1957. "Technical change and the aggregate production function." *The Review of Economics and Statistics*: 312-320.

UN SDG, 2015. Sustainable Development Goals. United Nations Development Program.

Westerlund, J. 2007. Testing for Error Correction in Panel Data, *Oxford Bulletin of Economics and Statistics*: 709-748.





## ***THE FOUR DIMENSIONS (4Ds) OF ENERGY TRANSITION: DECARBONIZATION, DECENTRALIZATION, DECREASING USE, AND DIGITALIZATION***

Muhammad Asif

King Fahd University of Petroleum and Minerals Dhahran, KSA

Email: [asifm@kfupm.edu.sa](mailto:asifm@kfupm.edu.sa), Mob: 00966540649188

### **Overview**

The human use of energy has evolved through the course of history. The availability of refined and efficient energy resources has played a decisive role in the advancement of societies, especially since the industrial revolution of the eighteenth century. In the twenty-first century, the international energy scenario is experiencing a profound transition as the world is experiencing a major shift in terms of energy resources and their utilization. In recorded history, there have been two major energy transitions. The first one was a shift from wood and biomass to coal during the 18th century industrial revolution, and the second one was the 20th century transition from coal to oil and gas. The 21st century energy transition is manifested as a sustainable energy transition or zero-carbon energy transition. This work examines the major dimensions of the unfolding energy transition taking into account key policy drivers and trends, technologies, challenges, and prospects.

### **Methods**

The work explores the international energy and environmental scenario to determine the important technological and policy dimensions of the ongoing energy transition. It examines the frameworks, directives, and outlooks of relevant national and international bodies and policy institutions, utilities, industry, academia, research and development (R&D) organizations, and the development sector. A survey has also been conducted to determine the perspective of key stakeholders - i.e. policy and decision-making circles, utilities, industry, academia, research and development (R&D) institutes, financial institutes, developmental sector, and civil society - on the dynamics of the energy transition.

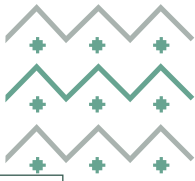
### **Results**

- The main findings of the work are as below.
- The key drivers of the ongoing energy transition include: climate change, energy insecurity, rising energy prices, and depleting fossil fuel energy reserves.
- The technological dimensions of energy transition can be classified under four broader categories: decarbonization, decreased use (energy efficiency), decentralization/distributed generation, and digitalization
- Major challenges to a successful energy transition include a lack of conducive policies, technological and investment constraints, and geopolitical disputes
- The energy transition requires a dynamic and interwoven technology-policy partnership
- Localized socio-economic inequalities around energy insecurity are also a global concern
- The planet, a global village, has a shared future, for the developed and developing nations.

### **Conclusions**

The 21st-century energy transition is much more vibrant and multidimensional as compared to the 19th and 20th-century energy transitions thanks to the enormous changes and advancements on the fronts of energy resources and their consumption, technological advancements, socio-economic and political response, and evolving policy-landscape. This energy transition is driven by the global pursuit of sustainable development having energy and environmental sustainability at its heart. In terms of technology, the present energy transition has four broader dimensions: decarbonization, decreased use, decentralization, and digitalization. Decarbonization of the energy sector is led by solutions like renewable and low-carbon technologies, electric mobility, carbon capture and storage, and hydrogen and fuel cells. Decreased use of energy through energy conservation and management (ECM) is critical to energy sustainability. ECM is a widely established and techno-economically viable strategy across all major energy-consuming sectors. Distributed generation or decentralized energy systems are becoming popular around the world to





help cost-effective and efficient supplies of energy. Digitalization of energy systems is also deemed to be an important aspect of future energy systems. The International Energy Agency (IEA), regards energy digitalization as important to help improve productivity, accessibility, cost-effectiveness, and overall sustainability of future energy systems.

#### References

1. M. Asif, The 4Ds of Energy Transition: Decarbonization, Decreasing use, Decentralization, and Digitalization, Wiley, ISBN: 978-3-527-34882-4, 2022
2. M. Asif, Handbook of Energy and Environmental Security, Elsevier, ISBN: 9780128240847, 2022







### Effective options for addressing air quality– related environmental public health burdens in Saudi Arabia

Jared Woollacott, RTI International, [jwoollacott@rti.org](mailto:jwoollacott@rti.org)  
Wael Alsufyani, Public Health Authority of Saudi Arabia, [wasufyani@cdc.gov.sa](mailto:wasufyani@cdc.gov.sa)  
Robert H. Beach, RTI International, [rbeach@rti.org](mailto:rbeach@rti.org)  
Laura T. R. Morrison, RTI International, [lmorrison@rti.org](mailto:lmorrison@rti.org)  
Alison Bean de Hernandez, RTI International, [abean@rti.org](mailto:abean@rti.org)  
Severin Rakic, World Bank Group, [srakic@worldbank.org](mailto:srakic@worldbank.org)  
Mashael AlOmran, Public Health Authority of Saudi Arabia, [msomran@cdc.gov.sa](mailto:msomran@cdc.gov.sa)  
Reem F. Alsukait, King Saud University, [ralesukait@ksu.edu.sa](mailto:ralesukait@ksu.edu.sa)  
Christopher H. Herbst, World Bank Group, [cherbst@worldbank.org](mailto:cherbst@worldbank.org)  
Salem AlBalawi, Public Health Authority of Saudi Arabia, [smbalawi@cdc.gov.sa](mailto:smbalawi@cdc.gov.sa)

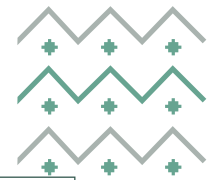
### Overview

Air pollution remains a major contributor to the global burden of disease, accounting for approximately 10% of annual deaths globally (WHO, 2016). Ambient concentrations of fine particulate matter (PM; where fine is 2.5 µm or less, PM2.5), ozone (O3), sulfur dioxide (SO2), and oxides of nitrogen (NOx) contribute to a variety of illnesses. Saudi Arabia experiences deaths attributable to outdoor air pollution at a much greater rate than other countries of comparable income (Our World in Data, 2019; World Bank, 2020). Common sources of combustion emissions in Saudi Arabia are transportation, electricity, and water desalination. Saudi Arabian shipping supports large trade volumes of 7.1 million barrels per day of oil and 8.9 million twenty-foot equivalent units (TEUs—i.e., shipping containers) (World Bank, 2021). This research is designed to assess existing evidence and recommendations on effective options for addressing environmental public health burdens in Saudi Arabia. Specifically, what effective technologies and policy options are available for avoiding exposure to existing air pollution and what are the key drivers of their effectiveness relevant to the Saudi Arabian context? And also What cost effective technology and policy options are available for preventing air pollution and what are the key drivers of their costs relevant to the Saudi Arabian context?

### Methods

We conduct a semi-systematic literature review of available costs and effectiveness information. The literature review is designed to cover the two distinct approaches to addressing environmental public health concerns by either (1) adapting to existing pollution through avoidance measures or (2) mitigating air pollution sources through pollution control measures. We evaluate the availability, content, and relevance of cost and effectiveness information from our search results for efficiently and effectively addressing the prevailing sources and ambient pollution in Saudi Arabia. For adaptation, we first identified options—ranging from air filtration to air quality warning systems—for avoiding poor ambient air quality. For mitigation, we searched for both technologies and policies designed to reduce air pollutant emissions. Each search includes the pollutants relevant to the air quality hazards identified by the WHO. We conducted literature searches for adaptation responses to reduce exposure to pollution in both the Web of Science and PubMed and literature searches for pollution mitigation in the Web of Science only, with all searches over the years 2011–2021. We retrieved a list of titles, authors, abstracts, and select other bibliometric information for all our literature search results. We then organized the results by adaptation and mitigation and divided mitigation results into those returned with the search term “policy” and those with the search term “technology,” forming three sets of results for our review. We assigned one author per result set (i.e., adaptation, mitigation technology, and mitigation policy) to review and rate each result on four criteria (enumerated below) based on abstract and title. We removed duplicate results within each of these three sets of results but not across them, leaving results to be scored multiple times and compared to assess inter-rater reliability. We ranked papers as “confident criterion is not met” (0), “not confident whether criterion is met” (0.5), or “confident the criterion is met” (1.0) for each of the four inclusion criteria. One reviewer and all received consistent scoring of either 3.5 or greater or less than 3.5. Finally, we re-ranked results in our full-text review on the same criteria as in the abstract review. One reviewer and all received consistent scoring of either 3.5 or greater or less than 3.5. Finally, we re-ranked results in our full-text review on the same criteria as in the abstract review. From the full-text reviews, we summarized both qualitative information on mitigation and adaptation interventions and their effectiveness. All papers receiving a score of 3.5 were reviewed for our qualitative summaries. For quantitative mitigation results, we required that the study provide quantitative cost and abatement information in





the form of either currency per emission unit reduced (e.g., USD/tonne) or a cost followed by a reduction in emissions so that cost-effectiveness could be calculated. On some occasions, we also had to estimate the pollution reduction amount. Some of the studies provided a baseline value and percent reduction.

## Results

In total, our literature searches returned 3,068 articles, two-thirds of which came from the adaptation search and 748 of which were duplicates within searches. The mitigation searches returned similar numbers of technology and policy results. The initial screening, based on abstract and title, excluded 1,890 articles that did not receive a scoring of 3.5 or higher in our review. We recategorized articles that were determined to be a better fit for a category other than the one they were initially identified under (e.g., mitigation policy rather than mitigation technology) and removed duplicate articles that were identified in multiple searches, leaving 335 articles for full text review, 276 of which we excluded for not meeting the screening criterion after full text review. The qualitative and quantitative results that follow are based on a full text review of 59 articles passing all stages of our screening. Figure 3 provides a Preferred Reporting Items for Systematic Reviews and Meta-Analyses (PRISMA) statement of our literature review process across our searches. The review of adaptation measures to address air quality identified 12 studies that detail effectiveness and/or cost information. Of the studies identified in the review, all discussed effectiveness information and only one discussed cost. The measures identified can be taken by society, a household, and/or an individual. Of those identified, most studies examined air quality messaging systems that use constructed indices for communication to the public. Other studies identified examined measures to reduce human exposure to automobile traffic in urban settings, indoor air filtration and ventilation, and personal mask usage.

Although there is substantial interest in identifying and characterizing cost-effective technologies for mitigating air pollution, our search of the literature found relatively few studies in the academic literature that meet our search criteria. Generally, there is wide variation in estimated costs associated with alternative mitigation technologies, partly because the cost of reducing a given level of emissions depends heavily on the incremental costs of the mitigation technologies as well as the emissions reduction efficiency available at each emitting facility. Table 2 summarizes the findings of our review of recent literature with sufficient information to derive estimates of cost-effectiveness. We separated the available observations into those based on controlling single pollutants and those assessing the simultaneous control of multiple pollutants. Among the estimates assessing single pollutants, the majority (24 estimates) focused on PM, followed by NO<sub>x</sub> (11), and SO<sub>2</sub> (10). The median costs per tonne reduced were similar for PM and NO<sub>x</sub>, with both exceeding the median cost-effectiveness of mitigating SO<sub>2</sub> by more than three times. The ranges are so large that they all overlap, though the interquartile range of cost-effectiveness for SO<sub>2</sub> is substantially lower and narrower than it is for PM or NO<sub>x</sub>. Negative costs imply that some opportunities exist for cost savings (e.g., through efficiency improvements) in controlling emissions.

Mitigation policies are designed to encourage market participants to put into effect pollution control technologies that would not be privately economical. Pollution mitigation policies are innumerable in their specific provisions and regulatory requirements. In terms of categories, they include one or more of the following mechanisms to induce the adoption of pollution controls: (1) taxes or subsidies provide direct economic penalties or incentives for polluting for mitigating pollution; (2) permitting schemes create a restricted commodity for pollution, limiting a quantity or emissions rate; (3) "command-and-control" approaches require specific action by emitters; (4) public information and other nonpecuniary and non-remunerative policies can help encourage the adoption of mitigation options where individuals or firms may find it privately beneficial to do so given sufficient information (e.g., explaining the cost savings of energy efficiency upgrades).

The effectiveness of adaptation options at reducing pollution exposures suggests that policies that provide actionable information (e.g., air quality alerts) and that subsidize required resources (e.g., equipment) could provide cost-effective environmental public health improvements in Saudi Arabia. Still, our literature review did not identify robust cost-benefit evaluations of environmental public health adaptation policies, and the centrality of behavioral responses in determining the effectiveness of such policies suggests that existing studies may not generalize well to other populations. Behavioral responses include populations' responsiveness to air quality information; their financial capacity to invest in air quality equipment; their willingness to invest given how they value and discount future air quality benefits against up-front investment costs; and their ability and willingness to operate air quality equipment at optimal efficiency. For example, face masks may be excessively hot to wear outdoors in Saudi Arabia's climate, separating pedestrian spaces from vehicular traffic may be costly given the country's current infrastructure, and such separation may also be inconvenient or otherwise undesirable for pedestrians.





## Conclusions

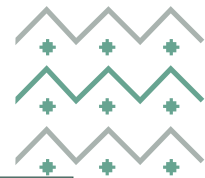
Significant opportunity exists for improving environmental public health in Saudi Arabia relative to the standards enjoyed by its peers by income. While existing international guidelines such as those from the WHO provide a helpful reference point for ambient air quality goals, they lack the cost and performance specificity for technologies and policies needed to address the air quality challenges Saudi Arabia faces. To address this gap, this review focused on the level and determinants of the effectiveness of mitigation and adaptation options for addressing environmental public health. We reviewed approximately 3,000 peer-reviewed publications relevant for improving environmental public health outcomes in Saudi Arabia. Our literature review identified research with effectiveness evaluations of specific pollution control interventions relevant to Saudi Arabia. Our review focused on technologies and policies available for mitigating and adapting to some of the most prominent air pollutants relevant to environmental public health: PM, NOX, and SO<sub>2</sub>.

Pollution mitigation technologies are myriad and, while they may be thoroughly studied and demonstrated as effective, must be evaluated in the Saudi context. Technology costs also vary widely. The specific costs that apply to Saudi Arabia must be determined through local engineering evaluations of existing and potential new sources. Policies that allow for flexibility in who mitigates their emissions will generally provide firstbest options for cost minimization; however, important spatio-temporal heterogeneity exists in benefits and distributional equity considerations that must be factored into policy design. For the pollution that is not mitigated, several important adaptation strategies exist for creating less polluted indoor environments, filtering outdoor air with face masks, avoiding outdoor areas with especially hazardous pollution levels, and raising public awareness of pollution hazards when and where they exist. The literature suggests that these adaptation measures are effective at reducing exposure, but their cost-effectiveness requires further study with local relevance. Saudi-specific evaluations of adaptation measures may be especially important, as many local determinants of adaptation effectiveness exist, including behavioral responses and local infrastructure.

Our review found that adaptation has the least available information, especially with respect to cost effectiveness evaluations. We also found relatively few relevant studies on technology cost-effectiveness. While this may be partly the result of the "durability" of older technical reports and studies, up-to-date, local information remains a necessity for new environmental public health initiatives in locations that have less pollution control history such as Saudi Arabia. The policy cost evaluations identified several different important aspects of policy design but offered relatively little on optimal multipollutant policy design. While highly relevant for broadscale environmental public health efforts, such research may be primarily theoretical and therefore would have been excluded by our literature review for lack of specificity.

Future research evaluating specific multipollutant outcomes from policy interventions in diverse settings would serve this literature well. While techno-economic, economy-wide simulation modeling can be very informative, it is an incomplete substitute for empirical evidence of policy effectiveness. Still, richer simulations of diverse physical and techno-economic systems can greatly enhance policy evaluations by combining atmospheric modeling, spatially rich information on infrastructure and exposed populations, and multisectoral techno-economic characterization of pollution-generating activities. Such studies remain scarce and geographically under-diversified. Finally, behavioral studies that can account for individual and institutional biases in responding to policy initiatives over a greater range of socio-demographic diversity and with local relevance to countries expected to significantly expand their pollution control regimes such as Saudi Arabia can greatly enhance our understanding of policy effectiveness.





## Long term energy policy vs. dynamic public preferences? A review of German energy policy 2008-2023

Christina Kockel<sup>1</sup>, +49 241 80 49845, Christina.Kockel@eonerc.rwth-aachen.de

Aaron Praktiknjo<sup>1</sup>, +49 241 80 49691, APraktiknjo@eonerc.rwth-aachen.de

<sup>1</sup>RWTH Aachen University, Institute for Future Energy Consumer Needs and Behavior (FCN)

### Overview

The current energy crisis imposes even greater challenges to the on-going efforts to decarbonize the energy sector. Until only recently, Germany's strategy towards a secure, affordable, and environmentally sustainable energy system was highly reliant on efficient natural gas-fired power plants to support volatile power generation from renewable energies (German Federal Government, 2021). These plans included the gradual phase-out of coal power plants until 2038 the latest (with the coalition agreement aiming for 2030) and of nuclear power plants until the end of 2022. However, due to an increased scarcity and high prices for natural gas leading to sharp increases of electricity prices, calls within the German population demanding the extension of the operating life of coal and nuclear power plants are increasing.

This development would not be the first rapid change in energy policy under pressure from the population and thus the electorate. For example, in 2011 the nuclear phase-out was decided – after the nuclear power plants were actually extended in 2010 – based on strong protests after the nuclear accident in Fukushima and in 2020 the first coal phase-out law was passed after the Friday for Future movements with support of large parts of the population put pressure on the government. Fundamental for these rapid changes seem to be the changing preferences in society towards the three energy policy targets – security of supply, environmental sustainability and affordability. Against this backdrop, we ask:

Is long term energy policy possible if it is highly dependent on public preferences?

### Methods

To analyze this, we look at past long-term scenarios from 2008 onward and compare them with the preferences towards the energy policy targets at that time. For the goals of long-term energy policy we have reviewed long term studies and laws by the government such as the lead scenario 2009 of the German government (Nitsch & Wenzel, 2009), the prolongation of nuclear power plants (German Federal Government, 2010), and the nuclear (German Federal Government, 2011) as well as the coal phase-out act (BGBl., 2020). To investigate preferences we reviewed existing surveys regarding the preferences towards the goals of the energy policy target triangle at the time. For example Praktiknjo (2013) conducted a discrete choice experiment weeks after the nuclear accident in Fukushima in March 2011. In order to classify the current energy policy changes regarding the preferences of the population, we conduct another discrete choice experiment like this and we compare the assumptions of the scenarios with today's actual values in terms of environmental sustainability, security of supply and affordability.





## Results

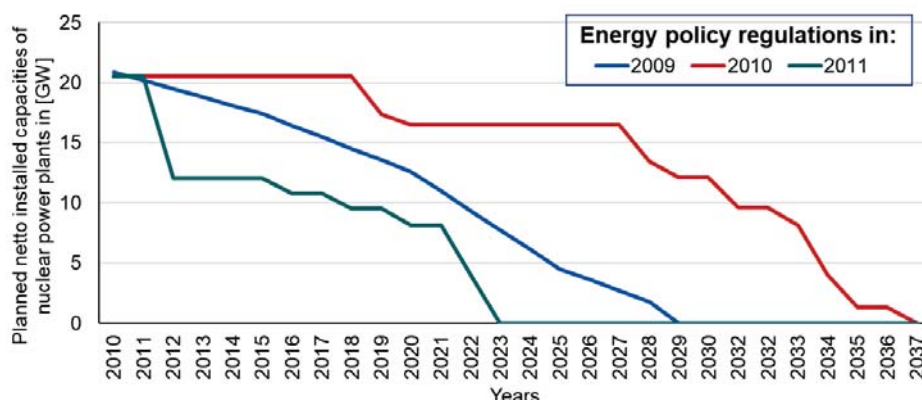


Figure 1: Planned installed netto capacities of nuclear power plants based on the energy policy regulations in 2009 (Nitsch & Wenzel, 2009), 2010 (German Federal Government, 2010) and 2011 (German Federal Government, 2011)

As an example of the rapid changes in German energy policy, Figure 1 shows the planned installed capacity for nuclear power plants based on the laws of 2009, 2010 and 2011. Comparing it to the surveyed preferences by Praktijnjo (2013) of the German population shortly after the nuclear accident in Fukushima in 2011, shows the influence of public preferences on long term energy policy clearly. The strong preference for phasing out nuclear power compared to security of supply as shown in Figure 2 is accompanied by a significant reduction in future planned nuclear power plants even though most nuclear power plants were just prolonged in 2010.

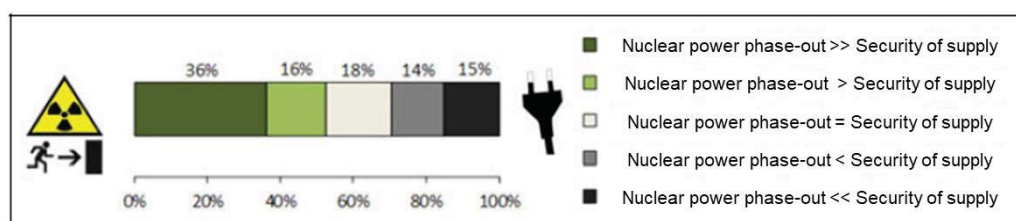


Figure 2: Preferences of the German population shortly after the nuclear accident in Fukushima in 2011 from Praktijnjo (2013)

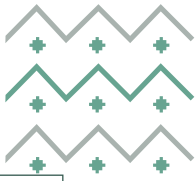
## Conclusions

We take a retrospective look at the preferences of the population in Germany with regard to the energy policy target triangle and the scenarios for energy policy developed from it. This analysis could help to understand the weighing of energy policy target preferences and how German energy policy depends on the view of the electorate. This is relevant because energy policy requires measures and regulations that are durable, especially due to the long-term nature of the energy system and its components. Knowing how people form preferences can therefore help to make both short-term and long-term policies more effective. At the same time, it can serve as a basis for implementing measures based on the preferences of the population that benefit the people but also lead to a sustainable transformation to a fossil-free power system.

## References

- BGBI. (2020). Gesetz zur Änderung des Erneuerbare-Energien-Gesetzes und weiterer energierechtlicher Vorschriften (Act Amending the Renewable Energy Sources Act and Other Energy Law Provisions).
- German Federal Government. (2010). Entwurf eines Elften Gesetzes zur Änderung des Atomgesetzes (Draft Eleventh Act Amending the Atomic Energy Act).
- German Federal Government. (2011). Entwurf eines Dreizehnten Gesetzes zur Änderung des Atomgesetzes ( Draft Thirteenth Law Amending the Atomic Energy Act).
- German Federal Government. (2021). Koalitionsvertrag 2021 – 2025: Mehr Fortschritt wagen, Bündnis für Freiheit, Gerechtigkeit und Nachhaltigkeit. (Coalition agreement 2021—2025: Dare more progress, alliance for freedom, justice and sustainability.).
- Nitsch, J., & Wenzel, B. (2009). Langfristszenarien und Strategien für den Ausbau erneuerbarer Energien in Deutschland unter Berücksichtigung. Bundesministerium für Umwelt, Naturschutz und Reaktorsicherheit (BMU), (Federal Ministry for the Environment, Nature Conservation and Nuclear Safety, 19.
- Praktijnjo, A. (2013). Sicherheit der Elektrizitätsversorgung: Das Spannungsfeld von Wirtschaftlichkeit und Umweltverträglichkeit. Springer Vieweg.





## **LINKING ELECTRICAL GRIDS BETWEEN EUROPE AND THE MENA REGION: POTENTIALS AND OPPORTUNITIES**

Menna Elsobki, Aaron Praktiknjo  
RWTH Aachen University, Institute for Future Energy Consumer Needs and Behavior (FCN), Chair for Energy System Economics  
+49 241 80 [49874; 49691]

### **Overview**

In view of the climate targets that are to be achieved as well as the growing efforts to mitigate greenhouse gas emissions, the transition of the energy sector is imperative. In order to ensure the security of supply of electricity, while the share of renewable energies in the electricity mix increases, the interconnection of electrical transmission networks between neighbouring countries and overseas gains more importance.

Both the Kingdom of Saudi Arabia and Egypt enjoy a high potential for producing electricity from renewable energies especially solar. In addition to that, a DC transmission line with a capacity of 3 GW between both countries is under construction. All of this would facilitate the production of electricity beyond their domestic needs, making it possible to export the electricity surplus to the Mediterranean basin links. The paper aims to assess potentials and opportunities when connecting the MENA region with Europe through the planned HVDC link between Greece and Egypt.

### **Methods**

In order to estimate the potential energy electricity surplus in parts of the MENA region that can be exported to Europe, an analysis of the currently available and planned generation on the one hand and the expected load on the other hand should be conducted. Since the planned MENA-Europe electrical grid linkage is going to connect primarily the electrical grid of Egypt and that of Greece, the energy generation and the electrical load time series of Egypt are going to be predominantly examined. Additionally the electricity generation and load profiles of neighbouring countries of Egypt in particular the Kingdom of Saudi Arabia are of interest. The importance of taking into consideration the Kingdom of Saudi Arabia goes back to the planned DC transmission line enabling the import and export between the two neighbouring countries. This paper will take into consideration the availability of the current and future renewable resources as well as the transmission capacities between the upper mentioned countries. By considering the electrical generation and load profiles of both countries primarily, the electrical energy surplus in an hourly time resolution can be derived. Accordingly, the amount of electrical energy export to Greece and in which time periods the export can take place can be determined.

In the context of the evaluation of traded electrical energy between the countries, there are two aspects namely the economical and the ecological benefits that strike interest. This paper aims to look into the future operation of the Egyptian power grid while optimizing the operation of the electrical grid on the basis of the availability of renewable energies and hence minimizing the CO<sub>2</sub> emissions or on the basis of maximising the economic benefits of the concerned country parties.

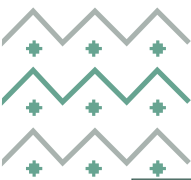
### **Results**

The preliminary result show that Egypt will have a surplus during the early hours of the day while the surplus in Saudi Arabia is going to be found in the late afternoon.

### **Conclusions**

The proposed scheme would be used as a planning operational tool to assess the current and imminent sustainable electricity resources available collectively in both the Kingdom of Saudi Arabia and Egypt to provide electricity from renewables to European electric utilities. Through the described approach, incentives in the MENA-region especially in Egypt and the Kingdom of Saudi Arabia can be derived from the future optimal operation of the power grid.





## **LINKING ELECTRICAL GRIDS BETWEEN EUROPE AND THE MENA REGION: POTENTIALS AND OPPORTUNITIES**

Menna Elsobki, Aaron Praktiknjo  
RWTH Aachen University, Institute for Future Energy Consumer Needs and Behavior (FCN), Chair for Energy System Economics  
+49 241 80 [49874; 49691]

### **Overview**

In view of the climate targets that are to be achieved as well as the growing efforts to mitigate greenhouse gas emissions, the transition of the energy sector is imperative. In order to ensure the security of supply of electricity, while the share of renewable energies in the electricity mix increases, the interconnection of electrical transmission networks between neighbouring countries and overseas gains more importance.

Both the Kingdom of Saudi Arabia and Egypt enjoy a high potential for producing electricity from renewable energies especially solar. In addition to that, a DC transmission line with a capacity of 3 GW between both countries is under construction. All of this would facilitate the production of electricity beyond their domestic needs, making it possible to export the electricity surplus to the Mediterranean basin links. The paper aims to assess potentials and opportunities when connecting the MENA region with Europe through the planned HVDC link between Greece and Egypt.

### **Methods**

In order to estimate the potential energy electricity surplus in parts of the MENA region that can be exported to Europe, an analysis of the currently available and planned generation on the one hand and the expected load on the other hand should be conducted. Since the planned MENA-Europe electrical grid linkage is going to connect primarily the electrical grid of Egypt and that of Greece, the energy generation and the electrical load time series of Egypt are going to be predominantly examined. Additionally the electricity generation and load profiles of neighbouring countries of Egypt in particular the Kingdom of Saudi Arabia are of interest. The importance of taking into consideration the Kingdom of Saudi Arabia goes back to the planned DC transmission line enabling the import and export between the two neighbouring countries. This paper will take into consideration the availability of the current and future renewable resources as well as the transmission capacities between the upper mentioned countries. By considering the electrical generation and load profiles of both countries primarily, the electrical energy surplus in an hourly time resolution can be derived. Accordingly, the amount of electrical energy export to Greece and in which time periods the export can take place can be determined.

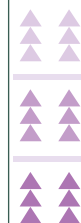
In the context of the evaluation of traded electrical energy between the countries, there are two aspects namely the economical and the ecological benefits that strike interest. This paper aims to look into the future operation of the Egyptian power grid while optimizing the operation of the electrical grid on the basis of the availability of renewable energies and hence minimizing the CO<sub>2</sub> emissions or on the basis of maximising the economic benefits of the concerned country parties.

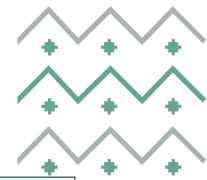
### **Results**

The preliminary result show that Egypt will have a surplus during the early hours of the day while the surplus in Saudi Arabia is going to be found in the late afternoon.

### **Conclusions**

The proposed scheme would be used as a planning operational tool to assess the current and imminent sustainable electricity resources available collectively in both the Kingdom of Saudi Arabia and Egypt to provide electricity from renewables to European electric utilities. Through the described approach, incentives in the MENA-region especially in Egypt and the Kingdom of Saudi Arabia can be derived from the future optimal operation of the power grid.





Paper Abstract for IAEE Meeting In Kingdom of Saudi Arabia, February 2022

**Why Invest in Hydrogen? A Sustainable Path Forward**

John Ballantine, PhD, Senior Lecturer, Brandeis University  
 Mohammed AlMehdar, PhD Candidate, Brandeis University  
 September 9, 2022

Most energy scenarios paint a significant yet declining role for fossil fuel producers as we transition to a greener and possibly 1.5 - 2-degree COP 26 world (Paltsev, Ansari & Holtz, table 1). Of course, getting there by 2050 requires a huge – many trillions of dollars – investment in our energy infrastructure, particularly following the Ukraine war with the dramatic shift in Europe / Germany from Russian gas to LNG and sustainable sources. (Rystad, IEA). Global energy producers are fully aware of the uncertainties and climate pressures surrounding investment in our energy transitions. The question is how fast, how much investment, and how to finance?

Needless to say, meeting our disparate energy needs as we transition towards a net zero world while making reasonable returns is particularly challenging for oil & gas producers, utilities, and burgeoning energy ventures. One bullish set of transition outlined by IEA, Rystad, the Hydrogen Council (table 2) describes an increasing role of green and blue hydrogen / ammonia (with carbon capture) in our industrial economies.

**Table 2: Possible Hydrogen Supply: Demand Mix**

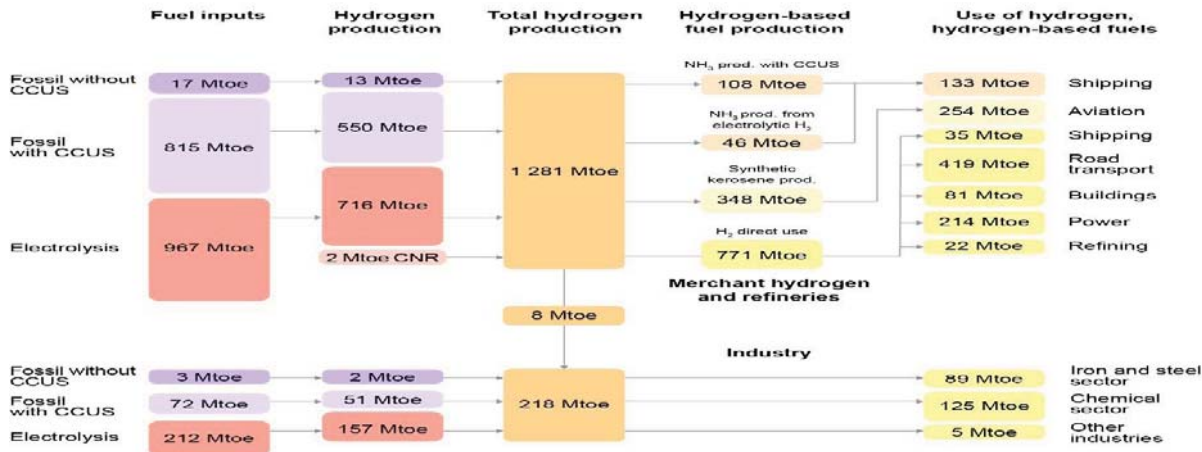
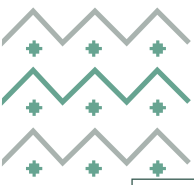


Figure 2 IEA Future of Hydrogen from 3

How Will Energy Suppliers Invest: Today's fossil fuel world which provides over 80% of energy supply is roughly divided into three stylized sets of producers with vastly different operating objectives, costs, resources (reserves), and management goals – Independent producers (IOCs), OPEC and National Producers (NOCs) + 1 (Russia), and shale producers.

Energy and the Environment



Each of these disparate group of producers, or agents, invests and produces with very different patterns that result in boom-bust investment cycles and varying degrees of production / supply flexibility. Given the shifts in our energy markets oil prices have been extremely volatile and hard to predict over the past fifty years (IEA, scenarios; VAR, Killian, Hamilton, et. al). Consequently, making long-term thirty-year investments where there is a tremendous commitment of capital, people, and uncertain returns is extremely challenging. The war in Ukraine, climate crisis, shale revolution, demand shift to Asia, and political upheavals are part our complex energy history (IEA, Yergin, The Prize, The Quest)

Is Hydrogen a Sustainable Opportunity? One of the critical questions is how will energy agents, with tremendous capital, engineering and technical expertise invest over the coming decades? What role will they play in our transition to a cleaner and more sustainable world economy.? And how might the dynamics of energy markets change? Are we stuck with boom-bust cycles, price volatility, and uncertain returns.

Today it appears that OPEC (Saudi Arabia) and some NOCs like Statoil are making significant investments in hydrogen / ammonia in their efforts to transform / anticipate our industrial economies. Middle Eastern (and North Sea) producers have access to abundance of low-cost gas, strong cash flows, carbon capture research / technology, and longer-term survival strategies. (figures 2 &3) Of course, the NOCs do not reveal the size, scale, economics, or technical details of their blue energy investments. However, we do know from various surveys (IEA, Hydrogen Council, Rystad, Royal Society) that we are talking about huge in investments in supply and infrastructure to move our economies to a more sustainable Hydrogen world

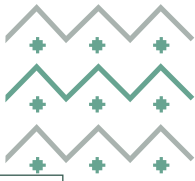
For example, steel and cement making need to be reconfigured away from coke and high energy / heat fossil fuels to hydrogen / ammonia, which also means that you must have a pipeline, shipping, and port infrastructure to handle such transitions. This requires a coordinated industrial policy involving producers, shipping / pipeline / transport players, ports / distribution centers, and manufacturing companies across different markets. Not an easy engineering or political task involving a myriad of parties.

#### Germany and Japan, making energy transition

The EU / Germany is reeling from the Ukraine war as everyone scrambles to replace Russian gas. The immediate push this winter is to LNG and gas from the Middle East suppliers and US, however Germany (Rotterdam) does not have the terminals to receive, convert, and distribute gas to the industrial sectors or its consumer. Building short term LNG terminals, also postpones investments by various players in the supply chain to cleaner, yet more expensive blue hydrogen. How to coordinate, build and finance Germany's transition from gas to hydrogen in light of Russian threats, and huge investments is daunting.

Japan's transition is no less urgent, however MITI and the government / private players have developed a long-term plan to move from nuclear following Fukushima to a gas and hydrogen economy. It has partnered with Aramco is using Ammonia ships to bring hydrogen to an energy isolate island economy. Japan's vitality also depends on its long-term energy sufficiency.





Each of these country case studies, shows the complicated non-linear adjustments to our shifting energy mix where suppliers have not fully developed the technologies, nor know the costs of supplying hydrogen. And the consumers / industries do not know the price, or the amount of investment required to build a more sustainable, secure, greener economy. With limited data we demonstrate how NOCs / OPEC may succeed – and make money -- in our decarbonized economies as we all navigate our volatile, messy worlds.

Selected References

1. Ammonia: zero-carbon fertilizer, fuel and energy store POLICY BRIEFING, The Royal Society, February 2020
2. Projecting Energy and Climate for the 21st Century, SERGEY PALTSEV, Economics Energy & Environment Policy, Vol 9, No.1
3. International Energy Agency (IEA), Future of Hydrogen 2019 and other reports
4. AlMehdar, Mohammed. "Imperfect OPEC: an Oil Market Model"
5. Ansari, D., F. Holz, and H. al-Kuhlani. 2020. "Energy Outlooks Compared: Different Methods, Different Futures." Economics of Energy & Environmental Policy, 9 (1)
6. Baumeister, Christiane, and Lutz Kilian. "Forty Years of Oil Price Fluctuations: Why the price of oil may still surprise us" Journal of Economic Perspectives, Winter, 2016
7. Hamilton, J.D. "Causes and Consequences of the Oil Shock of 2007-08," Brookings Papers on Economic Activity, 1, Spring 2009,
8. Pierru, Axel, James L. Smith, and Hossa Almutairi. 2020. "OPEC's Pursuit of Market Stability". Economics of Energy & Environmental Policy 9, 2020
9. Smith, James, L. Inscrutable OPEC? Behavioral tests of the cartel hypothesis. Energy Journal
10. Fattouh, B. (2006). "Spare Capacity and Oil Price Dynamics." Middle East Economic Survey 49
11. The Hydrogen Futures Simulation Model: Projecting Carbon Sequestration Costs SAND2004-4937(R), Thomas E. Drennen, William J. Kamery, and Peter H. Kobos
12. ENERGY SOCIETIES in 2050, Upstream report, RYSTAD ENERGY TRANSITION TRENDS, 2022







## How the Arabian Gulf Could Become the World's Clean Hydrogen Hub

*Dr. Kaushik Deb, Senior Research Scholar, Center on Global Energy Policy, Columbia University +1 9173288595, dk3208@columbia.edu*

*Abdullah Alshagiti, Columbia University, +1 9842683649, Abdullah.Alshagiti@columbia.edu*

### Overview

Hydrogen has received a lot of attention lately due to its potential for decarbonizing hard-to-abate sectors. Multiple countries in the Middle East have recently updated their Nationally Determined Contributions (NDCs) to the United Nations Convention on Climate Change (UNFCCC) to include more hydrogen. Two of these countries are the Kingdom of Saudi Arabia and the United Arab Emirates (UAE). The two largest members of the Organization of Petroleum Exporting Countries (OPEC) in the Middle East have shown keen interest in being leaders in the new hydrogen economy. Saudi Arabia has announced multiple hydrogen Giga-sized projects in the past two years. Saudi Aramco, the Kingdom's national oil company, also exported the first shipment of blue ammonia to Japan in 2020. Ammonia has been looked at as a long distance hydrogen transport method. UAE has announced its Hydrogen Leadership Roadmap during the 26<sup>th</sup> Conference of Parties to the UNFCCC (COP26). Due to their natural resources, gulf countries have immense potential to lead the global export of green and blue hydrogen.

This paper analyses how Gulf countries could utilise their natural resources and current oil and gas infrastructure to become global exporters of hydrogen. We specifically look at the following questions:

- How can some current natural gas facilities be coupled with carbon capture and storage to produce blue hydrogen?
- How can gulf countries use their current oil and gas infrastructure (pipelines, ports, oil and gas tankers) to export hydrogen?
- What are the economic and geopolitical implications of a transition towards hydrogen for the gulf countries?

### Methods

This paper provides an analysis of how gulf countries could benefit from the global transition towards hydrogen. A discussion provides an analysis of how current oil and gas infrastructure; including pipelines, ports, and oil and gas tankers; could be upcycled for hydrogen production and export. An exploration of the implications of Russia's invasion to Ukraine is provided, with a special emphasis on how some of the future European gas imports could be displaced with hydrogen from the Middle East.

### Results

Hydrogen can provide a solution that solves many climate and geopolitical challenges to both Europe and Asia. Gulf countries possess a tremendous amount of resources which can be utilised to export clean hydrogen to these markets.

The gulf has huge reserves of gas which can be used for the production of blue hydrogen. This gas is present in the eastern part of the gulf, which could facilitate the easy export of hydrogen to growing Asian markets. Ample cheap renewable energy (mainly wind and solar) is also present in the northwest side of the gulf. These resources could be utilised to produce and export green hydrogen to European markets.

Petrochemical companies' expertise in drilling could also be utilised in the production of renewable geothermal energy, which can be used to produce clean hydrogen.

### Conclusions

The Arabian Gulf region possesses both the geographical location and natural resources that could allow it to be a leader in clean hydrogen exportation.

### References

Global Hydrogen Trade to meet the 1.5°C climate goal: Trade outlook for 2050 and Way forward. IRENA International Renewable Energy Agency.

Nationally Determined Contributions Registry. (n.d.). <https://unfccc.int/NDCREG>





## TOTAL GREENHOUSE GAS EMISSION TRENDS AND PROJECTIONS IN THE EGYPTIAN ELECTRICITY SECTOR

Eng. Mostafa Hasaneen, RCREEE, +2 01007427646, mostafahasaneen@live.com  
Dr. Jauad El Kharraz, RCREEE, +20 102 302 99 01, jauad.elkharraz@rcreee.org  
Prof.Mahmoud Mohieldin, Cairo University, COP27 Champion

### Overview

A sustainable energy mix is developed by the Egyptian government to meet rising demand as well as to transition to a more ecologically friendly and varied electrical industry. The Egyptian electricity and renewable energy sector represent an influential factor in the proportion of carbon dioxide emissions, it counts as the largest proportion of national emissions by about 43.4% of the national greenhouse gases potential. This reflects the importance of the enhancing the climate change profile at the sector level through diversifying its energy supply and boost the amount of electricity generated from renewable sources, mainly wind and solar, because of the country's expanding domestic energy demand. The importance of renewable energy is emphasized in the 2035 Integrated Sustainable Energy Strategy [1] which builds on earlier policies. By 2035, Egypt plans to increase the percentage of electricity generated from renewable sources to 42%. In addition, a recent announcement for the climate change strategy up to 2050 includes five main goals, among these pillars, the first goal aims at magnifying energy efficiency through improving efficiency of thermal energy stations, distribution networks and activities related to oil and natural gas [2]. The research paper provides a full analysis of the trends during the period (1990 - 2018) and the projections of emissions up to 2035 for the Egyptian electricity sector. The methodology used an advanced software tools aiming to provide an overview figure for the effect of the new sustainable projects on the country's updated NDC [3]. This will help to prioritize the upcoming projects with the possibility of effectively managing financing needs and provides number of scenarios to identify country needs, as well as filling the gaps needed in the international obligations either technically or politically in the future.

### Methods

The paper advances two internationally accredited software tools for calculating GHG emissions. The first software used is the official IPCC software to provide a review of the status of emissions where the trends of the emissions from the electricity sector were calculated starting from 1990, which is the base year for calculating emissions internationally [4], [5]. A comparison was made between the performance of the various electricity production companies during the previous years (2008-2018), considering the emission factor (grams / kilowatt-hours) for these companies.

The second tool is the statistical simulation models (R studio), which used in predicting the future emissions of the electricity sector [6], [7]. Two prediction modes were made to test the accuracy of the models by calculating the coefficient of change (R2), and the most accurate model was chosen, where the future emissions were predicted through a set of scenarios. The first Scenario, where the study was applied to the most likely scenario of the Energy Strategy 2035 (4b). The second scenario introduces the ratios of coal-generated capacities were transferred to the ratios of thermal generation, while maintaining the same ratios of renewable energies and nuclear energy expected in the likely scenario of the Energy Strategy 2035. The third scenario advances half of the proposed capacity to be generated from coal which transferred to the generation ratios from renewable energies, and the other half was transferred to the ratios to thermal capacity, while maintaining the same percentages of nuclear energy expected in the likely scenario of the energy strategy 2035 [8]. The Final scenario transfers the proposed capacities to be generated from coal completely to the expected generation rates from renewable energies, while maintaining the same ratios of thermal generation and nuclear energy expected in the likely scenario of the energy strategy 2035.

### Results

The analysis of the trends of the emissions generated by the Egyptian electricity sector increased from 23.5 million metric tons of carbon dioxide equivalent in 1990 to 100 million metric tons of carbon dioxide equivalent by the year 2018. In addition, an increase in the efficiency of operation of electricity produced from the Egyptian production



plants, and the largest decrease in the fuel consumed was reached for the Middle Delta Electricity Production Company, where the emission factor decreased from 0.62 to 0.51 (gram/kilowatt hour) during the period (2008 – 2018). For the results of the analysis of projections of the future expected emissions according to the raised scenarios. The first scenario results came with the expectation that the electricity sector emissions for this scenario would reach about 130 million metric tons of carbon dioxide equivalent in 2035. The results of the second scenario came with an expectation that the percentage of electricity sector emissions for this scenario would reach about 100 million metric tons of dioxide. carbon equivalent. The third scenario shows that the electricity sector emissions percentage would reach about 70 million metric tons of carbon dioxide equivalent in 2035. While about 20 million metric ton of carbon dioxide equivalent, could raises from the final scenario which is the lowest possible percentage of emissions, given the total dependence on clean energies in this scenario, amounting about 83% of the total energy produced in 2035.

## Conclusions

The research paper sheds the light on the climate change profile and its importance at the international and regional levels. It helps in satisfying the obligatory reports and contributions for Egypt to be submitted to field of climate change, this study reviews how to fulfil these reports in line with the requirements of the United Nations Framework Convention (UNFCCC). The paper focuses on the past and future emissions for the Egyptian electricity and renewable energy sector, which provides the opportunity to prioritize projects during the coming period, with the possibility of managing funding needs effectively, and provides the opportunity to identify weaknesses in the climate change profile either on the strategic or the implementation phase. In addition, the paper provides overview scenarios for the implementation of low emissions actions in Egypt during the upcoming years. These results will pave the way for investors and developers to be more confident towards a low emission long-term action plan in the electricity sector. The paper considers maximizing technological advancement and expanding financial benefits of renewable energy sources in the next decade.

## References

- [1] EEHC: Egyptian Electricity Holding Company Annual Report 2020, [http://www.moee.gov.eg/english\\_new/report.aspx](http://www.moee.gov.eg/english_new/report.aspx)
- [2] EEAA: Egyptian Environmental Affairs Agency (EEAA), <https://www.eeaa.gov.eg/portals/0/eeaaReports/N-CC/EgyptNSCC-2050-Summary-En.pdf>
- [3] UNFCCC: United Nations Framework Convention on Climate Change, <https://unfccc.int/sites/default/files/NDC/2022-07/Egypt%20Updated%20NDC.pdf.pdf>
- [4] IPCC , Intergovernmental Panel on Climate Change, special report on the impacts of global warming of 1.5 °C , <https://www.ipcc.ch/sr15/>
- [5] GFDRR, Global Facility for Disaster Reduction and Recovery, <https://www.worldbank.org/en/news/press-release/2018/05/08/new-report-looks-at-past-disasters-to-prepare-for-the-future>
- [6] Future Resilience of the UK Electricity System, AN ENERGY RESEARCH PARTNERSHIP REPORT, November 2018.
- [7] U.S. Carbon Dioxide Emissions in the Electricity Sector: Factors, Trends, and Projections, Congressional Research Service, 2019.
- [8] State of the Environment, Report issued by the Environmental Affairs Agency, Ministry of Environment, 2019.



## ***CARBON NEUTRALITY OF OIL MAJORS – CURRENT STATUS, TARGETS, AND ECONOMIC RATIONALE***

[Matthias J. Pickl Ph.D., Saudi Aramco, +966 13 873 3908, matthias.pickl@aramco.com]

### **Overview**

Following the Paris Agreement and its climate goals, oil companies have faced increased pressure from stakeholders to act on environmental issues. This paper quantifies the emissions of the eight oil majors, investigates their commitments for emission reductions, and models the impact of a potential carbon price on their profitability and market capitalization. Preliminary analysis shows that between 2011 and 2020, all oil majors have reduced their scope 1 and 2 emissions and intensity. Furthermore, two-thirds of the oil majors have committed to becoming net-zero emission businesses in the long term. A strong influence of the companies' region of incorporation is observed, with European oil companies implementing pathways towards carbon neutrality faster, whereas American oil companies remaining laggards in terms of GHG reductions, commitments to sustainability and the energy transition. Finally, the paper seeks to quantify that this commitment towards emissions reduction is pursued following an economic rationale: the potential introduction of a carbon price of USD 50 per tonne, USD 100 per tonne, or USD 250 per tonne to the emissions of oil majors could reduce their profitability significantly, thus impacting their market capitalization.

### **Methods**

Based on a detailed literature review, the following hypotheses are formulated and will be tested through the outlined methodology:

Hypothesis 1a: Oil Majors are reducing their Scope 1 and 2 Global GHG emissions over the last ten 10-year period (2011 to 2020).

In order to test this hypothesis, it is proposed to establish the scope 1 and scope 2 Global GHG emissions by the eight oil majors both in terms of total number of scope 1 and scope 2 GHG emission and in terms of GHG intensity per MBOE from 2011 to 2020. The total number of GHG emissions of the respective oil major and the associated GHG intensity per MBOE (based on the total production of oil and gas) will be calculated as follows and assessed for every year in the evaluation period:

- (1) Total Number of GHG Emissions =  $\sum$  Scope 1 Emissions + Scope 2 Emissions
- (2) GHG intensity per MBOE = (Total Number of GHG Emissions  $\times$  1000) / (Production in MMBOE)

Hypothesis 2a: European Oil Majors are achieving higher reductions in their Scope 1 and 2 Global GHG emissions over the last ten 10-year period (2011 to 2020) compared to American Oil Majors.

To examine this hypothesis, the average reduction in GHG emission and GHG intensity over the last ten 10-year period (2011 to 2020) by all European Oil Majors is compared to average reduction in GHG emission and GHG intensity by all American Oil Majors. Thus, earlier research findings that show an effect of the companies' region of incorporation on energy transition efforts will be tested to assess whether European oil companies are implementing pathways towards carbon neutrality faster than American oil companies.

Hypothesis 3a: Oil Majors are showing commitment to climate change actions and long-term carbon neutrality.

To assess this hypothesis, the published Environmental, Social, and Governance (ESG) and carbon neutrality targets by the oil majors are empirically evaluated and discussed to determine their overall commitment to becoming net-zero emission businesses in the long term. Particularly it will be assessed whether oil majors have committed to Scope 1 and 2 Net Zero Emission Targets and Scope 3 Reduction Targets; have specific renewable electricity targets in place; have established energy efficiency policies; have announced emission reduction initiatives; have set up climate change policies; and have discussed the risks of climate change and have started to address its mitigations. A "yes" to the majority of these questions would provide support for the above stated hypothesis 3a.

Hypothesis 4a: The Oil Majors' commitment towards emissions reduction is pursued following an economic rationale.



To test this hypothesis, the impact of the potential introduction of different sets of carbon prices on the oil majors' cost position, Earnings before Interest, Taxes, Depreciation, and Amortization (EBITDA), and market capitalization is modelled. For the purpose of this analysis, it is assumed that the impact of a CO<sub>2</sub> price is tied to direct (scope 1 and 2) emissions, that costs for such emissions will be borne by the emitter (i.e., the oil companies), that buying CO<sub>2</sub> permits is the chosen market responses by the oil companies (or that alternative responses such as investing in lower emissions businesses and switching to carbon neutral technologies would lead to similar costs), and that the timing of the application of the carbon tax is in line with the IEA Net Zero by 2050 Roadmap. Furthermore, Earnings before Interest, Taxes, Depreciation, and Amortization (EBITDA), the standard multiple for valuations, is used as a proxy for profitability to better compare across the oil majors as this metric is normalized for differences in capital structure and taxation. EBITDA multiples generally tend to yield better estimates than EBIT multiples. The impact on profitability and market capitalization is modelled as follows:

- (3) Cost Impact = Total GHG Emissions Scope 1 and Scope 2 × Carbon Price
- (4) Adjusted EBITDA = EBITDA (5-year average) - Cost Impact
- (5) Revised Market Cap = Adjusted EBITDA × EBITDA Multiple

## Results

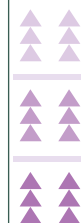
Preliminary analysis shows support for most of the hypotheses. Detailed results will be presented at the conference.

## Conclusions

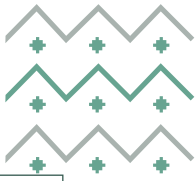
This paper aims to quantify the GHG emissions of the eight oil majors – Royal Dutch Shell, ExxonMobil, Chevron, TotalEnergies, BP, Eni, Petrobras, and Equinor – to ascertain whether oil majors are reducing their Scope 1 and 2 Global GHG emissions over the last ten 10-year period, and to assess the commitments the eight oil majors have announced to reduce these in future. Furthermore, the paper set out to model the impact of different sets of carbon dioxide prices on the profitability and market capitalization of the oil majors, to determine whether the oil majors' commitment towards emissions reduction is pursued following an economic rationale. The majority of hypotheses found support by preliminary empirical analysis. Further research may focus on how oil companies should reach carbon neutrality over time, assessing the trade offs between divesting, reducing existing emissions, and developing less carbon intensive businesses. GHG reductions need to be assessed within several oil business-related activities (drilling, flaring, production, venting, processing, and liquefaction) while also considering the special challenges different regions face. Overall, the energy transition towards carbon neutrality may represent the biggest challenge in the corporate strategy of oil majors and deserves further research.

## References (selected)

- Daniel, K. D., Litterman, R. B., Wagner, G. (2019). Declining CO<sub>2</sub> price paths. Proceedings of the National Academy of Sciences, 116 (42), 20886-20891. <https://doi.org/10.1073/pnas.1817444116>.
- Brewer, J., Rodger, A., & Rooney, I. (2021). How to decarbonise the upstream industry. Wood Mackenzie. Nov 14<sup>th</sup> 2022. <https://www.woodmac.com/reports/upstream-oil-and-gas-how-to-decarbonise-the-upstream-industry-491936>.
- Gillan, S.L., Koch, A., & Starks, L.T. (2021). Firms and social responsibility: A review of ESG and CSR research in corporate finance. Journal of Corporate Finance, 66, 101889. <https://doi.org/10.1016/j.jcorpfin.2021.101889>.
- IEA (2021). Net Zero by 2050: A Roadmap for the Global Energy Sector. International Energy Agency, Paris. Retrieved May 20, 2022 from: <https://www.iea.org/reports/net-zero-by-2050>.
- Johnston, R.J., Blakemore, R., & Bell, R. (2020). The role of oil and gas companies in the energy transition. Atlantic Council. Retrieved November 20, 2022 from: <https://www.atlanticcouncil.org/wp-content/uploads/2020/07/OGT-final-web-version.pdf>.
- Lie, E., & Lie, H.J. (2019). Multiples used to estimate corporate value. Financial Analysts Journal, 58, 44-54. <https://doi.org/10.2469/faj.v58.n2.2522>.
- Pickl, M. (2021). The trilemma of oil companies. The Extractive Industries and Society, 8/2, 100868, <https://doi.org/10.1016/j.exis.2021.01.003>.
- Pickl, M. (2019). The renewable energy strategies of oil majors – From oil to energy?. Energy Strategy Reviews, 26, 100370, <https://doi.org/10.1016/j.esr.2019.100370>.
- WRI (2015). The Greenhouse Gas Protocol: A Corporate Accounting and Reporting Standard, Revised Edition. World Resources Institute: Washington, DC, USA. <https://ghgprotocol.org/sites/default/files/standards/ghg-protocol-revised.pdf>.







## *MATERIAL TRANSITION IN AN ENERGY TRANSITION WORLD*

[Samuel Liew Loong Wei, Saudi Aramco, 0138730223, Samuel.liew@aramco.com]  
[Mohammed A Abusham, Saudi Aramco, 013-8744517, mohammed.abusham@aramco.com]

### **Overview**

Material transition plays on the petrochemical industry role as carbon transformer into valuable end-consumer products, such as wind turbine, solar panels, housing insulations and transportation vehicles. It focuses on the "carbon vault" potential of petrochemical products and also as an enabler of a low-carbon solutions. The "carbon vault" describes not only the role in achieving energy-saving solution but also the benefit of storing carbon in long life end-consumer products. For example, for every ton of GHG emitted by the global chemical industry its products and technologies enable over 2 ton of GHG emissions savings. However, if this is coupled with further emission policies, GHG emissions savings enabled by the chemical industry could increase to over 4 ton for every 1 ton of emissions by 2030 . Even recovered plastics can be used in other applications such as construction materials for road and pavements.





## **FORECASTING THE RATE OF COST REDUCTIONS IN BLUE AND GREEN HYDROGEN**

Anders Norlen, Saudi Aramco, +96655-136-7618, anders.norlen@aramco.com

### **Overview**

Hydrogen has been described as an energy carrier suited for decarbonization of hard-to-abate-sectors such as high-heat industrial processes, aviation and marine shipping. The low-carbon hydrogen options have broadly been described as (i) green hydrogen derived from electrolysis with electricity from renewable sources or (ii) blue hydrogen which is derived from steam reformed natural gas paired with carbon capture and storage ("CCS"). The relative role of green and blue hydrogen in the energy transition can be described as their respective abilities to see costs compressed over time. This paper aims to look at the different cost components in green and blue hydrogen to analyze the cost compression potential of different components that drive levelized cost of hydrogen ("LCOH") out to 2030 and beyond.

### **Methods**

Comparison of bottom-up- and top-down cost development drawn from analogies across industries. The conclusions will be compared and then further analysed to draw relevant conclusions around the most likely winner in the technology race in the energy transition.

### **Results**

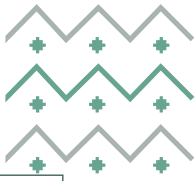
Yet to be determined.

### **Conclusions**

Yet to be determined

### **References**





## Saudi Arabia's Aviation Sector Ambitions and Potential Pathways for Decarbonizing the Sector

David Omom, Saudi Aramco, +966 13 873 5801, [david.omom@aramco.com](mailto:david.omom@aramco.com)  
Muhammad Akmal, Saudi Aramco, +966 13 874 6076, [muhammad.akmal@aramco.com](mailto:muhammad.akmal@aramco.com)

### Overview

Saudi Arabia recently announced its National Aviation Strategy which seeks to transform the Kingdom in to a global aviation hub, in line with the government's economic diversification plans and ambitious tourism targets. The strategy aims to more than triple annual passenger throughput from 103 million in 2019 to 330 million; increase air cargo throughput from 0.7 million tons in 2019 to 4.5 million tons; and improve the Kingdom's city-to-city direct connectivity from 151 to over 250 – all by 2030.

The underlying goal is to increase employment in the sector from 0.3 to 1.1 million and annual GDP creation from \$21 billion to nearly \$75 billion by 2030. To this end, the government aims to invest around \$97 billion, of which up to \$79 billion is expected to come from the private sector.

Using publicly available data, we have modelled the implications of these targets on airline capacity and throughput; on jet fuel demand and on greenhouse gas (GHG) emissions.

### Methodology

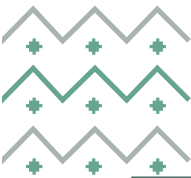
The study employs a two-stage analytical framework. First, the forecasts of passenger throughput and passenger-kilometers for domestic, international and transit segments are developed as a function of population and GDP as well as tourism targets and airline strategies. At the second stage, taking travel forecasts as exogenously given, the projections of fuel demand and supply requirements as well as GHG emissions are prepared at a granular level.

Most of the data/information is obtained from public sources, including from Saudi Arabia's General Authority of Civil Aviation and the Ministry of Transport and Logistic Services. The paper also utilizes Saudi Aramco's internal projections of population and GDP for Saudi Arabia. In the results, passenger throughput is presented in form of airline format (origin to destination) data rather than the alternative airport format (origin plus destination) count, that is the basis of the target.

### Results

Under the National Aviation Strategy, total passenger throughput grows three-fold from 76 million in 2019 to 251 million by 2030. Representing almost a third of overall traffic, domestic passenger throughput increases from 27 million passengers in 2019 to 79 million passengers by 2030. Over the same period, international traffic grows from 46 million to 142 million passenger while international transit throughput grows almost 10-fold to 30 million passengers by 2030. Fulfilment of these targets offers a generational opportunity to expand Saudi airlines. Indeed, the traffic carried by Saudi registered airlines rises nearly four-fold to 171 million by 2030, split between Saudia, Flynas and Flyadeal as well as the two new PIF-funded airlines (RIA and NEOM).

Saudi Aramco: Company General Use



Underpinned by the anticipated sharp growth in air travel, the demand for aviation fuels is seen to increase from 88 thousand barrels per day (MBD) in 2019 to 305 MBD by 2030. Fuel consumed by domestic and international flights in Kingdom is estimated at a lower 164 MBD, of which domestic flights account for around 20 MBD. Similarly, GHG emissions from the aviation sector are projected to increase from 17 carbon dioxide-equivalent megatons (MtCO<sub>2</sub>-e) in 2019 to 45 MtCO<sub>2</sub>-e by 2030. In line with this overall emissions trajectory, GHG emissions from the operations of Saudi registered carriers are projected to reach 25.8 MtCO<sub>2</sub>-e by 2030 (15.5 MtCO<sub>2</sub>-e on international flights). Of the international footprint, a third will need to be offset under the Carbon Offsetting and Reduction Scheme for International Aviation framework developed by the International Civil Aviation Organization. These volumes are expected to increase sharply beyond 2030. An ongoing revision of the paper extends the time frame of analysis to 2060 where the trade-offs between sustainable aviation fuels, traditional jet fuel and offsets are much sharper.

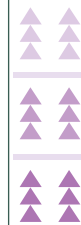
### Conclusions

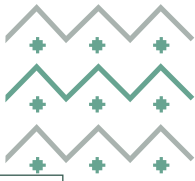
The recently announced National Aviation Strategy by Saudi Arabia aims to increase the air passenger throughput more than three-fold to 330 million by 2030. If implemented successfully, the strategy will transform the aviation sector into a major source of employment and value creation, with total workforce numbers exceeding 1.0 million by 2030. The consequent surge in the demand for aviation fuels will however pose considerable decarbonization challenges in the face of an increasingly carbon constrained environment, both domestically and internationally. To better understand the true scale of the challenge and study alternative decarbonization options, the outlook horizon is currently being extended to 2060, broadening also the fuel coverage to include bio- and synthetic fuels.

### References

- Ministry of Transport and Logistic Services (2022), Introducing the Saudi Aviation Strategy, Future Aviation Forum, Riyadh, 9-11 May 2022  
[https://futureaviationforum.storage.googleapis.com/media/documents/SAS\\_FAF\\_Brochure\\_V3.pdf](https://futureaviationforum.storage.googleapis.com/media/documents/SAS_FAF_Brochure_V3.pdf)
- ICAO Secretariat (2022), ICAO Regional Workshop on CORSIA, Session 6: CORSIA Offsetting Requirements, <https://www.icao.int/>.
- GACA (2022) Open Data, Airport Air Traffic Data for 2010-2020. [https://gaca.gov.sa/web/ar-sa/content/translation-of-ar-sa-open-data-library\\_41148](https://gaca.gov.sa/web/ar-sa/content/translation-of-ar-sa-open-data-library_41148)
- Graver, Brandon (2018). Does it Matter to Your Carbon Footprint Whether You Are Flying Across the Atlantic or the Pacific? International Council on Clean Transportation (ICCT) Blog. <https://theicct.org/>
- General Authority for Statistics (2020), *55th Statistical Yearbook: 2019*, Chapter 17. Tourism, Entertainment and Sports
- GOV.SA (2021), Tourism Strategy in Saudi Arabia, <https://www.my.gov.sa/wps/portal/snp/aboutksa/tourism>
- World Tourism Organization (2020). Compendium of Tourism Statistics dataset (Electronic). Saudi Arabia Basic Indicators Country Report
- Saudi Aramco (2022). Population and GDP forecasts.

Saudi Aramco: Company General Use





## [THE CONSEQUENCE OF ELECTRIFICATION OF ROAD VEHICLES FASTER THAN THE TRANSITION IN THE POWER SECTOR]

Mohd Rahman, Saudi Aramco, +96613-874-5199, mohd.rahman@aramco.com

### Overview

According to Bloomberg New Energy Finance (BNEF), there are now almost 20 million passenger electric vehicles (EVs) on the road. In recent quarters, the increase in EVs sales showed impressive growth. Similarly, nations around the world have announced targets to limit internal combustion sales. Electrification is also expected to reach other transport subsectors including trucks. Thus, demand for electricity arising from the road transportation sector can be large, which at present account for almost one-third of total energy related CO<sub>2</sub> emissions. There is a credible risk that emissions from the power sector amid slow transition can outweigh the saved emissions from the transportation sector if electrification accelerates. In such scenarios, efficient light-weight ICE vehicles can alternatively help into a smooth transition.

### Methods

Detailed bottom-up analyses of country specific forecasts on EVs penetration at different levels against different transition paces in the power sector will be compared. These scenarios will then be compared against alternative routes of co-development of EVs and highly efficient and low-cost ICEs to demonstrate a pragmatic transition that is fit for all sectors.

### Results

Yet to be determined.

### Conclusions

Yet to be determined

### References

Saudi Aramco: Company General Use







## ROADMAP FOR SMART ENERGY SOLUTIONS TO REACH A SUSTAINABLE AND SECURE ELECTRICITY SUPPLY IN EUROPE

Dr. Philipp Riegebauer; Centre of Innovative Energy Systems, University of Applied Sciences, Dusseldorf, Germany; BABLE Smartcities GmbH, Stuttgart, Germany; Phone: +49 151 5858 1648, E-Mail: philipp.riegebauer@hs-duesseldorf.de

### Overview

There is a need for major transformations in the energy system and a greater sense of urgency to reach the climate goals. Twenty-first century technologies offer new possibilities for the future of cities. However, the current pace at which these disruptive technologies proliferate rapidly increase, faster than what city leaders could keep up with. Cities need a clear and comprehensive vision to shape their smart energy future, one that is ambitious, grounded to reality, and that leverage unique local assets.

Digitalization offers countless answers and solutions to the increasing challenges of sustainable energy supply. The need for suitable technologies, processes, and business models to cope with the major transformations in the energy system is increasing worldwide. This is due to ongoing megatrends such as urbanization, connectivity, and security. These measures are also intended to counter current crises such as pandemics, energy security and import dependency, climate change and structural change.

One objective is to find out whether there is an intrinsic micro-economic benefit for cities/regions to implement smart energy technologies to enable a shift to carbon-neutral energy consumption. This holds great promise for addressing the vexing challenge of cities to develop a path to carbon-neutrality. This work will envisage a clearer view of the future's potential of the city as well as the today's city-specific challenges.

### Methods

The paper introduces a practice-oriented systematic to identify major technological milestones to reach sustainability goals with consideration of city specific circumstances. Reflecting their CO<sub>2</sub>-reduction potential the work identifies key technologies, outlines major development milestones, and prioritizes technologies based on their potential to be implemented and upscaled in a particular city/region.



Figure 1: Four action lines of the BABLE decarbonization systematic

The four action lines of the applied systematic guarantee a holistic and sustainable approach to decarbonize the energy system. The paper and presentation will focus on the technology transfer matrix (1), development of the scale-up roadmap (2) and introduce an example of the government decision support model (4).

The main objective of the transfer matrix is to visualise the assigned rating for each technology based on the described criteria.

For the concept of the scale-up roadmap, the technologies are evaluated based on a Multi-Criteria Assessment (MCA). This analysis highlights the city-specific potential for technologies to decarbonize the energy system considering several key criteria co-identified with the city/region.

Five different sectors for smart energy solutions are analyzed to reflect interdependencies and sector coupling effects:

- Renewable and sustainable energy transition
- Digital & transmission infrastructure
- Balancing and storage
- Climate-neutral end use & energy efficiency
- Sustainable mobility

		Renewable and sustainable energy generation						
		Biomethan	Mini-CHP for decentral solutions	Solar thermal generation	Biomass	Wind	Roof-top PV	Large-scale PV
Technology Criteria	Development status	Low	Low	High	Very High	High	High	High
	Conversion efficiency	Medium	Medium	High	Medium	High	Medium	Medium
	Technology potential	Very high	High	High	Medium	High	Very high	Very high
Environmental Criteria	Environmental friendly impact	Medium	Medium	High	Medium	High	High	High
	Public acceptance	Very high	High	Very high	High	Medium	Very high	Very high
Economic potential	Status-quo	Low	Low	High	High	Medium	Medium	Medium
	2050	Medium	Medium	High	Medium	High	High	Very high

Figure 2: Example for the technology transfer matrix

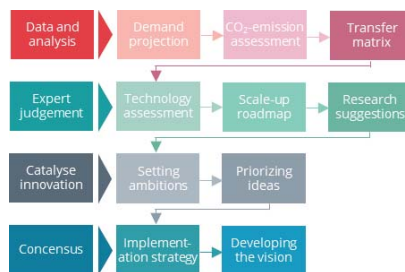
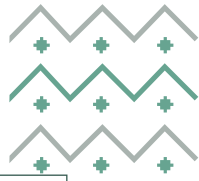


Figure 3: Multi-Criteria Assessment (MCA) for technology evaluation



A cross-sectoral innovative approach is applied to identify the sectors with highest decarbonization potential based on city/region specific circumstances. E.g., the focus to intermittent renewable energy sources of wind and photovoltaics as the main pillars of future electricity generation in Europe comes along with distinctive challenges for technical and market integration. A key issue is to find reasonable use for excess intermittent renewable electricity generation. Hourly specific spread patterns for 22 years for diverse applications in three sectors are processed. For the industrial sector green hydrogen generation and energy efficiency improvements are possible considerations for technology scale-up. For residential and commercial sectors technologies such as building retrofitting, and investments in solar thermal and PV-generation are evaluated.

The introduced methodology of the market analysis demonstrates how the country specific landscape – constituted by market leaders, best-practices, innovation networks and funding instruments - would be decisive to have mass-market adoption of digital energy technologies in the energy system.

### Results

The results of the smart energy scale-up roadmap are based on data of a major German city. First a technology transfer matrix (1) is applied, rating available sustainable technologies based on city specific circumstances. For each technology, specific milestones and tipping-points are identified until 2050. Macro-economic consequences and market interaction effects between investigated technologies and sectors are stated. Tangible next steps that need to be undertaken for further scale-up are acknowledged. The smart energy scale-up roadmap (2) demonstrates how investments in research, pilot projects, policy updates and infrastructure in the short and medium-term would be decisive to have mass-market adoption of the technologies in the long-term in a city specific environment.

However, city administration often indicates they have limited capacity and internal structure is not ready for increasingly rapid technologies cycles. To enable city leaders to keep up with disruptive and complex technology a government decision model (4) is introduced. Using a comprehensive up-to-date platform an overview of the full market landscape of use-cases, solutions and products is given. A factsheet review of the market landscape and where technologies have been implemented in the past is done together with city representatives. The city administration refines the scope and makes the decision on best suitable solutions. This is based on the results of the decarbonization roadmap as well as the terms of reference for the procurement method (3) that fits them best. These steps will be presented based on a current project which has proven to accelerate decision making in city administration and help to distribute task to relevant departments overcoming silo thinking.

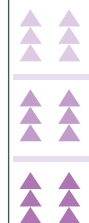
### Conclusions

To achieve the ambitious climate and carbon emission goals, in addition to major infrastructural investments, bottom-up innovations an early engagement of the local ecosystem are crucial. Measures in the energy, building and mobility sectors must significantly reduce carbon emissions immediately. One policy-relevant conclusion is that government intervention has to reach an optimal level to incorporate social limitations of their decarbonization roadmap e.g., address the burden of low-income households. The development of a smart energy scale-up roadmap must bring not only the citizens primary beneficiaries together, but also relevant research and industry partners. In this context, a disruptive development can begin, when some specific digital applications (e. g. ICT, open data, data platforms, security technologies, artificial intelligence, IoT) with relevance to the energy systems become standards.

### References

- Riegebauer et al. (2022) 'Market and industry innovation study in the field of smart city and sustainable buildings'; Cluster Agentur Baden-Württemberg, Ministry of Economy, Labour and Tourism of Baden-Württemberg. pp. 1-79
- Oesterwind, Riegebauer (2022) 'Paths to a Climate-Neutral Future – the Citizens Decide on its Success'; Energy Forum, International Association for Energy Economics. Q1(2022); pp. 30 – 33, Issn 1944-3188, [http://www.iaee.org/documents/EF221\\_full.pdf](http://www.iaee.org/documents/EF221_full.pdf)
- Marius Reich, Jonas Gottschald, Philipp Riegebauer and Mario Adam (2020) 'Predictive Control of District Heating System Using Multi-Stage Nonlinear Approximation with Selective Memory'; Responsible for 'Impact of District Heating Networks on Local Electricity Grids'; Energies; Special Issue Modeling and Control of Smart Energy Systems; 13(24), 6714; <https://doi.org/10.3390/en13246714>





## ***POTENTIAL FLY ASH UTILIZATION FOR CONCRETE ADMIXTURE AND CARBON CAPTURE TECHNOLOGY FROM BIOMASS-COAL CO-FIRING POWER PLANT IN INDONESIA***

Rachmat Hermawan, State Electricity Company (PLN), Indonesia, +62-81333038087, rachmath2387@gmail.com  
Muhammad Idris, State Electricity Company (PLN), Indonesia, +62-8121954196, muhammad.idris@pln.co.id

### **Overview**

Indonesia's Government has a commitment to mitigate climate change by setting targets for emission reduction and Net Zero Emission (NZE) by 2060. The roadmap has been established with a target of 23% renewable energy mix and should be achieved by 2025 (MEMR 2021). According to the Ministry of Energy and Mineral Resources (MEMR), biomass reserves in Indonesia have a total potential of 43.211 GWh per year (Kuvarakul et al. 2015). In this case, PLN as Indonesia State Electricity Company is committed to support the realization of targets by utilizing biomass. To support this target, PLN has program to use a mixture of biomass with coal (biomass-coal cofiring) for existing coal fired power plant (CFPP) in 52 locations.

Biomass has advantages as a substitute for fossil energy. Some of these advantages include: biomass can reduce the greenhouse effect, reduce organic waste, protect water and soil cleanliness, reduce air pollution, and reduce acid rain and acid fog. Biomass feedstock usually has to be converted in various ways into solid, liquid, or gaseous fuels that can be used to provide heat energy or generate electricity (European Parliament and the Council 2005).

Cofiring CFPP produces fly ash as a product of burning coal-biomass. The utilization of fly ash gives positive impact on landfill space and also encourage global emission reduction. Several studies have been done related to the performance of reinforced concrete containing fly ash and recently about the utilization fly ash in carbon capture technology (Balachandra et al. 2021).

The objective of this study is to analyze the characteristics of fly ash with the variation of biomass from cofiring CFPP and find out the potential fly ash utilization based on its characteristics.

### **Methods**

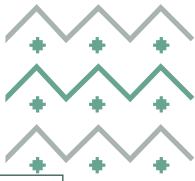
Five different biomass of power plants are investigated in this research, such as woodchips, sawdust, Palm Kernel Shell (PKS), rice husk, and corn cobs. The literature review is applied for the methods in this paper. Recent numerous studies and literatures are investigated. A three-step approach was followed to investigate fly ash utilization for concrete admixture and carbon capture:

1. Investigation of fuel characteristic (coal and biomass) and fly ash analysis from each power plant.
2. Comparison of fly ash analysis with standard ASTM C618 and review of the recent FA utilization studies for cement admixture. A carbonation test with phenolphthalein pH indicator is conducted to confirm the depth of carbonation in concrete visually after immersion in NaCl 3.5% solution.
3. Characterization of fly ash with Scanning Electron Microscope (SEM) and review from the recent studies of fly ash utilization for carbon capture from each power plant.

### **Results**

1. Chemical compositions of fuel and fly ash are mainly affected by the characteristic of biomass, coal and boiler technology.
2. Based on ASTM C618 requirement, power plant that used PKS, and rice husk as biomass could be used for pozzolanic material as F Class. These several biomasses are very potential to be developed in Indonesia due to abundant natural resources.





3. All of the fly ash characteristics from cofiring have a potential development and research for carbon capture to give alternative sorbent material besides amine. Due to the round shape of fly ash, it becomes a porous material as shown in SEM results. Porous materials give a better adsorption characteristic and have stable metal oxides, like  $\text{Al}_2\text{O}_3$ ,  $\text{SiO}_2$ , and,  $\text{CaO}$ .

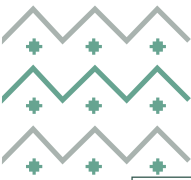
## Conclusions

CFPPs are still the main role in electricity generation in Indonesia. Biomass-coal cofiring as a strategic program, has potential to support the renewable energy mix target of 23% in 2025. Fly ash utilization as solid waste for cement admixture and carbon capture, able to reduce landfill of fly ash and emission reduction to achieve NZE by 2060.

## References

- Balachandra, Anagi M., Nastaran Abdol, A. G.N.D. Darsanasiri, Kaize Zhu, Parviz Soroushian, and Harris E. Mason. 2021. "Landfilled Coal Ash for Carbon Dioxide Capture and Its Potential as a Geopolymer Binder for Hazardous Waste Remediation." *Journal of Environmental Chemical Engineering* 9 (4). <https://doi.org/10.1016/j.jece.2021.105385>.
- European Parliament and the Council. 2005. "Communciation from the Commission: Biomass Action Plan." *Biomass*, 1–47.
- Kuvarakul, Thachatat, Alin Pratidina, Diane Anggraeni, and Hasintya Saraswati. 2015. "Renewable Energy Guideline on Biomass and Biogas Power Project Development in Indonesia," no. February: 204.
- MEMR. 2021. "Rencana Usaha Penyediaan Tenaga Listrik (RUPTL) PT PLN (Persero) 2021-2030." *Rencana Usaha Penyediaan Tenaga Listrik 2021-2030*, 2019–28.





[PAPER/POSTER TITLE]

## Heat insulation of buildings in Amman and its impact on energy saving and comfort for the Residents

Abdel-Fattah, A. N.<sup>1,\*</sup>, Sbeih, S. H.<sup>2</sup>, Ayadi, O.<sup>3</sup>

<sup>1</sup> Water Food & Energy for Env. Res. Mgmt. Co. (Al-Makan for Environmental Consulting), P. O. Box 2736 Jubieha Area, Amman 11941, Jordan

<sup>2</sup> Department of Statistics (DOS), Ministry of Planning & International Cooperation (MoPIC), 30 Yajouz St, Jubieha Area, Amman, Jordan

<sup>3</sup> Mechanical Engineering Department, The University of Jordan, Amman 11942, Jordan

### Overview

#### ABSTRACT

*A significant proportion of residential apartments in Jordan are affected by moisture problems, mold growth on walls and thermal discomfort. These problems are mainly related to poor wall thermal insulation and lack of building quality control. The aim of this work is to quantify the percentage of thermally insulated buildings in Jordan, and to identify gaps in building codes enforcement system in order to inform policy makers and recommend remedy measures. A carefully designed questionnaire-based field survey was done for 500 residential apartment units in Amman, the questionnaire was aided with a ground-truthing Infrared Screening (IR) for building's envelopes to check the validity of answers in the filled questionnaires. Main findings of this work showed that only 5.8% of the 500 surveyed residential apartment units in Amman had thermal insulation. This unexpected result, not in line with the country's energy efficiency, climate, green buildings, and environmental plans. As a result of the recommendations from this research, a new regulatory and procedural changes underway from entities involved in building code violation, which will help augment enforcement of building codes apparently.*

The results show that the highest percentage of insulation was in the walls and the roof, where the percentage of houses that the insulation of 92.9%, while the proportion of housing that was isolated in the ceiling only 3.6%, and the percentage of isolated housing in the walls only and the part of the ceiling 1.8% each, Figure (11).

#### Methodology

*A random simple sample was used on a group of blocks in two representative administrative districts (zonings), namely Alkoum and Alshaba, in Amman City Figure (3), to be subjected to the survey (Table 1). The two districts were selected based on observing the spatial trends in housing expansion in the city, which was found to be accelerating faster in three directions of the city. But the southern part of the city was expanding at a faster rate than the northern and eastern directions, compared to a slower expansion to the west side due to fronting with the administrative boundaries of the nearby Albalqa and Madaba Governorates Figure (3). One of reasons behind the northern and eastern or northeastern housing expansion is attributed to a growing re-locating activity of big number of commuters to Amman from the second largest nearby city in Jordan, namely Zarqa City, bounding*



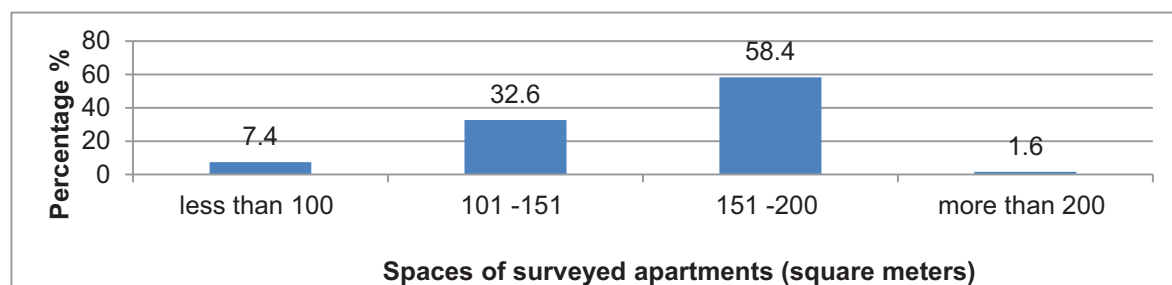


Amman totally from the north and northeast (Fig. 1). Those relocating commuters found the northern, northeastern and eastern parts of Amman close regions to their original places of residency in Zarqa. The southern expansion direction is mainly attributed to the vast open lands available for housing construction projects where administrative borders of the nearest major residential city in the south is faraway to restrict expansion, which now bypassed the international airport in the city, a place used to be a faraway landmark in southern Amman.

Fig. 1. A map of Jordan's governorates and boundaries and location of Amman City

## Results

The questionnaire analyses revealed that 58.4% of the surveyed samples had an apartment area between 151 to 200 m<sup>2</sup> Figure (4), which is the common size of apartments for the middle class in Jordan, the latter equal to 70 per cent or more of the population in Jordan (Fanek, 2018).

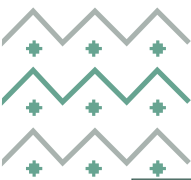


## Conclusions

- This was a first of its kind advocacy-oriented research in the history of the country to advocate a prolonged overlooked basic right, published based on original evidence data generated from a carefully-designed questionnaire and aided by a ground truthing state-of-the-art IR imagery technology;
- The absence of thermal insulation in dwellings in Amman (only 5.8% insulated) could be one of the main reasons of the high-energy consumption rate of the household sector in the national energy balance compared to other sectors;
- At the time of submitting this paper for publication, some fruits of the research-based organized advocacy campaign because of this project started to be cultivated. The campaign encompassed, after conducting the field survey, preparing a position paper, producing a short awareness-raising documentary uploaded on YouTube in Arabic (Abdel-Fattah, 2018), releasing media and press articles, and holding roundtable stakeholder meetings bounded representatives from the six building codes-involved [Format: single space, 10 point font, Times New Roman]

## References

- Abdel-Fattah, A., 2018. Thermal Insulation (%) in Amman's Buildings. Youtube video.
- Akimoto, T., Tanabe, S., Yanai, T., Sasaki, M., 2010. Thermal comfort and productivity - Evaluation of workplace environment in a task conditioned office. *Build. Environ.* 45, 45–50.  
<https://doi.org/https://doi.org/10.1016/j.buildenv.2009.06.022>
- Al-Ghandoor, A., 2013. Evaluation of energy use in Jordan using energy and exergy analyses. *Energy Build.* 59, 1–10.
- Al-Hinti, I., Al-Sallami, H., 2017. Potentials and Barriers of Energy Saving in Jordan's Residential Sector through Thermal Insulation. *Jordan J. Mech. Ind. Eng.* 11.
- Anisimova, N., 2011. The capability to reduce primary energy demand in EU housing. *Energy Build.* 43, 2747–2751.  
<https://doi.org/https://doi.org/10.1016/j.enbuild.2011.06.029>
- Assembly, U.N.G., 1948. Universal declaration of human rights. *UN Gen. Assem.* 302.
- Badran, A.A., Jaradat, A.W., Bahbouh, M.N., 2012. Comparative study of continuous versus intermittent heating for



## ***WHAT ROLE DOES ENERGY EFFICIENCY PLAY IN CLIMATE MITIGATION IN SAUDI ARABIA? TIME SERIES QUANTILE AND OUT-OF-SAMPLE FORECAST APPROACHES***

Fateh Belaïd, King Abdullah Petroleum Studies and Research Center, P.O. Box 88550, Riyadh 11672, KSA, [fateh.belaid@kapsarc.org](mailto:fateh.belaid@kapsarc.org)  
Camille Massié, FGES, Lille Catholic University, France, [camille.massie@univ-catholille.fr](mailto:camille.massie@univ-catholille.fr)

### **Overview**

This article studies a crucial question, which has been at the core of the economic and political debate in the last few decades, that is, the ability of energy efficiency to alleviate environmental degradation in emerging economies. A focus is made on Saudi Arabia, which is the largest country in the Middle East, both in terms of land and economy, and has recently faced significant urbanization and population growth. Since 1990, structural reforms in Saudi Arabia, also known as "Saudization," have been developed to boost the country's privatization, encourage economic diversification, and foster investment regimes. In 2016, the country also established the "Vision 2030 plan", seeking to expand the sustainability of resources for future generations while maximizing the well-being of citizens in the present. Reducing the economy's carbon footprint has then been at the core of country's recent energy policies, in compliance with the country's commitment to Paris Agreement goals and its long-term environmental protection plans. Essentially, Saudi Arabia, in 2021, announced its commitment to achieving net-zero emissions target by 2060. Therefore, this study examines how energy efficiency may contribute to achieving Saudi Arabia's carbon neutrality. First, it implements an empirical approach to investigate the impact of energy efficiency on CO2 emissions. It then simulates the contribution of energy efficiency to Saudi Arabia's net-zero commitments by 2060.

This article makes two significant contributions to the literature on the carbon-energy intensities nexus. First, its empirical contribution relies on using a large sample covering almost four decades, from 1971 to 2020, in a context of a booming economy committed to the energy transition, Saudi Arabia. Second, its methodological contribution consists of developing an innovative quantile regression (QR) approach, along with a simulation process seeking to forecast the joint dynamics of carbon and energy intensities, aligning with the Saudi government's energy efficiency improvement objectives.

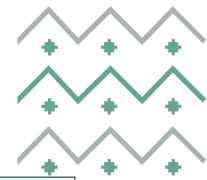
### **Methods**

This study uses annual data from 1971 to 2020 for Saudi Arabia to analyze the relationship between environmental quality and energy efficiency. Data are sourced from World Bank Development Indicator (WDI), the International Energy Agency (IEA), and Enerdata. First, environmental quality is proxied by carbon intensity, which represents our dependent variable. It measures the amount of CO2 produced, or emitted, per dollar of GDP, hence obtained by taking the ratio between global annual CO2 emissions (in Mt) and the country's GDP (in constant price, 2015 US dollars). A lower and decreasing carbon intensity, therefore, constitutes good news for both the environment and the economy. Second, energy efficiency is proxied by Saudi Arabia's level of energy intensity. The same concept applies: it indicates how much energy is used to produce one unit of economic output. Computed by dividing the country's energy consumption (in Koe) by its GDP (in constant price, 2015 US dollars), a lower ratio indicates that less energy is used to produce one unit of output, the economy is then more energy-efficient. Total energy consumption includes coal, gas, oil, electricity, heat, and biomass. Third, electricity intensity is used later in the analysis to explain carbon intensity. It consists in dividing the annual electricity consumption (of residential, tertiary, and agricultural sectors, in kWh) by the country's annual GDP (in constant price, 2015 US dollars). The Augmented Dickey-Fuller and Phillips-Perron unit root tests indicate that variables are stationary in their levels.

To achieve our goal of analyzing the carbon-energy intensities nexus, we apply a QR model, which expands the mean regression model to conditional quantiles of the dependent variable, and is then able to examine the asymmetric features of the dependent variable distribution. Having many advantages over the Ordinary Least Squares (OLS) modeling, QR reveals distributional effects that can significantly differ across quantiles. According to the heterogeneous distribution of carbon intensity, we delineate five quantiles (0.10, 0.25, 0.50, 0.75, and 0.90). Post-estimation quantile equality slope and symmetric quantile tests jointly confirm the suitability of QR to answer our research question.

The robustness of our QR model is first tackled by changing our variable of interest. Indeed, we narrow our scope of analysis and opt for electricity intensity instead of energy intensity in a broader sense. Second, several control variables explaining carbon intensity are added to the model to avoid omitting a relevant variable and, eventually, obtaining biased estimators. Following the literature, they are: total exports and imports as a share of GDP as a proxy





of trade openness, population density (person per square kilometer of land area), and annual cooling degree days (CDD) as a proxy of climate. We also include two dummies accounting for the country's recent energy price reforms which occurred in 2016 and 2018. Since reforms seek to curb national energy consumption, resulting in a decrease in carbon intensity, we expect the coefficient of the dummies to be negative.

We further extend the analysis and proceed to out-of-sample forecasts over the 2021-2060 period. We test the effect on carbon intensity of a 30%-reduction of energy intensity scenario, attained in 2060, with an intermediary 15%-reduction objective in 2030, which corresponds to an energy efficiency improvement in Saudi economic growth. Predicting the impact of such a scenario can help policymakers scale up efforts, design effective mitigation policies, and consider energy efficiency as a vehicle for achieving climate stability and building a better future.

## Results

A first OLS model is developed and estimates the linear and average relationship between carbon and energy intensities, revealing the strong and significant impact of energy intensity on carbon intensity: a 1%-decrease in energy intensity, i.e., a more energy-efficient generation of Saudi GDP, decreases carbon intensity by 0.42%, in general. In agreement with the model's underlying conditions, this regression yields normal and homoskedastic residuals and a satisfactory R-squared of 0.88. Further empirical investigations conducted via QR, show that the effect of energy intensity on carbon intensity is significant and heterogeneous across quantiles: the most potent impact of a 1%-decrease in energy intensity occurs at the 25<sup>th</sup> quantile and reaches a 0.45%-decrease in carbon intensity. Parameters estimates follow a bell-shaped distribution across the five quantiles of carbon intensity.

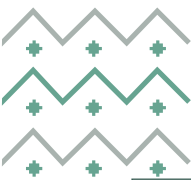
Our model is robust to several changes in the estimation process. First, narrowing our scope of analysis by replacing energy intensity with electricity intensity suggests consistent results. The effect of electricity intensity on carbon intensity is also heterogeneous across quantiles, ranging from a significant 0.21% to 0.26%-decrease in carbon intensity after a 1%-decrease in electricity intensity. However, changes in electricity intensity affect carbon intensity less than changes in energy intensity since the latter encompasses more energy types (coal, gas, oil, heat, and biomass, on top of electricity). It is therefore logical that the consumption of a particular energy, here electricity, is less responsible for CO<sub>2</sub> emissions than all energies combined. Regardless of quantile distribution, a simple OLS model provides a significant estimate of the effect of 0.23%, along with a satisfactory R-squared of 0.87 and normal residuals. Comparing the goodness of fit of the two OLS models indicates that our main model, including energy intensity rather than electricity intensity, is more accurate since the lowest values of AIC and BIC are jointly reached, along with a slightly higher R-squared. Second, adding controls (trade openness, population density, CDD, and two dummies referring to the recent national energy price reforms) to the model explaining carbon intensity confirms the absence of omitted variable bias, since none of the controls are significant, a conclusion reached by both OLS and QR models. Results also suggest that the effects of energy price reforms are yet to come. All in all, energy intensity is the country's best and unique determinant of carbon intensity. Surely it is due to the energy efficiency concept's large scope and the variety of its indicators and determinants. Energy efficiency is undoubtedly influenced by climate, population size, growth, and repartition on the territory, but also by trade, especially when exports consist almost entirely of petroleum and derived products, as is the case in Saudi Arabia. The non-significance of controls is then not surprising as they are already implicitly accounted for by energy efficiency, proxied by energy intensity.

Finally, forecasts of Saudi Arabia's carbon intensity, based on the simulated future energy intensity (30%-reduction by 2060, the intermediary objective of 15%-reduction in 2030), suggest that this effort, if realized, indeed puts the economy on the right track since carbon intensity is curbed by 19%. This result is promising: since the tested scenario only focuses on energy efficiency improvement, hereby proxied by reductions in energy intensity, it indicates that concentrating efforts on energy efficiency only already participates to one-fifth of the government's objective. Other levers can be activated to reach the remaining four-fifths and accelerate the decarbonization of the economy, such as the development of hydrogen, the diversification of energy production and consumption sources, and the openness to greener energies.

## Conclusions

Saudia Arabia must ambitiously curtail GHG emissions to achieve climate sustainability goals. Drawing on an empirical approach, this article highlights the role of energy efficiency in shaping GHG emissions in Saudi Arabia. The results illustrate the prominent role of energy efficiency in determining past and future GHG emissions in the Kingdom. Offering robust estimates, the use of OLS and QR reflects the heterogeneity of the impact of energy efficiency improvement on carbon intensity. The forecast of future carbon intensity after energy efficiency improvements in the Saudi economy confirms that ongoing efforts will put the country on the track to carbon neutrality. This is also suggestive of the need to activate other levers having the ability to accelerate the energy decarbonization process, including carbon capture and storage, and green energy technologies.





## *The Role of Residential Energy Efficiency in Reducing Energy Demand and Reaching Saudi Arabia's 2060 Net Zero Target*

Mohammad Aldubyan, KAPSARC, +966112903164, mohammad.dubyan@kapsarc.org

### Overview

The residential sector has been the highest electricity consumer in Saudi Arabia for decades. In 2020, the sector accounted for 47 percent of total domestic electricity consumption, around 138 TWh. Yet, the potential for enhancing energy efficiency, and hence reducing electricity demand and mitigating carbon footprint within the sector has remained mostly untapped. Thus, improving the sector's energy efficiency can curb the overall domestic energy demand, alleviate depleting natural resources, mitigate greenhouse gas emission, and pave the way for the Kingdom's 2060 Net Zero target. This paper aims at forecasting the residential electricity consumption and assessing the impact of energy efficiency on curbing the demand in existing and future Saudi homes. The forecast is part of the Residential Energy Model (REEM), a KAPSARC model that simulates electricity consumption of the entire residential building stock by different building types, vintages, and geographical locations. Thus, the ultimate goal of this paper is twofold, i) to forecast the residential electricity consumption and predict its growth up to 2060, and ii) to evaluate the effectiveness of different energy efficiency programs in diverting the expected upward growth in order to contribute to Saudi Arabia's net zero target by 2060. The paper is expected to examine different energy efficiency scenarios dedicated to either existing, new buildings, or even both. The paper, and ultimately the model, is expected to provide policy makers with insights regarding how, when, and where to invest in energy efficiency in order to achieve a certain level of electricity consumption, and hence carbon footprint.

### Methods

This research work aims at constructing a forecast of the residential electricity demand and linking it to the Residential Energy Model (REEM), which is an engineering-economic bottom-up model to simulate energy consumption of the entire Saudi residential building stock by building type, vintage, and weather conditions. The electricity forecast is based on the historical electricity consumption as well as some other factors, that have been playing a significant role in shaping the demand, such as GDP, electricity prices, etc. The analysis, afterward, disaggregates the forecasted electricity consumption into two portions, electricity consumption caused by the existing buildings, and an anticipated electricity consumption caused by the future (new) stock. The latter is the difference between the overall forecasted electricity consumption and the baseline of the existing stock. Given the capabilities of REEM to simulate the impact of different energy efficiency programs on residential electricity demand, the simulation helps policy makers to predict changes in the forecasted electricity consumption associated with different energy efficiency programs dedicated to existing stock or new buildings. In other words, the analysis can help policy makers identifying the optimum energy efficiency retrofits for existing buildings as well as designing the standards of new buildings so that they collectively contribute to the national 2060 net zero target.

### Results

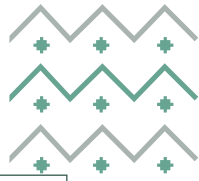
As mentioned above, this paper, and ultimately the model, aim at estimating the residential electricity demand by 2060, when Saudi Arabia is expected to reach net zero carbon footprint. Thus, the main output of this analysis is a forecast of the residential electricity consumption that extends from 2022 to 2060. This forecast will show the evolution of residential electricity demand associated with different potential energy efficiency programs to be implemented within the existing buildings and potential stringent standards to be enforced on new buildings. In addition, the analysis also shows the expected residential electricity demand if Saudi Arabia maintain the current efficiency policies both for existing and new buildings at any given year throughout the forecasted period. For example, if Saudi Arabia has a plan to enforce new insulation standards on new buildings starting from 2030, then the analysis can compare the expected electricity consumption relative to a scenario where no new insulation enforcement was introduced. In other words, the analysis can show the impact of this new policy on the evolution of electricity demand from the date of implementing the policy to 2060.

### Conclusions

In order to reach the carbon emission net zero goal by 2060, Saudi Arabia has to target the main drivers of local energy consumption. The residential sector has been the largest consumer for electricity driven mainly by the hot weather conditions, and hence the heavy demand for cooling, among other factors. This paper shows a long term forecast of residential electricity consumption (up to 2060) and the expected impact of different energy efficiency programs on curbing the future consumption in order to achieve the net zero goals. The analysis shows different scenarios for the most effective energy efficiency programs dedicated either for existing buildings, new standards for new constructions, or both.







## Performance assessment of air conditioning system assisted by photovoltaic cold thermal storage

**Kashif Irshad**, Interdisciplinary Research Centre in Renewable Energy and Power Systems, King Fahd University of Petroleum & Minerals, Dhahran (31261), Saudi Arabia

Researcher at K.A.CARE Energy Research & Innovation Centre at Dhahran, Saudi Arabia  
 +966138601184, [kashif.irshad@kfupm.edu.sa](mailto:kashif.irshad@kfupm.edu.sa)

**Firoz Khan**, Interdisciplinary Research Centre in Renewable Energy and Power Systems, King Fahd University of Petroleum & Minerals, Dhahran (31261), Saudi Arabia, +966138607019, [firoz.khan@kfupm.edu.sa](mailto:firoz.khan@kfupm.edu.sa)

**Md. Hasan Zahir**, Interdisciplinary Research Centre in Renewable Energy and Power Systems, King Fahd University of Petroleum & Minerals, Dhahran (31261), Saudi Arabia, +966542856377, [hzahir@kfupm.edu.sa](mailto:hzahir@kfupm.edu.sa)

**Amjad Ali**, Interdisciplinary Research Centre in Renewable Energy and Power Systems, King Fahd University of Petroleum & Minerals, Dhahran (31261), Saudi Arabia, +966531082131, [amjad.ali@kfupm.edu.sa](mailto:amjad.ali@kfupm.edu.sa)

### Overview

In this paper, a concept for using solar-powered phase change material (PCM) cold thermal storage to boost the cooling performance of an air conditioner in Dhahran, Saudi Arabia, is given. The thermal performance of a novel porous  $\text{Ca}^{2+}$ -doped  $\text{MgCO}_3$  matrix with PEG as the functional phase is evaluated by reducing the air temperature entering the evaporating coil. Instead of using the energy-intensive AC compressor, the system utilizes the cold PCM that was stored during off-peak hours. It reduces cooling expenses and carbon emissions by using just 5% of the power normally required. This system is totally powered by solar photovoltaics, which reduces energy consumption, carbon emissions, and operational expenses for customers.

### Methods

The photovoltaic powered PCM thermal storage system coupled with the air conditioning system consists of a solar PV system, refrigeration system, PCM thermal storage system, and traditional air conditioning system. The working diagram of the system is shown in Figure 1. The system is directly coupled with the existing AC units. PV panels installed over the system, receive solar energy from the sun and convert it into direct current (DC), producing electrical energy during daytime. This DC can be converted into an alternating current (AC) by using an inverter or use directly to run the refrigerator system as shown in Figure 1.

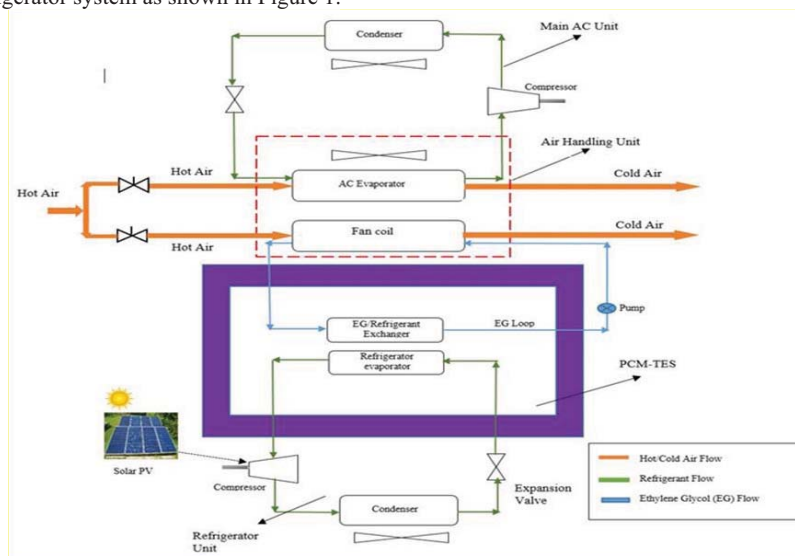


Figure 1: Working principle of photovoltaic powered PCM thermal storage system coupled with the air conditioning system

The battery bank will also be installed to maintain stability in energy supply during the operation. The refrigerator coil will be immersed in the PCM solution stored in the additional TES tank. The novel porous  $\text{Ca}^{2+}$ -doped  $\text{MgCO}_3$  matrix and PEG as the functional phase is used as a PCM.  $\text{PEG}/\text{CaMgCO}_3$  composites PCM used in the system because of its high thermal enthalpies, stability and operational temperature range as compared to traditional shape stabilized PCMs.





The secondary refrigerant from refrigerator circulates through the copper coils absorb heat from the PCM store in the insulated tank and solidifies it. This phase is known as the charging phase. When all the PCM unit becomes solidified, the condensing unit then switches off. The stored solidified PCM remaining in its position until cooling energy is needed. During daytime when the ambient temperature rises, the existing AC unit must do extra work to cool the buildings, and hence power consumption increases. During this time, the solidified PCM comes into play and rather than supplying cooling through the compressor of AC units, solidified PCM start melting to absorb the energy of hot refrigerant and supply cool refrigerant in the additional cooling coil. The coil and refrigeration system is designed for maximum exchange of energy at all sorts of ambient and indoor temperature. As the system is physically isolated from existing compressor units, its operation can be controlled independently.

## Results

The performance of photovoltaic powered PCM thermal storage system coupled with the air conditioning system were carried under six different conditions as present in Figure 1. Type A to Type C conditions represent outlet air temperature under variable input air temperatures which were 33 °C, 34 °C and 35 °C. Type D to Type F conditions represent outlet air temperature under variable input air flow rate which were 900 CFM, 750 CFM and 500 CFM.

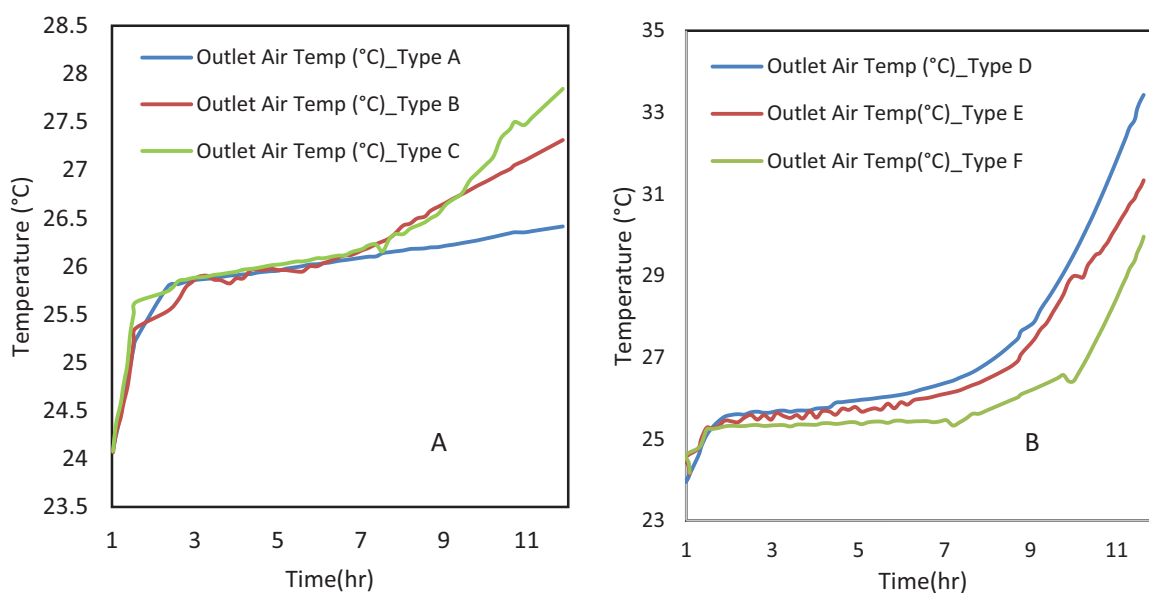
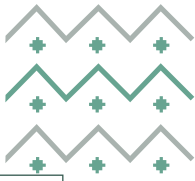


Figure 1. A: Variation of outlet air temperature under variable input air temperature condition; B: Variation of outlet air temperature under variable air flow rate conditions

The influence of air flow rate and entrance air temperature on exit air temperature over the course of a day was noted in Figures 1 A and B. A greater heat load is the result of an increase in input air temperature or air flow rate. The propagation of heat accelerates the melting of PCMs. Therefore, the rate of heat transfer will decrease. Consequently, the output air temperature increases as the input air temperature rises. In addition, the output air temperature curve in Figure 1 B rises as air velocity increases, resulting in a maximum increase in discharge air temperature. More results will be presented in full conference paper.

## Conclusions

Using an experimental approach based on the effective heat capacity technique, the effectiveness of a photovoltaic-powered PCM thermal storage system paired with an air conditioning system is investigated. Calculations of the effects of the input air temperature and air flow rate on the system's performance are based on the system's melting period throughout the day. Higher intake air temperature and air flow rate raise the output air temperature and the amount of heat absorbed by the PCMs, respectively, while also accelerating the rate of heat transfer and decreasing charging time.



## Energy efficiency for sustainable development in Nigeria.

<sup>1</sup>Humphrey Otombosoba Oruwari ( PhD)

NNPC Upstream Investment Management Services (NUIMS) a subsidiary of Nigerian National Petroleum Company (NNPC)

Borno project House opposite Federal High court Maitama Abuja

[horuwari@gmail.com](mailto:horuwari@gmail.com) 08035521748

<sup>2</sup>Lucky Itsekor (DBA), Valourteyn Nigeria Limited

### Abstract

#### Objectives/Scope:

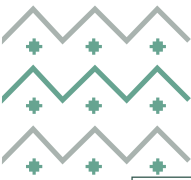
The objectives of the study are as follows: Examine how energy efficiency can promote industrialization and job creation. Assess how energy diversification helps in reviving the Nigeria economy. Discuss the impact of economic growth with reference to energy efficiency. Indicate the ways Nigeria can improve its energy capacity with renewable resources and finally make recommendations for policy decisions.

**Methods, Procedures, Process:** The methodological framework for the study comprised extensive literature review and policy analysis. The literature review will focus on energy policies and institutional issues in relation to energy efficiency across various the different region of the world. The Nigerian government policy on energy efficiency will be reviewed to discuss certain hitherto neglected strategies and mechanism with an overall orientation that gives general direction and chart the way forward for sustainable management of energy resources. Relevant literature report from form journal, text books, energy policies and relevant government agencies like the Nigeria National Petroleum Company (NNPC), Energy Commission of Nigeria (ECN), and documents from different multinational operating in Nigeria. Also, articles dealing on energy efficiency and sustainable development were consulted. The policy options that support energy efficiency were analyzed.

**Results, Observations, Conclusions:** The study finding revealed that energy efficiency resulted in cost saving and revenue generation while the use of renewable sources like hydro and solar energy reduced environmental pollution. Energy efficiency also enhanced energy security and will mitigate climate changes due to reduced emission of green house gases into the atmosphere. In conclusion, energy efficiency can contribute to all the three pillars of sustainable development namely economic, social and technological dimension in the Nigerian economy. The study recommended that in order to reduce the challenges associated with energy access and use there should be creation of an enabling environment like provision of fund for energy generation and development to attract investment in energy sector. the government of Nigeria should institute a regulatory framework that protect the interest of investors in energy market. There should be correct pricing of energy resources to enable cost recovery by investors. Also, research and development in energy field should be encouraged.

**Novel/Additive Information:** The paper provides a strategic management model for efficient management of energy resources in Nigeria. The proposed model can be used as an input into wider risk assessment frame work for investment decision.





## Submission Summary

**Conference Name**

44th IAEE International Conference - 2023

**Paper ID**

245

**Paper Title**

Improving Energy Performance in Residential Buildings in Saudi Arabia

**Abstract**

Saudi Arabia, like many developing countries, is experiencing rapid urbanisation and infrastructure expansion, especially in the area of residential buildings. With current demand threatening long-term energy security and forecasts indicating that domestic energy consumption will rise at a rate of 5% to 7% annually, it is crucial to improve the energy and environmental performance of the building stock. This paper explores the most effective ways to achieve energy efficiency in residential buildings in the context of Saudi Arabia. An existing family villa, representing a typical dwelling type in Saudi Arabia, was selected for modelling purposes, and examined to identify design weaknesses and propose effective remedies, using DesignBuilder software. The results of the simulations show that energy consumption and peak electricity demand could be reduced significantly by implementing the optimal strategies proposed in the framework. A potential reduction of 68% in total electricity consumption and 74% in peak electricity demand was shown to be possible, with nearly 81% reduction in cooling energy use intensity (EUI) bringing Saudi Arabia within the range of recommended European standards.

**Created on**

9/9/2022, 4:14:47 PM

**Last Modified**

9/9/2022, 4:14:47 PM

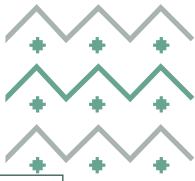
**Authors**

**MANA ALYAMI** ( NAJRAN UNIVERSITY ) < mmsalmansour@nu.edu.sa > ✓

**Primary Subject Area**

Energy Efficiency





## MICRO-SPATIAL MODEL OF RIYADH DOMESTIC ELECTRICITY USE

John E. Abraham, HBA Specto Inc.

Abdel Muhsen, KAPSARC

Geraldine Fuenmayor, HBA Specto Inc.

Amila Sandaradura, KAPSARC

Kevin J. Stefan, HBA Specto Inc.

### Overview

A time-series spatial-economic simulation model of the future development of Riyadh, Saudi Arabia was constructed, following the Production Exchange Consumption Allocation System (PECAS) framework. A short-term annual equilibrium spatial interaction model based on a unification of random utility theory with input-output theory works together with a real estate supply/demand model for the cadaster. The PECAS framework is commonly used to predict transportation energy use; we extended the framework to include the use of electricity by households, which is used primarily for cooling. A disaggregate residential electricity demand model was estimated based on self-reported electricity consumption, which considers demographic characteristics (household size, ethnicity, etc.) and dwelling characteristics (dwelling size, structure type, etc.). A full list of synthetic households is associated with individual buildings for each year of the simulation. For each such household, the economic spatial relationships are used to predict transportation energy use, and the dwelling and household characteristics are used to predict residential electricity use. This model will be used to predict the future use of energy by households in different scenarios, including District Cooling scenarios, to develop policies for land use, transportation, and energy that work together towards a future for Riyadh that is both economically strong and energy efficient.

### Methods

A household survey from the Royal Commission of Riyadh City (RCRC) provided information on household and housing characteristics (especially dwelling type and size) which was used in a household synthesis process [1] to develop a complete representation of households in dwellings in Riyadh. This was informed by a cadaster inventory of the development in 2016 in Riyadh, also from RCRC, and labor-market occupation level statistics for Riyadh province.

A simulation model was built using the PECAS[2] framework. One of the two modules in PECAS is a short-term annual equilibrium economic interaction model called Activity Allocation (AA) based on Input-Output theory, made spatial through random-utility theory. The AA module for Riyadh was developed by adapting the national social accounting matrix to the city based on population and labor market summaries, and then further disaggregating to neighborhoods (called Hai) and transportation analysis zones, based on housing characteristics. This was used to develop a simulation of the economic flows between locations, including various economic flow relationships that are connected to household travel, such as commuting trips (labor flows), shopping trips (retail goods flows), and trips to schools (education service flows.). These spatial flows consider the transportation zone-to-zone characteristics from a travel model of Riyadh, also from the RCRC – destination choices consider supply/demand balance (resulting in spatial price maps), heterogeneity in opportunities, and travel conditions.

The RCRC household survey reported for a subset of users the monthly energy expenditure in SAR; these records were used to develop a linear regression model predicting energy expenditure by household, considering the household's demographics, dwelling type and size, tenure and vehicle ownership. Household energy consumption was added as an additional input/output in the PECAS AA module, with demand dependent on dwelling type, dwelling size, and nationality, and supply generated by the electricity utility.

The result is a synthetic one-to-one representation of households in Riyadh, assigned to cadastral parcels based on spatial economic choices including labor market supply and housing demand. For each of these synthetic households, their household electricity use is predicted based on their housing and household characteristics. This synthetic micro-representation of energy use provides insight into energy use at a detailed level, spatially (at a fine geography), and connected to other variables in the simulation such as occupation, nationality, and dwelling size.





## Results

The table below shows the coefficients in the linear regression model of 2016 energy use.

OLS Regression Results

---

Dep. Variable:	ElecExpense	R-squared:	0.331
Model:	OLS	Adj. R-squared:	0.328
Method:	Least Squares	F-statistic:	97.41
Date:	Wed, 01 Dec 2021	Prob (F-statistic):	3.94e-212
Time:	13:18:24	Log-Likelihood:	-17501.
No. Observations:	2573	AIC:	3.503e+04
Df Residuals:	2559	BIC:	3.511e+04
Df Model:	13		
Covariance Type:	nonrobust		

---

	coef	std err	t	P> t	[0.025	0.975]
const	86.7881	17.066	5.085	0.000	53.323	120.254
BldgArea	0.0510	0.030	1.694	0.090	-0.008	0.110
RoomsCap	6.3509	4.099	1.549	0.121	-1.687	14.389
Rooms_VillaPal	15.3248	3.014	5.084	0.000	9.414	21.235
Rooms_Indig	-4.2918	3.130	-1.371	0.170	-10.430	1.846
Is_Rent	-26.7910	12.038	-2.226	0.026	-50.396	-3.185
People_EmpOth	-12.0263	3.182	-3.779	0.000	-18.267	-5.786
People	15.6854	1.883	8.332	0.000	11.994	19.377
Vehicles	12.1280	3.821	3.174	0.002	4.635	19.621
Work_S	16.4926	5.219	3.160	0.002	6.260	26.726
Work_N_50	18.9166	8.646	2.188	0.029	1.963	35.870
Work_S_50	16.1031	9.415	1.710	0.087	-2.359	34.565
Saudi_NWA	14.2528	3.166	4.502	0.000	8.045	20.461
NS_Kids	-9.6702	3.618	-2.673	0.008	-16.764	-2.577

---

Omnibus:	1128.677	Durbin-Watson:	1.748
Prob(Omnibus):	0.000	Jarque-Bera (JB):	7483.317
Skew:	1.958	Prob(JB):	0.00
Kurtosis:	10.380	Cond. No.	1.45e+03

---

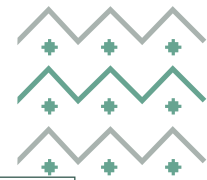
where:

- const – constant allocated to all units (intercept)
- BldgArea – building area, sq m
- RoomsCap – Number of rooms, capped at 10, for all structural types
- Rooms\_VillaPal – Number of rooms (capped at 10), additional amount only if the unit is Villa or Palace structural type
- Rooms\_Indig – Number of rooms (capped at 10), additional amount only if the unit is Indigenous housing
- Is\_Rent – Household tenure is rent
- People\_EmpOth – Number of people; if household tenure is Employer-paid or Other (not rent or own)
- Vehicles – Number of vehicles owned by the household
- People – Number of people in the household
- Work\_S – Number of workers in the household who are Saudi citizens
- Work\_N\_50 – Number of workers in the household who are Non Saudi citizens, occupation group 50, 51, 52 (skilled)
- Work\_S\_50 – Number of workers in the household who are Saudi citizens, occupation group 50, 51, 52 (skilled)
- Saudi\_NWA – Number of Saudi nonworking adults (18 years old and over)
- NS\_Kids – Number of non-Saudi children

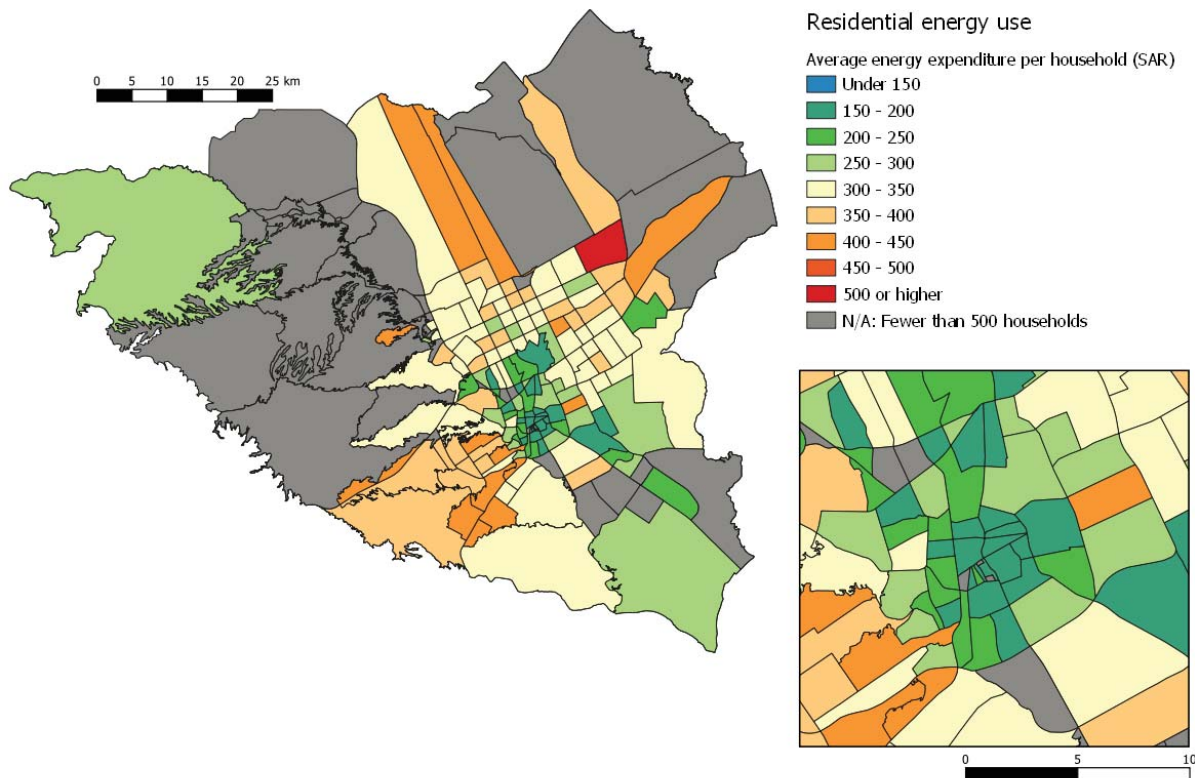
The per-person marginal contribution from each person type is summarized below:

	Saudi	NonSaudi
Child under 18	15.69	6.02
Nonworking adult	29.94	15.69
Worker, occupation 53+ (blue collar)	32.18	15.69
Worker, occupation 50-52 (white collar)	46.43	34.60





When this model is applied to the synthetic population, it provides an estimate of household electricity use for each household, which have each been assigned to a cadastral parcel, which can be summarized in a number of ways. For example, the zonal average of electricity energy use per household in the simulation in the calibration year is shown in the map below.



### Conclusions

The use of energy in Riyadh is of great interest in national policy. This research connects household electricity use to housing characteristics and household characteristics, including nationality, occupations, dwelling structure type, and dwelling size. This is also connected to a spatial economic simulation model designed to predict the future spatial patterns and spatial interactions in Riyadh over the next decades, accounting for the demand for housing integrated into the demand and supply for all other goods and services, including labour markets and the provision of goods and services to households by businesses.

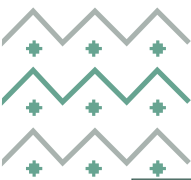
The reference year (2016) electricity consumption patterns reported here show that certain types of housing and certain types of households consume greater and lesser amounts of electricity, providing insight into the types of patterns that could lead to lower per-capita energy consumption in the future, as Riyadh continues to grow and develop.

The next step in this project is to simulate development scenarios for the future where District Cooling is applied in certain locations, with different policy regulations, incentives, and disincentives, to forecast the resulting reduced energy use in dwellings. The spatial simulation will forecast the secondary impact of District Cooling policies on spatial patterns of travel and development, as well as potential impacts on overall economic performance, and the changes in the use of energy in transportation due to the changes in spatial patterns. This future research should help fine-tune District Cooling policies and identify the most opportune locations for District Cooling projects.

### References

- [1] J. E. Abraham, K. J. Stefan, and J. D. Hunt, "Population Synthesis Using Combinatorial Optimization at Multiple Levels," presented at the Transportation Research Board 91st Annual Meeting, 2012. Accessed: May 13, 2014. [Online]. Available: <http://trid.trb.org/view.aspx?id=1130260>
- [2] J. D. Hunt and J. E. Abraham, "Design and implementation of PECAS: A generalized system for the allocation of economic production, exchange and consumption quantities," in *Integrated Land-Use and Transportation Models: Behavioural Foundations*, M. Lee Gosselin and S. Doherty, Eds. Amsterdam: Elsevier, 2005, pp. 253–274.





## ***DYNAMIC ELECTRICITY TARIFFS AND WILLINGNESS TO ENGAGE ON THE RESIDENTIAL SIDE: QUANTIFYING THE POTENTIAL OF ENERGY INTENSIVE CONSUMERS IN A REAL CASE SCENARIO***

[Faisal Alsallum, Center of Excellence for Complex Engineering Systems, FAlsallum@kacst.edu.sa]

[Carlos Batlle, MIT Energy Initiative, CBattle@mit.edu]

[Tim Schittekatte, MIT Energy Initiative, Schit@mit.edu]

[Abdulelah H. Habib, Center of Excellence for Complex Engineering Systems, Ahabib@kacst.edu.sa]

### **Overview**

The electricity systems transformation processes that started more than two decades ago is still far to be completed. The key foundation of the restructuring was to design adequate regulatory tools to sustain a marginal price-based market environment in which generators and end-users could trade.

While the level of development of market mechanisms on the generation side has been significant, there is still a not short path to go on the end-users' side. Organized wholesale short-term electricity markets have been implemented worldwide. These markets are capable of not only leading to optimal economic dispatches but also of producing efficient and granular price signals revealing the actual marginal cost of supply in each moment (in each hour or even in each five-minute period). Although these mechanisms are being contested recently in the context of the huge energy crisis mainly suffered in the European Union, there is no doubt that they have played a key role to significantly increase the efficiency of the operation and planning of the generation fleet. Two mention a couple of examples, short-term price signals have enhanced the reliability of generation plants in the periods of larger supply needs and increased the flexibility of generation plants (e.g. motivating the renegotiation of operation and maintenance contracts to allow for a more exigent cycling of the plants capable of better respond to price volatility).

However, on the demand side, the actual involvement of end users in this marginal price-based environment is still far from being a reality. In the vast majority of cases, electricity end users, and particularly residential consumers, live with their backs turned to short-term price signals. Some of the reasons behind this lack of involvement are well known: in many cases, electronic meters have not yet been rolled out; but even in those cases in which it has been done, tariff design manages to mute short-term price signals.

The number of electricity systems in which residential users are majoritarily exposed to dynamic energy prices (and time-of-use network charges) is really small. So beyond a large number of pilot projects widespread in different contexts, it is still far from being easy to extract from real practice relevant conclusions on the actual potential of demand response.

While there is a certain consensus (trust) on the economic potential of demand response coming from large consumers, the actual value that could be extracted from residential demand response is still largely unknown. On the one hand, significant barriers are still holding back the deployment, from the aforementioned lack of sufficiently developed tariff designs to data privacy and cybersecurity issues, to name some. But even assuming that these barriers could be removed, there is a major open question: which is actually the willingness to engage of these residential customers. When fully exposed to granular short-term prices, will it be worth for these class of users to modify their consumption patterns?

In this paper we study in detail a real-life case example that allows extracting noteworthy insights to address this last question. First, we develop our analysis in the context of the Spanish electricity market. The Spanish regulatory authority, back in 2014 pioneered the design of end-user tariffs that fully exposed millions of residential customers to dynamic energy prices and time-of-use tariffs. This allows us to use this real hourly price series to quantify the actual economic savings that a fully responsive residential end user could get.

In order to extract sound conclusions from the analysis, not only on the static economic potential of responding, but also on the actual value of it when confronted with the opportunity cost of modifying the usual consumption patterns of end users, we built our analysis around a real consumer who in principle should be among the best suited to engage: a taxi driver owning a fully electric vehicle in the city of Madrid. The rationale behind the study was simple: if it is not worth responding for such a consumer (more than 50 kWh per day), then we should not expect much from regular residential customers.

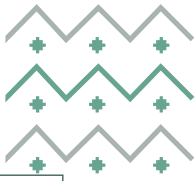
The analysis benefited also from the fact that electricity prices in Spain during the second half of 2021 and the first of 2022 have been abnormally high, due to the well known energy crisis that has multiplied spot prices by at least five (compared with levels of the business as usual prices seen since 2014). We could thus explore extreme cases using real life data, evaluate in each price scenario the level of savings that could be extracting and what could be reasonably expected for a consumer of this nature. For a more realistic response to this last question, we confronted our reference consumer with the alternatives, and received from her a good insight on her willingness to engage in each of the scenarios.

The analysis allows extracting relevant insights to contribute to the open question on the actual role that demand response can play in the future in other jurisdictions, particularly in a future context in which electromobility is further developed.

### **Methods**

We developed an optimization tool that allows minimizing the cost of charging the EV battery subject to the schedule constraints expressed by the owner of the taxi. We calculated the savings that could be obtained from optimizing the





charging every day taken the hourly prices as known, and we focused the analysis on quantifying the economic benefits under two extreme assumptions. In both cases we took as basic condition an 8-hour working journey per day, and then we explore two options: i) fixing the working schedule preferred by the taxi driver and evaluating the savings under these constraints, and ii) prioritizing the minimization of charging costs, even if this would imply an uncomfortable working mode for the taxi driver. As previously discussed, the quantification considered the hourly prices charged to residential customers during the last eight years. This allowed extracting valuable conclusion on the different response of the customer before and during the EU energy crisis.

This analysis allows us to get a clear picture of the real potential of residential demand response for one of the most favourable case that can be conceived, an extremely intensive consumer. The analysis also allowed evaluating willingness to engage of the consumer, when confronting the battery charging savings with her willingness to condition her daily habits.

## Results

The main results, largely discussed in the paper, is that contrary to what it might be expected, not even in the extremely high prices scenario the resulting savings were significant enough to be considered by the taxi driver worth conditioning her working (and life) habits.

Some interesting effects can be advanced:

i) as the renewable penetration increased in Spain, the hourly price pattern changed in two main ways: the increased in solar PV generation gradually depressed prices around noon, turning those hours into the best ones to charge the battery, but the worse ones for the taxi business not to be working, and at the same time, the increased volatility of prices made more difficult to coordinate a stable working schedule with the charging cost minimization.

ii) also, during the energy crisis scenario, contrary to what might be initially expected, the incentive to adapt more the charging of the battery to save costs was as large. The reason behind this conclusion is the fact that while prices during this period were extremely high, the peak/off peak spread was not very significant (gas-fired plants were setting marginal prices in most of the hours due to the dry hydro season and extremely hot summer).

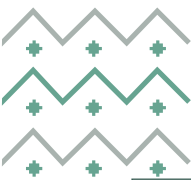
## Conclusions

Demand response should gradually turn into a helpful tool to minimize the cost of electricity supply. In particular, the potential of this alternative on the side of residential consumers should be linked to the ability to properly manage the charging of EV batteries. We explored a real case example considering the hourly prices recorded in one of the few contexts in which a fully sophisticated tariff has been applied to residential costumers, and we evaluated the actual value for being flexible interacting with a real residential customer that in principle should have the largest saving potential conceivable. This allowed us also to consider the willing to engage of the customer depending on the different price scenario and the savings that could be obtained in each of them.

The analysis indicates that the actual potential of demand response among this customer class might not be as large as expected. And in any case, it confirms the need for automation to minimize the need for the user to condition daily habits.

## References

- ACER, 2019. *ACER Market Monitoring Report 2018 –Consumer Empowerment Volume*.
- Annala, S., 2015. *Households' willingness to engage in demand response in the finnish retail electricity market: an empirical study. PhD Thesis*.
- Cornelis, M., 2019. *Citizens at the heart of the European energy transition: how can we put smart meters at the service of users?. Press release*.
- EURELECTRIC, 2019. *15 Pledges To Customers Together For A Sustainable, Inclusive And Smart Energy Future*.
- Hahnel, U., Herberz, M., Pena-Bello, A., Parra, D., Brosch, T., 2020. *Becoming prosumer: Revealing trading preferences and decision-making strategies in peer-to-peer energy communities. Energy Policy*.
- Kowalska-Pyzalska, A., Byrka, K., 2019. *Determinants of the Willingness to Energy Monitoring by Residential Consumers: A Case Study in the City of Wroclaw in Poland. Energies*.
- Kubli, M., Looock, M., Wüstenhagen, R., 2018. *The flexible prosumer: Measuring the willingness to co-create distributed flexibility. Energy Policy*.
- Mrówczyńska, M., Skiba, M., Bazan-Krzywoszańska, A., Sztubecka, M., 2020. *Household standards and socio-economic aspects as a factor determining energy consumption in the city. Applied Energy, vol. 264, art. 114680*.
- National Research Council, 2016. *Overcoming Barriers to Deployment of Plug-in Electric Vehicles. Chapter 3*.
- Nicolson, M., Huebner, G., Shipworth, D., 2017. *Are consumers willing to switch to smart time of use electricity tariffs? The importance of loss-aversion and electric vehicle ownership. Energy Research & Social Science*.
- Stenner, K., Frederiks, E. R., Hobman, E. V., Cook, S., 2017. *Willingness to participate in direct load control: The role of consumer distrust. Applied Energy*.



## ***DETERMINANTS OF ENERGY EFFICIENCY AND RENEWABLE ENERGY INVESTMENTS IN SLOVENIAN SMES?***

Nevenka Hrovatin, University of Ljubljana, School of Economics and Business, +386 1 5892 557, [nevenka.hrovatin@ef.uni-lj.si](mailto:nevenka.hrovatin@ef.uni-lj.si)  
Janez Dolšak, University of Ljubljana, School of Economics and Business, +386 1 5892 550, [janez.dolsak@ef.uni-lj.si](mailto:janez.dolsak@ef.uni-lj.si)  
Jelena Zoric, University of Ljubljana, School of Economics and Business, +386 1 5892 785, [jelena.zoric@ef.uni-lj.si](mailto:jelena.zoric@ef.uni-lj.si)

### **Overview**

Energy efficiency and climate neutrality are of paramount importance to EU Member States' energy policy objectives and overall development goals, particularly because of their potential to improve societal competitiveness, green growth, and employment potential. Consequently, this has been embedded in key EU energy strategies. For example, as part of the European Green Deal, the EU recently adopted a package of legislative proposals entitled "Fit for 55," which aims to achieve climate neutrality by 2050 while reducing net emissions by at least 55% by 2030 compared to 1990 levels (European Commission, 2021). One of the priority areas of policy action to make transformative changes is small and medium-sized enterprises (SMEs), which are considered particularly vulnerable and have fewer resources and information to ensure a successful green transition.

Energy efficiency investments are seen as a cost-effective way to achieve these goals, but the energy efficiency gap persists (Jaffe and Stavins, 1994; Allcott and Greenstone, 2012; Gerarden et al., 2017). A number of empirical studies have been published based on theoretical taxonomies of this phenomenon and their adaptations (Sorrell et al., 2011, Cagno et al., 2013, Cagno and Trianni, 2013), trying to identify the causes of this gap, also called barriers to energy efficiency investments (e.g., Cagno et al., 2013). On the other hand, studies have also tried to identify factors that accelerate these investments (e.g., Cagno and Trianni, 2013), the results of which have been summarized by Solnørdal and Foss (2018). According to Hrovatin et al. (2021), for SMEs, economic barriers and drivers are the most important determinants of their energy efficiency investment decisions, followed by behavioral and organizational barriers and drivers.

In contrast to the theoretical literature in the field of energy efficiency or energy efficiency gaps at the firm level, there are few taxonomies or categorizations of barriers and drivers to investment in RES. An exception in the conceptualization of drivers for investment in RES is the contribution of Wüstenhagen and Menichetti (2012), which recognize energy policy as a key driver for investment in RES in corporate investment, through its influence on two factors, risk and profitability of the investment. On the empirical studies side, there are almost no studies that would focus on discovering the factors of investment in RES at the firm level. The only study that addresses this issue is the one by Segarra-Blasco and Jové-Llopis (2019), which concludes that companies are more inclined to invest in EE than in RES, but that there are significant complementarities between the two types of investments, with energy efficiency strategies being more related to cost efficiency and regulation, and RES strategies being more related to public support programs and environmental awareness.

The objective of this study is to analyze what factors, both barriers and drivers, influence SMEs' decisions to invest in energy efficiency measures and renewable energy investments while determining whether different factors influence both types of investments in the same way or whether firms' motivations for investment behavior differ in the two cases.

### **Methods**

The data set consists of two data sources. The first is a self-administered survey with extensive questionnaires conducted via telephone interviews in 2019 and 2020, and the second is the Slovenian Business Register, an official statistical database of all companies in Slovenia. The final sample is a cross-sectional sample of 270 small and medium-sized enterprises in Slovenia. A bivariate logit model is used to investigate barriers and drivers to investment in EE and RES. In this way, it is possible to analyze two correlated binary outcomes in the joint model as functions of the same explanatory variables. Both dependent variables are therefore dichotomous, with a value of 1 indicating a company's investment in EE and RES, respectively, while a value of 0 indicates the absence of such investment in a given year.

Based on theoretical foundations, empirical evidence from other studies, and data availability, we examine the following factors that affect investment decisions: first, firm- and business-related characteristics such as size, ownership (domestic vs. foreign), profitability (ROA), debt, foreign market participation, innovativeness (company R&D activities), perceived market competition, ownership of company premises, and perception of investment risk; second, energy- and EE -related characteristics such as energy costs (share of energy costs in total expenditures), EE





awareness in the company, managers with real ambitions and long-term strategies, energy person, employee awareness of EE, energy audits, and potential for energy savings.

## Results

The preliminary results of the bivariate logit model show that the joint decision to invest in EE and RES is influenced by the following factors. Ownership of the firm's site, a hired energy consultant, or an audit increase the likelihood of both investments. The share of investments in R&D in all investments and the relative importance of EE in the company increase the probability of investments in EE, while the presence of energy officers in the company and energy expertise increase the probability of investments in RES.

In addition, we test whether there is a difference in perceptions of barriers and drivers to investment in EE and RES between groups of firms that are small vs. medium-sized, manufacturing vs. non-manufacturing, and energy-intensive vs. non-energy-intensive. The results show that barriers and drivers to EE are more prevalent in medium-sized companies than in small companies, as are drivers such as the potential for cost reductions and educational programs in the company. Manufacturing firms consider investments in EE less profitable compared to non-manufacturing firms, while non-manufacturing firms consider awareness-related barriers more important. Interestingly, there are no statistically significant differences between energy-intensive and non-energy-intensive firms in terms of barriers and drivers to investing in EE.

On the other hand, small firms perceive some barriers to investment in RES more strongly than medium-sized firms, such as low return on investment and hidden costs. Non-manufacturing companies perceive barriers such as lack of financial resources and lack of standards and certificates more than manufacturing companies, while the latter perceive the lack of necessary knowledge and awareness in the company more. Non-energy-intensive companies perceive barriers to investment in RES such as too low subsidies, uncertainty about take-back prices, and return on investment more than energy-intensive companies.

## Conclusions

Our study adds to the existing body of knowledge in several ways. Similar to the literature review on theoretical taxonomies of drivers and barriers to investment in EE and empirical findings, we also provide a literature review on theoretical findings on why firms make RES investments. In addition, we review the results of empirical studies on the drivers and barriers to RES investment. The results of our study provide a solid basis for comparing the drivers of the two types of investments. For example, we can find that companies that own their buildings and receive energy advice are more likely to make investments in both EE and RES. Thus, the results of this study provide answers to the question of which factors should be promoted and which should be restricted in common energy policies to improve EE and increase the use of RES. In this way, the goals in both areas could be achieved more quickly without undesirable interactions.

## References

- Allcott, H., & Greenstone, M. (2012). Is there an energy efficiency gap? *Journal of Economic Perspectives*, 26 (1), 3-28.
- Cagno, E., & Trianni, A. (2013). Exploring drivers for energy efficiency within small-and medium-sized enterprises: first evidences from Italian manufacturing enterprises. *Applied Energy*, 104, 276-285.
- Cagno, E., Worrell, E., Trianni, A., Pugliese, G. (2013). A novel approach for barriers to industrial energy efficiency. *Renewable and Sustainable Energy Reviews*, 19, 290-308,
- European Commission (2021). SMEs, social economy enterprises, crafts and liberal professions Fit for 55 – Turning the Challenges into Opportunities. Retrieved 17.8.2022 from <https://www.eesc.europa.eu/en/our-work/opinions-information-reports/opinions/smes-social-economy-enterprises-crafts-and-liberal-professions-fit-55>.
- García-Quevedo, J., & Massa-Camps, X. (2019). Why firms invest (or not) in energy efficiency? A review of the econometric evidence. IEB Working Paper 2019/07.
- Gerarden, T., Newell, R., Stavins, R. (2017). Assessing the energy-efficiency gap. *Journal of Economic Literature*. 55 (4), 1486-1525
- Hrovatin, N., Cagno, E, Dolšak, J., Zorić, J. (2021). How important are perceived barriers and drivers versus other contextual factors for the adoption of energy efficiency measures: An empirical investigation in manufacturing SMEs *Journal of Cleaner Production*, 323, 129123.
- Jaffe A.B., Stavins N. (1994). The energy-efficiency gap—what does it mean? *Energy Policy* 22 (10), 804–810.
- Sorrell S., Mallett A., Nye S. (2011) Barriers to industrial energy efficiency: a literature review. Working paper 10/2011. Vienna: UNIDO (SPRU, University of Sussex).
- Wüstenhagen, R., & Menichetti, E. (2012). Strategic choices for renewable energy investment: Conceptual framework and opportunities for further research. *Energy Policy*. 40, 1-10.





## Submission Summary

### Conference Name

44th IAEE International Conference - 2023

### Paper ID

351

### Paper Title

Sustainable Energy Efficiency improvements through methodology of prioritizing selections

### Abstract

Industrial facilities are rapidly changing over the years, various technological advances have led to break-through its performance. The transformation is brought from new inventions, development of sophisticated processes/technologies, automation, digitalization, the list is continuously increasing. These technical development and strategies to realize it on the life-cycle basis forces the industries to explore sustainability concepts within the scope. On the other hand, the task to reduce Green House Gas emissions to protect environment is needed than ever before. Consequently, the revolution and evolution of products, processes, technologies, and resources, and sustainable requirement to mitigate climatic anomaly beams on the industrial sector and ordained it to cater an approach to optimize all efforts. The challenge is to develop a methodology by accommodating all the technological advances and sustainability requirements and transform facilities into a better performing asset with reduced emission. The solution is to make industrial facilities energy efficient which enable them to be competitive and environmentally friendly.

Saudi Aramco has never ending quest for innovation in technological future products and services. It is evident from its pledge to Operational Excellence and commitment to carbon circular economy. Saudi Aramco is resolute to develop and retrofit all of its facilities to be best-in-class from energy efficiency perspective which is palpable form its Energy Policy. To take on the challenge, Saudi Aramco developed new methodologies to design/retrofits industrial facilities to realize energy efficiency. The interplay of Energy Trilemma requirements i.e. techniques for energy savings, climate change abatement, and overall sustainable development is considered within the framework. Recent enthusiasm for using renewable energy resources, both to reduce expenses associated with traditional sources and to improve environmental conditions is overwhelming. But the emphasis to ensure optimal utilization of materials to achieve energy efficiency improvement through sustainable means is reflected in the developed approach.

In this paper, the developed technique is described which needs to be followed in retrofitting industrial facilities to make them the best-in-class. The methodology is conferred in the form of "Energy Pyramid" which is built on the principle of prioritization i.e. build the base first and then progressive layers are added until we finally get to the peak. It is likely that by following the approach, manufacturing industry of the future will become energy efficient and fully embrace the best practices to optimize resources utilization while consuming less energy. Industrial facility case studies are utilized to enrich and illustrate the subject and demonstrate the methodology appropriately to put them on track to achieve international climate and energy goals.

### Created on

9/12/2022, 8:02:52 AM

### Last Modified

9/12/2022, 8:02:52 AM

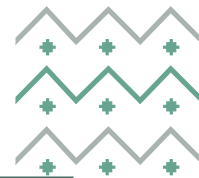
### Authors

Abdulrahman Hazazi ( Aramco ) < [abdulrahman.hazazi@aramco.com](mailto:abdulrahman.hazazi@aramco.com) > ✓

Zeeshan Farooq ( Aramco ) < [ZEESHAN.FAROOQ@ARAMCO.COM](mailto:ZEESHAN.FAROOQ@ARAMCO.COM) > Ⓞ

### Primary Subject Area

Energy Efficiency



## REGULATIONS AND CONTRACT DESIGN IN MULTI-AGENT DISTRICT HEATING AND COOLING SYSTEMS

Maximilian Hoffmann, RWTH Aachen University, +49 176 52867077, maximilian.hoffmann@rwth-aachen.de  
 Frieder Borggreffe, Chair for Energy System Economics, RWTH Aachen University, frieder.borggreffe@eonerc.rwth-aachen.de  
 Aaron Praktijnjo, Chair for Energy System Economics, RWTH Aachen University, apraktijnjo@eonerc.rwth-aachen.de

### Overview

Bidirectional low-temperature district heating and cooling of the 5th generation (5GDHC) belongs to the latest trends within the heat transition. In these networks, distributed heat pumps and compression chillers are used to obtain the demanded temperature levels locally, whereas the network's temperature remains at a level of 5–40°C [Wirtz et al. (2020)]. Therefore, 5GDHC net-works are characterized by a high efficiency and low heat losses as well as by high shares of renewable energy sources [Wirtz et al. (2019)].

This work focuses on the assessment of business models from both a provider and consumer perspective using the currently planned residential district of Hassel, Germany, as a case study.

### Methods

This work extends classical optimization-based energy system models to account for individual consumer behavior and the contractually governed interaction between consumers and energy providers. Different contract structures with respect to costs and profits of consumers and energy providers, as well as their deviation from an overall social welfare optimum, are investigated. Furthermore, this work also considers legal regulations and federal funding options such as price ceiling, CO<sub>2</sub> taxation and subsidization of investments into climate-friendly technologies, which are frequently analysed in the literature [Schütz et al. (2017), Pinto et al. (2020), Pina et al. (2021)]. In contrast to the state-of-the-art approaches, however, this work analyzes their impact on individual decision-making, total system costs and resulting CO<sub>2</sub> emissions for both, central-planner and multi-agent optimization models.

In particular, an energy system optimization model for the whole district is formulated and subsequently split into several consumer and a provider model in order to circumvent the solving of a computationally intractable bilevel model [Dempe et al. (2015)]. At the interface, an energy contract, i.e. concise energy prices are assumed. For these predefined energy prices, the consumer models are run yielding their energy demands depending on the assumed price constellation. Then both, the prices and the demands are fed into the energy provider model. This analysis is performed for 1681 different price constellations applied to 51 different consumers and one provider. Afterwards, the results of the respective contracting model are benchmarked against the central planner model of the whole district which defines the social-welfare optimum and is solved using cutting-edge time series aggregation techniques for maintaining computational feasibility [Hoffmann et al. (2022)].

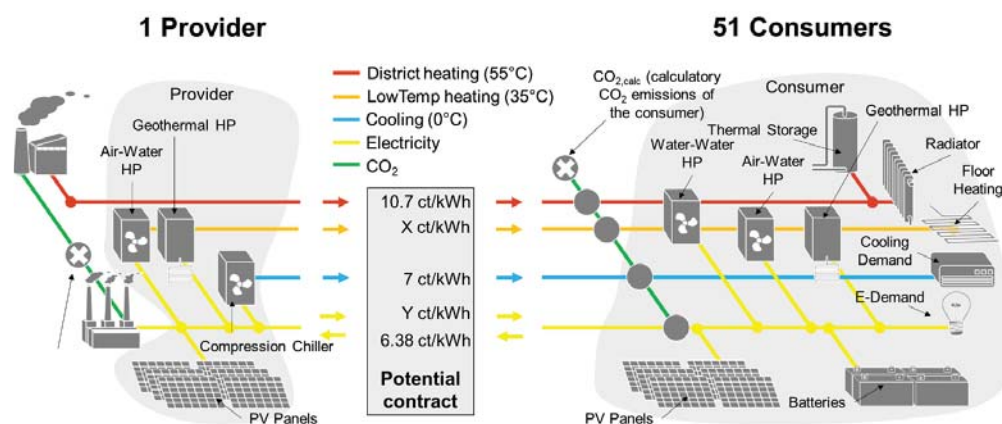


Figure 1: Decomposition of the Optimization Model into a Provider and 51 Consumer Models Interacting by a Fixed Contract



In a second step, different regulation schemes are imposed on the consumers and the district system operator. These regulations comprise subsidies for energy efficient technologies such as heat pumps on the one hand and carbon taxes on the other hand, that are imposed on either the consumers, the energy provider or both of them. Then, the sensitivities for different price constellations between energy consumers and the energy provider are re-run and the impact of the regulations on the individual behaviour of the market participants as well as on the central-planner model are investigated.

## Results

The results comprise approximately 400.000 single (sub-)system optimizations and show a distinctly sensitive reaction of consumers on changing prices or regulation schemes if they have a large number of system options such as installing photovoltaic panels on their own. Interestingly, the demand for different energy sources such as low-temperature heat and electricity may suddenly change for slight price changes as the consumers may be incentivized to move to an economically more convenient alternative. This, in turn, leads to sudden tipping points in energy demands which, in turn, may lead to strong deviations from a social-welfare optimum of up to 18% of total annualized costs, i.e. non-aligned incentives may result in a system layout and energy consumption behavior that is 18% more expensive than predicted by a central-planner model.

For the regulations, a similar impact can be observed. Here, poorly defined regulations may have little impact on the overall behaviour. Especially CO<sub>2</sub> taxation alone prove to be not very effective and drove costs without setting the incentives to invest into carbon neutral technologies. In contrast to that, carrot-and-stick combinations of subsidies for carbon neutral technologies and CO<sub>2</sub> taxes on the other hand prove to be very effective with respect to multiple criteria, among which are CO<sub>2</sub> reduction, little impact onto the overall social welfare and system costs and the individual costs of the system stakeholders.

## Conclusions

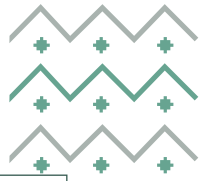
The results imply, that in district systems, contractually governed constant energy prices may set wrong incentives for energy consumers and providers. Furthermore, these contracts always lead to more or less suboptimal deviations from the macro-economic optimum and similar phenomena can be observed for additional regulations.

In this context, CO<sub>2</sub> taxes for the energy consumers and subsidies for climate-friendly technologies have been proven to be a preferable regulation scheme, whereby, however, a price ceiling for the provider's energy prices should be introduced in order to avoid a shift of the energy consumers towards less climate-friendly supply options. This implies that well-designed and financially balanced regulation schemes should include subsidization on the one, but taxation of deviating behavior or price ceiling on the other hand. Lastly, this work illustrates that, at times of rising energy prices, more efficient, but slightly more expensive technologies should be favored in the medium term.

## References

1. Dempe, S., V. Kalashnikov, G. A. Pérez-Valdés and N. Kalashnykova (2015). *Bilevel Programming Problems: Theory, Algorithms and Applications to Energy Networks*. Heidelberg, Springer Berlin, DOI: <https://doi.org/10.1007/978-3-662-45827-3>.
2. Hoffmann, M., L. Kotzur and D. Stolten (2022). "The Pareto-optimal temporal aggregation of energy system models." *Applied Energy* **315**: 119029, DOI: <https://doi.org/10.1016/j.apenergy.2022.119029>.
3. Pina, E. A., M. A. Lozano and L. M. Serra (2021). "Assessing the influence of legal constraints on the integration of renewable energy technologies in polygeneration systems for buildings." *Renewable and Sustainable Energy Reviews* **149**: 111382, DOI: <https://doi.org/10.1016/j.rser.2021.111382>.
4. Pinto, E. S., L. M. Serra and A. Lázaro (2020). "Optimization of the design of polygeneration systems for the residential sector under different self-consumption regulations." *International Journal of Energy Research* **44**(14): 11248-11273, DOI: <https://doi.org/10.1002/er.5738>.
5. Schütz, T., M. H. Schraven, S. Remy, J. Granacher, D. Kemetmüller, M. Fuchs and D. Müller (2017). "Optimal design of energy conversion units for residential buildings considering German market conditions." *Energy* **139**: 895-915, DOI: <https://doi.org/10.1016/j.energy.2017.08.024>.
6. Wirtz, M., L. Kivilip, P. Remmen and D. Müller (2019). "Bidirectional low temperature networks in urban districts: A novel design methodology based on mathematical optimization." *Journal of Physics: Conference Series* **1343**(1): 012111, DOI: 10.1088/1742-6596/1343/1/012111.
7. Wirtz, M., L. Kivilip, P. Remmen and D. Müller (2020). "5th Generation District Heating: A novel design approach based on mathematical optimization." *Applied Energy* **260**: 114158, DOI: <https://doi.org/10.1016/j.apenergy.2019.114158>.





## Contribution to improving the energy performance of a hotel in Tangier - Morocco

M. Ahachad, ETTE, FST of Tangier, Abdelmalek Essaadi University, Tetouan-Morocco, +212662272483, mahachad@uae.ac.ma

F. Akzoun, ETTE, FST of Tangier, Abdelmalek Essaadi University, Tetouan-Morocco, firdaous.akzoun@gmail.com

Z. Romani, National School of Architecture, Tetouan – Morocco, +212653784137, romani.zaid@gmail.com

M. Mahdaoui, ETTE, FST of Tangier, Abdelmalek Essaadi University, Tetouan-Morocco, +212662562909, mmahdaoui@uae.ac.ma

### Overview

Morocco, very weakly endowed with conventional energy resources, highly dependent on the outside for its energy supply. This Energy dependence is thus estimated at 93.61% in 2013 [1]. Furthermore, annual energy consumption per capita increased from 0.30 toe per capita in 1990 to 0.55 toe per capita in 2016 [2]. The transport and building sectors are the biggest energy consumers in Morocco and together account for more than 60% of total final energy consumption [1]. As well as, the building sector accounts for 33% of the country's total energy consumption, of which 25% for the residential sector and 8% for the tertiary sector [1]. Besides, the tourism sector accounts for one third of tertiary sector consumption, due to growth in electricity and air-conditioning consumption. Tourism is one of the major vectors of the Moroccan economy which is destined to gain even more importance to support economic development.

Tourist establishments are considered among the most energy-consuming buildings due to the high energy consumption for lighting, air conditioning, heating and hot water production in order to provide services to customers and guarantee their internal comfort [2]. In fact, air conditioning and lighting in the hotel sector remain highly dominant, accounting for 21% and 20% respectively, followed by the production of domestic hot water which represents 17%, the rest of the energy consumption distributed between the heating (14%), kitchens (12%) laundries (6%) and others (10%). In addition, the energy consumption varies considerably between different types of hotels depending on the size of the hotel, the class / category, the number of rooms, the customer profiles, the location, and the types of services / activities. In general, the energy required for a hotel building is intended for thermal energy needs and varies between 40 and 70%, which implies a high energy consumption. In particular, the installation of air conditioning can represent up to 50% of the total energy installations of the building, a poorly designed heating system, where maintenance operations are not carried out, can generate losses in thermal energy of 30 to 40%. As a result, improving the competitiveness of the tourism sector requires progressive reduction of operating costs, especially those of major importance, such as energy and water costs. In this context, the HVAC system is the major consumer of energy in commercial buildings, particularly in the hotel sector [3], therefore hotel owners aim to reduce the energy bill in this sector. Besides, energy efficiency measures in the hotel industry include air conditioning systems [3], the thermal performance of the building envelope and the production of water heaters.

In the present study, an energy, environmental and economic study for a hotel building is carried out specifically to assess the potential in reducing energy consumption, energy demand, and carbon emissions associated with the hotel building sector. First, a briefly comparative study of two heating and cooling systems (VRV and GRL) is outlined. Then, the passive analysis for assessing the impact of three energy efficiency improvements is described and discussed. Finally, an analysis and comparison of the two energy systems for the production of domestic hot water is studied using an energy, economic and environmental study.

### Methods

#### II.1 Building description

The hotel studied (Figure 1) located in the business and leisure district of Tangier, the hotel's total surface area amounts to 12508.6 m<sup>2</sup>, it is endowed with a ground floor, a mezzanine and ten floors including 220 rooms in total. The ground floor consists of a wing containing the offices, the reception and the shop, and a wing including the bar, the show cooking and the customer counter. While, the mezzanine has a conference center with a capacity of nearly 100 participants. The different occupancy rates of the zones are fixed as follows 0.055: person/m<sup>2</sup> for the rooms (Area = 36 m<sup>2</sup>), 0.6116 person / m<sup>2</sup> for the conference room (Area =114 m<sup>2</sup>), 0.107 person / m<sup>2</sup> for the office (Area = 93 m<sup>2</sup>).

The occupancy schedule of a room is shown in Figure 3, The internal heat gains are 0.9 MET (58W/m<sup>2</sup>) for persons, 323 (W) for Minifreezer, 90 (W) for TV LCD, and 11.9 (W/m<sup>2</sup>) for lighting appliances. DesignBuilder software, based in the engine EnergyPlus calculation, is used in this study.



Figure 1: Hotel of Tangier





### II.2 Economic study: Life Cycle Cost Analysis -Method

The financial analysis in this article adopts the life cycle cost method, the life cycle cost (LCC) analysis method is the most commonly accepted to assess the economic benefits of energy conservation projects over their lifetime. Typically, the method is used to evaluate at least two alternatives of a given project. The LCC amount for each alternative can be computed by projecting all the costs (including costs of acquisition, maintenance, and operating the energy systems related to the energy-conservation project). LCC can be estimated based on the initial cost IC and the annual cost AC as follows [55]:

$$LCC = IC + USPW(d, N) \times AC$$

The uniform-series present worth factor (USPW) can be expressed as follows:

$$USPW(d, N) = \frac{1-(1+d)^{-N}}{d} \text{ where } N \text{ and } d \text{ are respectively the lifetime and the discount rate.}$$

### II.3 Assessment of the HVAC system

The electricity is the main energy source used in heating and air conditioning systems in Moroccan tourist establishments, the average consumption recorded is 2.223.300 kWh/year/hotel. In fact, a better select of air conditioning technologies for hotel establishments can have a significant effect on electrical consumption, also improving environmental performance generally, in consequence reducing operational costs. In this part, we performed a comparative study between two heating and cooling systems, the Variable Refrigerant Volume System (VRV) and chilled water system (CWS) using the Life Cycle Cost method to determine the most economically efficient system for the hotel. First, we calculated the total heating and cooling load using the DesingBuilder software, we obtained a total cooling load of 1234.27 kW and a heating load of 448.96 kW. This amount of information was sufficient to begin the process of sizing these two systems, the sizing of each system is done by the selection of the indoor units and the outdoor units as well as the sizing of the pipes and the choice of accessories. In order to compare the two air-conditioning systems, an economic study is carried out to quantify the investment costs of the systems including maintenance and operating costs.

## Results and conclusions

The present study consists firstly to comparing two air conditioning and heating systems for the hotel building. In order to determine the most economical, technologically reliable and least environmentally impacting system. Secondly, to evaluate the energy, economic and environmental performance of the two systems of domestic hot water production of the studied hotel and their combinations with the solar collectors. This analysis shows that the Variable Refrigerant Volume system is the most economical, and the most adopted for the hotel. This choice implies a net investment of 650 000 US\$, its environmental pollution is estimated approximately 85548.2 kg-CO<sub>2</sub> annually. Several recent studies have proposed solutions to improve the energy efficiency of the hotel sector, in this work we studied the effect of three improvements on the reduction of hotel needs. 3rd SC of natural ventilation leads to the reduction of energy needs of the hotel is about 27% annual. Then, the 2nd SC of Glazing Film reduces by approximately 36% of the annual needs compared to the basic building. Finally, the cool roof of high reflectance and emissivity coefficients leads to a reduction in annual needs of 28% annually. From the environmental perspective, these three scenarios lead to a reduction of almost 28%, 28% and 35% of CO<sub>2</sub> emissions. It can be noticed that the three improvements have significant energy savings with a life cycle cost slightly lower than that of the standard building, except the second SC of PF which presents a higher LCC compared to these of the building.

It has been observed that the usage of a heat pump as a technology for the production of hot water in the hotel sector results the lowest primary energy consumption, compared to a gas boiler, about 47.5% reduction in annual consumption. Although boiler systems consume more energy than air-source heat pumps, the former produce smaller amounts of CO<sub>2</sub> emissions than the latter 21.2% more CO<sub>2</sub> emissions than the gas boiler. From an economic perspective, the life cycle method for the various technologies, implies that the global savings on energy bills generated by the use of heat pumps will amount to 13110 US\$ compared to a boiler. In addition, the payback period of investments for a heat pump combined with a solar installation varies from 3 to 4 years, and it is lower compared to that of a boiler plant combined with solar collectors. As well as, the heat pump and its combination with solar results in high NPV values compared to a combined system with a boiler.

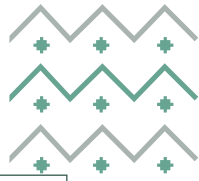
## Results and conclusions

[1] <https://www.iea.org/statistic.03-03-2018>

[2] P.Bohdanowics, A. Churie kallhauge, I.Martinac, Energy Efficiency and conservation in hotels towards sustainable tourism, 4th International Symposium on Asia Pacific Architecture, Hawai'I, April 2001.

[3] M. FadzliHaniff, H. Selamat, R. Yusof, S. Buyamin, F. ShamIsmail, 'Review of HVACscheduling techniques for buildings towards energy-efficient and cost-effective operations' Renewable and Sustainable Energy Reviews, 27 (2013) 94-103.





## **IMPACT OF ENERGY LABELS ON SELECTING HOUSES OF CONSUMERS: VALIDATION BY LOGISTIC REGRESSION ANALYSIS**

Mieko FUJISAWA, Kanazawa University, +81-76-264-5408, fujisawa@staff.kanazawa-u.ac.jp

### **Overview**

Energy labels express the energy efficiency level of houses and help consumers' decision makings. Many studies have verified that energy labels promote consumers' select of pro-environmental products (e.g., Grankvist et al, 2004, Bjerregaard and Møller, 2019). The energy labels are set to be displayed mandatorily in Japanese real estate advertisements soon. Effective energy labelling methods and designs need to be studied before the government mandates energy labelling.

This study aims to examine whether providing information on energy efficiencies of houses for consumers in some way such as energy labels affects their decision makings. Furthermore, by clarifying the effects of different information methods (framing), we intend to make specific suggestions on the design of energy labels.

### **Methods**

Experiment participants were extracted from a survey panel of an Internet research firm by two-stage random sampling. We randomly classified the subjects, using the control experiment method, into four groups: control group with no information disclosed, treatment group 1 with only text information, treatment group 2 with only label information, and treatment group 3 with both information. In addition, in order to identify differences in framing effects between buyers and prospective buyers of houses, we further classified each group into two, making a total of eight groups.

The preliminary survey was conducted from March 18 to 24, 2022, and the experiment from March 25 to 30, 2022. The sample size was 206 for each group, a total of 1,648. The main survey asked 19 questions, including a question about what is important to respondents when purchasing a house.

The experiment was that 12 photos were displayed on the screen as candidates for houses that match the subjects' desired location, and subjects were asked to select the most desirable house from these photos. For the house they chose from the 12 photos, the subjects in each group select one of three options varying in energy efficiency level, price, etc. These steps are very similar search of consumers for houses, and we set up this experiment based on Sussman et al. (2021).

Through above experiment, we verified what kind of framing would encourage subject to choose energy efficient houses. This also allows us to measure difference in effects of information framing between buyers and prospective buyers of houses. This study applied logistic regression analysis to a dataset obtained from the experiment as follows.

$$Y^* = \beta_0 + \sum_{i=1}^m \beta_i X_i + \varepsilon$$
$$Y = \begin{cases} 1 & (Y^* > 0) \\ 0 & (Y^* \leq 0) \end{cases}$$

where the dependent variable  $Y^*$  means whether select an energy-saving house or not. Concretely,  $Y=1$ : subject selected the most energy-saving house from three options varying energy efficiency level, while  $Y=0$ : means that did not select energy-saving house.  $\beta$  is a regression coefficient,  $X_i$  ( $i = 1, \dots, m$ ) is the  $i$ th independent variable, and  $\varepsilon$  is a random error term.



## Results

The results of analysis showed two important implications: one indicated the importance of disclosing information on energy efficiency of houses, another suggested necessity of devising information disclosure to supplement inexperience.

Table 1 shows the result of logistic regression analysis, and the framing of information were verified to important be since all treatment group are statistically significant. These are also very higher odds ratio than other variables. The fact, all treatment group were accepted at a significance level of 1% based on the control group proves the significance of information disclosure.

Moreover, buyer dummy was statistically significant, this means that presumed to be the result of the purchaser's actual experience such as the running cost of a detached house and the indoor temperature. From this, it was suggested that it is important to consider the display of advertisements such as running costs. As for the method of information disclosure, it is important to disclose it in a way that is accompanied by the understanding of consumers.

Table 1 The result of logistic regression analysis

	Coef.	Std. Err.	z	Odds Ratio
Treatment 1	1.7934 ***	1.1447	9.4200	6.0096
Treatment 2	1.4683 ***	0.8285	7.6900	4.3417
Treatment 3	1.7962 ***	1.1461	9.4400	6.0264
Buyer dummy	0.2827 *	0.2204	1.7000	1.3267
Emphasis on insulation	0.3678 ***	0.1887	2.8200	1.4446
Knowledge of insulation	0.1128 **	0.0492	2.5700	1.1194
Knowledge of environment	0.0849 *	0.0513	1.8000	1.0886
Interest in environment	0.2629 **	0.1455	2.3500	1.3007
Pro_environment	0.2554 ***	0.1259	2.6200	1.2910
Education	0.0522	0.1125	0.4900	1.0536
Men dummy	0.0010	0.1469	0.0100	1.0011
Age	0.0083	0.0109	0.7600	1.0083
Married dummy	0.0364	0.1968	0.1900	1.0371
Childdummy	-0.0699	0.1760	-0.3700	0.9324
Family size	0.0584	0.1409	0.4400	1.0601
Household income	0.0530	0.0460	1.2200	1.0544
Detached house dummy	-0.1690	0.1402	-1.0200	0.8445
cons	-4.5726 ***	0.0067	-7.1000	0.0103
Number of obs		1,471		
Log likelihood		-876.7505		
Pseudo R2		0.0923		

Note: Superscripts \*\*\*, \*\*, \* denote significance at the level of 1%, 5%, 10%, respectively.

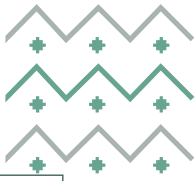
## Conclusions

From results of the experiment, it was confirmed that disclosing energy efficiency information of houses in some way in real estate advertisements is effective in encouraging consumers to choose energy-efficient houses. It was also suggested that when disclosing information about energy efficiency of houses, it is also important to present it in a way that would be better understood by consumers depending on their respective situations.

Mandatory disclosure of residential energy efficiency information, which has been postponed in Japan, would be necessary as soon as possible. Prior to legally mandating the disclosure of information on energy efficiency, it would be necessary to introduce some kind of system to encourage the disclosure of information.

## References

- Grankvist, G., Ulf Dahlstrand, U., & Biel, A. (2004). The impact of labelling on consumer preference: negative vs. labels. *Journal of Consumer Policy*, 27, 213–230.
- Bjerregaard, C., & Møller, N. F. (2019). The impact of EU's energy labeling policy: An econometric analysis of increased transparency in the market for cold appliances in Denmark. *Energy Policy*, 128, 891–899.
- Sussman, R., Conrad, S., Kormos, C., Park, C., & Cooper, E. (2021). Context and meaningfulness in energy efficiency labeling: Real estate listings. *Journal of Environmental Psychology*, 78.



TOWARDS SUSTAINABLE TRANSPORTATION: THE DEVELOPMENT OF  
HYDROGEN TRAIN IN SAUDI ARABIA

HAMAD ALMUJIBAH

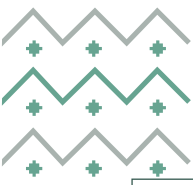
DEPARTMENT OF CIVIL ENGINEERING, COLLEGE OF ENGINEERING, TAIF  
UNIVERSITY, P.O. BOX 11099, TAIF 21944, SAUDI ARABIA;  
[HMUJIBAH@TU.EDU.SA](mailto:HMUJIBAH@TU.EDU.SA)

ABSTRACT

Saudi Arabia has planned to depend on the clean fuel sector in the coming decades, which is in line with Vision 2030, as well as to become a global supplier of Hydrogen and to play a leading role in all areas of energy, not just oil. Moreover, a series of hydrogen-based programs are aimed at making the transportation sector more sustainable, including the use of technologies based on hydrogen fuel cells for trains. In this case, the Hydrogen train fuel cells convert hydrogen-rich fuel into electricity through a simple chemical process, which consists of a positive electrode (anode) in electrical circuit that has a negative electrode (cathode) and an electrolyte or conductive medium. The stored hydrogen passes through the anode, where it splits into electrons and protons. Then, the electrons enter through a circuit that generates an electric charge and may be stored in lithium batteries or sent directly to the train's electric motor. The remaining part of the hydrogen molecule reacts with oxygen at the cathode and turns into the only waste product, which is water. The Oxygen can be separated from water by using an electric current, which can be generated from renewable energy sources such as wind and solar energy. This paper is aimed to determine the operator cost of constructing a Hydrogen train line through a mathematical calculations based on Microsoft Excel, which includes the infrastructure and rolling stock costs. In this case, a gravity demand model will be used to determine the forecasting travel demand for the case study of the North-South Rail line, connecting Riyadh to Qurayyat for a distance of 1,257 kilometres. It is a function of independent variables such as population, GDP per capita, mean travel speed, mean fare, etc.

**Keywords:** Hydrogen Train, Operator Costs, Renewable Energy Resources, Gravity Demand Model, Sustainable Transportation; Saudi Arabia.





## INVESTIGATING THE ECONOMIC GRANULARITY GAP IN THE MODELLING OF BATTERY ELECTRIC VEHICLES: AN ANALYSIS FROM A POWER-SYSTEM AND A USER-CENTRIC PERSPECTIVE

Fabia Miorelli, German Aerospace Center (DLR), Institute of Networked Energy Systems, Curierstr. 4, 70563 Stuttgart, Germany, +49 711 6862 8456, fabia.miorelli@dlr.de

Hans Christian Gils, German Aerospace Center (DLR), Institute of Networked Energy Systems, Curierstr. 4, 70563 Stuttgart, Germany, +49 711 6862 477, hans-christian.gils@dlr.de

Patrick Jochem, German Aerospace Center (DLR), Institute of Networked Energy Systems, Curierstr. 4, 70563 Stuttgart, Germany, +49 711 6862 687, patrick.jochem@dlr.de

### Overview

Strategies for decarbonising large-scale energy systems have a decisive impact on future energy costs and must, therefore, be thoroughly evaluated. Energy systems optimisation models (ESOMs) are frequently employed in the analysis and planning of energy systems. However, their scope and detail in terms of space, time, technologies, and economic sector can vary widely. Due to computational limitations, they can either have a high-resolution scope or a broader less detailed scope in the spatial and temporal dimensions. This difference between modelling scopes has been labelled with the term granularity gap [1]. Solutions to address this modelling gap include boosting the resolutions of the established optimisation model and various types of model coupling [1]. Specifically, the economic granularity gap refers to the modelling of discrepancies between a system-cost minimising approach from ESOMs and a micro-level simulation approach, where the behaviour and interactions of individual agents follows their own individual strategies like in a real-world case. Operating decisions of private actors are indeed having an ever increasing influence on the energy system [2, 3]. However, ESOMs are falling short in including such actors and their decisions in the modelling approach. Against this background, this work analyses whether the economic granularity gap in the case of battery electric vehicles (BEVs) significantly affects the system design and operation that results from an ESOM. To illustrate these effects on the charging profiles of BEVs, results from a ESOM with optimised charging from an overall system's perspective are compared to that of a model that captures the economic rationality of time-varying tariffs and user-centric charging decisions for a case study in Germany.

### Methods

Instead of extending existing models, the identified granularity gap in the case of BEVs is analysed by comparing results from the energy systems optimisation model REMix [4] with a user-centric optimisation based on the VencoPy model [5].

To analyse the influence of optimised charging under consideration of different time-varying tariffs for different household types, the VencoPy framework is used [5]. VencoPy calculates boundary conditions for the charging behaviour and of possible vehicle-to-grid potentials based on mobility data and techno-economic assumptions. This allows to investigate the increased demand for electricity due to the electrification of passenger road transport. Figure 1 shows a schematic representation of the model building blocks. Based on driving profiles of typical households as well as on technical data and assumptions about BEV, boundaries for minimum and maximum states of charge (SoC) of the vehicle batteries are calculated. From this, hourly resolved demands for uncontrolled charging, as well as load shift potentials for controlled charging can be derived for different BEV fleets. The VencoPy framework was used in different projects [5, 6, 7]. Among others, it was applied to the German transport survey "Mobility in Germany" to investigate the influence of BEV on the future load shifting potential and its impact on the German power system. The framework was applied in a case study involving two recent German national travel surveys [8, 9] to exemplify the implications of different mobility patterns of motorised individual vehicles on load shifting potential of BEV fleets [5]. Exemplary results of the framework include the distance travelled per hour, the connection availability, and the upper and lower limit for the battery SoC. Based on different decision methods, charging and discharging profiles can be calculated. More recently the framework has been expanded to also allow tariff-based optimisation by additionally taking time-varying prices into account in the charging control mechanism.



Figure 1: VencoPy model workflow components.

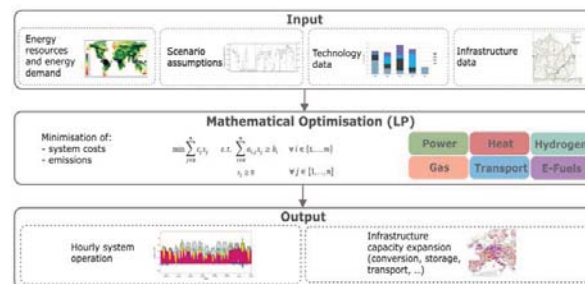
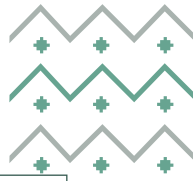


Figure 2: Structure of the REMix framework.





ESOMs represent a widely used technique to determine decarbonisation pathways to assist policymakers in the definition of future energy systems. The REMix energy system modeling framework provides a linear framework with high spatial and temporal resolution to analyse energy system transition scenarios [4]. After initially being restricted to the power sector [8], the framework has progressively improved to incorporate the flexible coupling to the heating, industry and transportation sectors, through a multi-modal configuration that enables the use of electricity from variable renewable energy sources in all sectors. Considering boundary conditions, such as the development of demand or the flexibility of generators and consumers, REMix can be used to evaluate the interaction between all technologies in hourly resolution and to determine the minimum-cost expansion and operation of the energy supply system under consideration (Figure 2). Numerous models of the German and European energy system with various foci have been modeled and examined in the past using the framework, as well as energy systems of other countries [10, 11, 12].

## Results

Granularity gaps often emerge across several model dimensions in energy systems modeling. To investigate if the economic granularity gap in the case of BEVs significantly affects system designs that result from an energy system optimisation model, the results from the REMix framework and a user-centric optimisation in the VencoPy model are compared.

The results provide an assessment of how the representation of charging profiles and flexibility of BEVs might affect energy systems optimisation results. Both frameworks are applied to different scenarios for controlled charging of BEV fleets in Germany. ESOMs, which are typically used to study cost-minimal transformation pathways, assume a perfect behaviour of market participants from a central planner's perspective. They thus neglect the decision-making of individual market participants, which also influences the demand-side flexibility in the case of BEVs [13]. The results also show how the difference between power-system and user-centric optimal charging decisions can lead, for example, to lower electricity imports and transmission grid expansion, a different usage of flexibility from the system perspective, and different system costs.

## Conclusions

Models are applied to gain insights into possible futures of the energy system, e.g., to serve for decision support in energy policy and industry. Drafting ideal system designs by energy systems optimization models provides templates to navigate possible system transformation. However, discrepancies between the optimal and the real-world occur and granularity gaps arise across several model dimensions [1]. Moreover, electricity tariffs are a main economic driver for private consumer investments in distributed energy resources (DERs), such as photovoltaic (PV), electric vehicles and storage systems [14]. Utilities' rate designs and policy makers' decisions around different tariff components (volumetric rates, demand charges, feed-in compensations, etc.) affect the economic viability of DER technologies, fostering or discouraging behind-the-meter investments [15]. Including decentralised user-centric decisions in energy systems optimisation models can provide a starting point to include different perspectives in energy systems transformation pathways as well as allowing a more proper identification of appropriate regulatory regimes, as for example incentives for system alignment of decentralised actors.

## References

- [1] Cao et al. (2021) *Bridging granularity gaps to decarbonize large-scale energy systems - The case of power system planning*. Energy Science and Engineering. Wiley. doi: 10.1002/ese3.891. ISSN 2050-0505.
- [2] Siohansi (2016), *Retail electricity tariff and mechanism design to incentivize distributed renewable generation*. Energy Policy 2016;95:498–508. <https://doi.org/10.1016/j.enpol.2015.12.041>
- [3] Picciariello et al. (2015), *Distributed generation and distribution pricing: Why do we need new tariff design methodologies?* Electr Power Syst Res 2015;119:370–6. <http://dx.doi.org/10.1016/j.epsr.2014.10.021>
- [4] Y. Scholz, *Renewable Energ. Based Electricity Supply at Low Costs. Development of the REMix Model and Application for Europe*, University of Stuttgart, Dissertation, 2012-06-01, <https://doi.org/10.18419/opus-2015>. Stuttgart.
- [5] Wulff et al. (2021), *Vehicle Energy Consumption in Python (VencoPy): Presenting and Demonstrating an Open Source Tool to Calculate Electric Vehicle Charging Flexibility*. Energies, MDPI. 2021; 14(14):4349. <https://doi.org/10.3390/en14144349>
- [6] Luca de Tena (2014). *Large Scale Renewable Power Integration with Electric Vehicles. In Long Term Analysis for Germany with a Renewable Based Power Supply*, Dissertation. University of Stuttgart: Stuttgart, Germany, 2014.
- [7] Luca de Tena et al. (2018). *Impact of electric vehicles on a future renewable energy-based power system in Europe with a focus on Germany*. Int. J. Energy Res. 2018, 42, 2670–2685.
- [8] Infas, DLR, IVT and Infas 360: *Mobilität in Deutschland—MiD. Ergebnisbericht. Struktur—Aufkommen—Emissionen—Trends*. Available online: [http://www.mobilitaet-in-deutschland.de/pdf/infas\\_MiD2008\\_Abschlussbericht\\_L.pdf](http://www.mobilitaet-in-deutschland.de/pdf/infas_MiD2008_Abschlussbericht_L.pdf)
- [9] Nobis, C.; Köhler, K. *Mobilität in Deutschland—MiD Nutzerhandbuch*. Study by Infas, DLR, IVT und infas 360 on behalf of the German Minister for Transportation and Digital Infrastructure (FE-Nr. 70.904/15). Bonn, Berlin. Available online: [http://www.mobilitaet-in-deutschland.de/pdf/MiD2017\\_Nutzerhandbuch.pdf](http://www.mobilitaet-in-deutschland.de/pdf/MiD2017_Nutzerhandbuch.pdf)
- [10] H.C. Gils, Y. Scholz, T. Pregar, D. Luca de Tena, D. Heide, *Integrated modelling of variable renewable energy-based power supply in Europe*, Energy 123 (2017) 173e188, <https://doi.org/10.1016/j.energy.2017.01.115>.
- [11] H.C. Gils, S. Simon, *Carbon neutral archipelago e 100% renewable energy supply for the Canary Islands*, Appl. Energy 188 (2017) 342e355.
- [12] H.C. Gils, S. Simon, R. Soria, *100% renewable energy supply for Brazil: the role of sector coupling and regional development*, Energies 10 (11) (2017) 1859.
- [13] A. Ensslen, *Sozioökonomische Analysen zur Elektromobilität unter Berücksichtigung von Nutzungserfahrungen*, Dissertation, Karlsruher Institut für Technologie (KIT), <https://publikationen.bibliothek.kit.edu/1000104412>.
- [14] Kaschub et al. (2016). *Solar energy storage in German households: profitability, load changes, and flexibility*. Energy Policy 98, 520–532.
- [15] Kazhamiaka et al. (2017). *On the Influence of Jurisdiction on the Profitability of Residential Photovoltaic-Storage Systems*. Energy Policy 107, 428–440.







## ***CHOOSING TO DIET: THE IMPACT AND COST-EFFECTIVENESS OF CHINA'S VEHICLE OWNERSHIP RESTRICTIONS***

Antung Liu, Indiana University O'Neill School of Public and Environmental Affairs, USA, aaliu@indiana.edu  
Rubal Dua, King Abdullah Petroleum Studies and Research Center (KAPSARC), KSA, rubal.dua@kapsarc.org  
Wei-min Hu, National Chengchi University, Taiwan, weiminhu@nccu.edu.tw  
Arthur Lin Ku, Indiana University O'Neill School of Public and Environmental Affairs, USA, alku@iu.edu

### **Overview**

The transportation sector is the fourth largest emitter of greenhouse gases (GHGs), linked to rising global temperatures. Passenger cars that run on petroleum-based fuels account for about 40% of all transportation emissions. The global expansion of the passenger car fleet has been a main driver of petroleum-based fuel consumption and GHG emissions. Pollution, congestion, and accidents are some of the local externalities associated with rising passenger car use.

Voluntary efforts by countries have emerged as one of the main pathways for addressing these externalities. One of the voluntary efforts being undertaken in China, the world's largest GHG emitter, is vehicle ownership restrictions (VOR), which sets a limit on the number of new license plates issued each year. Since VOR limits the growth of car fleet size, it has the potential to assist China in significantly reducing its carbon emissions. Understanding the impact and cost-effectiveness of VOR policies in limiting car fleet size, fuel consumption, and GHG emissions is crucial for both understanding the scope of China's voluntary efforts and informing policymakers in other parts of the world who are considering the adoption of similar policies.

### **Methods**

We apply synthetic control, regression discontinuity, and dynamic panel analysis techniques on new car registrations and usage data in Chinese cities. In particular, we use regression discontinuity and synthetic control techniques to quantify the impacts of ownership restrictions on new car sales as well as fuel consumption rate for the new car fleet. We next estimate the effect of vehicle ownership restrictions on the average annual kilometers travelled per car for new cars. To examine this possibility, we used dynamic panel analysis technique to estimate the dependence of annual kilometers travelled per car on the total number of cars in the city.

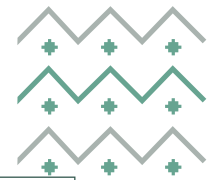
### **Results**

We find that ownership restrictions in Chinese cities have had large impacts. In particular, between 2011 and 2015, ownership restrictions decreased new car sales in cities implementing them by about 72%, while decreasing gasoline consumption and tailpipe-GHG emissions by about 50%. In absolute terms, 5.3 million new car purchases and 7 million metric tonnes per year of tailpipe-GHG emissions were avoided by 2015 as a result of these ownership restrictions. To put things in perspective, the total annual car sales in Japan, the third largest automotive market in the world, were lower than 5.3 million, while thirty countries worldwide had total annual carbon dioxide emissions from fuel combustion below 7 million metric tonnes. Cost-effectiveness evaluation suggests these large impacts occur at a very high cost, comparable to the price of gasoline in China, though within the range of estimates on the cost of externalities avoided.

### **Conclusions**

The findings hold relevance for policymakers worldwide who might be considering restrictions on car sales for addressing automobile-related externalities. The results have implications for future oil demand, because China, also the world's largest consumer of gasoline, has taken voluntary measures to slow its demand growth. Furthermore, our results are important because they illustrate a strategy of China, the world's largest producer of GHG emissions, to decrease its future emissions growth. Our analysis can also support studies that examine whether China will meet its Paris Agreement pledges.





## WHAT DO PEOPLE THINK ABOUT THE WIRELESS ROADWAY CHARGING SYSTEM FOR ELECTRIC VEHICLES?

Mira Simunic, The University of Auckland, +6493737599, msim529@aucklanduni.ac.nz  
Mingyue Selena Sheng, The University of Auckland, +6493737599 ext. 82159, m.sheng@auckland.ac.nz  
Le Wen, The University of Auckland, +6493737599 ext. 87594, l.wen@auckland.ac.nz

### Overview

Along with the knowledge that typical EV acceptance barriers include driving range and charging times, technological advancements in wireless charging roadways or dynamic inductive power transfer (DIPT) roadway systems have been emanating. The technology can transfer power to EVs over an air gap without physical contact, which enables EVs to be energised wirelessly while travelling in motion via embedded pads/transmitters beneath the roadway and receivers under the vehicles (Nagendra *et al.*, 2014; Sheng *et al.*, 2020). DIPT charging can be offered to light-duty, medium to heavy-duty vehicles, and/or other fleets, so they can always be on the move. This technology can potentially mitigate previously listed barriers that discourage the consumer from purchasing an EV. At present, charging at public charging stations in New Zealand can take approximately 30 minutes. Dynamic wireless charging, on the other hand, offers a more convenient experience for the consumer regarding driving range and charging time (Sun *et al.*, 2018). Additionally, this technology can remove the cumbersome task of plugging in and lower operating costs and the cost of EV batteries, among others. Researchers from the University of Auckland (UoA) explain that installing IPT is a potential game changer for EV uptake due to its potential to alleviate barriers other than upfront costs, such as driving range anxiety, or the inconvenience of interrupting a journey to plug in and recharge (Poland, 2021). Nonetheless, providing a viable DIPT system remains challenging, especially given the potential uncertainties of the existing/prospective EV consumers. Both the technology around EVs themselves and their associated charging options remain largely unfamiliar to the general population. Gaining a better understanding of the consumer decision-making process and preference for EVs and the associated charging options is crucial if New Zealand continues to increase EV uptake. Hence, this research aims to understand the perceived economic and environmental benefits of DIPT technology or named dynamic wireless charging, and how that might impact EV adoption in New Zealand. At the hand of discrete choice modelling (DCM), a better understanding of how consumers value dynamic charging capabilities was possible. Multinomial Logit (MNL), Heteroscedastic Logit (HL), and Mixed Logit (MXL) models were fitted to stated preference data. Furthermore, DCM allowed the willingness to pay (WTP) for dynamic charging capability to be measured indirectly. The main finding was indeed that dynamic charging capability has a significant positive impact on vehicle choice.

### Methods

A survey was designed to understand how the typical New Zealand commuter feels toward EVs and their economic benefits, whether they would consider the wireless dynamic charging technology, and if so, how much they would be willing to pay if the technology is in place. Respondents were collected from three organisations: New Zealand Automobile Association (AA), the NZ EV owner Facebook group, and the UoA, after attaining approval from the University of Auckland Human Participants Ethics Committee (UAHPEC). The data collection method aims to achieve a representative sample of New Zealand's population conditional on time and cost constraints. The survey is organised into five sections. The first collects information on respondents' type of personal vehicle usage and their general travel patterns. Second, respondents are asked to share their general attitudes toward pure EVs (battery electric vehicles). The following section then collects information on respondents' attitudes, knowledge, and usage of EV charging systems. This particular section divides the sample into pure EV users, and non-pure EV users dependent on how they answer an ownership/lease question in section one. Next, respondents are presented with a choice experiment, each facing eight choice questions where they choose their most preferred EV option out of two available alternatives or an opt-out alternative (your classic combustion engine vehicle). Each EV alternative is described by five attributes: purchase price, driving range, recharge time, emission reduction, and dynamic charging capability. The last two attributes are of particular interest to the research objective. In terms of levels for each attribute, the purchase price has four, driving range, recharge time, and emission reduction have three, and dynamic capability is described by two levels. The number of attributes and their associated levels was carefully chosen to gather enough information for a plausible analysis. At the same time, the complexity of the survey design is minimised given the risk of cognitive overload for the respondent and therefore precludes the quality of the data. Much of the literature has included an opt-out alternative like this survey. The reason for the inclusion of an opt-out option is that the main objective is to





understand the impact of the dynamic charging capability on the choice between EV types and whether it can impact the choice to adopt an EV.

For this choice experiment, three blocks are generated, each containing eight choice questions. Therefore, 24 choice questions make up a complete set. Before respondents were presented with the choice experiment, a 'cheap talk' script was included to increase the realism of the choice. In the final section, respondents were asked several socio-demographic questions, including, gender, household type, age, ethnicity, time spent living in New Zealand, work status, education, income, and region. The survey closes with some demographic questions. DCM techniques are applied to estimate the WTP for dynamic wireless charging was measured both directly and indirectly.

## Results

After cleaning the data, the final sample consisted of 1238 individuals, 1029 from AA members, 99 from the NZ EV owner Facebook group, and 110 from the UoA students. Because each respondent faced eight choice questions, the total number of observations would be 9,904 for the discrete choice analysis. However, due to some incomplete decisions, the total number of observations ended up being 9,887. Six main DCMs were specified, however, the final model specification is the MXL. Here the independence from the relevant alternatives assumption is relaxed, the panel structure of the data is accounted for, and it is also possible to specify whether the random parameters are correlated or not. MXLU represents the MXL model with uncorrelated random parameters, whilst MXLC represents the MXL model with correlated random parameters. The MXL models obtain higher log-likelihood values compared to all previous models. To consider whether these model specifications are better suited than the MNL model, the Wald and log-likelihood ratio tests were performed to assess the existence of random parameters. More specifically, MNL was tested against MXLU and MXLC, and in all cases, there was strong evidence against no random parameters. Regarding the WTP estimates, for MNL, since the sign of the coefficient estimate was negative, the WTP is interpreted as follows: to reduce the dynamic charging capability to essentially being incapable, the individual is willing to pay at most about \$6,900 more. On the other hand, the sign of the coefficient estimate is positive for all other specifications with MXLC being the most sensible. Therefore, the interpretation becomes that to increase the dynamic charging capability to essentially being capable, the individual is willing to pay \$6,600 more at most.

## Conclusions

This research aims to understand the perceived economic and environmental benefits DIPT can provide for EVs. Overall, the results are promising and align with the literature on the benefits that DIPT can provide. Although the familiarity with this technology is low, there exists a positive weighting in attitude toward dynamic wireless charging. Through DCM, it was observed that an EV with dynamic charging capabilities has a highly significant positive impact on EV choice. Moreover, the WTP for dynamic charging was positive. In terms of the environmental feature, the response was mixed. There was no specific attitude that dominated. Additionally, the emission reduction and the environmental attribute in the discrete choice analysis had a negative impact on vehicle choice. Future research should explore extensions from probabilistic utility functions to linear utility by using a more complicated survey design.

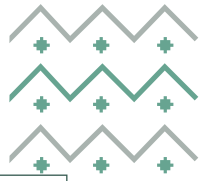
## Acknowledgement

This work was financially supported by the Ministry of Business, Innovation and Employment (MBIE) Endeavour Fund 2017 ((Research Project UOAX1711)

## References

- Poland, O. (2021). Charging into the future: infrastructure vital to electric vehicles taking off. The University of Auckland. Retrieved from: <https://www.auckland.ac.nz/en/news/2021/11/03/ingenio-EVs-charging-into-the-future.html>
- Nagendra, G., Chen, L., Covic, G. & Boys, J.T. (2014). Detection of EVs on IPT highways. *IEEE Journal of Emerging and Selected Topics in Power Electronics*, 2(3), 584-597. <https://doi.org/10.1109/jestpe.2014.2308307>
- Sheng, M., Sreenivasan, A. V., Sharp, B., Wilson, D., & Ranjitkar, P. (2020). Economic analysis of dynamic inductive power transfer roadway charging system under public-private partnership - Evidence from New Zealand. *Technological Forecasting and Social Change*, 154, 119958. <https://doi.org/10.1016/j.techfore.2020.119958>
- Sun, L., Ma, D., & Tang, H. (2018). A review of recent trends in wireless power transfer technology and its applications in electric vehicle wireless charging. *Renewable and Sustainable Energy Reviews*, 91, 490-503. <https://doi.org/10.1016/j.rser.2018.04.016>





## Investigating Mass Transit Effects on Energy Demand & Emissions in Kuwait

[Norah AlSafi, Kuwait Institute for Scientific Research, +965 24989228, nsafi@kisir.edu.kw]  
[Rawan AlKandari, Kuwait Institute for Scientific Research, +965 24956581, rikandari@kisir.edu.kw]  
[Yousef M. Al-Abdullah, Kuwait Institute for Scientific Research, +965 24989719, ymabdullah@kisir.edu.kw]  
[Yousef M. Al-Abdullah, Kuwait Institute for Scientific Research, +965 24989719, yabdullah@kisir.edu.kw]  
[ Sreekanth K. J., Kuwait Institute for Scientific Research, +965 24956624, sreekanthkj@kisir.edu.kw]  
[ Fotouh Al-Ragom, Kuwait Institute for Scientific Research, +965 24956727, fragom@kisir.edu.kw]

### Overview

The transportation sector of Kuwait, which at times is the largest consumer of energy, would benefit from adopting more efficient modes of transport. While some of this consumption can be attributed to generous subsidies provided by the Kuwaiti government, in reality, it is also due to a lack of public transportation options. In the past, Kuwait has stated its intent to develop a Metro system but has yet to do so.

### Methods

This investigation aimed to model Kuwait's transportation sector to determine the extent of energy that could be conserved by developing a metro system. Energy demand data was paired with vehicle usage to develop a model for the transportation sector. This model was used to project energy demand for the transportation sector up to 2040 first in a business-as-usual (BAU) case.

### Results

The study identified that by 2040, the metro ridership could reduce 60% of the road vehicles and 12 million tonnes of CO<sub>2</sub> for Kuwait. Moreover, the energy demand for the metro would require 1650 GWh of electricity in 2025, which will go up to 7320 GWh by 2040.

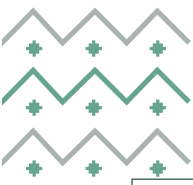
### Conclusions

This model was used to project energy demand for the transportation sector up to 2040 first in a business-as-usual (BAU) case. Using the developed model, a Metro system was simulated to demonstrate how energy demand and carbon emission could be reduced in the transportation sector by comparing the BAU case and the Metro case.

### References

1. International Energy Agency, "Kuwait," 2018. [Online]. Available: <https://www.iea.org/countries/kuwait>.
2. Kuwait Authority for Partnership Projects, "Kuwait Metropolitan Rapid Transit System (KMRT)," 2018. [Online]. Available: [http://www.kapp.gov.kw/en/Kuwait-Metropolitan-Rapid-Transit-System-\(KMRT\)](http://www.kapp.gov.kw/en/Kuwait-Metropolitan-Rapid-Transit-System-(KMRT)).
3. Central Statistical Bureau Kuwait, "Annual Statistical Abstract." [Online]. Available: [https://www.csb.gov.kw/Pages/Statistics\\_en?ID=18&ParentCatID=2](https://www.csb.gov.kw/Pages/Statistics_en?ID=18&ParentCatID=2).
4. Ferrocarrils de la Generalitat Valenciana, "MEMORIA DE SOSTENIBILIDAD," 2019. [Online]. Available: <https://www.fgv.es/la-empresa/memorias-de-gestion/?lang=en>.
5. United Arab Emirates Ministry of Energy, "UAE State of Energy Report," 2015. [Online]. Available: <https://dcce.ae/publications/uae-state-of-energy-report-2015/>.





## ***ELECTRIC VEHICLES AND ELECTRICITY CONSUMPTION: HONEY, DID I PLUG IN THE CAR?***

Jacobus Nel, University of Pretoria, +27 72 915 6721, neljaco380@gmail.com  
Roula Inglesi-Lotz, University of Pretoria, +27 12 420 4504, roula.inglesi-lotz@up.ac.za

### **Overview**

We analyse the effect of electric vehicle (EV) adoption on electricity consumption for a sample of 29 European countries. We employ a difference-in-difference approach to determine the impact of low adoption rates against high adoption rates on electricity consumption. Detecting statistically significant relationships while the market is still in its infancy, we can conclude that the effect will be much more significant once EV sales rival those of internal combustion engine vehicles (ICEVs).

The literature on EVs and electricity consumption is divided into two groups; firstly, the studies forecasting electricity demand increases from simulations and models (ex-ante). Secondly, some studies look at the load-shifting potential of EVs (using EVs as moving storage devices to smooth peak electricity demand). To our knowledge, no study has investigated this issue ex-post. Perujo and Ciuffo (2010) and Dhar et al. (2017) are two studies that form part of the first group of studies. Both these studies outline that there will be some increase in electricity consumption, while Perujo and Ciuffo (2010) state that this is insignificant; however, their study was conducted in 2010, well before the legislation passed to ban the sale of ICEVs from 2030.

### **Methodology**

We use a difference-in-difference model to analyse the data, with the treatment group being countries with EV sales above a threshold for that particular year. In contrast, the control group are the countries below this threshold for a particular year. EV sales data in all countries start in 2008, as a result, 2002-2007 is in the control group for all countries and acts as the pre-treatment period. The effective sample period is 2002-2017. We account for both country and time-fixed effects and a lagged dependent variable to avoid misspecification due to omitted variables.

$$Elect_{i,t} = \alpha + \beta_1 Elect_{i,t-1} + \beta_2 d_{i,t} + \beta_3 EV_{i,t} + \beta_4 d_{i,t} \times EV_{i,t} + \beta_5 p_{i,t} + \mu_i + \mu_t + \epsilon_{i,t}$$

Where  $Elect_{i,t}$  is the log of electricity consumption growth of country  $i$  in period  $t$ ,  $EV_{i,t}$  is EV sales growth (as the measure for EV adoption rate),  $d_{i,t}$  is the indicator variable for when the value of EV sales is high for a particular observation, and  $p_{i,t}$  is electricity price growth (log returns). Note that we model the effect of EV sales on electricity consumption contemporaneously, as the lagged dependent variable already accounts for the previous year's sales. The difference in difference estimate  $\beta_4$  then gives the effect of high EV sales on electricity consumption and is our main coefficient of interest. We also use the year Tesla superchargers become available in a country as a proxy for when Tesla officially enters a market, as a shock. Given that our identification strategies cannot be argued to be exogenous, our results are non-causal. However, they still yield essential results for policymakers.

### **Results**

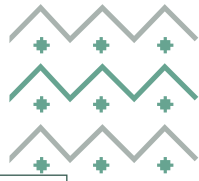
We analyse the relationship between EV sales growth and sectoral and total electricity consumption growth. We find no statistically significant evidence of a relationship between the two variables for households. Given that this result might be due to the owners not charging their vehicles at home, we also consider electricity consumption for the transport sector. Here we find a statistically significant, negative relationship between the variables, or that lower EV growth rates are associated with higher electricity consumption growth rates. This is concerning as it could indicate that individuals are substituting away from public transport in favour of private transport. The relationship between total electricity consumption growth and EV sales growth has a similar trend as the transport sector. However, these results are not robust once we account for electricity price and population size. The results with Tesla superchargers as the shock show the same pattern as that of high and low EV adoption, indicating that the results are robust against a different identification strategy.

### **Conclusion**

Given the current energy crisis mainly driven by the economic sanctions imposed by the West, we investigate the effect of EV adoption on electricity consumption and find a statistically significant relationship for total electricity







consumption and the transport sector's electricity consumption. Our results indicate that even now, with EVs only accounting for a country maximum of 0.97% of new vehicle sales in the EU in 2019, there is a statistically significant relationship between EV adoption and electricity consumption. This makes it important for policymakers and strategic decision-makers to also model EV adoption and its effect on electricity consumption to avoid future electricity supply deficits. We also find evidence that consumers are substituting away from public transportation, which could have far-reaching consequences, however, this needs to be investigated from a causal point of view to confirm this deduction and to ensure that policies are put in place to prevent this.

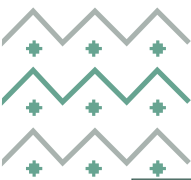
Being the first to investigate the relationship in the ex-post fashion, our study lays the foundation for academics to improve upon our methodology to deduce a causal relationship.

### References

Perujo, A., and Ciuffo, B. (2010). The introduction of electric vehicles in the private fleet: Potential impact on the electric supply system and on the environment. A case study for the Province of Milan, Italy. *Energy Policy*, 38(8), 4549-4561.

Dhar, S., Pathak, M., and Shukla, P. R. (2017). Electric vehicles and India's low carbon passenger transport: a long-term co-benefits assessment. *Journal of Cleaner Production*, 146, 139-148.





## ***EVALUATION OF THE IMPACT OF PUBLIC POLICY MEASURES ON CALIFORNIA'S FUEL CELL ELECTRIC VEHICLE MARKET DEVELOPMENT.***

Pawel Brusilo, Fulbright Visiting Graduate Student, School of Global Policy and Strategy, University of California San Diego

### **Overview**

Governments, states, and regional authorities recognize the importance of supporting the decarbonization of the transportation sector to mitigate climate change. This process can be empowered by the higher utilization of so-called *renewable* (or *green*) hydrogen (hydrogen produced with the use of electricity generated from renewable sources) [1,2]. Transitioning to higher exploitation of *green* hydrogen in the transportation sector requires changes in the public policies and strategies enacted by regional and central/federal authorities [3]. Simultaneously, the need to decarbonize the transportation sector resulted in the rapid development of the automotive industry in the area of zero- or low-emission vehicles, demonstrating a wide range of constructions, including Plug-in Hybrid Electric Vehicles (PHEVs), Battery Electric Vehicles (BEVs), and Fuel Cell Electric Vehicles (FCEVs). Since each of these constructions differs significantly and represents competitive markets, it is crucial to consider each type of vehicle individually. Undoubtedly, both PHEVs and BEVs dominate the global market of electric cars [4], so I decided to focus on FCEVs, which offer worth considering potential for transportation sector decarbonization. Indeed, individual countries and regions have applied diverse public policy incentives and introduced more or less effective strategies to promote FCEVs [5]. In the last decade, California has been presenting a gradually growing market potential for FCEVs, including light-duty passenger vehicles, buses, as well as medium- and heavy-duty vehicles used, for instance, in the freight movement in Los Angeles. This process was accompanied by developing publicly available hydrogen refueling infrastructure and increasing *green* hydrogen production, transport, and storage. In this context, the identified research problem can be formulated as a question – **How did the state policy instruments impact the fuel cell electric vehicle market development in California from 2012 to 2022?**

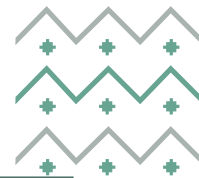
### **Literature review**

Electrification of the transportation sector is a significant action in making economy-wide decarbonization possible in California by 2030 and beyond. Research shows that the development of reliable hydrogen fueling stations will be required for the successful commercialization of fuel cell vehicles in this state [6]. The growth of the FCEV market and increasing demand for *green* hydrogen observed nowadays can be filled through commercial electrolysis using excess renewable energy [7]. However, despite the growing popularity of FCEVs in different ZEV market segments, the observed growth is still far lower than expected or predicted (considering the implemented policies and the adopted objectives) due to the significant institutional, technological, as well as demand- and supply-side market barriers [8]. The enacted policies and introduced instruments aim to overcome those barriers and accelerate the decarbonization of the transportation sector shortly. Moreover, recent studies show that the potential of hydrogen and fuel cell technologies applied in vehicles for medium- and heavy-duty sectors in California is substantial [9,10]. A comprehensive evaluation of California's public policy focused on the decarbonization of the transportation sector by promoting hydrogen and fuel cell technologies has not been made yet by applying a qualitative method with individual highly structured interviews. While a case study focused on the barriers to the FCEVs diffusion in California was already done in the past [8], my case study will cover a more extended period and scope (considering the most up-to-date data) and will be specifically focused on evaluating individual policy instruments. In undertaking this, I am focused on the effectiveness of selected public policy instruments (introduced on the state level) in deploying FCEVs in California in the last decade.

### **Methods**

I analyze and critically review the available scientific literature to systematize the state-of-the-art studies about public policy instruments used to shape California's fuel cell electric vehicle market development in the last decade. To extend the studies, I analyze the recent secondary data (through desk research), especially statistics, reports, and market publications related to the research problem. The identified key FCEV market indicators allow me to present an overview of the changes from 2012 to 2022. In addition, the comparative analysis of the public policy statements, bills, and directives on the state level allowed me to study the adopted assumptions deeply and review the implemented instruments. Last but not least, I conduct individual highly structured interviews with policymakers, researchers, and representatives of the companies and organizations that are FCEV market stakeholders, such as firms related to sustainable and low-carbon production of hydrogen as a fuel, operators of the hydrogen refueling infrastructure, supply-side market actors, and demand-side market actors. The interviews are transcribed and evaluated using the NVivo software to generate results.





## Results

The research results allow the evaluation of public policy instruments implemented in California from 2012 to 2022. The fundamentally effective instruments were those implemented on the state level. I identified four strategic objectives and matching policy instruments which are as follows: **(1) sustainable and low-cost production of hydrogen** (most effective policy instruments were: *Hydrogen Fuel Specifications and the 33% Green Hydrogen Requirement* as regulations and standards; *Low Carbon Fuel Standard* as tradeable permits), **(2) developing accessible and reliable refuelling infrastructure** (most effective policy instruments were: *AFV and Fuelling Infrastructure Grants* as subsidies; *Station Building Standards and Safety Codes* as regulations and standards; and *ZEV Infrastructure Support, Hydrogen Fuelling Station Evaluation* as the information policies), **(3) growth of market supply for FCEV** (most effective policy instruments were: *Light-, Medium-, and Heavy-Duty ZEV Requirements* as regulations and standards, and *ZEV Production Requirements* as tradeable credits), and last but not least objective **(4) growth of market demand for FCEV** (most effective policy instruments were: *Advanced Transportation Tax Exclusion, Zero Emission Transit Bus Tax Exemption, and ZEV Fee* as tax incentives, *Purchase requirements for Zero-Emission Transit Bus, Airport Shuttle, and Public Fleet Vehicles* as regulations and standards, *Bus Replacement Grants, LD-ZEV Rebates, HVIP Vouchers, and Emissions Reductions Grants* as subsidies, and *High Occupancy Vehicle and High Occupancy Toll Lane Exemption* as information policies). The strength of impact and effectiveness of these individual policy instruments were also evaluated with the quantitative approach during the interviews by assigning the weights of impact to present the overall road map for FCEV market growth in these four critical strategic development areas. The research also discusses and demonstrates the essential role of demonstration projects, such as the example of the Port of Los Angeles, where heavy-duty FCEVs are operating. The research results contribute to a better understanding of the applied public policy instruments' effectiveness in deploying hydrogen and fuel cell technologies in California's transportation sector.

## Conclusions

The substantial quantitative and qualitative changes in California's fuel cell electric vehicle market were mainly policy-driven in the last decade. It was possible thanks to the implementation of effective public policy instruments such as subsidies, fiscal allocations, and institutional support in the field of R&D activities as well as infrastructural development initiatives. These actions blazed the trail for the FCEVs in California's transportation sector, which is responsible for nearly two-thirds of this state's total annual CO<sub>2</sub> emissions. These incentives have resulted in an increasing number of hydrogen-powered cars operating in California and the development of a renewable hydrogen-generating infrastructure, making economy-wide decarbonization possible in this state by 2030 and beyond. However, the decarbonization of the transportation sector with the use of FCEVs presents a challenge for some U.S. states and other countries and regions worldwide. Therefore, it was crucial to determine which public policy instruments and projects successfully promoted the deployment of FCEVs in California. The intent of doing so was to serve as evidence-based examples for less-prosperous regions and states. It will be a great honor to present these research results and confront them with the opinion of experts at the 44<sup>th</sup> IAEE International Conference in Riyadh.

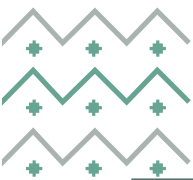
## IAEE Codes:

10.6. Transportation – Policy Issues,

10.3. Transportation - Electric vehicles & systems.

## References

- [1] Hydrogen Council (2017). How hydrogen empowers the energy transition. Retrieved from: <https://hydrogencouncil.com/wp-content/uploads/2017/06/Hydrogen-Council-Vision-Document.pdf>
- [2] International Renewable Energy Agency (2020). *Green hydrogen: A guide to policymaking*. IRENA: Abu Dhabi.
- [3] Victor, D.G., Geels, F.W. & Sharpe, S. (2019). *Accelerating the Low Carbon Transition: The Case for Stronger, More Targeted and Coordinated International Action*. Brookings Ltd.: Washington DC.
- [4] International Energy Agency. (2019). *Global EV Outlook 2019*. IEA: Paris.
- [5] Bose-Styczynski, A., & Hughes, L. (2019). Public policy strategies for next-generation vehicle technologies: An overview of leading markets. *Environmental Innovation and Societal Transitions* 31, pp. 262-272.
- [6] Brown, T., Shane S.-R., & Samuelsen G. S. (2012). Quantitative analysis of a successful public hydrogen station, *International Journal of Hydrogen Energy* 37 (17), pp. 12731-12740.
- [7] Schoenung, S.M., & Keller, J.O. (2017). Commercial potential for renewable hydrogen in California, *International Journal of Hydrogen Energy* 42 (19), pp. 13321-13328.
- [8] Trencher, G. (2020). Strategies to accelerate the production and diffusion of fuel cell electric vehicles: Experiences from California. *Energy Reports* 6, pp. 2503-2519.
- [9] Forrest, K., MacKinnon, M., Tarroja, B., & Samuelsen, S. (2020). Estimating the technical feasibility of fuel cell and battery electric vehicles for the medium- and heavy-duty sectors in California. *Applied Energy* 276, 115439.
- [10] Turoń, K. (2020). Hydrogen-powered vehicles in urban transport systems – current state and development. *Transportation Research Procedia* 45, pp. 835-841.



## ***ANALYSING THE IMPACT OF ONLINE FREIGHT PLATFORM USING DATA FROM CHINESE CITIES***

Xun Xu, KAPSARC, +966 0593562147, xun.xu@kapsarc.org  
Tianduo Peng, Institute of Climate Change and Sustainable Development, Tsinghua University, ptd@mail.tsinghua.edu.cn

### **Overview**

Driven by rapid economic development, population growth, urbanization and industrialization, road freight transportation have been one of the largest contributors to the surging oil demand and carbon emission growth globally, and especially in developing countries in the last few decades. However, in the context of Paris Agreement, as all countries need to take immediate actions to mitigate their carbon emissions, road freight transportation become one of the hardest sectors to decarbonize. This is in part due to the lack of readily available alternative low-carbon fuel technologies (e.g. battery, hydrogen) to replace existing internal combustion engine (ICE) vehicles. Another important factor is the low operational efficiencies of the trucking sector, especially in developing countries.

The recent advances in information and communication technologies has brought about a valuable opportunity to reduce market inefficiencies. The wide availability and affordability of smart phones and mobile applications have enabled the establishment of digital platforms to effectively match shippers with trucks and carriers, using a business model that is very similar to Uber. By significantly reducing the freight matching cost and the possibility of empty backhauls, the Uberization of road freight may have great potential in improving overall performance of the road logistics system. In view of this important new trend, this research intends to evaluate the impact of this technological disruption on the energy performance of the trucking sector. Specifically, recent data from over 300 cities in China is utilized for investigation.

### **Methods**

The data used in this research are sourced from China's trucking industry. Trip information from 2000 active trucks are collected for the period of October - November 2018, containing over 50000 consecutive road freight trips. Detailed information includes truck locations and trip characteristics, such as cargo weight, origin and destination locations of the trips. Other available information include truck and commodity attributes for the covered trips, such as vehicle type, vehicle length, carrying capacity, curb weight and cargo commodity type, as well as fuel type.

The share of empty running is defined and calculated in this study. Data on locations and trips are first matched to calculate the share of empty miles for all recorded trips. The produced results are then further used for an in-depth investigation to evaluate the impacts of numerous trip, vehicle and geographic factors on the trucks' empty running behavior.

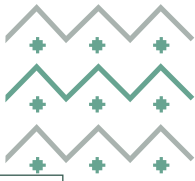
### **Results**

This section presents the estimated share of empty running for the entire sample, as well as results for different subsamples using several ways of classification. Aggregate share of empty running is defined as the ratio of total empty running distance against total trip distance at the sample/subsample level.

Next, distribution of share of empty running is compared against categorization of commodities, vehicles, trip distances, vehicle carrying capacity, and geographic origins, respectively. The results suggest that commodity types, vehicle types, and trip distances have clear impacts on empty running by trucks, whereas vehicle carrying capacity and geographic origins of the recorded trips do not betray a strong effect.

Overall, Uberization seem to have indeed generated an important impact on the operational efficiency of the road freight system and energy performance of individual truckers, by substantially facilitating the dissemination of freight information and reducing wasted truck miles. The effects seem to be pervasive and significant across all trip characteristics, including commodity types, vehicle types, vehicle carrying capacity, trip distances, and geographic locations. This implies the low effectiveness of the freight matching process in China's conventional trucking sector, and the urge to utilize the latest technologies to improve efficiency.





### Conclusions

The rapid development of the information and communication technologies in the last decade have “Uberized” a number of industries and is now starting to transform the freight trucking sector. By overcoming market inefficiencies and creating economy of scale, the digitalization of the road freight system could potentially greatly improve its operational efficiencies and thereby boosting its energy performance. Along these lines, this research utilizes recent trucking data sourced from China’s road freight sector to provide a quantitative evaluation of the Uberization’s impact on one of the key energy efficiency indicators of the trucking industry. The results suggest that the online freight platform does bring about a significant reduction in the overall percentage of empty running for the analyzed sample.

### References

IEA. 2017. *The Future of Trucks*, OECD/IEA, Paris







## Unveiling the factors influencing energy consumption in the aviation Sector of Saudi Arabia (2010-2019)

Andres Felipe Guzman

Abdulrahman Alwosheel

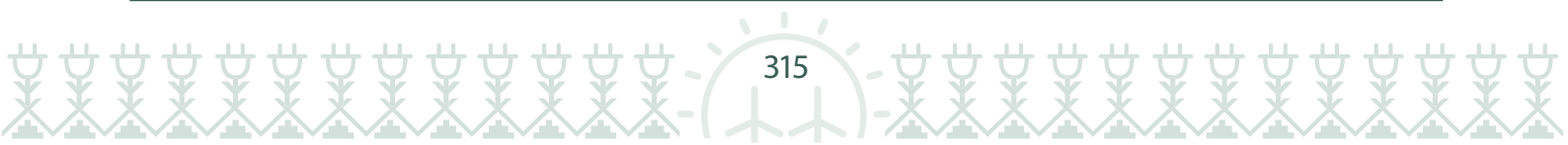
### Abstract

Nowadays, energy demand is a critical worldwide issue due to the impact that the use of fossil-based fuels could have on climate change. In fact, transportation as an end-use sector has a long tradition of consuming significant amounts of fossil-based fuels compared to residential, industrial, and commercial sectors. The road is the largest fossil-based fuel consumer worldwide, while aviation, marine bunkers, rail, and waterway transport accounted for just 20 to 22% of the total consumption in the transport sector (OPEP, 2021). However, aviation is just behind the road, historically the most significant demanding sector worldwide with 12% (OPEP). Oil demand emerging from air transportation is at the forefront of the agendas of policymakers and researchers worldwide, not only for the depletion of non-renewables but also because of related CO<sub>2</sub> emissions are rising.

As mentioned by the IEA (2021), CO<sub>2</sub> emissions emerging from the transport sector have steadily risen because of the increased demand and the limited uptake of alternative fuels. It accounted for 7.1 Gt in 2020 (37% of the total end-use sectors). Although aviation only contributes 2 to 3% of the emissions in the transport sector, the expected situation is of the utmost importance because it is one of the most challenging sectors for finding alternative energy sources.

Aviation transport in Saudi Arabia has been growing steadily during the last decade, peaking in 2019 with 103 million passengers considering domestic and international flights. The awareness of the different relations, interrelations, and interactions among the subsystems of the aviation system (i.e., aircraft, airports, and passenger load factors) during the period 2010 to 2019 are crucial to analyze the main drivers that affect energy consumption in the aviation sector of Saudi Arabia. With the benefit of hindsight, this research provides clear evidence of the role of each subsystem on energy consumption. We conclude that changes in the energy consumed in the aviation sector depend on the different subsystems that actively participate in the collective operation.

**Keywords:** aviation sector, energy demand factors, energy in transport.



**COMPARATIVE ASSESSMENT OF LCA FOR PEM FUEL CELL BUS WITH DIESEL  
AND ELECTRIC BUS: A CASE STUDY IN SAUDI ARABIA**

Chengcheng Zhao, King Abdullah University of Science and Technology, +966547329094, chengcheng.zhao@kaust.edu.sa  
Leiliang Zheng Kobayashi, King Abdullah University of Science and Technology, +966544701724, leiliang.zheng@kaust.edu.sa  
Awad Alquaity, King Fahd University of Petroleum and Minerals, +966138604976, awad.alquaity@kfupm.edu.sa  
S. Mani Sarathy, King Abdullah University of Science and Technology, +966128084626, mani.sarathy@kaust.edu.sa

**Overview**

Climate change, overpopulation, rampant pollution, and resource depletion are significant environmental challenges that the world is facing. To combat climate change, Saudi Arabia seeks to alleviate the power sector's dependence on fossil fuels and develop technologies that help global decarbonization [1]. Hydrogen proton-exchange membrane (PEM) fuel cell vehicles (FCVs) is a promising novel solution for decarbonizing the transport sector. There are three primary forms of hydrogen to power the PEM fuel cell vehicle: "grey", "blue", and "green". Grey hydrogen is produced from natural gas, blue hydrogen is also from natural gas that captures CO<sub>2</sub> emissions using carbon capture and storage (CCS), whereas green hydrogen is made from water electrolysis powered by zero/ low carbon energy sources [2]. In this study, the focus is on grey and blue hydrogen due to their cost-competitiveness and technological availability compared to green [3]. Furthermore, Saudi Arabia heavily relies on fossil fuels such as crude oil and natural gas as its main energy provider [4]. As the sixth largest natural gas reserve, with 333 trillion cubic feet (Tcf), Saudi Arabia has tremendous potential for natural gas development [5]. Therefore, grey and blue hydrogen sources are considered to be more accessible and feasible for PEM fuel cell vehicle development in Saudi Arabia. However, literature studies on the life cycle assessment (LCA) of heavy-duty vehicles are limited. There is a research gap in the environmental assessment of the application of electric and PEM fuel cell buses in Saudi Arabia, as well as the energy consumption and emissions. The complete LCA can be divided into 2 parts: fuel cycle and vehicle cycle, whereas there are just a few studies focusing on both. This study aims to bridge this gap and explored the decarbonization potential of using grey and blue hydrogen in PEM fuel cell vehicles in Saudi Arabia by comparing the life-cycle emissions of diesel engines, electric vehicles, and PEM fuel cell vehicles for heavy-duty transportation, considering both the fuel cycle and the vehicle cycle. Here, we assessed the global warming potential (GWP), abiotic depletion potential (ADP), and acidification potential (AP) of 10 PEM fuel cell (FC) buses operating in Makkah using grey and blue hydrogen produced in Saudi Arabia. For comparison, 10 battery electric buses using electricity from Saudi Arabia's grid and 10 internal combustion engine (ICE) buses running on diesel are examined across their entire life cycle. Furthermore, the refueling infrastructure requirements in Makkah and LCA for transporting hydrogen from eastern Saudi Arabia to Makkah are also defined.

**Methods**

The 'cradle-to-grave' system assessment of the environmental impacts and GHG emissions was implemented according to the LCA methodology of the International Standards Organization (ISO 14040 and 14044). The GREET (Greenhouse gases, Regulated Emissions, and Energy use in Technologies) model was developed by the U.S. Department of Energy's (DOE) Office of Energy Efficiency and Renewable Energy. It comprised two components and offered a comprehensive, lifecycle-based method to quantify the energy use and emissions resulting from the fuel cycle (calculated by GREET 1) and the vehicle cycle (calculated by GREET 2). A model was developed based on GREET 1 to quantify the energy use and emissions from feedstock extraction, feedstock production, feedstock transport, feedstock refining, fuel distribution, and fuel use by heavy-duty vehicles. The energy use and emissions required for extraction of raw material, material production, material transport, assembly of the vehicle, vehicle distribution, vehicle operation, and vehicle disposal and recycling were calculated by GREET 2. Since most vehicles in KSA were assembled overseas and delivered to Saudi Arabia, additional considerations were provided in the approach to account for the air emissions and energy use at the vehicle distribution stage.

All datasets used for the LCI compilation phase gave priority to data specific to Saudi Arabia. When these datasets were not available, other secondary data sources were used, including the GREET dataset. The data input and calculation method of GREET were not suitable for Saudi Arabia during the operation, further modifications were performed to adapt to the project's requirements.



## Results

This study explored the decarbonization potential of using grey and blue hydrogen in PEM FCVs for heavy-duty transportation in Saudi Arabia from the environmental impact point of view. Total system emissions are mainly composed of those from the vehicle production, fuel production, and vehicle usage phase. ICEV, PEM FCV, and BEV systems differ in the way how their emissions are distributed in these three stages. Based on previous research [6], we expect PEM FCVs using blue hydrogen and BEVs to deliver lower life-cycle emissions compared to ICEVs. A comparison between BEVs and PEM FCVs will be conducted. The final results are highly dependent on Saudi Arabia's specific data input and assumptions made under different scenarios.

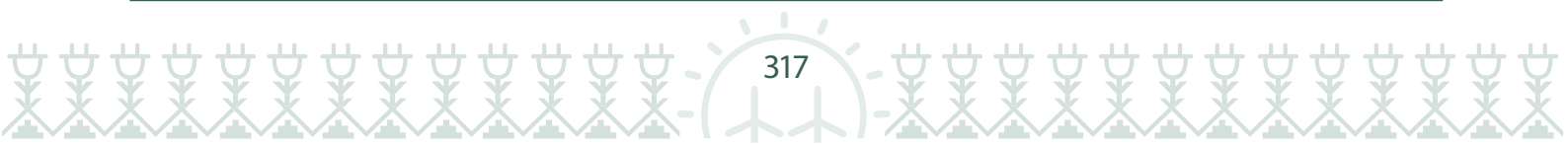
It was shown that the ICEV's emissions mainly come from the usage stage. This is the least sensitive to the area-specific variation. For BEVs, the vehicle production phase usually accounts for a large portion of the total emissions, especially when BEVs are made abroad and imported to Saudi Arabia. At the same time, the BEV system's usage phase emissions are highly dependent on the grid emissions. This is one of the key areas where the KSA-specific number plays a role, particularly when we consider the movement of power generation systems from oil to natural gas and renewables in the future. In the case of PEM FCVs, the main focus is on the fuel production phase since there is less uncertainty for emissions in the usage stage.

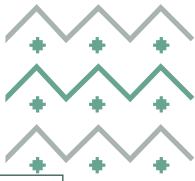
## Conclusions

A novel LCA has been performed to explore the decarbonization potential of using grey and blue hydrogen in PEM fuel cell heavy-duty vehicles in Saudi Arabia, employing both the fuel cycle and the vehicle cycle. For the hydrogen PEM FCVs, emissions from upstream fuel production and delivery (or well-to-pump) are the most critical since the emissions in the usage phase are practically zero. Hydrogen can be produced and used inside Saudi Arabia employing gas tube trailers for fuel transport. This has a potential to reduce the emissions at this stage. Because blue hydrogen has most of its production emissions captured, it delivers lower total emissions relative to grey hydrogen. However, the efficiency and energy use of carbon capture and storage system can also bring substantial uncertainty. Furthermore, improvements in battery recycling technology, the evolution of solid-state battery technology and its application in vehicles, the development of lightweighting of aluminum in vehicle production, and the utilization of pipelines to transport hydrogen all have implications for the assessment of life-cycle emissions and energy consumption. These areas of research are worth exploring in the future.

## References

1. Analytica, O., Saudi Arabia will implement a dual climate policy. Emerald Expert Briefings, 2021(oxan-db).
2. van Renssen, S., The hydrogen solution? Nature Climate Change, 2020. 10(9): p. 799-801.
3. The hydrogen trajectory. 2021; Available from: <https://home.kpmg/xx/en/home/insights/2020/11/the-hydrogen-trajectory.html>.
4. Conti, J., et al., International energy outlook 2016 with projections to 2040. 2016, USDOE Energy Information Administration (EIA), Washington, DC (United States ....
5. Administration, U.S.E.I., Country Analysis Executive Summary: Saudi Arabia. 2021: EIA.
6. Yang, Z., B. Wang, and K.J.E. Jiao, Life cycle assessment of fuel cell, electric and internal combustion engine vehicles under different fuel scenarios and driving mileages in China. 2020. 198: p. 117365.





## *Modelling the Determinants of Electrical Vehicles Adoption: A Saudi Perspective*

Ryan Alyamani, KAPSARC, +966112903158, ryan.yamani@kapsarc.org  
Dimitrios Pappelis, UCL, +447308158183, d.pappelis.19@ucl.ac.uk  
Maria Kamargianni, UCL, +4420767955942, m.kamargianni@ucl.ac.uk

### Overview

Global transport is one of the most significant contributors to fossil fuel consumption, local air pollution and greenhouse gas emissions. In 2019, it was responsible for almost a quarter of all direct carbon emissions globally, around three-quarters of which were due to road vehicles (IEA, 2020). A potential solution is offered by electric vehicles (EVs), which are four times more efficient than conventional internal combustion engine vehicles and provide an opportunity to significantly reduce national emissions when combined with low-carbon intensity energy systems (IEA, 2021). The EV market is expected to continue growing significantly as EV deployment is increasingly of interest in many countries as they strengthen their environmental commitments and efforts.

The Kingdom of Saudi Arabia, for example, has been a leader in the international energy markets, contributing to both global and its own domestic economic growth. However, the economic growth in the country is also associated with a surge in emissions: between 1990 and 2014, its total emissions tripled to 600 CO<sub>2</sub> million tons (Wogan et al., 2019). In 2016, however, the country embarked on a societal and economic makeover through its Vision 2030, placing sustainability at the core of its future development. In the days leading up to COP27 in 2021, Saudi Arabia amplified its Paris Agreement pledge, committing to carbon neutrality by 2060. Aware of the magnitude of this commitment for the world's largest oil exporter, the government has launched a range of further environmental-friendly initiatives. One of those initiatives is a target of 30% EV penetration in Riyadh by 2030. Thus, it is essential to build a comprehensive understanding of potential demand and response to different adoption-incentivising policies given that in the early stages of EV adoption, in particular, adopting optimal incentivising measures reduces the burden on government (Langbroek et al., 2016). However, to the best of our knowledge, no publicly available study investigates the demand for EVs by the population of Riyadh City. This study thus aims to fill the gap by examining consumers' acceptance of EVs in Riyadh City and the expected responses of consumers to various attributes and incentives.

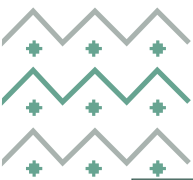
### Methods

The analysis was conducted through primary data from a stated-preference survey targeting adult residents (aged 18 and older) in Riyadh City. The sample was distributed through convenient sampling to attain a total of 703 responses from the targeted audience. Characteristic sample analysis was conducted to find that the collected sample closely follows the population shares. However, Saudis and those aged 25–34 are more highly represented than in the population. Aside from providing analysis on travelling behaviour and vehicle purchase preferences, the study utilised Biogeme python software to construct a mixed logit model, capturing the utility of EV adoption.

### Results

According to the survey, an average household (average household = 5 members, excluding domestic workers) owns 3.04 vehicles, 40% of which are described as SUV, a van or similar. Even among those who indicated no car





ownership, 97% expressed their transfer through vehicles (taxi service, car rental, or friend/relatives' cars). The survey also showed that, on average, residents of Riyadh make about four trips a day: based on respondents' approximations, 20% of all the trips take less than 15 minutes and 70% less than 30 minutes.

In total, the stated-preference experiment collected 4110 observations, where EVs were chosen 1920 times (47%) and conventional vehicles 2190 times (53%). The model shows that unlike emissions from conventional vehicles, the emission levels of electric vehicles are insignificant in determining consumers' selection. Respondents were more sensitive to changes in the monetary values of electric vehicles than conventional vehicles. Regarding any anxiety about EV ranges, the same sensitivity was found in changes in EV ranges relative to traditional vehicles. Charging infrastructure availability and non-financial incentives (i.e., access to designated parking and road lanes) positively influence the likelihood of EV adoption. Regarding the socioeconomic and travel-behaviour determinants, Saudi participants were less likely than expats to purchase EVs. Meanwhile, females and those (both genders) in their 40s showed a likelihood of purchasing an EV, which aligns with studies conducted on the region. Also, those with an average of shorter trip durations (less than 30 minutes) and those who personally know EV owners in Riyadh were more likely to adopt them.

### Conclusions

Attaining the determined target is a significant challenge that requires significant reforms to incentivise EV uptake. This is especially true since Saudis showed caution in their adoption decision-making, with high consideration to the variation in monetary incentives for EVs. Although providing economic incentives such as tax exemption will likely encourage adoption levels, there are also opportunities for policy interventions that create less of a financial burden on the government. This could be providing access to designated public parking spaces for EVs and providing EV owners access to the newly introduced bus road lanes in Riyadh City. Since being allowed to drive, an increasing number of females are acquiring vehicles in Riyadh, creating an opportunity to enhance EV adoption, given that this study shows their higher tendency relative to males. It is worth noting the study shows that almost 60% of the targeted population indicated an interest in purchasing a vehicle in the upcoming three years, where the great majority stated that a new vehicle would replace an existing vehicle. This creates a window of opportunity to implement optimal incentivising policies, as once a conventional vehicle is purchased, investment then becomes 'locked' for a period of years.

### References

IEA 2020. Tracking Transport 2020.

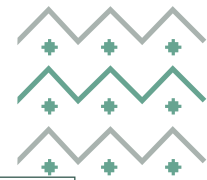
International Energy Agency 2021. Global EV Outlook 2021 – Accelerating ambitions despite the pandemic.  
Langbroek, J.H.M., Franklin, J.P. and Susilo, Y.O. 2016. The effect of policy incentives on electric vehicle adoption. *Energy Policy* 94. doi: 10.1016/j.enpol.2016.03.050

Sheldon, T.L. and Dua, R. 2019. Measuring the cost-effectiveness of electric vehicle subsidies. *Energy Economics* 84. doi: 10.1016/j.eneco.2019.104545

Wogan, D., Carey, E. and Cooke, D. 2019. Policy pathways to meet Saudi Arabia's contribution to the Paris Agreement. The King Abdullah Petroleum Studies and Research Center (KAPSARC) (February).





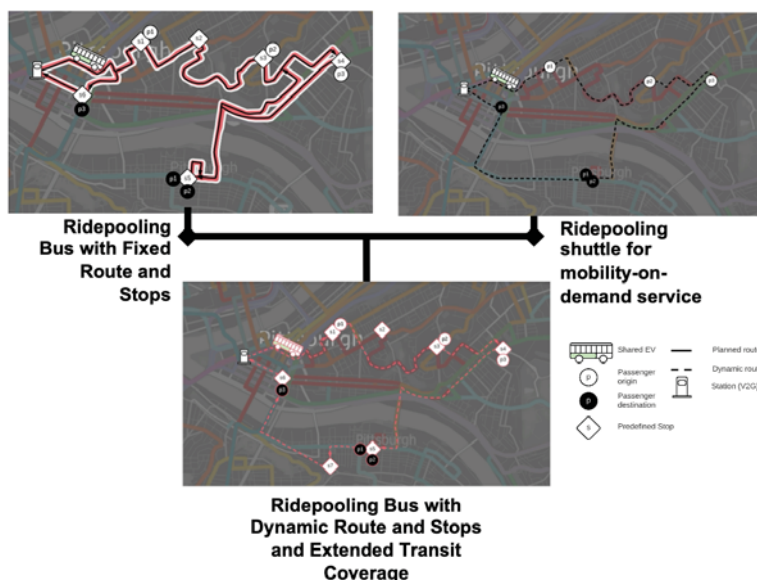


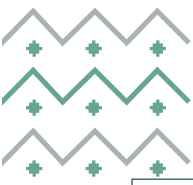
## Equitable Ridepooling with Community-Driven Stops Using a Fleet of Autonomous Electric Vehicles

Rami Ariss, Ph.D. Civil & Environmental Engineering, Carnegie Mellon University, +1 (628) 224-9177, [rariss@andrew.cmu.edu](mailto:rariss@andrew.cmu.edu)  
Jeremy Michalek, Prof. Engineering and Public Policy, Carnegie Mellon University, +1 (412) 657-9879, [jmichalek@cmu.edu](mailto:jmichalek@cmu.edu)  
Matteo Pozzi, Prof. Civil & Environmental Engineering, Carnegie Mellon University, +1 (412) 992-8460, [mppozi@andrew.cmu.edu](mailto:mppozi@andrew.cmu.edu)

### Overview

The promising developments towards full driving automation will revolutionize transportation by presenting significant opportunities in self-driving vehicles, shared mobility, and electrification. However, it is critical that social responsibility be at the heart of this transition or else comfort and convenience for the privileged will come at the expense of marginalized groups and the environment. An equitable transportation revolution must ensure fleets of autonomous vehicles are electric and shared. Modernizing public transit for a shared autonomous future necessitates fleet management controls designed for ridepooling and handling the logistical complexities of electric vehicles. We formulate and address a multi-agent control problem where a fleet of multi-passenger autonomous electric vehicles (e.g. buses or shuttles) are coordinated by a central transit agency to best serve a community of riders who choose routes based on a predetermined set of stops. This novel autonomous ridepooling framework lays between existing public transit services with fixed station stops and routes and pure mobility-on-demand services (e.g. Uber, Lyft) with dynamic and adaptive stops and routes. The transit agency is expected to act in the best interest of society, managing the autonomous electric fleet to maximize social good by accounting for externalities in equitable and sustainable transportation. Rider data privacy and sociodemographic information collected and utilized by the transit agency will be nominal and socially responsible. We develop a Multi-Agent Reinforcement Learning (MARL) simulation environment and test various heuristic and RL trained policies that can control a fleet of autonomous electric vehicles for ridepooling with stochastic requests from a community. Using domains with different graph sizes (e.g. number of geographically distributed stop locations) and request distributions (i.e. for rider requests over each route), we observe that RL methods can be used to learn useful multi-agent policies that outperform benchmark heuristics, though performance is domain-dependent. Furthermore, trained autonomous RL agents can learn and follow policies that complement existing transit in our multi-agent framework, allowing them to extend the capacity and equity of legacy transportation systems.





## Methods

We formulate a multi-agent ridepooling problem for a fleet of autonomous electric vehicles that adapt to community-driven requests to maximize social good. Vehicles serve as agents coordinated by a central agency that collects and distributes information on riders' origin-destination preferences over a set of potential stops and wait times. The formulation limits the amount of discriminatory information collected from passengers to uphold data privacy and social responsibility. Vehicle actions include driving to pick-up, pool, complete rides of multiple passengers, to stay and wait at a location, or to reach charging stations to recharge batteries. We model the system as a Markovian process whose evolution is dictated by the current state of the fleet and riders, autonomous electric vehicle and central agency decisions, and ride request and other exogenous information. The reward function incorporates ride profits, equity incentives, and time and distance-based operational and charging costs. The objective is to learn an optimal, dynamic multi-agent strategy that the central agency and individual vehicles can implement to maximize social good, including equity-based completed rides, wait times, and operational costs.

In order to model sequential decision-making under uncertainty, a Markov Decision Process (MDP) is used to frame stochastic control processes. Exact dynamic programming methods, such as value iteration and policy iteration, can be used to solve for an optimal policy that maximizes the discounted cumulative reward with guaranteed convergence based on known dynamics, known reward functions, and properties of the Bellman equations as a contraction operator. However, as the dynamics and reward functions are unknown in our ridepooling framework, these exact dynamic programming methods cannot be used. Furthermore, our state-action space is continuous and of high-dimensionality, so exact dynamic programming methods cannot be used and cannot scale. This necessitates our use of approximate dynamic programming methods, or reinforcement learning (RL) to learn policies over high-dimensional discrete and continuous state-action spaces in stochastic environments without prior knowledge of the dynamics or reward functions.

Within variations of our problem framework—incorporating passenger counts, passenger wait times, and trip or episodic time remaining—we explore different reward functions and demonstrate the ability for useful policies to be learned and outperform heuristics. As our ridepooling framework is novel, we propose reasonable heuristic policies that dictate a vehicles action for benchmarking. These heuristics include a random policy, fixed route policy (i.e. solving a eulerian circuit and cycling through stops), greedy policy (i.e. choosing the stop with the most outstanding requests), max state policy (i.e. choosing and completing a route with the most outstanding requests), and a dynamic programming lookahead policy (e.g. solving a three-step dynamic program lookahead for the current state and selecting a proxy optimal action using the learned value function).

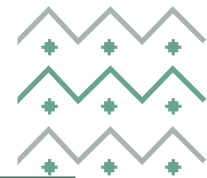
## Results

We utilize Double Deep Q-Networks (DDQN) as an RL algorithm to learn a useful neural network policy across various ridepooling domains. These domains vary by grid sizes (3-10 locations), geographic distribution of stops, request distributions (e.g. Skellam distribution for net requests; pulsed and time-cyclic requests), and reward functions (e.g. including distance-based costs; equity-scaled requests). We observe that RL outperforms most of our proposed heuristics over these domains with respect to mean episodic drop-offs to  $\pm 2$  statistically significant sample standard deviations. In terms of scalability, DDQN can learn a useful policy within reasonable computation time over these domains, while inference using a learned neural network policy is comparatively exceptionally quick and can be used for real-time execution. Multi-agency is also demonstrated where a single autonomous vehicle learns and adapts to an existing fleet of fixed route vehicles to collectively maximize the cumulative discounted reward.

## Conclusions

To empower an equitable and sustainable transportation future, novel fleet management controls are needed in transportation systems to leverage autonomous, electric vehicles. We demonstrate a novel ridepooling framework as a Markov Decision Process and develop simulation environments that utilize an efficient set of state and action spaces that capture equity-based ridepooling with multiple agents to train RL-based policies on. In this environment, domain-specific performance varies by the number of locations, geographic distribution of stops, the set of route request distributions, and structure of the reward function. Over a variety of domains, we demonstrate the ability to learn useful policies under uncertainty using DDQN that can outperform reasonable heuristic policies (i.e. random, fixed route, greedy, max state, dynamic programming lookahead). We find that over the explored domains, the larger the grid size and the more heterogeneous the route request distributions are, the more likely that RL-based methods will outperform heuristic methods with statistical significance.





## ***PRESENT AND FUTURE TREND IN SAUDI SEABORNE TRADE AND OIL DEMAND: COULD BAU SCENARIO MEET NTL'S MARITIME TARGET?***

AHM Mehbub Anwar<sup>1</sup>, +966 (0) 11 290 3187, [mehbub.anwar@kapsarc.org](mailto:mehbub.anwar@kapsarc.org)

Rubal Dua<sup>1</sup>, +966 (0) 11 290 3013, [rubal.dua@kapsarc.org](mailto:rubal.dua@kapsarc.org)

Nora Nezamuddin<sup>1</sup>, +966 (0) 11 290 3049, [nora.nezamuddin@kapsarc.org](mailto:nora.nezamuddin@kapsarc.org)

Abdulrahman Alwosheel<sup>1</sup>, +966 (0) 11 290 3163, [alwosheel.abdulrahman@kapsarc.org](mailto:alwosheel.abdulrahman@kapsarc.org)

<sup>1</sup>King Abdullah Petroleum Studies and Research Center (KAPSARC), Airport Road, Riyadh 11672, Saudi Arabia

### **Overview**

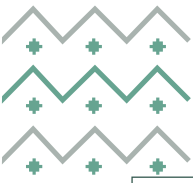
Sea transportation is the most important industry that serves world trade substantially and marks a significant amount of oil demand to perform the trade. Growing world population and its expected living standard results in shrinking of local resources and thus, increases the dependency of the world economy on international trade. This in turn, results in an increase in world seaborne trade. Recently, Saudi Arabia has established several strategic tactics such as Saudi Vision 2030 to predict the future of the country. One of the key elements in this vision is to transform Saudi Arabia into a global transport and logistics hub, with its strategic location at the epicenter of three continents. Utilization of this locational advantage is expected to cause huge trade in future, which results in additional oil demand in this sector. This advantageous location gives Saudi Arabia unmatched competitive growth in the region and allows it to become a leading regional logistics hub. To realize a growth in the economy of the country, this paper predicts the future values of total seaborne export and then potential fuel consumption in the Saudi shipping sector. Furthermore, Saudi Arabia launched the country's National Transport and Logistics Strategy (NTLS) program and as a part of this program, NTLS has set a target of reaching a capacity of more than 40 million TEU (twenty feet unit) annually (Taha, 2021). The paper observes whether Saudi Arabia can reach the target depending on various GDP growth. Finally, as future oil demand is estimated using forecasted exports, understanding the key drivers relating to Saudi exports becomes imperative. This paper also investigates the key driving factors of Saudi exports. We utilized three different determinants including supply side GDP per capita (GDPpc-SS) i.e. Saudi GDP per capita, demand side GDP per capita (GDPpc-DS), i.e. top five export country's GDP per capita and Saudi crude oil spot price (spot price) to analyze their impact on seaborne export.

### **Methods**

Time trend model with outlier and break detection approach was employed and calculated at a CAGR, called business-as-usual (BAU) scenario to forecast Saudi seaborne export up to 2040 and then, the corresponding fuel consumption in this sector is estimated using the energy intensity number. The error correction model (ECM) was applied to determine the long-run and short-run dynamics among the variables while fully modified ordinary least squares (FMOLS) cointegrating regression equation was estimated to determine the impacts of the variables on the seaborne export.

### **Results**

As of 2019, the estimated fuel consumption in the Saudi shipping sector is about 0.173 million barrels oil equivalent per day (mboe/d). Considering it as a baseline demand, oil demand is expected to grow by 0.046 mboe/d by 2040 under the business-as-usual scenario. Regarding the key drivers' impact on Saudi exports, the results indicate that GDPpc-SS and GDPpc-DS positively correlates with seaborne export whilst spot price is inversely related to seaborne export. The results further indicate that GDPpc-SS is the most prominent determinant among all and has a higher impact on seaborne export. ECM has identified a sizable speed of adjustment of 53.04% for correcting the system previous period's disequilibrium annually, meaning that almost 53% of the discrepancy between long run and short run is corrected within a year. Based on the results, this study puts forward several policy implications. Finally, assumptions of various Saudi GDP forecasts lead to understand the potentials of achieving NTLS's target.



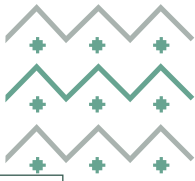
### **Conclusions**

In conclusion, exploring the presence and the direction of causal relationship between a country's trade and economy can aid in the formulation of its long-term economic policies. The outcome of this paper indicating a significant relationship between GDP and seaborne trade is very worthwhile for the government officials, decision makers, and international affairs of a nation like Saudi Arabia. Because the decisions or actions taken by them might have economic repercussions, and therefore, they should realize the relationship prior to acting.

### **References**

Taha, R. (2021). Saudi Arabia's Crown Prince launches National Transport and Logistics Strategy. Al Arabiya News: <https://english.alarabiya.net/News/gulf/2021/06/30/Saudi-Arabia-s-Crown-Prince-launches-National-Transport-and-Logistics-Strategy> accessed on December 15, 2021.





## Achieving sustainable freight movement in Saudi Arabia via transport policy

Nora N. Nezamuddin, KAPSARC, +966 (11) 290 3049, Nora.Nezamuddin@kapsarc.org

### Overview

Economic diversification is a top priority for Saudi Arabia under Saudi Vision 2030, the government's national development masterplan, which sets ambitious targets for the growth of the Kingdom's non-oil industries. This includes making the country a global player in logistics by enhancing the freight transport sector and associated value chain while confronting the related challenges posed by climate change. Transport policy measures can contribute to these objectives. Currently, the Saudi freight transport network is predominantly served by one mode, road freight. The lack of a robust multi-modal freight system undercuts Saudi Arabia's ability to meet its objectives for the sector and contributes to the levels of carbon emissions from the transport sector in the country. This study applies the KAPSARC Transport Analysis Framework to address the heterogeneity of urban, regional and inter-regional areas by analyzing socioeconomic and spatial differences to quantify the likely impacts of different types of policies on fuel consumption, carbon dioxide (CO<sub>2</sub>) emissions, and freight tonnage moved. Two scenarios are explored, the first, applying an infrastructure policy of developing a railway line which connects the west coast with the existing railway network in the center/east of the country. The second scenario explores applying regulations to reduce fuel consumption.

### Methods

The KAPSARC Transport Analysis Framework (KTAF) methodology integrates five analytic steps to run a into an online network analysis visual application. First, it combines NTL satellite images with indicators of employment and employment productivity to infer economic and human activity data, segregated for the purposes of this study by different profiles of urban centers. Second, it analyzes this data in an aggregate four-step transport demand model where generation and distribution of trips are calculated. Third, KTAF employs an approach known as ASIF (activity, modal share, energy intensity, carbon intensity of fuel), initially developed by Schipper et al. (2001), to estimate energy consumed and emissions from transport. Fourth, it applies an avoid, shift, and/or improve approach (A-S-I) approach for setting policy measures. This approach focuses on demand-side policy measures that create sustainable transport system design. It focuses on reducing the use of high-emitting transport modes, shifting toward more environmentally friendly modes and optimizing the operational and technological efficiency of transport modes (Bongardt et al. 2019). Finally, KTAF conducts an impact assessment of the environmental, economic and social outcomes of freight movement.

### Results

The findings of the study showcase the potential effectiveness of measures to increase logistics efficiency, reduce emissions of greenhouse gases and other pollutants, and diminish the consumption of fuel for freight transport activities. The results indicate that Saudi Arabia can achieve the largest reduction in CO<sub>2</sub> emissions by combining regulatory and pricing policies with an infrastructure buildout that focuses on increased accessibility to existing major logistical areas in the Kingdom. Additionally, a more robust multi-modal freight system will reduce road congestion and associated maintenance costs.

### Conclusions

Saudi Arabia's transport sector can play an important role in facilitating the country's efforts to diversify its economy. This study offers empirical insights into transport and infrastructure policies in Saudi Arabia, building on the EU Commission's urban/region profile typologies approach to quantify the impacts of transport regulations. It sheds light on how transport regulations can help rationalize fuel consumption and reduce greenhouse gas emissions and other air pollutants in the Kingdom. Utilizing the KTAF process, beginning with inferring economic and human activity data by combining NTL satellite images and economic indicators of employment and employment productivity. Next, an analysis of the data is conducted with an aggregate four-step transport demand model, after which an ASIF approach is applied to these results. Finally, an A-S-I approach is utilized to set policy measures. The analysis considers two scenarios for Saudi Arabia. Scenario 1 looks at the effects of implementing an infrastructure policy of developing the Landbridge project connecting Makkah Province to the Eastern Province







through Riyadh. Scenario 2 combines the Landbridge infrastructure development with regulations to reduce fuel consumption: diesel fuel price reform and environmental charges. The results demonstrate the considerable impact infrastructure development and transport policy measures can have on fuel consumption in freight activities in Saudi Arabia. The study showcases the potency of combining different policy approaches to increase the efficiency of freight transport activities, reduce emissions of GHG and other pollutants, and decrease fuel consumption in freight transport activities while developing critical transport infrastructure that can help the Kingdom meet its 2030 economic reform targets.

## References

Atalla, Tarek N., Anwar A. Gasim, and Lester C. Hunt. 2018. "Gasoline Demand, Pricing Policy and Social Welfare in Saudi Arabia: A Quantitative Analysis." *Energy Policy* 114(3): 123-133.

Baumgartner, J.P. 2001. "Prices and Cost in the Railway Sector." Ecole Polytechnique Federale de Lausanne.

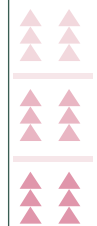
[https://www.cupt.gov.pl/images/zakladki/analiza\\_koszt%C3%B3w\\_i\\_korzysci/J\\_P\\_Baumgartner\\_Prices\\_and\\_Costs\\_in\\_the\\_Railway\\_Sector\\_Ecole\\_Polytechnique\\_Federale\\_de\\_Lausanne\\_2001.pdf](https://www.cupt.gov.pl/images/zakladki/analiza_koszt%C3%B3w_i_korzysci/J_P_Baumgartner_Prices_and_Costs_in_the_Railway_Sector_Ecole_Polytechnique_Federale_de_Lausanne_2001.pdf)

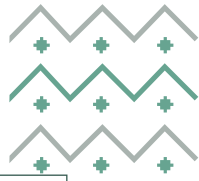
Bongardt, Daniel, Lena Stiller, Anthea Swart, Armin Wagner. 2019. "Sustainable Urban Transport: Avoid-Shift-Improve (A-S-I)". Deutsche Gesellschaft für Internationale Zusammenarbeit (GIZ) GmbH. [https://sutp.org/files/contents/documents/resources/L\\_iNUA/ASI\\_TUMI\\_SUTP\\_iNUA\\_April%202019.pdf](https://sutp.org/files/contents/documents/resources/L_iNUA/ASI_TUMI_SUTP_iNUA_April%202019.pdf)

Lopez-Ruiz, Hector.G., Christidis, Panayotis, Hande Demirel, and Mert Kompil. 2013. "Quantifying the Effects of Sustainable Urban Mobility Plans." European Commission, Joint Research Centre, Institute for Prospective and Technology Studies (IPTS).

Lopez-Ruiz, Hector G., Nora N. Nezamuddin, Reema Al Hassan, Abdel Rahman Muhsen. 2019. "Estimating Freight Transport Activity Using Nighttime Lights Satellite Data in China, India and Saudi Arabia." KAPSARC DOI:10.30573/KS--2019-MP07.

National Oceanic and Atmospheric Administration (NOAA). 2018. Version 1 VIIRS Day/Night Band Nighttime Lights. <https://ngdc.noaa.gov>.





## Assessing the development of KSA as a sustainable logistics hub – A geospatial multi-criteria analysis

[Nourah Alhosain, KAPSARC, +966550892000, Nourah.hosain@kapsarc.org]

[Lama Yaseen, KAPSARC, Lama.Yaseen@kapsarc.org]

[Nora N. Nezamuddin, KASPARC, Nora.Nezamuddin@kapsarc.org]

### Overview

Recent changes in transport policies and regulations around the world influenced by global events and commitments are reshaping internal and external freight flows. Disruptions in the global supply chain caused by the COVID-19 pandemic and exasperated by continued geopolitical situations have renewed calls for more resiliency and sustainability in the traditional production and supply chain. Additionally, an estimated 7% of global CO<sub>2</sub> emissions stem from international trade-related freight transport and logistics activities (ITF, 2016). This calls for a deeper understanding of how transport infrastructure plays a key role in supporting the reshaping of transport flows. KSA's strategic geographic location along the East-West shipping lane, where around 13% of international trade passes through the Suez Canal on KSA's Red Sea coast, puts the country in a unique position to develop its logistics infrastructure to one that will play a larger role in the global supply chain, allowing the country to inch towards its plans to become a global transport and logistics hub. Understanding the current layout of transport and logistics infrastructure in the KSA and using geospatial multi-criteria analysis to assess the effectiveness, sustainability, and resilience of the newly proposed logistics projects in KSA will shed light on how to enhance the overall transport and logistics network and if it improves the efficiency.

### Methods

This study uses a geospatial multi-criteria analysis (GIS-MCA) technique to highlight the impacts of transport policy options. MCA is a well-structured technique that establishes preferences between options by referencing a specific set of objectives. Integrating geospatial analysis with MCA is an ideal approach that combines relevant yet diverse quantitative and qualitative data into composite indicators for ranking different scenarios (González et al., 2011) and takes into account spatial dimensions and geographical data models when developing the evaluation criteria (Ryan and Nimick, 2019). In this study, the Analytic Hierarchy Process (AHP) is applied to find the relative weight and priority of each identified criteria through a preference matrix that compares all the identified criteria against one another.

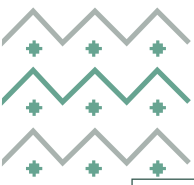
### Results

The results of the study provides a comparison between the different logistics zone projects under development in the country. It sheds light on the efficiency, sustainability, connectivity to the overall network, and resilience of the different projects planned in the KSA. Through the MCA, various factors indicative of a suitable location for logistics centers will be assessed. Suitability maps for each criterion will be combined and correlated to the findings of the AHP to arrive at an assessment of the current infrastructure of said centers and possibly highlight other locations based on the criteria defined.

### Conclusions

This study aims to understand the current layout of transport and logistics infrastructure in the KSA and assess the effectiveness, sustainability, and resilience of the newly proposed logistics projects through a geospatial multi-criteria analysis. Using GIS-MCA techniques to facilitate the analysis of multiple factors with consideration of the spatial aspect to evaluate and prioritize alternative scenarios, which allows for the understanding of how the new logistics projects will enhance the overall transport and logistics network and improve efficiency.





## References

González, A, A Gilmer, R Foley, J Sweeney and J Fry (2011). Applying geographic information systems to support strategic environmental assessment: Opportunities and limitations in the context of Irish land-use plans. *Environmental Impact Assessment Review*, 31, 368–381

Greene, Randal & Devillers, Rodolphe & Luther, Joan & Eddy, Brian. (2011). GIS-Based Multiple-Criteria Decision Analysis. *Geography Compass*. 5. 412 - 432. 10.1111/j.1749-8198.2011.00431.x.

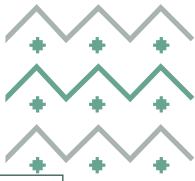
Mouter, Niek. (2021). *Chapter One – Standard Transport Appraisal Methods*. *Advances in Transport Policy and Planning*. Volume 7, pg. 1-7. < <https://doi.org/10.1016/bs.atpp.2021.02.001> >

Saaty, T. L. (1980) *The Analytic Hierarchy Process: Planning, Priority Setting, Resource Allocation*, New York: McGraw-Hill.

The Carbon Footprint of Global Trade – Tackling emission from international freight transport. (2016). International Transport Forum (ITF). < <https://www.itf-oecd.org/sites/default/files/docs/cop-pdf-06.pdf> >

Zucca, Antonella. M. A. Sharifi, A. Fabbri, (2008). *Application of Spatial Multi-Criteria Analysis to Site Selection for a Local Park: A Case Study in the Bergamo Province, Italy*. *Journal of Environmental Management*. 88(4):752-69. <DOI: 10.1016/j.jenvman.2007.04.026>





## Submission Summary

**Conference Name**

44th IAEE International Conference - 2023

**Paper ID**

388

**Paper Title**

Transport Infrastructure and Manufacturing Sector: An Energy perspective from India

**Abstract**

Objective:

The prominence of the Indian manufacturing sector has been divaricated over the years in terms of sectoral contribution to economic growth and its role as a leading sector of the economy, but it has sustained its major share in total energy consumption of the country always. Dissecting this higher energy consumption by integrating the role of transport infrastructure opens a new domain for the study where a sectoral level analysis of transport energy consumption is also possible

Methodology:

An analysis of transport energy consumption with Manufacturing sector output, the performance of transport infrastructure, and public spending on transport infrastructure in India using annual for the period 1987 to 2019. The study employed ARDL bounds test approach along with FMOLS, DOLS, and CCR methods.

Findings:

The results of ARDL bounds test followed by FMOLS, DOLS, and CCR provide evidence for the long-run and short-run relationships among study variables. The inference of the positive impact of Value Added in the Manufacturing sector on transport energy consumption validates the higher energy demand of the manufacturing sector from a mobility perspective.

**Created on**

9/19/2022, 6:07:58 PM

**Last Modified**

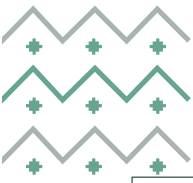
9/19/2022, 6:08:25 PM

**Authors**

MOHAMMED SHAMEEM P ( UNIVERSITY OF HYDERABAD ) < mohammedshameemp@gmail.com > ✓

**Primary Subject Area**

Transportation



## Submission Summary

**Conference Name**

44th IAEE International Conference - 2023

**Paper ID**

311

**Paper Title**

Riding the Energy Transition: Oil Beyond 2040

**Abstract**

Recent technological developments and past technology transitions suggest that the world could be on the verge of a profound shift in transportation technology. The return of the electric car and its adoption, like that of the motor vehicle in place of horses in early 20th century, could cut oil consumption substantially in the coming decades. Our analysis suggests that oil as the main fuel for transportation could have a much shorter life span left than commonly assumed. In the fast adoption scenario, oil prices could converge to the level of coal prices, about \$15 per barrel in 2015 prices by the early 2040s. In this possible future, oil could become the new coal.

**Created on**

9/9/2022, 11:05:03 PM

**Last Modified**

1/14/2023, 1:19:34 PM

**Authors**

**Reda Cherif** ( IMF ) < [acherif@imf.org](mailto:acherif@imf.org) > ✓  
**Fuad Hasanov** ( IMF ) < [fhasanov@imf.org](mailto:fhasanov@imf.org) > ✓

**Primary Subject Area**

Transportation

**Conflicts of Interest**

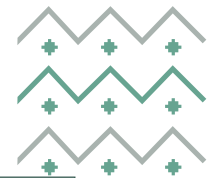
Reda Cherif - [acherif@imf.org](mailto:acherif@imf.org)  
 • a co-author



Transportation







## The state-led afforestation and socioeconomic well-being: Evidence from the Billion Trees Afforestation Project, Pakistan

### Extended Abstract

This paper aims to examine the impact of state-led afforestation activities on the socioeconomic well-being of society. The socio-economic indicators include poverty, livelihoods, health, and social cohesion. The government of Pakistan launched a reforestation project, namely the "Billion Tree Afforestation Project (BTAP)" in Khyber Pakhtunkhwa (KP) in 2014. The project aims to increase forest areas by 2% to restore impoverished forests and combat climate change (Kamal et al., 2019). The initial estimates show that the KP forest area would amount to 23.59 million hectares at the end of 2030, with an increase of 3.29% (Nazir et al., 2019).

Despite short-term contributions, rural livelihoods' sustainability remains an essential concern related to the BTAP project (Khan et al., 2019). Khan et al. (2019) argue that more efforts are needed to increase rural families' income and protect the environment. The impact of reforestation on socioeconomic well-being requires a more in-depth analysis of social and cultural norms (Le et al., 2014). These factors influence rural families' participation in afforestation activities and hence play a pivotal role in designing and improving an effective mechanism of afforestation incentives (Dinh et al., 2017; Liu et al., 2019).

We used primary data collected from 1100 households (550 beneficiaries and 550 non-beneficiaries). A multistage-sampling framework was used to collect a representative sample from two districts, Haripur and Charsadda.

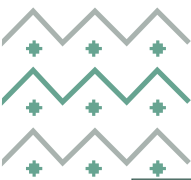
The results show that state-led afforestation activities significantly improve economic well-being, especially among the cash-cropped afforestation group. The impact varies across species planted and land utilization – agriculture vs. non-agriculture land. The project has a weak relationship with social indicators such as education and health. This implies that the economic return from afforestation is insufficient to improve social well-being.

Agriculture is an integral part of the Pakistani economy and provides direct and indirect employment to more than 70% of the workforce. Forests are essential to support rural economies and improve rural populations' well-being, mainly dedicated to agricultural subsistence activities (Dhakal et al., 2012). This study helps inform policymakers and other stakeholders about reforestation's contribution to improving families' well-being. Findings help the government to redesign the forestry policies for better coverage and long-term sustainability of forestation.

### **Billion Tree Project (BTP): An overview**

Billion Tree Afforestation Project (BTP) was designed and implemented by the KP government in response to the BONN challenge in 2011. It set the target of adding 1 billion trees in the provincial territory through regeneration (60%) and plantation (40%). It involved three phases for the completion of the project. Phase I started in November 2014 and was completed in December 2015. Phase II began in January 2016 and was completed in June 2017. The project was extended for a third phase (July 2017-June 2020) due to the availability of funds and to retain the assets (e.g., forests) generated during the project. A budget of Rs.22.5 billion was allocated for all phases in PC-1. The project's main objectives are to increase forest cover by 2%, plant one billion seedlings through regeneration and plantation by involving communities and the private sector, and provide livelihood and job opportunities to locals.

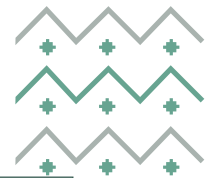




### References

- Dhakal, B., Bigsby, H., Cullen, R., 2012. Socioeconomic impacts of public forest policies on heterogeneous agricultural households. *Environ. Resour. Econ.* 53, 73–95.
- Dinh, H.H., Nguyen, T.T., Hoang, V.-N., Wilson, C., 2017. Economic incentive and factors affecting tree planting of rural households: Evidence from the Central Highlands of Vietnam. *J. For. Econ.* 29, 14–24.
- Kamal, A., Yingjie, M., Ali, A., 2019. Significance of Billion Tree Tsunami Afforestation Project and Legal Developments in Forest Sector of Pakistan. *Int. J. Law Soc.* 1, 157.
- Khan, N., Shah, S.J., Rauf, T., Zada, M., Yukun, C., Harbi, J., 2019. Socioeconomic impacts of the billion trees afforestation program in Khyber Pakhtunkhwa Province (kpk), Pakistan. *Forests* 10, 703.
- Le, H.D., Smith, C., Herbohn, J., 2014. What drives the success of reforestation projects in tropical developing countries? The case of the Philippines. *Glob. Environ. Chang.* 24, 334–348. <https://doi.org/https://doi.org/10.1016/j.gloenvcha.2013.09.010>
- Liu, Z., Zhang, T., Yu, J., Zhou, L., 2019. Determinants of rural households' afforestation program participation: Evidence from China's Ningxia and Sichuan provinces. *Glob. Ecol. Conserv.* e00533.
- Nazir, N., Farooq, A., Jan, S.A., Ahmad, A., 2019. A system dynamics model for billion trees tsunami afforestation project of Khyber Pakhtunkhwa in Pakistan: Model application to afforestation activities. *J. Mt. Sci.* 16, 2640–2653.





## Submission Summary

### Conference Name

44th IAEE International Conference - 2023

### Paper ID

36

### Paper Title

The network effects of carbon pricing

### Abstract

How would implementing a price on carbon emissions affect the structure and composition of international production networks? Which sectors or countries would bear the cost of the reconfiguration of global value chains? What will be the impact on energy production and exchange? To answer these questions, we develop a multi-sector open-economy model, and run counterfactual simulations of the macroeconomic effects of three carbon pricing policies: (i) a global uniform tax; (ii) an EU-only tax; and (iii) an EU carbon border tax.

We consider an economy producing a finite number of goods used for both intermediate and final consumption. Each good is produced by a distinct productive sector, which exists in a finite number of countries trading among themselves. Firms produce goods with a CES combination of input factors and intermediate inputs. A representative household derives utility directly from consuming a bundle of differentiated goods, themselves composed of sector-specific final goods produced in all countries. Households earn revenues from labour and taxes. Tax revenues collected on carbon emissions are evenly redistributed among domestic households in a lump-sum fashion.

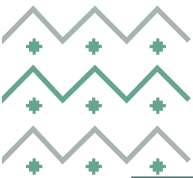
We then consider the introduction of a carbon tax on direct carbon emission intensities. The new set of intermediate good prices faced by a buyer reflects (i) the price increase resulting from the tax imposed on the direct emissions of sector, and (ii) the indirect price increases resulting from the taxes imposed on suppliers further up the value chain. The new price structure creates a process of adjustment of intermediate input exchanges, with firms recalibrating their purchase decisions towards relatively less expensive inputs. Households also react to changes in final good prices by adjusting their optimal consumption bundles. After introducing the tax, reallocating tax revenues and balancing the new inter-industry matrix, we derive and study the new equilibrium of the system.

We calibrate the model to the country- and sector-specific data provided by the World Input-Output Database (WIOD), and take elasticity values from the current literature on the topic.

Our preliminary results provide multiple insights on the network effects of carbon pricing:

- Introducing a global carbon tax, while helpful in decarbonising the global value chain, comes at a cost that is not equally distributed. High-polluting countries (e.g. China, Russia, Indonesia) lose up to 3% of their output, while others are positively affected from the tax because their relatively less polluting industries become more competitive on international markets (e.g. Sweden, Norway, Denmark).
- A global carbon tax affects the relative positioning of countries within the global value chain: countries most affected by carbon pricing (either directly or via their value chains) become less central in the network, while countries with relatively cleaner production gain access to more interconnected and central value chains (as measured by standard measures of network downstreamness and upstreamness).
- Decomposing the economic effect of carbon pricing, we also find that the impact of consumption choices is stronger than the impact of input substitution by firms. A key role is played by the change in demand driven by the increase in price of intermediate inputs, rather than the direct effect of the tax on the production.
- We are also able to compare the impacts of a global carbon tax with an EU-only tax. Global carbon emissions decrease by 4.4% in the first case, while an EU tax only brings about a 0.3% change. In terms of output costs, a global carbon tax leads to a global decrease in output of 1.6%, while an EU tax generates only a 0.5% decrease, mainly





# PROCEEDINGS OF THE 44<sup>TH</sup> IAEE INTERNATIONAL CONFERENCE

## "PATHWAYS TO A CLEAN, STABLE, AND SUSTAINABLE ENERGY FUTURE"



Conference Management Toolkit - Submission Summary

<https://cmt3.research.microsoft.com/IAEEConference2023/Submissio...>

concentrated in European countries.

- The introduction of an external carbon border adjustment policy in EU only partly affects other regions and redistributes the burden of policy-induced costs onto them.

---

**Created on**

8/20/2022, 4:28:10 PM

---

**Last Modified**

8/20/2022, 4:30:09 PM

---

**Authors**

**Emanuele Campiglio** ( University of Bologna ) < emanuele.campiglio@unibo.it > ✓

---

**Primary Subject Area**

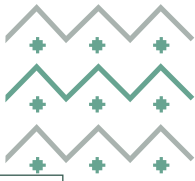
Energy and the Economy

---



Energy and the Economy





## ***OPPORTUNITY COSTS AND DISCOUNT RATES FOR PUBLIC ASSESSMENT OF OIL-RELATED PROJECTS AND POLICIES IN OIL-EXPORTING COUNTRIES***

Fatih Karanfil, KAPSARC, +966 11 290 3146, fatih.karanfil@kapsarc.org  
Axel Pierru, KAPSARC, +966 11 290 3033, axel.pierru@kapsarc.org

### **Overview**

Many oil-exporting countries are going through a transformational journey where the governments are concerned with the allocation of resources to generate new development opportunities. From a government/national perspective, the opportunity cost of oil is key for assessing projects or policies that displace oil from (or add oil to) domestic consumption. Investing in renewables, energy efficiency, industrial development projects, or implementing new regulations can impact domestic demand for oil. The public cost-benefit analysis of such projects and policy shifts requires assuming a value for a barrel of oil displaced from or added to domestic consumption. This value is the opportunity cost of domestic oil consumption. It is not necessarily the international price of oil, since it also depends on the national circumstances of the country. The public discount rate is a critical element in the assessment of the opportunity cost of oil. Because of market uncertainties, future oil price-related cash flows need to be discounted at a rate different than a *risk-free* discount rate (Pierru and Matar, 2014). The value used for the public discount rate may strongly impact the valuation of investments with a long lifetime.

Using informed estimates of the opportunity cost and public discount rates would help leverage countries' oil endowments in maximizing the welfare of their citizens. This paper proposes frameworks that can be used to estimate the opportunity cost of oil and the discount rate that account for the specificities of oil-exporting countries. Some numerical illustrations are provided for the case of Saudi Arabia.

### **Methods**

We expand our previously developed partial equilibrium model and update the results given in Karanfil and Pierru (2021). The model deals with an oil producer's welfare problem considering a major oil exporter. Constraints on oil production, the level of exports, and domestic consumption are taken into consideration as they play key roles in determining the opportunity cost of oil. The model allows us to compare different domestic oil pricing schemes and assess net welfare gains that can be generated from a reform of the domestic oil price. A special focus is given on the value to use for the public discount rate as it is a crucial parameter in the opportunity cost estimates (particularly in calculating the present value of future revenues). As an illustration, to calibrate the discount rate, we apply the extended Ramsey formula using the annual growth rates of Saudi real private and gross consumption per capita.

### **Results**

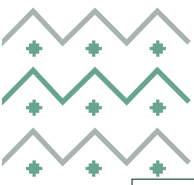
The study aims at addressing the following questions:

- What are the factors that drive the value of the opportunity cost of oil?
- Which value to use for the public discount rate?
- How to value risk diversification in an economy that depends on volatile oil revenues?

After developing a framework that enables us to study the above questions, we use it to obtain illustrative values for Saudi Arabia. The results show that the opportunity cost of oil for an oil exporter is less than the world market price. The most efficient domestic pricing policy is to set the price of oil equal to its opportunity cost. We show also that once the risk premium associated with the crude oil prices is accounted for, the public discount rate increases significantly.







## Conclusions

The paper devotes particular attention to the implications of opportunity cost and discount rate estimates for assessing projects and policies. It aims to provide frameworks to evaluate these two elements for resource allocation, project selection, and policymaking in oil-exporting countries. We argue that the oil used in public projects has to be valued at the opportunity cost and that expected oil price-related cash flows have to be discounted at a risk-adjusted discount rate, such as determined in this paper.

## References

- Karanfil, Fatih, and Axel Pierru. 2021. "The opportunity cost of domestic oil consumption for an oil exporter: Illustration for Saudi Arabia." *Energy Economics* 96, no. 105161.
- Pierru, Axel, and Walid Matar. 2014. "The Impact of Oil Price Volatility on Welfare in the Kingdom of Saudi Arabia: Implications for Public Investment Decision-making." *The Energy Journal* 35(2): 97-116.





## ***ENERGY TRANSITION AND EXPORT DIVERSIFICATION IN OIL-DEPENDENT COUNTRIES: THE ROLE OF STRUCTURAL FACTORS***

Fatih Karanfil, KAPSARC, +966 11 2903140, fatih.karanfil@kapsarc.org  
Luc Désiré Omgba, BETA-CNRS, University of Lorraine, +33 3 72747600, luc-desire.omgba@univ-lorraine.fr

### **Overview**

The contribution of carbon assets (including oil and gas) to the economic prosperity of oil-exporting countries is significant. In contrast, a critical evaluation of economies that depend on oil revenues reveals that, on average, they have not benefited much from exploiting their natural endowments. Various elements have been challenging in oil countries' management of their wealth, including the Dutch disease, the volatility of resource revenues, weak skills transfer, among others. A suggested pathway for oil countries to mitigate this new set of challenges is to diversify their economies. Diversification of oil economies should also ensure the energy security of the global economy in the path of the energy transition. For countries relying on oil-export revenues, diversification would help transform hydrocarbon revenue into other forms of assets while protecting economies from commodity price volatility.

### **Methods**

In this paper, we hypothesize that differences in structural characteristics can generate differences in the diversification paths of oil countries. This should explain why economies that exploit the same natural resource, oil, can differ significantly concerning their export baskets. Some countries having initially similar characteristics may converge towards the same level of diversification. On the other hand, they may also have diverging track records of diversification. To test this hypothesis, we first investigate whether diversification efforts that have been put by the oil-exporting countries have been converging as a whole over time. Then, we examine whether the diversification paths of individual countries create convergence clubs with different steady-state levels of diversification. Additionally, we use ordered logit models to investigate the factors behind the formation of the convergence clubs and discuss how these factors can help improve the resilience of oil-exporting countries in the future.

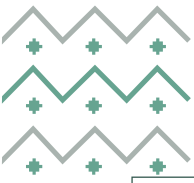
### **Results**

Despite the evidence of a correlation we show between economic resilience and diversification, countries' export diversification paths have shown little progress and have even declined in some oil countries. Our convergence analysis suggested that overall diversification efforts in oil-exporting countries have diverged but that they can be clustered into three convergence clubs with different paths and levels of diversification. We find that improvements in commercial and financial fields are associated with higher odds of being in a high diversification club. Good institutional quality and infrastructure are also found to be correlated with high diversification. Countries with a higher stock of human capital and level of R&D tend to belong to the clusters with higher diversification levels. However, economies with adverse macroeconomic conditions (e.g. inflationary environment) have higher odds of being in a low diversification club.

### **Conclusions**

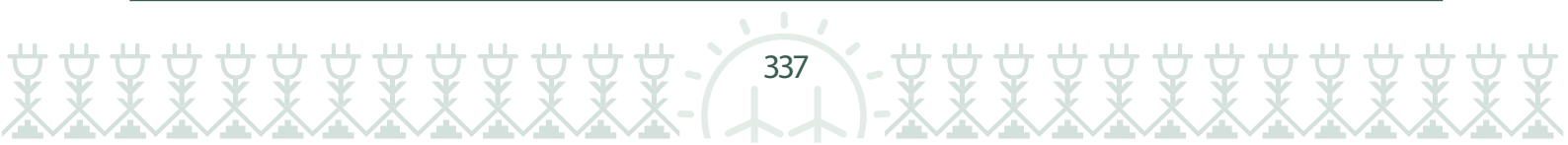
Traditional oil-exporting countries (such as Gulf Cooperation Council countries) have been implementing structural reforms and increasing efforts to diversify their economies away from exhaustible resources. Many of them have launched strategic plans or visions in this direction. For instance, Saudi Arabia's Vision 2030 aims to enhance local content, support national products and expand the industrial base in the country to promote the production of new products. Also, in line with the Vision's Financial Sector Development Program, it is aimed to strengthen financial institutions to support the growth of the private sector and stimulate investment. On the other hand, the National Transformation Program aims to improve the government's operational efficiency and enhance

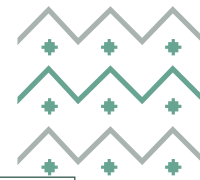




the infrastructure to improve economic enablers. As shown in this paper, all these policy measures and reforms would help increase the likelihood of countries having a more diversified and resilient economy.

### References





## SOVEREIGN WEALTH FUNDS AND NATURAL RESOURCES LINKS TO SHOCK RESPONSES: EVIDENCE FROM THE COVID-19 PANDEMIC

Stella Tsani, Department of Economics, University of Ioannina, University of Ioannina Campus, 45110, Greece. [stellatsani@uoi.gr](mailto:stellatsani@uoi.gr)  
 Wee Chian Koh, Centre for Strategic and Policy Studies, Bandar Seri Begawan, Brunei Darussalam. [wckoh@csp.org.bn](mailto:wckoh@csp.org.bn)

### Overview

The COVID-19 pandemic has put governments and the global economy under considerable stress. Governments of developed and developing countries alike have been called to take immediate action and to deploy significant public capital to address the unforeseen shock induced to the healthcare systems and to economic activity because of stringent measures, such as lockdowns, school closures and halting of non-essential services. Countries with better fiscal positions, ease of access to international capital markets or those sitting on accumulated assets, e.g., revenues from natural resource exploitation or assets accumulated in Sovereign Wealth Funds (SWFs), should be able to employ strong economic stimulus to ease the impact of the pandemic on the domestic economy. At the same time, many oil and gas exporters are faced with a twin challenge of dependence on (falling fast) oil revenues on one side and increasing pressure on the expenditure side to address the pandemic effects. Hence commodity exporters should be in a worse position to take strong policy responses against the pandemic, as compared to countries not exposed to a sharp drop on the revenue side. The economic challenges caused by the commodity price collapse are not a first-time shock experienced by resource-rich countries. Oil-producing countries, have a long experience of battling with shocks dating back to the 1970s during the first oil price shock. Over the past several decades policy makers in resource-rich countries and the academic community have investigated alternative approaches to insulating resource-dependent economies from commodity-related shocks. A prominent response to the latter has been the adoption of resource-based SWFs and fiscal rules. The group now includes not only resource-based SWFs but also pension and reserve funds. Equally impressive has been the increase in the accumulated assets managed by the SWFs worldwide amounting to a total of more than USD30 trillion in 2021 of which a large share is linked to the exploitation of natural resources, mainly hydrocarbons.

COVID-19 as a global pandemic, that has induced an external shock to commodity exporters, poses a good opportunity to examine the responsiveness of the countries to unforeseen disruptions and how these are linked to the fiscal stances of the countries. We provide empirical evidence on the COVID-19 policy responses, focusing on the role of SWFs and resource abundance. In a global sample of countries, we check whether the presence of SWFs is associated with larger responses to the COVID-19 pandemic. We complement the ongoing research in the field by paying a closer attention to countries rich in natural resources and to the role of SWFs as explicit economic tools. We find that fiscal stimulus is larger in developed, high-income and better credit rating countries. We also find that countries with higher public debt record larger fiscal stimulus against the COVID-19 pandemic. Our findings on natural resources show that there is a negative relationship between natural resources and fiscal responses to the COVID-19 pandemic with a direct impact on the fiscal balance. Resource-based SWFs are associated with smaller fiscal response while for pension and holdings SWFs, the fiscal response is significantly larger. Our results suggest that resource-based (mainly oil) SWFs did not mount a larger response. The findings remain important for their policy implications suggesting a fresh look at the role or resource riches as well as at the targets that SWFs serve.

### Methods

To address the research questions in our work we undertake a two step approach. First we discuss SWF investment allocation and actions in 2020-2021 as a response to the COVID-19 pandemic. Second we provide empirical evidence on the links between natural resources, SWFs, and policy responses to the COVID-19 pandemic. The model employed is given by:

$$S_i = a_0 + a_1 SWF_i + a_2 X_i^j + \varepsilon_i$$

where  $S_i$  is the policy response (fiscal stimulus or interest rate cut) of country  $i$ ,  $SWF_i$  is SWF-related variable,  $X_i^j$  is a vector of  $j$  control variables, and  $\varepsilon_i$  is the error term. We consider the role of income and economic, development, fatality and early stringency, population density, access to borrowing, the fiscal positioning of the countries and resource availability. For our econometric investigation we construct a novel dataset which includes economic responses to COVID-19 (fiscal and non-fiscal), infection, fatality, early stringency measures, population, government debt, fiscal balance, sovereign risk rating, resource abundance and fiscal tools (SWFs, fiscal rules). The



sample comprises of 217 countries. The coverage of the policy responses to COVID-19 spans over the period 2019-2020. We use two different measures: fiscal and non-fiscal stimulus. We construct a dataset on SWFs which allows for SWF categorisation and examination by type (resource, holdings, pension), fund size (total value in USD or % of GDP), transparency, and governance (e.g., central bank/MOF or other setting). Resource abundance is also examined (e.g., oil rents versus other resource rents), as well as country classification: resource-rich versus resource poor.

## Results

The review of SWFs investments in the pandemic shows that some of them are directly linked to the development of COVID-19 vaccines. The paper discusses Temasek Holdings injections into BioNTech and the COVID-19 vaccine development with Pfizer, the Russian Direct Investment Fund's support to the development of Sputnik V and Abu Dhabi Investment Authority's investment in Moderna. SWFs' direct responses to the COVID-19 pandemic included mainly government tapping to SWFs for spending and pandemic alleviation purposes. Examples discussed in the paper include Norway's Government Pension Fund Global, The State Oil Fund of Azerbaijan, Chile's Economic and Social Stabilization Fund and the Pension Reserve Fund, Ireland's Strategic Investment Fund, the funds of Malaysia and Turkey among other examples.

The econometric results show that fiscal stimulus is larger in high-income countries and in countries with higher debt-to-GDP ratio. Countries that imposed more stringent restrictions early in the COVID-19 outbreak record higher off-budget stimulus. With regards to resource-rich countries, fiscal response has been lower as compared to resource poor countries, especially with regards to the adoption of measures that have a direct impact on the fiscal balance. Oil exporters record lower fiscal and on budget fiscal response as compared to non-oil exporters. Regression results on resource-based SWFs show that fiscal response has been weaker in countries that operate SWFs. Findings remain similar under alternative measures of the size of the SWFs. Even within resource-rich countries, the presence of a SWF still generates a significantly weaker fiscal policy response. To capture the differentials that are related to the type of the resource-based SWF and the macro-economic policy objectives that they may serve, we experiment with the different types of resource-based SWFs (stabilisation, saving, financing) and we do not find any significant difference. Countries operating non-resource-based SWFs record stronger fiscal responses. With regards to monetary policy response, SWFs do not appear to correlate to interest rate cuts and the findings hold across the different SWF categories.

## Conclusions

The findings on resource-richness and hydrocarbon exporters provide support to the arguments that resource-rich countries, especially exporters of oil and gas, faced harsher adjustments and response choices to the COVID-19 pandemic, and this potentially limited their space for fiscal stimulus against the COVID-19 adverse effects. These may be related to the dual shock that resource/hydrocarbon exporters were faced with as opposed to countries not dependent on natural resources. Resource-rich countries, particularly oil exporters, had to address the dual shock induced by the pandemic and by the strong fall in resource export revenues. This has left resource-rich countries with little room to manoeuvre for the provision of fiscal stimulus. Results on non-resource SWFs link to the arguments that operating a SWF enables countries to have access to capital and accumulated assets that can be used in case of unforeseen shocks. This is particularly the case for countries operating pension or holding funds which manage assets to be invested in development projects or sit on accumulated cash that can offer short term liquidity and access to funding sources. The results provide a first indication on the relationship between SWFs, resource riches and policy responses to the COVID-19 pandemic. They also indicate the need to understand better the potential role of SWFs in supporting policy responses to unexpected shocks. The results also indicate the need to better understand the priorities that resource-based SWFs should serve in times of low resource prices and high uncertainty related to the climate crisis. Savings funds or oil funds not spending on the domestic economies may have been a good fit for times of high oil prices and many decades ahead of oil and gas consumption. This is an image that better illustrates developments of the past (e.g., the 2000s). In the prospect of peak oil demand theory being materialized, i.e. we should experience a peak in demand for oil anytime between 2020-2040, high oil prices should not be considered the norm in any future scenario (high prices as a result of geopolitical tensions like the recent Russia-Ukraine conflict should be considered short term deviations from the trend). In addition, climate crisis, if no timely action is taken to address it, is expected to lead to more extreme events (e.g., heatwaves, flooding, pandemics). In this vision of the future, oil exporters will need more resources to address domestic needs and unexpected socio-economic shocks rather than investment vehicles that can invest in long term assets outside the home country (as it has been the case for many oil funds to date). In this regard, oil-based SWFs may need to reconsider their mandates, and their ability to accumulate funds for internal and short time/notice use in the host countries.







## TAIL-BASED RISK NETWORK IN ENERGY SECTORS

Gazi Salah Uddin, Linköping University, +46-13282201, gazi.salah.uddin@liu.se

Axel Hedström, Linköping University, +46-15545547, axel.hedstrom@liu.se

Muhammad Yahya, Inland Norway University of Applied Sciences, +47-96951490, muhammad.yahya@inn.no

Layla Khoja, Dar Al-Hekma University, (+966) 555 590 401, lkhoja@dah.edu.sa

### Overview

Understanding and management of systemic uncertainty and contagion has become a high priority for various market participants particularly after the global financial crisis of 2008 and the recent outbreak of COVID-19. An idiosyncratic uncertainty becomes 'systemic' when there is a potential that the distress condition of one institution or a group of institutions can exert negative externality on the entire system or economy as a whole.

Despite significant literature examining the systemic risk in financial and commodity markets, the nature and extent of systemic dependence and spillover among energy companies' stock prices has received considerably less attention. Previous literature primarily revolves around estimating the dependence dynamics between energy companies' stock prices with overall financial and commodity market indexes (Kocaarslan and Soytaş, 2019). This is primarily attributed to conventional belief that energy companies do not pose a significant systemic risk to the entire energy system or for their peer companies (Zhu et al., 2020). We, however, argue that the idiosyncratic uncertainty or distress in large energy companies may significantly impact other energy companies or the sector due to counterparty relationship. Therefore, it is of significant importance to examine the systemic risk in the energy sector (Antonakakis et al., 2018). To this end, the aim of this paper is to analyse the risk spillover and network dependence across energy market participants to determine how they are affected by global economic conditions and financial uncertainty.

Our paper contributes to different strands of the existing literature. First, we extend the previous literature by evaluating firm-level network connectedness and volatility spillover among the firms operating across the four main energy market sectors (oil & gas, oil & gas related equipment and services, multiline utilities, and renewable energy). Undertaking the heterogeneity of the firms operating across the four subsectors is important as the oil & gas producing companies are only a segment of the entire energy sector.

We contend that aggregate analysis cannot capture heterogeneity in firm-level risk spillover and concentrating solely on the oil and gas producing companies provide only a partial overview of risk spillover in the aggregate energy sector. Furthermore, over the recent years, several oil & gas producers are increasingly diverting their investments to the clean energy and renewable sector (Mäkitie et al., 2019). Therefore, it is important to consider network connectedness and risk spillover dynamics by utilizing firms spanning across the four energy subsectors. Second, we utilize a novel approach to estimate network connectedness and risk spillover between the energy companies. More specifically, we combine the conditional variance-at-risk (CoVaR) approach by Adrian and Brunnermeier (2016) with the Tail-Event driven NETWORK approach by Härdle et al. (2016) to provide a comprehensive overview of the systemic risk contributors in the energy sector. Finally, we have segregated the incoming and outgoing links to identify the companies and sub-sectors with positive and negative systemic risk contribution.

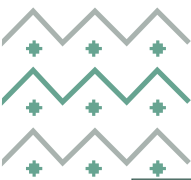
### Methods

The goal of this paper is to evaluate the network connectedness and uncertainty spillover of 100 of the worlds' leading energy companies in four different sectors: oil and gas companies (OGC), oil and gas related equipment and services (OGS), multiline utilities (MLU), and renewable energy (REC) for the period 2006 to 2020 and determine how they are affected by global economic conditions and financial uncertainty. Consequently, our models explore non-linear and semi-parametric quantile-based risk events, by looking at the network-based specifications that allow for asymmetric contemporaneous and dynamic risk interconnectedness across major energy markets.

We estimate the TENET among the underlying assets in three-steps. The first step comprises of estimation of VaR. Thus, we measure the Adrian and Brunnermeier (2016) conditional variance-at-risk (CoVaR) in a network setting. CoVaR is derived from Value-at-Risk (VaR) for a specific financial institution  $j$  conditional on another event in separate financial institutions  $i$ .  $\{X_{i,t}, X_{j,t}\} : t = 1, 2, \dots, T$ , is the returns of financial institutions  $i$  and  $j$ , respectively. Then  $\text{VaR}_{\tau,t}^i$  can be described with the quantile distribution at the  $\tau$ -th quantile of returns of  $i$ :

$$\Pr(X_{i,t} \leq \text{VaR}_{\tau,t}^i) = \tau, \quad (1)$$





and with a CoVaR of  $j$  conditional on  $X_{i,t}$  at a quantile  $\tau \in (0,1)$  is then

$$\Pr(X_{j,t} \leq \text{CoVaR}_{\tau,t}^{ji} | R_{i,t}) = \tau, \quad (2)$$

where  $R_{i,t}$  is the information set including the event  $X_{i,t} = \text{VaR}_{\tau,t}^i$  and  $M_{t-1}$  that is a vector of relevant macroeconomic variables that depict the macro state of the economy.

Whereas, in the second and third step, we estimate the network analysis and identify the key contributors and receivers of systemic risk. By utilizing the following equation, we estimate the total network connectedness among the top leading energy sectors.

$$\text{TC}_T = \sum_t^T \sum_j \hat{D}_{j \rightarrow -j,t} \quad (3)$$

## Results

Our empirical results show that there is growing interconnectedness during the extreme periods, and a network-based measure reflecting the connectivity. Furthermore, we document the asymmetric connectedness among the firms in the energy sector. Specifically, the total energy sectors, in general, are highly sensitive to the global market conditions, and the risk tends to spillover across the firms in these sectors.

In addition, we document that the firms operating in the same sub-sector are more prone to risk spillover. This is expected as the operations and services of the companies within each sub-sector are somewhat interconnected. Therefore, a key decision by a large organization may influence the operations and services of other key players within that sector.

Moreover, we find that the firms operating in the oil & gas sub-sector are more sensitive to economic downturn as compared to other sub-sectors in our sample. This may be attributed to the increased reliance of the economic activities on the oil & gas sector. Fourth, the renewable energy sector is largely unaffected by the financial crisis and only show slightly higher risk incoming and outgoing risk than in normal market conditions.

## Conclusions

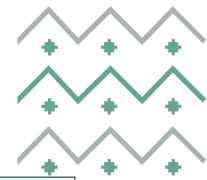
Understanding the systemic uncertainty and contagion has become the central concern for various market participants, particularly after the global financial crisis and due to the outbreak of COVID-19. The latter has especially given rise to the necessity to understand the connectedness dynamics more comprehensively among the markets. More specifically, the measures to mitigate the spread of COVID-19 globally have significantly altered the demand and supply equilibrium in the energy sector. Therefore, in this paper, we evaluate the risk spillover and network connectedness across energy market participants to determine the role of global economic conditions and financial uncertainty on the energy sector.

This study draws an important policy implication based on both the largest systemic risk receivers and the largest systemic risk emitters within the leading energy companies and sectoral groups as well. The findings of our analysis have important implications on diversification benefits and network risk management as well as policy implications for global sustainable energy markets.

## References

- Adrian, T., Brunnermeier, M.K., 2016. CoVaR. *Am. Econ. Rev.* 106, 1705–1741.
- Antonakakis, N., Cunado, J., Filis, G., Gabauer, D., Perez de Gracia, F., 2018. Oil volatility, oil and gas firms and portfolio diversification. *Energy Econ.* 70, 499–515. <https://doi.org/10.1016/j.eneco.2018.01.023>
- Bachmeier, L.J., Griffin, J.M., 2006. Testing for market integration crude oil, coal, and natural gas. *Energy J.* 27, 55–71. <https://doi.org/10.5547/ISSN0195-6574-EJ-Vol27-No2-4>
- Härdle, W.K., Wang, W., Yu, L., 2016. TENET: Tail-Event driven NETWORK risk. *J. Econom.* 192, 499–513. <https://doi.org/10.1016/j.jeconom.2016.02.013>
- Kocaarslan, B., Soytaş, U., 2019. Asymmetric pass-through between oil prices and the stock prices of clean energy firms: New evidence from a nonlinear analysis. *Energy Reports* 5, 117–125. <https://doi.org/10.1016/j.egy.2019.01.002>
- Mäkitie, T., Normann, H.E., Thune, T.M., Sraml Gonzalez, J., 2019. The green flings: Norwegian oil and gas industry's engagement in offshore wind power. *Energy Policy* 127, 269–279. <https://doi.org/10.1016/j.enpol.2018.12.015>
- Zhu, B., Lin, R., Liu, J., 2020. Magnitude and persistence of extreme risk spillovers in the global energy market: A high-dimensional left-tail interdependence perspective. *Energy Econ.* 89. <https://doi.org/10.1016/j.eneco.2020.104761>





## Economic Growth and Convergence: Implications of Energy Transition Pathways

Nader AlKathiri, KAPSARC, +966554424643, Nader.AlKathiri@kapsarc.org  
Abdulelah Darandary, KAPSARC, +966501912777, Abdulelah.Darandary@kapsarc.org

### Overview

The Solow growth model predicts that developing countries should catch up to the rich. The premise of the Solow model is simple, given access to the same technology, developing countries with lower capital stock should have a higher marginal product of capital and grow faster as they accumulate capital. While the conditional convergence hypothesis has found robust support in the data, unconditional convergence – that is, the hypothesis that subsequent growth rates should be unconditionally negatively related to initial per capita incomes - did not manifest in the data. For decades the literature could not find empirical evidence that supports the existence of unconditional convergence and was only found in specific sectors (see Rodrik (2013) and AlKathiri (2022)). This all changed after recent studies using the most recent data demonstrated that since the mid-1990s, the world has entered a new era of unconditional convergence (see Kremer et al. (2021) and Patel et al. (2021)).

This paper aims to contribute to the narrative of the observed unconditional convergence by assessing the role of energy. Specifically, did energy have a particular role to play in the observed unconditional convergence period? Our findings show that unconditional convergence in the last two decades is associated with higher growth of per-capita energy consumption of developing countries relative to rich ones, which was not the case in earlier periods. In addition, we exploit an extended production function specification that includes energy and show the different role of energy in impacting economic growth for countries of three income groups. The elasticity of GDP with respect to energy is higher in low-income countries relative to rich countries.

### Methods

Let  $\hat{y}_{i,t,t+\Delta t}$  be the growth rate of income per capita during the periods  $t$  and  $t + \Delta t$ , and  $\log(y_{i,t})$  be the natural logarithm of income per capita for country  $i$  at time  $t$ . Consider the following model:

$$\hat{y}_{i,t,t+\Delta t} = \alpha + \beta \log(y_{i,t}) + \varepsilon_{i,t} \quad (1)$$

Suppose we estimate the coefficients and find  $\beta < 0$ , we say there is unconditional convergence in income, as developing countries tend to grow faster than rich ones. This paper investigates the role of energy in deriving patterns of cross-country income growth. Therefore, we look at the evolution of growth in per-capita energy consumption and how it relates to the initial income level. Let  $e_{i,t}$  be the level of energy consumption per capita for a country and  $\hat{e}_{i,t,t+\Delta t}$  be its annualized growth rate. We estimate the following regression to test for the contribution of energy to convergence during different periods:

$$\hat{e}_{i,t,t+\Delta t} = \alpha + \gamma \log(y_{i,t}) + \varepsilon_{i,t} \quad (2)$$

We say energy consumption contributes to cross-country income convergence if  $\gamma < 0$ . We also examine the energy consumption elasticity of income and whether it differs across income groups. Consider the following extended Cobb-Douglas production function  $Y = F(L, K, E) = A L^{\beta_1} K^{\beta_2} E^{\beta_3}$  with output ( $Y$ ) and three factors of production: Labor ( $L$ ), capital ( $K$ ), and energy ( $E$ ). By taking the log of both sides, one can get the following estimation equation:

$$\log(Y_{it}) = \alpha_i + \beta_1 \log(L_{it}) + \beta_2 \log(K_{it}) + \beta_3 \log(E_{it}) + \varepsilon_{it} \quad (3)$$

Where the slope coefficients  $\beta_s$  are elasticities of output with respect to each factor of production.

### Results

Our analysis covers the period from 1980-2019 for 103 countries. We focus our convergence analysis on two periods, 1980-2000 and 2000-2019. Our results reconfirm the findings of recent studies that poorer countries tend to grow faster than rich countries for the 2000-2019 period, which was absent in the period before. During the pre-convergence period (1980-2000), average per-capita energy consumption growth tended to be similar for both developing and developed countries. On the other hand, the period of 2000-2019 is associated with faster per-capita energy consumption in developing countries relative to developed countries.



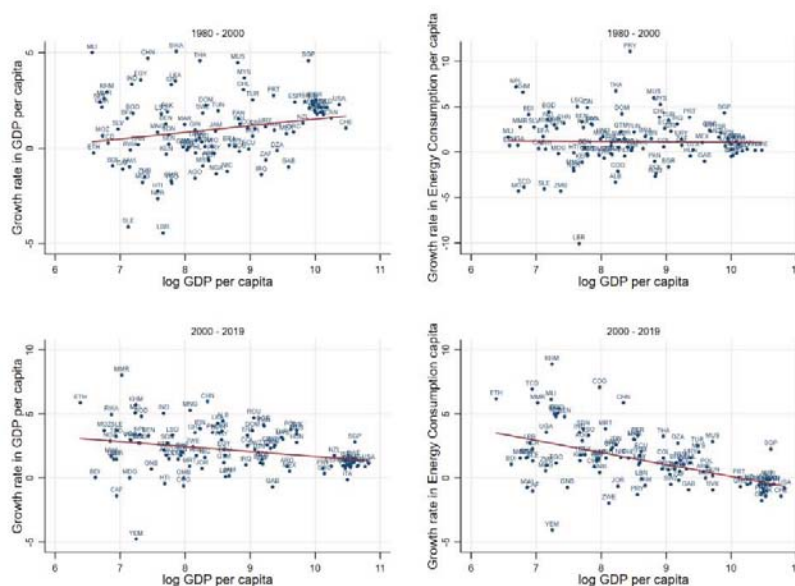


Figure 1: Scatter plots of 1) growth of income per capita on initial income (left) 2) growth of energy consumption per capita on initial income (right)

We also estimate the energy consumption elasticity of income. Table 1 shows the elasticities estimates for the total sample and income groups. On average, a 10 percent increase in energy consumption is associated with a 1.7 percent increase in GDP. Estimates by income group show that low-income countries have a higher elasticity than middle- and high-income countries.

Table 1: Regressions of GDP per capita on energy consumption per capita

	(1) All Countries	(2) Low Income	(3) Middle Income	(4) High Income
Energy (E)	0.17***	0.26***	0.08***	0.03
Capital stock (K)	0.49***	0.35***	0.55***	0.62***
Labor (L)	0.34***	0.42***	0.33***	0.68***
Constant	3.61***	4.45***	3.27***	1.98***
Obs.	4101	1031	2040	1030
R-squared	0.86	0.82	0.89	0.91

Note: All variables are in natural logarithms. The dependent variable is GDP (Y). Standard errors are in parentheses \*\*\* p<0.01, \*\* p<0.05, \* p<0.1

## Conclusions

This paper emphasizes that the unconditional convergence observed in the last two decades is associated with higher growth of per-capita energy consumption of developing countries relative to rich ones. We also estimate the energy consumption elasticity of income and show that low-income countries have a higher elasticity than middle- and high-income countries. These findings demonstrate that energy access is imperative for developing countries to enable them to catch up to developed countries. The onset of COVID19 has accelerated the global climate agenda, and countries are speeding up the energy transition. However, transition efforts remain challenging due to constraints, lack of collective action, and coordination. As a result, consequences such as volatile energy prices and materials bottlenecks have ensued. If these trends continue, lower energy access will impede economic growth rates for many developing economies, which would undo decades of catching up and weaken policy action. It is critical to identify flexible options to transition without undermining the energy needs of low-income countries to grow their economies. The Circular Carbon Economy framework enables inclusive and smooth energy transition pathways to a sustainable and low carbon future, benefiting both developing and developed countries.

## References

- AlKathiri, N. (2021). Labour productivity growth and convergence in manufacturing: A nonparametric production frontier approach. *Applied Economics*, 54(4), 1–24.
- Kremer, M., Willis, J., & You, Y. (2021). *Converging to convergence* (No. w29484). National Bureau of Economic Research.
- Patel, D., Sandefur, J., & Subramanian, A. (2021). The new era of unconditional convergence. *Journal of Development Economics*, 152, 102687.
- Rodrik, D. (2013). Unconditional convergence in manufacturing. *The Quarterly Journal of Economics*, 128(1), 165–204.





## Oil Price Cycles and The Choice of Private vs Public Schools

Abdullah Almansour, KFUPM Business School

### Overview

Macro-exogenous shocks that adversely affect human capital accumulation may have a lasting impact because investment in human capital takes place at critical stages and cannot be postponed. Economies that rely heavily on income from extracting natural resources are subject to the high volatility that characterizes the natural resources market and are thus subject to negative and frequent macro shocks. Accordingly, investments in human capital in such countries may be adversely affected. In this study, we show how in Saudi Arabia, a country that relies heavily on crude oil exports, negative shocks in crude oil prices can impact households' decisions to invest in education. There are approximately 14 percent of Saudi students in the country who attend private schools that charge fees to provide educational services. While 14 percent might sound low, the pace of growth in the number of Saudi students attending private schools, especially international schools, is very strong, much stronger than that of public schools. The paper investigate how the growth in private schools enrolment is affected by the oil down cycle of mid 2014.

### Methods

We use the oil down cycle that started in the second half of 2014 to empirically study its impact on the choice of public vs private school by *Saudi parents* who lives in Saudi Arabia, a country that relies much on oil revenues. Public schools in Saudi Arabia are tuition-free schools while private schools charges tuition fees. Private schools can be *national private* schools, which teach national curricula or *international schools*, which teach international curricula and tend to charge relatively higher fees. We collect data on K-12 school enrolment in all three school types across all the Ministry of Education's offices in Saudi Arabia from 2013-2021. We then run series of regressions to study the impact of the oil down cycle on the dynamic of enrolment. We use the data to examine first what explain the choice of private vs public schools and then we investigate the impact of the oil down cycle on the number of Saudi students in both types of private schools.

### Results

we find that the oil-down cycle that started in the second half of 2014 compelled parents to abstain from sending their children to and, in some cases, de-enroll their children from tuition-based private schools, which are perceived to provide better quality education. Parents enrolled the children in free public schools. The impact of the shock on private school enrolment differs according to the type of school. In national private schools that teach national curricula, the growth rate of Saudi students dropped from 6 percent during the period before the shock to reach -3.8 percent in the academic year of 2018. Whereas, in international private schools that teach international curricula and tend to charge higher fees, the growth rate dropped from 40 percent before the shock to 23.8 percent in the academic year of 2017. We also find that the pace of rebound in national private schools, once the oil prices start to rebound, varies significantly across cities, sex, and educational levels, indicating a heterogeneous impact of the shock.

### Conclusions

The propagation of oil market volatility to the choice of schools by parents the pursuit of better quality education have important implications for both parents and policymakers. Parents may find it very hard to maintain the quality of education under the uncertainty of the income they earn, which may have a permanent impact on the human capital accumulation of their children. The government, with lower level of oil revenues in down cycles, may find itself under greater pressure to allocate more resources to education to accommodate extra students who might switch from private to public schools, affecting the quality of education. Although this study focuses on the adverse impact of oil shocks on education, other government services, particularly health services, are also expected to be impacted by oil shocks in a similar fashion. This emphasizes the importance of shielding the economy from the volatility of the oil market.



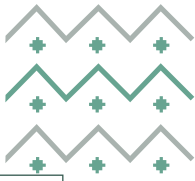




## References

1. Alvarez, R. and Vergara, D. (2016). Natural Resources and Education: Evidence from Chile. Working Papers wp433, University of Chile, Department of Economics.
2. Baumeister, C. and Kilian, L. (2016). Understanding the Decline in the Price of Oil since June 2014. Journal of the Association of Environmental and Resource Economists, 3(1):131–158. Publisher: The University of Chicago Press.
3. Bernanke, B. S. (1983). Irreversibility, Uncertainty, and Cyclical Investment\*. The Quarterly Journal of Economics, 98(1):85–106.
4. Blanchard, E. and Olney, W. (2015). Globalization and Human Capital Investment: How Export Composition Drives Educational Attainment. Department of Economics Working Paper 2013-18, Department of Economics, Williams College.
5. Cust, J. and Poelhekke, S. (2015). The Local Economic Impacts of Natural Resource Extraction. Annual Review of Resource Economics, 7(1):251–268. eprint: <https://doi.org/10.1146/annurev-resource-100814-125106>.
6. Dixit, R. K. and Pindyck, R. S. (1994). Investment under Uncertainty.
7. Douglas, S. and Walker, A. (2017). Coal Mining and the Resource Curse in the Eastern United States. Journal of Regional Science, 57(4):568–590. eprint: <https://onlinelibrary.wiley.com/doi/pdf/10.1111/jors.12310>.
8. Ebeke, C., Omgba, L. D., and Laajaj, R. (2015). Oil, governance and the (mis)allocation of talent in developing countries. Journal of Development Economics, 114:126–141.
9. Flug, K., Spilimbergo, A., and Wachtenheim, E. (1998). Investment in education: do economic volatility and credit constraints matter? Journal of Development Economics, 55(2):465–481.
10. Grigoli, F., Herman, A., and Swiston, A. (2019). A crude shock: Explaining the short-run impact of the 2014–16 oil price decline across exporters. Energy Economics, 78:481–493.
11. Gylfason, T. (2001). Natural resources, education, and economic development. European Economic Review, 45(4):847–859. 15th Annual Congress of the European Economic Association.
12. McGuirk, E. F. (2013). The illusory leader: natural resources, taxation and accountability. Public Choice, 154(3):285–313.
13. Mousavi, A. and Clark, J. (2021). The Effects of Natural Resources on Human Capital Accumulation: A Literature Survey. Journal of Economic Surveys, 35.
14. Papyrakis, E. and Raveh, O. (2014). An Empirical Analysis of a Regional Dutch Disease: The Case of Canada. Environmental and Resource Economics, 58(2):179–198.





## DEPLOYING NATIONAL GAS EXPANSION STRATEGY AND THE SMART TOWNS URBANIZATION NEXUS TO STIMULATE SUSTAINABLE ECONOMIC DEVELOPMENT

Tubi O. Theophilus, University of Ibadan/NISER, +2348034370667, tubiotheophilus@gmail.com  
Adenikinju, Adeola F., University of Ibadan, +2348023440018, adeolaadenikinju@yahoo.com

### Highlights

- Concepts and models of Global Smart Systems were reviewed.
- Concept of Intelligent Buildings (IB) was expanded to structures, as all structures can now be made "Smart".
- Definitions of Intelligent Structures (IS) and Smart Structures (SS) are given in light of emerging realities.
- Objectives and driving forces of current projects were determined.
- Multiplier and Sustainability Effects of all aspects of its Socioeconomic and Environmental impacts determined.
- Gaps and barriers to full nexus integration in Nigeria were investigated and solutions provided.
- Actions and (Policy Plans) recommendations for various stakeholders are put forward.

### Overview

This study aims to contribute to the growing body of specialized knowledge focusing on the strategic adaption of innovative, affordable, and sustainable technology, systems thinking, and practices as well as linkage tactics in particular, aimed at achieving sustainable development goals through the harmonization of both Gas expansion policy to stimulate economic development and the smart towns urbanization nexus, in relation to the newly adopted Energy Transition Plan (ETP) given the daunting socioeconomic challenges in Nigeria.

### Methods

In investigating whether this linkage is practical and sustainable, we adopted and adapted the Triple Helix System analytical framework which is an analytical construct that synthesizes the key features of the National Gas Expansion Strategy (Government) – Industry – Smart Town Urbanisation (Triple Helix) interactions into an 'innovation system' format, defined according to Systems Theory as a set of components, relationships, and functions. Of the Triple Helix systems components, we made a distinction between (a) R&D and non-R&D innovators; (b) 'single-sphere' and 'multi-sphere' (hybrid) institutions; and (c) individual and institutional innovators.

### Results

The relationships between components are synthesized into five main types: Technology Transfer; Collaboration and Conflict Moderation; Collaborative Leadership; Substitution; and Networking. The overall function of Triple Helix systems - knowledge and innovation generation, diffusion, and use – is realized through a set of activities in the knowledge, innovation, and consensus spaces. We recommended the application of an integrated energy management system (EMS) based on IoT technology to all critical structures. results show that according to the three characteristics of the Internet of Things (IoT) "Sensor, Internet, Intelligent", the problem of data connection between IS EMS and IoT is solved.

At the end of our exhaustive process, the study proposes an "Integrated Framework" that provides practical suggestions on actualizing the harmonization of the series of policy initiatives, the core strategies for implementation, the various enabling factors and core challenges to be addressed in the proposed blueprint.





## Conclusions

This integrated framework is intended as a step-wise design instrument for policymakers and practitioners not only in Nigeria but throughout SSA due to its wide applicability.

## References

Zhang, W., & Yue, M. (2021). The application of building energy management system based on IoT technology in smart city. *International Journal of System Assurance Engineering and Management*, 12(4), 617-628.

Ye, L. (2020). Study on embedded system in monitoring of intelligent city pipeline network. *Computer Communications*, 153, 451-458.

Thai, C., & Brouwer, J. (2021). Challenges estimating distributed solar potential with utilization factors: California universities case study. *Applied Energy*, 282, 116209.

Surya, B., Muhibuddin, A., Suriani, S., Rasyidi, E. S., Baharuddin, B., Fitriyah, A. T., & Abubakar, H. (2021). Economic evaluation, use of renewable energy, and sustainable urban development Mamminasata Metropolitan, Indonesia. *Sustainability*, 13(3), 1165.

Barau, A. S., Abubakar, A. H., & Ibrahim Kiyawa, A. H. (2020). Not there yet: mapping inhibitions to solar energy utilisation by households in african informal urban neighbourhoods. *Sustainability*, 12(3), 840.

Ranga, M., & Etkowitz, H. (2015). Triple Helix systems: an analytical framework for innovation policy and practice in the Knowledge Society. *Entrepreneurship and knowledge exchange*, 117-158.

Panu, M., Zhang, C., El-Halwagi, M. M., Davies, M., & Moore, M. (2021). Integration of Excess Renewable Energy with Natural Gas Infrastructure for the Production of Hydrogen and Chemicals. *Process Integration and Optimization for Sustainability*, 5(3), 487-504.

Liang, Y., Zheng, J., Wang, B., Zheng, T., & Xu, N. (2020). Optimization design of natural gas pipeline based on a hybrid intelligent algorithm. In *Recent Trends in Intelligent Computing, Communication and Devices* (pp. 1015-1025). Springer, Singapore.

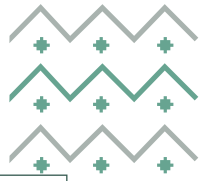
SEforAll (2022a) Sustainable Energy For All Geospatial Inception document. Nigeria Integrated Energy Plan Executive Summary. Retrieved 18:15pm, 02-Sept., 2022 from ([https://www.seforall.org/system/files/2022-01/Nigeria\\_IEPT-Executive\\_Summary.pdf](https://www.seforall.org/system/files/2022-01/Nigeria_IEPT-Executive_Summary.pdf))

SEforAll (2022b) Sustainable Energy For All Press Release. Nigeria's Vice President H.E. Professor Yemi Osinbajo launches world-class Integrated Energy Planning Tool. Retrieved 18:18pm, 02-Sept., 2022 from (<https://www.seforall.org/system/files/2022-02/NigeriaIEP-press-release.pdf>)

FGN ETP (2022a) Nigeria's Energy Transition Plan - Investing In Nigeria's Energy Transition Opportunity. Retrieved 19:20pm, 02-Sept., 2022 from (<https://www.energytransition.gov.ng/wp-content/uploads/2022/05/Investing-in-Nigeria-Energy-Transition.pdf>)

FGN ETP (2022b) Nigeria's Energy Transition Plan. Retrieved 19:20pm, 02-Sept., 2022 from (<https://www.energytransition.gov.ng/>)





## Is institutional quality the missing piece between economic growth and CO<sub>2</sub> Emissions?

[Alanda Venter, Department of Economics, University of Pretoria, alandav@mweb.co.za]  
 [Roula Inglesi-Lotz, Department of Economics, University of Pretoria, roula.inglesi-lotz@up.ac.za]

### Overview

On 12 December 2015, COP21 was implemented, where 196 parties came together with one goal in mind – to limit global warming. As COP21 states, one way to limit global warming is to reach a global peak of greenhouse gas emissions as soon as possible (Unfccc, 2015). A large contributor to greenhouse gas emissions is CO<sub>2</sub> emissions. To reduce CO<sub>2</sub> emissions, most countries focus on decreasing emissions in the energy sector – particularly in the electricity and heat sectors which contributed 43% of total CO<sub>2</sub> emissions in 2019 (Data Explorer | Climate Watch, 2022; Ritchie & Roser, 2020). A challenge most of these countries experience is reducing CO<sub>2</sub> emissions while sustaining economic growth, a possible solution to this challenge might be to account for the effect of institutional quality. This study examines potential pairwise relationships between economic growth and CO<sub>2</sub> emissions while considering institutional quality.

### Methods

The study uses a panel dataset consisting of 106 countries for the time period 2003 to 2018. As per the World Bank divisions, the 106 countries were divided into four income groups – low-income, lower-middle-income, upper-middle-income and high-income countries. A traditional panel VAR model is used, that will treat the variables within the system as endogenous (Antonakakis et al., 2017). Within this PVAR model, the Generalized Method of Moments (GMM) is used (Abrigo & Love, 2016). The PVAR model is specified in Equation 1.

$$Y_{it} = A_1 Y_{it-1} + A_2 Y_{it-2} + \dots + A_n Y_{it-n} + B X_{it} + \mu_i + \varepsilon_{it} \quad (1)$$

Where  $Y_{it}$  is a (1xk) vector of the dependent variables while  $X_{it}$  represents a vector of (1xl) vector of exogenous covariates. The dependent variable-specific panels' fixed-effects and idiosyncratic errors are represented by  $\mu_i$  and  $\varepsilon_{it}$  respectively (Abrigo & Love, 2016). After estimating the PVAR models the Granger-causality is then estimated respectively to indicate if causal relationships between CO<sub>2</sub> emissions, GDP and institutional quality exist.

To test granger causality the following three equations will be used. For Equation 2 the study will test if GDP, the two institutional proxies and the institutional index Granger cause CO<sub>2</sub> emissions.

$$CO2emissions_{it} = \alpha_i + \sum_{k=1}^p \gamma_i^k CO2emissions_{i,t-k} + \sum_{k=0}^p \theta_i^k GDP_{i,t-k} + \sum_{k=0}^p \beta_i^k Institutions_{i,t-k} + \varepsilon_{i,t} \quad (2)$$

Likewise, to Equation 2, CO<sub>2</sub> emissions and two institutional proxies along with the institutional index will now be used to see if they Granger cause GDP respectively.

$$GDP_{it} = \alpha_i + \sum_{k=1}^p \gamma_i^k GDP_{i,t-k} + \sum_{k=0}^p \theta_i^k CO2emissions_{i,t-k} + \sum_{k=0}^p \beta_i^k Institutions_{i,t-k} + \varepsilon_{i,t} \quad (3)$$

For the last Granger causality test, we will test whether GDP and CO<sub>2</sub> emissions granger cause the two institutional proxies and the institutional index respectively.

$$Institutions_{it} = \alpha_i + \sum_{k=1}^p \gamma_i^k Institutions_{i,t-k} + \sum_{k=0}^p \theta_i^k GDP_{i,t-k} + \sum_{k=0}^p \beta_i^k CO2emissions_{i,t-k} + \varepsilon_{i,t} \quad (4)$$

### Results

Rostow's (1959) framework of the five stages of economic growth assists in describing the study's results. Low-income countries can often be classified in one of the following two stages – the traditional societies and the preconditions for the take-off. These countries are generally agricultural-prone countries where the societies do not necessarily have a scientific and technological perspective or are starting to develop within the preconditions for take-off stage. These countries have also started to commercialize their agricultural sector and have just started their manufacturing sector (Rostow, 1959). For these countries, the results indicated no causal relationships were found





between economic growth, CO<sub>2</sub> emissions and institutions. Countries that are in the third stage -the take-off stage usually will experience some short-term significant growth while industrialisation starts to occur and institutions start to take effect. The study's results indicate that for the third stage lower middle-income countries experience bidirectional causation between CO<sub>2</sub> emissions and majority of institutional factors, further it was also found that economic growth granger cause institutional factors. Rostow's (1959) fourth stage of growth -The drive to mature stage can be linked to the study's upper middle-income country's group. While this stage is known to occur over a long time, it is also known as a period where social welfare increases, technological advancement occurs and industrialization advances. The results resemble the description of Rostow's (1959) fourth stage as causation was found between CO<sub>2</sub> emissions, institutional factors, and economic growth. The study found that high-income countries can be linked to Rostow's (1959) fifth stage – High mass consumption. These countries experience high levels of consumption and production but are also moving to service-orientated countries, therefore, the study's results are in line and imply economic growth granger causes CO<sub>2</sub> emissions.

## Conclusions

With the rising threat of climate change, countries from all over the world came together during COP21 to take measures in combating climate change. One of their goals is to decrease greenhouse gas emissions. With the latter in mind, these countries look at their energy sectors, more specifically the electricity and heat sector as this sector contributes the largest portion of CO<sub>2</sub> emissions which in turn contributes to greenhouse gas emissions. Institutions may be the solution for countries who struggle to decrease emissions while sustaining economic growth. This study examines if pairwise causal relationships exist between CO<sub>2</sub> emissions and economic growth while considering institutional quality.

The overall results indicate that as developmental changes in the economies start to occur, causal relationships start to form. While no causal relationship was found for the low-income countries it is explained due to the countries being agricultural-prone economies as well as lack of scientific and technological perspectives (Rostow, 1959). Causal relationships were found for the two middle-income and high-income country groups as these countries have started to develop their economies to more industrial-prone economies where institutions start to play a role and economic growth is occurring along with increased energy demands.

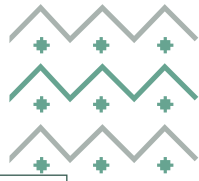
The difficulty most countries experience as mentioned by Stewart (2015), is that "the social, economic and environmental goals are not integrated" within countries policy frameworks which can be problematic. This study aims to assist policymakers on when to account for the integration of CO<sub>2</sub> emissions, economic growth, and institutional quality within their policy framework.

## References

- Abrigo, M. R. M., & Love, I. (2016). Estimation of panel vector autoregression in Stata. *The Stata Journal*, 16(3), 778–804.
- Antonakakis, N., Cunado, J., Filis, G., & Perez De Gracia, F. (2017). Oil dependence, quality of political institutions and economic growth: A panel VAR approach. *Resources Policy*, 53, 147–163.  
<https://doi.org/10.1016/j.resourpol.2017.06.005>
- Rostow, W. W. (1959). Source: The Economic History Review. In *New Series* (Vol. 12, Issue 1).  
<https://about.jstor.org/terms>
- Stewart, F. (2015). The Sustainable Development Goals: a comment.  
<https://doi.org/10.1080/17449626.2015.1084025>, 11(3), 288–293.  
<https://doi.org/10.1080/17449626.2015.1084025>







## Resilience of Saudi Arabia's economy to oil shocks: effects of economic reforms

Hossa Al Mutairi, KAPSARC, [hossa.mutairi@kapsarc.org](mailto:hossa.mutairi@kapsarc.org)

Marzio Galeotti, KAPSARC and University of Milan, [marzio.galeotti@kapsarc.org](mailto:marzio.galeotti@kapsarc.org)

Baltasar Manzano, KAPSARC and Universidade de Vigo, [baltasar.manzano@kapsarc.org](mailto:baltasar.manzano@kapsarc.org)

Axel Pierru, KAPSARC, [axel.pierru@kapsarc.org](mailto:axel.pierru@kapsarc.org)

### Overview

We assess the extent to which the implementation of Vision 2030 policies enhances the Saudi economy's resilience to shocks to the oil price and production, and to the productivity of tradable and non-tradable goods. We extend Blazquez et al.'s (2021) Dynamic Stochastic General Equilibrium model to capture the economic diversification policies and build a resilience index. We find that without economic diversification, policy reforms stimulating long-term economic growth, such as introducing a Value Added Tax, may increase the volatility of macroeconomic aggregates. However, when the economic diversification policy is accounted for, Vision 2030's economic policies lead to a less volatile, more resilient economy. Thus, the resilience of Saudi Arabia's GDP to oil price shocks increases by up to 60% (even if the oil price remains the main driver of macroeconomic fluctuations).

### Methods

To address the question of economic resilience, we extend K-DSGE, the dynamic stochastic general equilibrium model that Blazquez et al. (2021) use for their long-term analysis, by introducing public investment as a driver for economic diversification. Other model's modifications are also made. We define resilience as the capacity of an economy to resist a particular shock and recover rapidly to (or above) its pre-shock level. In this paper, we consider shocks to the oil price, shocks to oil production, and shocks to tradable goods and non-tradable goods productivity. We propose a quantification of Saudi economy's resilience before and after the implementation of the economic policies considered. We build a resilience index to shocks that summarizes the numerical information contained in the impulse response functions.

### Results

We find that introducing a VAT or domestic energy price reforms may increase the volatility of the Saudi GDP (even if these policies are beneficial to long-term economic growth). When the implemented policy package includes Vision 2030's economic diversification policies, the resilience of GDP to oil price shocks increases by up to 60%, depending on the time horizon and fiscal channel considered. The Saudi non-oil GDP becomes two to three times more resilient to oil price shocks.

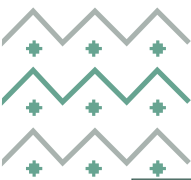
### Conclusions

With Vision 2030's economic policies, the Saudi economy becomes much more resilient to shocks. We quantify this with a resilience index based on impulse functions. Our results show that introducing a VAT or reforming domestic energy prices is beneficial to economic growth in the long term but does not render the economy more resilient. When the implemented policy package includes Vision 2030's economic diversification policies, the economy's resilience substantially increases.

### Reference

Blazquez, J., Galeotti, M., Manzano, B., Pradhan, S., Pierru, A., 2021. Effects of Saudi Arabia's economic reforms: Insights from a dynamic stochastic general equilibrium model. *Economic Modelling* 95: 145–169.





## *Energy Subsidies Reform and Homebuyer Choices: Evidence from Saudi Arabia*

Hussain Alshammasi, King Fahd University of Petroleum and Minerals, +966 506881969, [hashammasi@kfupm.edu.sa](mailto:hashammasi@kfupm.edu.sa)  
Abdullah Mohammed Almansour, King Fahd University of Petroleum and Minerals, +966 505924305, [amansour@kfupm.edu.sa](mailto:amansour@kfupm.edu.sa)

### 11.5. Energy and the Economy – Other

#### Overview

Acquiring a home is arguably the largest decision made by ordinary households, and represents the largest share of their lifetime income. It is, therefore, essential for researchers and policymakers to determine the factors that affect the choices of homebuyers. Evidence in the energy economics literature shows that homebuyers are attentive to energy costs, just like other characteristics of the property. Home prices, for instance, are affected by the type of fuel or heating systems installed in the house and fluctuations in energy prices (Myers 2019). In countries where energy is immensely subsidized, how do homebuyer preferences change due to changes in residential electricity tariffs?

The objective of this research is to answer two main questions to understand how homebuyers respond to an increase in electricity prices: (1) Do homebuyers prefer smaller housing units when energy prices increase? and (2) how does the response vary across income groups? We investigate the two questions in the context of Saudi Arabia, where the once heavily subsidized energy prices have gradually increased since 2016 in a governmental effort to rationalize consumption and fiscal spending.

Holding everything else constant, we find that homebuyers prefer larger houses when energy prices are low and prefer smaller housing units when energy prices increase. The response of homebuyers to energy prices, however, is not equal across different income groups. We find evidence that the response of lower- and middle-income groups is significantly larger than that of high-income groups when energy prices increase.

While the impact of tariff changes on electricity demand and the environmental impacts in Saudi Arabia have been modeled in recent studies (Aldubyan and Gasim, 2021; Matar, 2018), we are unaware of economic research studies that study the effect of the electricity tariff change directly on the prices of residential property. The effect of energy costs on home buying decisions, however, has been studied in other contexts. Myers (2019) studies whether homebuyers are responsive to variations in energy prices by comparing oil-heated homes and gas-heated homes in the US and finds that homebuyers are attentive to energy costs. Chegut, Eichholtz, and Holtermans (2016) find that energy efficient homes have a premium over less efficient homes in the Netherlands. Pride, Little, and Mueller-Stoffels (2018) find that energy efficient homes sell for a premium in Alaska, US, compared to less efficient homes.

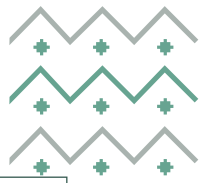
Our study contributes to the strand of literature that studies the effect of energy prices on consumer behavior, as well as the literature that addresses the challenges of subsidies reform, especially in Middle Eastern countries (Rodriguez and Flores, 2015; Verme, 2017). We also contribute to the literature on the distributional impacts (with respect to income levels) of energy subsidies. See for example (Giuliano, 2020; Guenette, 2020; Ilyas, et al., 2022; Metcalf, 2019). Our findings also contribute to the real estate and urban economics literature that focuses on the impacts of energy expenses on the market for residential properties (Aydin et al., 2020; Brewer, 2022).

#### Methods

We obtain a rich panel dataset of properties sold between 2011 and 2022 in the Kingdom of Saudi Arabia, made available by the Ministry of Justice (MoJ). We observe the date of transaction, value of transaction, type of property, detailed location, and size of the property measured by its land area. Being able to track the same property over time, we exploit the exogenous nature of the price change to study the effect of Jan-2016 electricity tariff change on the prices of residential property (houses, apartments, and land).

We use OLS regression models with various level of time, location, and property fixed effects to identify the impact of the subsidy change on the price per square meter of properties in different size groups (small properties, medium properties, and large properties). The identifying assumption is that the price change is exogenous and uncorrelated with unobserved time-variant and time-invariant variables of the property. We also construct a proxy measure for income at the neighborhood level in the country using the price per square meter of land in the neighborhood in each year. We then use this measure to construct 3 groups of income levels (low-income, middle-income, and high-income) based on the terciles of this measure in each city in each year. The measure is interacted with size to estimate the response of each income group.





## Results

Our results do suggest that the increase in electricity prices caused the price per square meters to decrease proportionally more in larger properties than in smaller properties. This finding indicates that homebuyers are attentive to energy costs, as larger properties are correlated with larger energy bills. The results are robust to different specifications of the fixed effects and to a placebo test in which we use a false intervention period. Using our measure of income, we also find that low-income groups are more significantly affected by the price change as opposed to the middle-income group and high-income groups. This suggests that the price change is regressive.

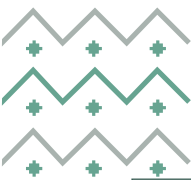
## Conclusions

Energy policy requires understanding of how consumers respond to changes in energy prices. This study investigates how residential consumers respond to electricity tariff changes. We study this effect using a large dataset of housing market transactions in Saudi Arabia. The detailed transactions allow us to construct a panel data in which we track properties within the same neighbourhood. We find evidence that the choices of homebuyers were influenced by the electricity tariff change that took place in 2016. The price per square meter in smaller housing increased proportionally more than the price per square meter in larger units. We also find evidence that low-income homebuyers are more responsive to the price change. These results are relevant to policy makers with regards to the design of subsidies reform policy.

## References

- Aldubyan, M., & Gasim, A. (2021). Energy price reform in Saudi Arabia: Modeling the economic and environmental impacts and understanding the demand response. *Energy Policy*, 148, 111941.
- Aydin, E., Brounen, D., & Kok, N. (2020). The capitalization of energy efficiency: Evidence from the housing market. *Journal of Urban Economics*, 117, 103243.
- Brewer, D. (2022). Equilibrium sorting and moral hazard in residential energy contracts. *Journal of Urban Economics*, 129, 103424.
- Chegut, A., Eichholtz, P., & Holtermans, R. (2016). Energy efficiency and economic value in affordable housing. *Energy Policy*, 97, 39-49.
- Guenette, J. D. (2020). Price Controls: Good Intentions, Bad Outcomes. World Bank Policy Research Working Paper, (9212).
- Giuliano, F., Lugo, M. A., Masut, A., & Puig, J. (2020). Distributional effects of reducing energy subsidies: Evidence from recent policy reform in Argentina. *Energy Economics*, 92, 104980.
- Ilyas, R., Hussain, K., Ullah, M. Z., & Xue, J. (2022). Distributional impact of phasing out residential electricity subsidies on household welfare. *Energy Policy*, 163, 112825.
- Matar, W. (2018). Households' response to changes in electricity pricing schemes: bridging microeconomic and engineering principles. *Energy Economics*, 75, 300-308.
- Metcalf, G. E. (2019). The distributional impacts of US energy policy. *Energy Policy*, 129, 926-929.
- Myers, E. (2019). Are home buyers inattentive? Evidence from capitalization of energy costs. *American Economic Journal: Economic Policy*, 11(2), 165-88.
- Pride, D., Little, J., & Mueller-Stoffels, M. (2018). The value of residential energy efficiency in interior Alaska: a hedonic pricing analysis. *Energy policy*, 123, 450-460.
- Rodriguez, S., Pant, M., & Flores, J. (2015). Energy price reforms in the GCC: what can be learned from international experiences. IMF, Washington, DC.
- Saudi Electricity Company, 2022. <https://www.se.com.sa/ar-sa/Customers/Pages/TariffRates.aspx> . Last accessed June 10th, 2022.
- Verme, P. (2017). Subsidy reforms in the Middle East and North Africa region: A review. *The Quest for Subsidy Reforms in the Middle East and North Africa Region*, 3-31.





## ***THE ROLE OF THE CIRCULAR ECONOMY IN FOSTERING SUSTAINABLE ECONOMIC GROWTH IN THE-GCC***

Jawaher Ali Binsuwadan, Department of Economics, Princess Nourah bint Abdulrahman University, Riyadh PO Box 84428, Saudi Arabia, 00966553434555, [jabinsuwadan@pnu.edu.sa](mailto:jabinsuwadan@pnu.edu.sa)  
Ghadda Mohamed Yousif, Department of Economics, Princess Nourah bint Abdulrahman University, Riyadh PO Box 84428, Saudi Arabia, 00966509225734, [gmyousif@pnu.edu.sa](mailto:gmyousif@pnu.edu.sa)  
Hiyam Ahmed Abdulrahim, Department of Economics, Princess Nourah bint Abdulrahman University, Riyadh PO Box 84428, Saudi Arabia, 00966568370603, [haalrahim@pnu.edu.sa](mailto:haalrahim@pnu.edu.sa)

### **Overview**

The circular economy CE plays a pivotal role in global sustainable economic systems. Depending on linear production is not feasible nowadays, given the limited resources available and the rapid economic growth (Suárez-Eiroa et al., 2019). Production and consumption materials need to be recycled to improve the efficiency of using scarce natural resources. As such, current developments in the CE are addressing the heightened need for transforming linear economies into circular ones (Corona et al., 2019, Hysa et al., 2020). The CE concentrates on the optimal use of resources in order to achieve sustainable development, which in turn contributes to environmental, economic and social goals (Banaité, 2016, Rodriguez-Anton et al., 2019). Therefore, it is important to analyse the contribution of the CE in enhancing sustainable economic growth in different countries (Tantau et al., 2018, Corona et al., 2019, Busu and Trica, 2019).

There is a growing need to convert to CE especially in developing countries, as CE strategy helps these countries to be more sustainable in using their limited resources. Therefore, a new type of economic growth is proposed focusing on reducing, reusing and recycling production and consumption materials (Ngan et al., 2019). Adopting this conversion contribute to sustainability by improving environmental and economical performance without spending more costs on new resource or waste management (Tantau et al., 2018, Busu, 2019). The successful transition to CE is more important to developing countries, as it solves the waste and resource issues; thus, saving the future generation from incurring environmental and economic costs.

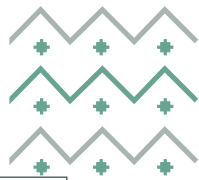
Although the CE plays a role in achieving economic sustainability, few studies have explored the effect of transitioning to a CE in developing countries. Therefore, it is essential to examine the effect of circular economic factors on economic growth. To address this research gap, this study attempts to analyse selected indicators of the CE in the Gulf Cooperation Council (GCC) countries by focusing on the environmental, social and economic components. The aim of this paper is to analyse and elaborate on the impact of the CE on the economic growth of GCC countries. Moreover, the paper attempts to examine the interrelation of economic, social and environmental factors and sustainability in the GCC economies.

The main question of this paper is how CE factors contribute to fostering economic growth in the GCC countries. Furthermore, determine which CE indicators affect economic growth positively. The study contributes to the literature by estimating the link between circular economy indicators and economic growth, which has not been done previously in developing countries. The study can also help in improving our knowledge of the emerging different empirical literature on CE transforming towards enhancing environmental and economic development.

### **Methods**

The sustainability of a CE is determined by the dependency of the main CE factors on GCC economic growth; this dependency is estimated using a regression model of economic growth, as a dependent variable, based on different explanatory variables such as CO<sub>2</sub> emissions, unemployment rate, electric power consumption, labour productivity, and renewable energy consumption. These independent variables are included in the model, based on the effects of each variable in previous literature (Trica et al., 2019). To fulfill the purposes of this paper, statistical hypotheses are validated by a multiple regression model using the statistical STATA software (StataCorp, 2015). The paper conducted a panel data for 6 GCC countries (Saudi Arabia, United Arab Emirates, Bahrain, Oman, Kuwait, and Qatar) to identify the effects of the CE indicators on economic growth. The data used in the regression model are collected from the World Bank database and correspond to the 2000– to 2020 time frame. The model is estimated first by the Ordinary Least Squares, followed by the Fixed and Random-Effects model which considers the panel effects of the dataset.





## Results

Investigating the CE indicators based on the results of our economic model contribute to the empirical literature on CE transition in GCC countries. The indicators' statistical analysis reveals that the data has a normal distribution. To decide whether to adopt a fixed or random effect model, a Hausman test is performed. The test's findings demonstrated that fixed effect models were the most suitable ones for our situation. According to the estimation's findings, CO<sub>2</sub> significantly and favorably influences the GCC nations' per-capita economic growth at the 0.01 level of significance. The f-statistics were found to be significant, confirming the model's overall significance. We underline that 82% of the variability of the dependent variables is explained by explanatory variables due to the R<sup>2</sup> value of 0.82. The explanatory factors were tested for multicollinearity using Pearson correlation analysis. Since the correlation coefficient between the independent variables is less than 0.5, multicollinearity between the variables cannot be inferred.

## Conclusions

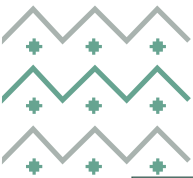
This aim of the present study is to explore the relationship between the CE and economic growth in the GCC countries by using the multi-regression model. The study has been one of the first attempts to thoroughly examine economic, social and environmental influences on GCC economic growth. It highlighted the importance of the transition to CE in developing countries, and that the relationship can be observed in different variables which affect the economic growth. Based on the results of the multi regression analysis, the most obvious finding to emerge is that CO<sub>2</sub> significantly affects the GCC countries per-capita economic growth. Further research could be carried out to measure the impact of these explanatory variables on the sectoral level on GCC economies. A considerable policy implication of this study, is to maintain CO<sub>2</sub> as a driver for fostering the economic growth of the GCC countries.

## References

- BANAITE, D. 2016. Towards circular economy: analysis of indicators in the context of sustainable development. *Social Transformation in Contemporary Society*, 4, 142-150.
- BUSU, M. 2019. Adopting circular economy at the European Union level and its impact on economic growth. *Social Sciences*, 8, 159.
- BUSU, M. & TRICA, C. L. 2019. Sustainability of circular economy indicators and their impact on economic growth of the European Union. *Sustainability*, 11, 5481.
- CORONA, B., SHEN, L., REIKE, D., CARREÓN, J. R. & WORRELL, E. 2019. Towards sustainable development through the circular economy—A review and critical assessment on current circularity metrics. *Resources, Conservation and Recycling*, 151, 104498.
- HYSA, E., KRUIA, A., REHMAN, N. U. & LAURENTI, R. 2020. Circular economy innovation and environmental sustainability impact on economic growth: An integrated model for sustainable development. *Sustainability*, 12, 4831.
- NGAN, S. L., HOW, B. S., TENG, S. Y., PROMENTILLA, M. A. B., YATIM, P., ER, A. C. & LAM, H. L. 2019. Prioritization of sustainability indicators for promoting the circular economy: The case of developing countries.
- RODRIGUEZ-ANTON, J., RUBIO-ANDRADA, L., CELEMÍN-PEDROCHE, M. & ALONSO-ALMEIDA, M. 2019. Analysis of the relations between circular economy and sustainable development goals. *International Journal of Sustainable Development & World Ecology*, 26, 708-720.
- STATA CORP, L. 2015. Stata Statistical Software: Release 14.[computer program]. *College Station, TX: StataCorp LP*.
- SUÁREZ-EIROA, B., FERNÁNDEZ, E., MENDEZ-MARTÍNEZ, G. & SOTO-OÑATE, D. 2019. Operational principles of circular economy for sustainable development: Linking theory and practice. *Journal of cleaner production*, 214, 952-961.
- TANTAU, A. D., MAASSEN, M. A. & FRATILA, L. 2018. Models for analyzing the dependencies between indicators for a circular economy in the European Union. *Sustainability*, 10, 2141.
- TRICA, C. L., BANACU, C. S. & BUSU, M. 2019. Environmental factors and sustainability of the circular economy model at the European Union level. *Sustainability*, 11, 1114.







***NATURAL GAS EXPORT CAPACITY AND DOMESTIC CONSUMERS: A TALE OF TWO AUSTRALIA'S***

Mathew Horne  
 Senior Researcher, APERC  
 +81 80 8855 1863  
 mathew.horne@aperc.or.jp

**Overview**

The energy market tumult brought on by Russia-Ukraine conflict has transmitted all the way to Australia's east coast, with meteoric price rises for both natural gas and electricity. But on the west coast of Australia, energy prices have remained relatively stable. This contrasting experience is largely due to divergent energy policies telling a tale of two Australia's.

As of 2021, Australia was the seventh largest global producer of natural gas, with almost three-quarters of its production exported via LNG. Expanding volumes of gas exports were enough for Australia to surpass Qatar as the largest global LNG exporter in 2021 (none of Australia's natural gas is traded via pipeline due to the tyranny of distance).

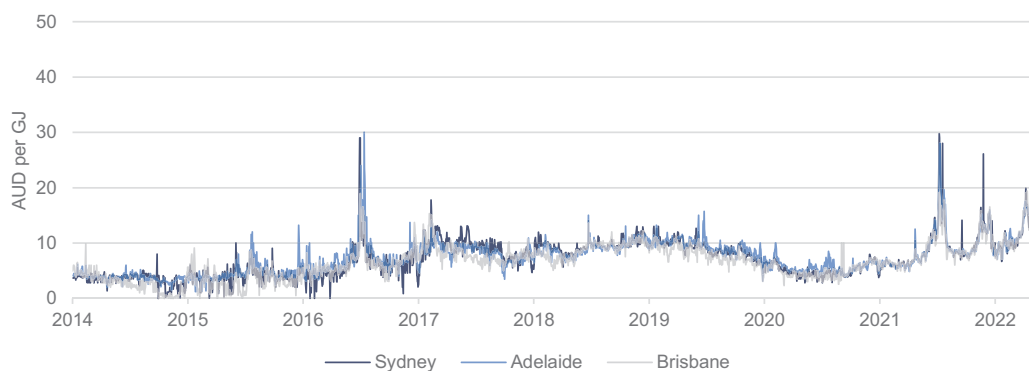
Almost two-thirds of Australia's natural gas production is from Western Australia. Exports are the driving force for Western Australian natural gas production, though to receive approval, natural gas export projects are required to make approximately 15% of their production available for domestic consumers. This certainty of supply delivers western consumers a dependable stream of natural gas that is little influenced by international market developments.

On the east coast, where most Australians live, domestic supply certainty is not so assured.

Rapidly expanding appetites for natural gas in Asia spurred development of LNG exporting facilities out of Gladstone, Queensland in the early-2010s. Gorgon LNG (GLNG), Asia Pacific LNG (APLNG), and Queensland Curtis LNG (QCLNG) committed to building two LNG trains each, with their supply dependent on the development of unconventional coal seam gas out of Queensland's Surat and Bowen basins.

A quarter of a century after the first LNG cargo was shipped from Western Australia, the first east coast LNG cargo was shipped in late 2014. Before the development of this export capacity, east coast consumption of natural gas mostly flowed from conventional gas sources from southern Australia, with wholesale prices averaging AUD 4 per GJ (Figure 1).

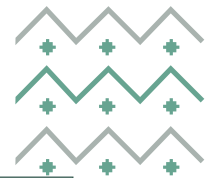
**Figure 1: Australian east coast short-term trading market for natural gas (AUD per GJ)**



Source: AEMO (2022)

At the same time as the east coast LNG exporters began to ship their cargoes to Asia, production from conventional sources in the southern regions of Australia began to decline, which led to a tightening in the domestic market for natural gas.





Part of this tightening was due to multiple state-based moratoriums on natural gas exploration in the southern states of Australia. The tightness was exacerbated because there was no requirement for the east coast LNG exporters to cordon off a portion of their production for domestic consumers, as is the case on the west coast.

To add to the woes of the east coast market, production from the Surat and Bowen basins has been less productive than anticipated. This has meant that the LNG exporters have consistently had less gas available for liquefaction than they had planned on.

Low production from these basins has meant that the LNG exporters have become the marginal buyer of conventional supplies of gas from the domestic market, linking domestic east coast natural gas prices to prices in Asia. Wholesale domestic natural gas prices began to spike in 2016 due to this relationship, with average spot prices more than doubling from their historic levels (Figure 1).

The Australian Domestic Gas Security Mechanism (ADGSM) was instituted as an initial response to the gas price spikes, though the mechanism does not provide the same amount of supply certainty as the domestic reservation requirement on the west coast. The Federal government also instituted a Heads of Agreement with the east coast LNG exporters to attempt to ensure domestic supply is prioritised ahead of international buyers, based on certain considerations.

But in the face of extreme supply disruptions, such as those brought on by the Russia-Ukraine conflict, both policy measures have proven ineffective in shielding east coast businesses and consumers who rely on natural gas. Natural gas prices have been spiking to unprecedented levels, with wholesale spot prices increasing to more than AUD 40 per GJ at the beginning of the southern hemisphere winter (Figure 1). Electricity prices have also moved parabolic given that natural gas generation is often the marginal supplier of electricity during periods of peak demand.

In contrast, Australia's domestic west coast market has been largely unaffected for 2022, with the domestic reservation policy more robust than the measures implemented on the east, in terms of shielding domestic consumers from supply shocks (and associated price spikes). This shielding comes at the expense of international consumers, with less available international supply, and diminished revenue for the exporters.

## Methods

This paper will investigate policy settings for the separate natural gas markets on both sides of the Australian continent, and how this impacts natural gas prices and surety of supply for domestic consumers. The policy implications for global supply will also be explored.

## Results

This investigation is ongoing and dependent on additional research.

## Conclusions (preliminary)

East coast demand for natural gas has already been waning in recent years due to higher uncertainty of supply, and higher prices. Incentivising an appropriate amount of additional supply is a challenge in the context of falling demand and made even more challenging with various exploration moratoria still in place.

East coast Australia consumers are currently subject to the same economic pain that European consumers are facing. Federal government intervention to negotiate a better deal on consumers' behalf, at the expense of the LNG exporters, is perhaps justifiable. But such an intervention will raise Australia's sovereign risk.

Potential courses of action could be to impose a 'war tax' on the LNG exporters, on the justification that investors should not necessarily benefit from the human misery of war. For example, the UK instituted a 25% windfall tax on oil and gas producers in response to the Russian invasion, with the proceeds intended to partially ease the large increases in household and business energy bills. Alternatively, some sort of domestic reservation policy could be beneficial on the east coast. But the LNG exporters in the east will push back against such a policy to protect their profits.

## References

ACCC (2022), Gas inquiry 2017–2025, Interim report (July 2022), Commonwealth of Australia, <https://www.accc.gov.au/publications/serial-publications/gas-inquiry-2017-2025/gas-inquiry-july-2022-interim-report>





## Economic Impacts of Investment in Renewables for Energy Exporters with Oil Price Uncertainty: A Diversification Strategy?

Christopher M. Hannum, University of Central Asia, +992 93 888 6400, christopher.hannum@ucentralasia.org

IAEE Specialization Code 11.4: energy and the economy – energy shocks and business cycles

### Overview

Renewables are a viable risk-reduction strategy, analogous to long-term contracts, diversification or import substitution for energy importing countries and regions. Can they serve a similar role in risk reduction as part of the production portfolio for energy exporting countries and regions?

The sources of risk that importers face are chiefly price stability, but also supply stability. Renewable output does not follow the same cyclical pattern as global fossil fuel prices, allowing a system-wide reduction in risk (to GDP or welfare) as renewables displace oil/gas/coal in electricity generation and/or transportation. Importers seek to minimize the potential GDP or welfare losses of high energy prices and/or energy supply shortfalls. This is the source of downside risk. Exporters seek to minimize the potential GDP or welfare losses of low energy prices and/or export supply constraints. Exporters also seek to minimize the potential GDP or welfare losses of global policy shocks. Of critical importance: major energy exporters save windfall gains and draw down savings when revenues are low – this is the primary risk reduction strategy already employed, allowing a relatively smooth government expenditure trajectory.

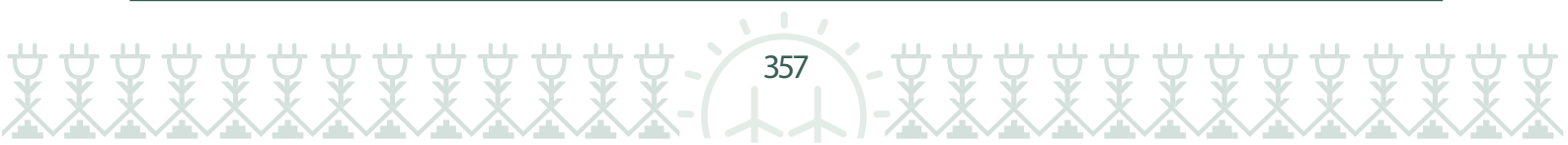
The proper metric to use to evaluate risk reduction is the variability of return on a capital investment. Renewables are extremely capital intensive, but what renewable output displaces is not just "fuel" for an exporter but the capital investment needed to maintain/create the capacity to produce said fuel. The key questions are: how much oil capital is displaced by a \$1 billion investment in solar & wind? How variable is the return to oil capital – given a variety of different potential oil market scenarios? How variable is the return to renewable generation capital and how correlated is the variability with that of oil capital? In this study, the return to the capital investments – as these are large scale investments to be undertaken by or incentivized by national governments – is welfare per \$ as opposed to profit.

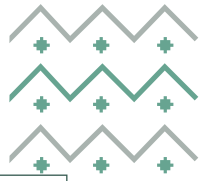
### Methods

We employ a global multi-regional computable general equilibrium model with a social accounting matrix derived from the EORA MRIO, with several aggregate regions including the EU and the GCC. A baseline model and two counterfactuals in which the GCC region sees an exogenous increase of \$1 billion in renewable electricity generation capital and an offsetting reduction (representing disinvestment) in fossil fuel electricity generation capital and associated extraction capital. In first counterfactual, the reduction in fossil fuel generation and extraction capital is equal to exactly \$1 billion. In the second counterfactual, the reduction in fossil fuel generation and extraction capital is sufficient to exactly offset the additional renewable electricity generated. The baseline and counterfactual models are then shocked by 10%, 20% and 30% increases and 10%, 20% and 30% decreases in global oil and gas demand. Model results obtained include the impact of shocks on employment, welfare and public finances as well as a comparison of the elasticity of these variables with respect to global oil and gas demand between the baseline and counterfactual models.

### Results

While in both models, employment, welfare and public finances respond strongly to shocks to global oil and gas demand this responsiveness is somewhat lessened by the addition to the model of a sovereign wealth fund holding assets abroad. Fossil fuels allocation between domestic and export markets varies with market conditions in both the baseline and the counterfactual models. However, the counterfactual model has a substantially lower share of fossil fuels in domestic electricity generation in the GCC region and as a result more limited scope for reallocating energy to the domestic market when global demand is low and to the export market when global demand is high. As a result, domestic electricity prices (assuming competitive market clearing equilibrium prices) fall more with low global oil and gas demand and rise more with high global oil and gas demand in the baseline model than in the counterfactual





model. Although electricity prices are more stable in the counterfactual model, since they are counter-cyclical in the baseline model this stability does not contribute to a strategy to reduce economic variability or risk associated with energy investments. Welfare, employment and tax revenue are found to be slightly less responsive to shocks to global oil and gas demand in the baseline model – without additional investment in renewable electricity generation – than in the counterfactual model. However, the counterfactual models represent a modest overall economic stimulus due to the lower overall levelized cost of electricity generation from renewable sources and result in larger contributions to sovereign wealth funds when global oil and gas demand are high than in the baseline model. There is less drawdown of oil and gas reserves overall in the counterfactual models than in the baseline model

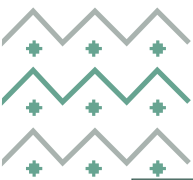
## Conclusions

While we do not state that investment in domestic renewable electricity generation capacity is unwise for energy exporters such as the countries of the GCC, this simulation-based analysis does not find evidence that it reduces the economic uncertainty resulting from fluctuations in global oil and gas demand. Within the assumptions of the model, justification for investment in renewables is found in the overall economic stimulus effect while any reduction in risk or uncertainty occurs only via the channel of the sovereign wealth fund. Certain limitations of the model and study include the assumption of perfect competition in both domestic electricity markets and the global oil and gas markets. Accurate representation of the geopolitical aspects of oil supply decisions is difficult if not impossible and possibly relevant for estimation of the impacts of the shocks within these models. The model is also unable to properly capture the role of oil and gas reserves in supply responses.

## References

- Lee, Duk Hee, et al. "Effects of energy diversification policy against crude oil price fluctuations." *Energy Sources, Part B: Economics, Planning, and Policy* 12.2 (2017): 166-171.
- Gozgor, Giray and Sudharshan Reddy Paramati. "Does energy diversification cause an economic slowdown? Evidence from a newly constructed energy diversification index." *Energy Economics* 109 (2022): 105970.
- Lesbirel, S. Hayden. "Diversification and energy security risks: the Japanese case." *Japanese Journal of Political Science* 5.1 (2004): 1-22.
- Shehabi, Manal. "Diversification effects of energy subsidy reform in oil exporters: Illustrations from Kuwait." *Energy Policy* 138 (2020): 110966.
- Atalay, Yasemin, Frank Biermann, and Agni Kalfagianni. "Adoption of renewable energy technologies in oil-rich countries: Explaining policy variation in the Gulf Cooperation Council states." *Renewable Energy* 85 (2016): 206-214.
- Darwish, Saad, Hafez Abdo, and Wael Mohammad AlShuwaiee. "Opportunities, challenges and risks of transition into renewable energy: the case of the Arab Gulf Cooperation Council." *International Energy Journal* 18.4 (2018).
- Bhutto, Abdul Waheed, et al. "A review of progress in renewable energy implementation in the Gulf Cooperation Council countries." *Journal of Cleaner Production* 71 (2014): 168-180.
- Almasri, Radwan A., and S. Narayan. "A recent review of energy efficiency and renewable energy in the Gulf Cooperation Council (GCC) region." *International Journal of Green Energy* 18.14 (2021): 1441-1468.





## *Economic impacts of renewable energy in Egypt by using a CGE model*

Tarek Safwat Kabel, Department of Economics, University of Sadat City, Egypt, [t.safwat14@hotmail.com](mailto:t.safwat14@hotmail.com)

Mohga Bassim, Department of Economics and International Studies, University of Buckingham, UK, [mohga.bassim@buckingham.ac.uk](mailto:mohga.bassim@buckingham.ac.uk)

### **Overview**

This paper aims to assess the economic effects of increasing renewable energy share in Egypt's electricity generation by using the Computable General Equilibrium (CGE) modelling. Using the CGE model, we have studied the impact of expanding the use of renewable energy in electricity generation on a number of economic variables (sectoral output, commodity prices, welfare, factor market, trade, macroeconomic variables, and GDP). We used a single country, multi-sector static CGE model to test the macroeconomic and sectoral impacts of three policy instruments that support renewable energy deployment under three scenarios that simulate renewable energy targets.

We simulate renewable energy targets in three scenarios that assume that the share of renewable energy in electricity generation is 20%, 42%, 53%, respectively, in addition to the base scenario, which assumes that the share of renewable energy in electricity generation will remain 10% as it was in the base year in the absence of renewable energy policies. In order to support the deployment of renewable energy, we assume that the increase is achieved through three policy instruments. These policies are: 1) introducing tax incentive policy by imposing a tax exemption for electricity generated from renewable energy, 2) introducing Renewable energy subsidy (RES), and 3) introducing the Renewable Portfolio Standard (RPS) policy by assuming that it is financed by increasing the price of electricity generated by fossil fuels.

The simulation shows that an increase in the share of renewable energy in electricity generation results in an increase in GDP under all policies in all scenarios, except under the tax incentive policy when the share of renewable energy in electricity generation reaches 20%. Although the RPS policy reduces household consumption, the subsidy and tax incentive policies increase household consumption. The study concludes that the expansion in the use of renewable energy in electricity generation positively impacts the Egyptian economy, but the degree of impact varies according to the policy used.

### **Methods**

This study relies on the Computable General Equilibrium modelling. We used a single country, multi-sector static CGE model to test the macroeconomic and sectoral impacts of three policy instruments that support renewable energy deployment under three scenarios that simulate renewable energy targets. As is customary in the Computable General Equilibrium model, Social Accounting Matrix is the core data for the model. Our CGE model is based on Egypt Social Accounting Matrix 2014/2015 constructed by the CAPMAS (CAPMAS, 2019a). The standard SAM contains a single account for the electricity sector and is not suitable for this study's main objective, which is related to assessing the economic impacts of an increasing share of renewable energy in generating electricity. For this reason, we modified the standard SAM by disaggregating the electricity sector into different subsectors based on its electricity generation technologies.

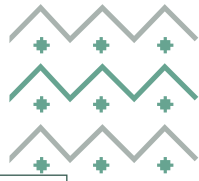
### **Results**

The simulation results show that increasing the share of renewable energy in electricity generation positively impacts the GDP, whether the policy used is a tax incentive, subsidy, or RPS. This positive impact is except that the expansion of the use of renewable energy in electricity generation to 20% using the tax incentive negative impact on the GDP due to the decrease in investments and government consumption. The positive impact of expanding the use of renewable energy in electricity generation on GDP is due to the resulting increase in household consumption, government consumption, and investment. Compared to tax incentive and subsidy policies, the RPS policy has a more significant positive impact on the GDP.

In terms of sectoral level, the impact of expanding the use of renewable energy in electricity generation varies according to the type of policy used to encourage the deployment of renewable energy. The effect also varies by sector. The tax incentive policy increased the volume of production in most sectors, while the subsidy and RPS policies reduced production volume in most sectors. For example, the volume of production decreased in the petroleum-







intensive sectors under the subsidy policy, as the subsidy policy was financed through taxes on petroleum products. In the same context, the volume of production of fossil fuel products decreased under the RPS policy due to the decrease in electricity demand for fossil fuel products.

## Conclusions

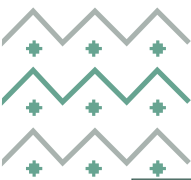
We apply the static CGE model to assess the economic effects of increasing the share of renewable energy in electricity generation in Egypt. We have a baseline scenario that assumes that the share of renewable energy in electricity generation will remain 10% of the total generated electricity as it was in the base year 2014, in the absence of renewable energy encouraging policies (instruments). The other three scenarios assume that the share of renewable energy in electricity generation increased to 20%, 42%, and 53%, respectively. We modelled three policy instruments in this paper: tax incentive, renewable energy subsidy, and renewable portfolio standard (RPS). We describe the impacts of these simulations on different economic variables, including sectoral output, commodity prices, welfare, factor market, trade, macroeconomic variables, and GDP. We can summarise that our results indicated that increasing the share of renewable energy in electricity generation positively affects most economic variables. However, the scale of these impacts varies depending on the policy used to support renewable energy deployment.

By comparing the economic effects of the three policy instruments, we found that although the RPS policy has a negative impact on the welfare variables, as it led to a decrease in household income, household consumption, and household savings, it is more efficient than the tax incentive and subsidy policies. This higher effectiveness is because of its positive impact is more significant on the GDP, government income and the reduction of imports. For example, the RPS policy led to an increase in GDP by LE 4.91 billion when the share of renewable energy was increased to 42%. The RPS policy is borne by the consumer more, while the government does not bear any costs in this policy. Our simulation results conclude that the expansion in use of renewable energy in electricity generation has a positive impact on the Egyptian economy, but the degree of impact varies according to the policy used.

## References

- Black, J., Borbely, D., Figus, G., Roy, G. and Spowage, M., 2019. *Feasibility Study on Developing Trade Modelling for Scotland*. Glasgow.
- Mcdonald, S., 2007. A Static Applied General Equilibrium Model : Technical Documentation DRAFT. (July), pp.1–81.
- Acar, S., Voyvoda, E. and Yeldan, E., 2018. Modeling for green growth: environmental policy in a dualistic peripheral economy. In: *Macroeconomics of climate change in a dualistic economy: a regional general equilibrium analysis*. Academic Press, pp.93–116.
- Central Agency for Public Mobilization and Statistics, 2019a. First Regionalized Social Accounting Matrix for Egypt A 2015 Nexus Project Social Accounting. CAPMAS, Cairo
- International Renewable Energy Agency, 2018a. *Renewable Energy Outlook: Egypt*. IRENA, Abu Dhabi. Available at: <https://www.irena.org/publications/2018/Oct/Renewable-Energy-Outlook-Egypt>
- New & Renewable Energy Authority, 2021a. *New & Renewable Energy Authority- Annual Report*. NREA, Cairo.
- Osman, R., Ferrari, E. and Mcdonald, S., 2019. Is Improving Nile Water Quality 'Fruitful'? *Ecological Economics*, 161, pp.20–31.
- Tabatabaei, S.M., Hadian, E., Marzban, H. and Zibaei, M., 2017. Economic, welfare and environmental impact of feed-in tariff policy: A case study in Iran. *Energy Policy*, 102, pp.164–169.





## ***VIRTUAL POWER PLANT: A SMART WAY OF MANAGING SOLAR SYSTEMS***

Zahid Ullah, Institute for globally distributed open research and education, UK, [Zahid.ullah@igdore.org](mailto:Zahid.ullah@igdore.org)  
Arshad, Glasgow Caledonian University, Glasgow, UK, [Arshad.arshad@gcu.ac.uk](mailto:Arshad.arshad@gcu.ac.uk)  
Muhammad Ali, University of Glasgow, UK, [Muhammad.ali@glasgow.ac.uk](mailto:Muhammad.ali@glasgow.ac.uk)

### **Abstract**

The aim of this study is to address operational framework problems in electric power systems that are made up of solar systems, dispatchable load (DL), and power demand. The performance of a solar system with a dispatchable load within a virtual power plant (VPP) is studied. The method determines the level of solar system reliability in electric power systems. The proposed approach utilized historical data from renewable energy sources (RESs), primarily solar power systems, and dispatchable load to predict the amount of power that could be supplied and compare it to the amount of power needed to find any discrepancies in power supply and demand. The usefulness of the proposed approach is demonstrated by the implementation of linear programming in a case study of a typical power system problem under the VPP setting. The preliminary results suggest that rational VPP management practices have been developed, and these solutions can be used to mitigate the solar system's inherent uncertainty and maximize supply reliability. The results will assist decision-makers to come up with alternatives in case of power supply shortage, as well as system operators in determining the proportion of generation that solar systems can deliver.

### **A. Background and motivation**

Due to population growth, industrialization, technological advancement, and urbanization, power demand has risen across the globe in recent years. Sustainable growth will be encouraged by the demand for cleaner, more environmentally friendly energy to meet the world's growing energy needs [1,2,3]. One possible solution to meet this rising energy need is to harness renewable energy sources (RESs), especially solar power systems. Sunlight provides more than enough power for humanity, and no one can control and monopolize its supply. Moreover, using the solar system is a cleaner, safest, and simpler way to support a sustainable future [4,5]. Solar power plants have gained popularity as a result of technological development and falling generation costs. Therefore, it is imperative to make the transition to a more sustainable system of energy. It is because of environmental concerns and the need for clean energy [6]. The main benefit of RESs is that they do not directly contribute to environmental carbonization and do not promote global warming. However, the adoption of RESs causes challenges in the operation of the distribution grid, which affects the power quality. Therefore, their integration into conventional power systems is highly problematic due to their stochastic and uncertain nature. Innovative measures are, therefore, necessary to enable the migration from a conventional system to a smart energy system in regard to sustainable energy in a cost-effective manner [7,8]. To overcome these challenges, we put forward the idea of a virtual power plant (VPP) as a possible option. That combines the generation capacities of a large number of small distributed energy resources (DERs), dispatchable loads (DLs), and power demand as a market entity to efficiently offer scalable, reliable, and sustainable energy to end users, as well as provide market access to small generators to generate revenue and minimize the inherently uncertain nature of solar systems.

### **B. Aim, Objective, and Approach**

The aim of this study is to design and develop a new market mechanism for a VPP operating in a market environment. This mechanism accommodates smaller generators to access the day-ahead electricity market under the auspices of the VPP and generates income for them. For the market under study, a centralized control (CCM) mechanism is proposed. The proposed mechanism was used to conduct an experimental verification of its efficacy. In essence, it means that the VPP controller has the most control over each DER, and dispatchable loads while the performance of the system as a whole is improved with the proposed CCM.

The components of the VPP are coordinated through the application of smart information and communication technologies (ICTs) so that they can operate as a unified market entity, even though they are not geographically co-located. The VPP might have either a centralized or decentralized control strategy. The centralized control system of VPP is based on a sole centralized control system, that does not need to be physically installed at any of the monitored sites. The centralized VPP controller decides which power-producing unit and dispatchable loads will be deployed in order to maximize the energy production from the portfolio assets. The predicted portfolio assets generation, the availability of dispatchable loads, and market prices are all calculated by the VPP's centralized control system using historical data and then command signals are sent to the local controllers to



satisfy that demand. In this setup, the VPP allows for bidirectional communication between the local controller and the centralized VPP controller. The cost of dispatchable loads being curtailed is periodically transmitted by the local controller. Based on field data collection, the centralized VPP controller sends the required time slots with market prices to the local controller. Fig 1 shows the design of the proposed VPP market structure and information flow between the local and centralized VPP controller as well as interaction of the centralized VPP controller with the main grid.

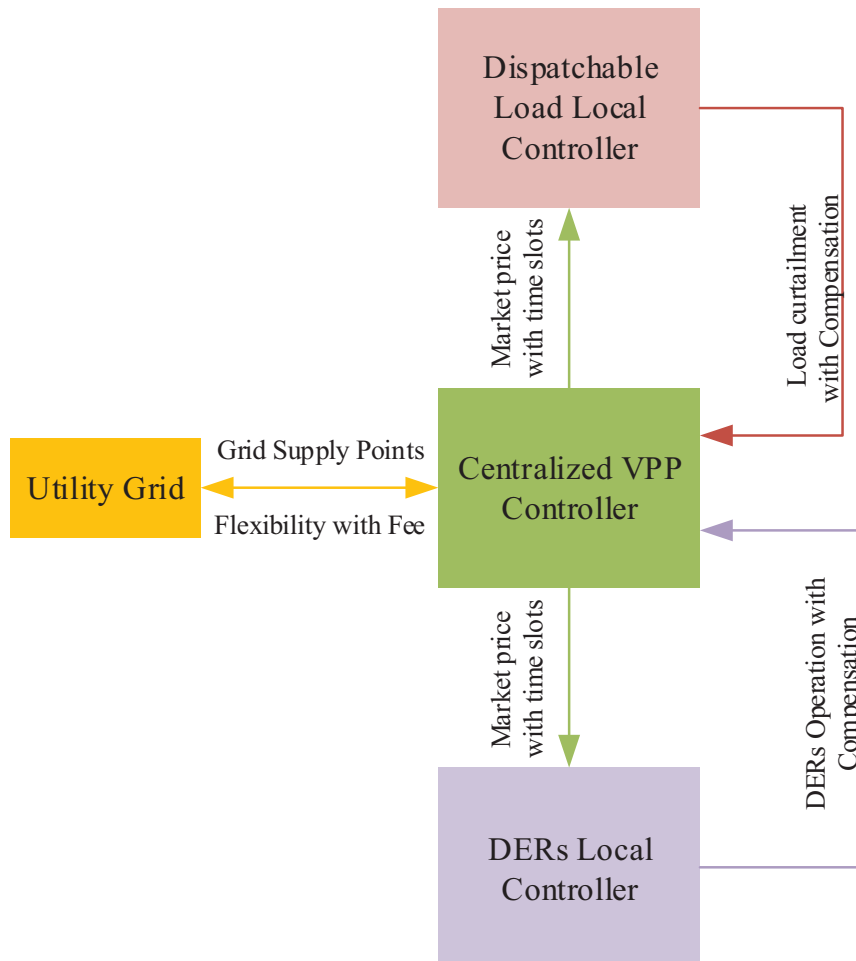


Fig 1 Proposed VPP market structure

### C. Mathematical modeling

The main objective of the algorithm is to generate revenue for participating members and minimize the inherent uncertainty of the solar system while considering the constraints of the system. The consumer benefit function is  $(\lambda_{(it)}^{Curt} Load_{(it)}^{Curt})$  added to the objective function to reflect customer behaviours in response to price change.

$$Max\ profit \left[ \sum_t \sum_i (\lambda_{(it)}^{Demand} P_{(it)}^{Demand}) - \sum_t \sum_i (P_{(it)}^{PV} Cost_{(it)}^{PV}) - \sum_t \sum_i (\lambda_{(it)}^{Curt} Load_{(it)}^{Curt}) \right] \quad (1)$$

The first term of the objective function represents the power demand with a corresponding cost at each bus  $i$  and time  $t$ . The second term represents the solar system's active power generation with its related cost, while the load curtailment with a compensation fee is represented by the third term at each bus  $i$  and time  $t$ .

$$P_{(it)}^{PV} = \frac{R(t)}{G} \cdot P_{ratee}^{PV} \cdot \eta^{PV} \quad (2)$$

The power supplied by each PV panel in each bus  $i$  at any given time  $t$  can be stated mathematically as [2], where  $R(t)$  represents the solar insolation measured in kilowatts per meter square at time  $t$ . The rated power of each solar panel is represented by  $P_{rated}^{PV}$ , the efficiency of the PV module is represented by  $\eta^{PV}$ . Solar irradiance is represented by  $G$  in watt per meter square and the power is measured in kilowatt.

$$Cost_{(it)}^{Curt} = \sum_t \sum_i (\lambda_{(it)}^{Curt} Load_{(it)}^{Curt}) \quad (3)$$

The load curtailment compensation fee is represented by equation (3), Where  $Cost_{(it)}^{Curt}$  is the total sum of compensation fees paid to consumers by the VPP while reducing load demands. The compensation fee for curtailment at each bus  $i$  and time  $t$  is represented by  $\lambda_{(it)}^{Curt}$ . The quantity of load curtailed at each bus  $i$  and time  $t$  is represented by  $Load_{(it)}^{Curt}$ . According to the extent of the load curtailment, different levels of curtailment have different effects on consumers. As a result, consumers receive compensation fees for load curtailment based on the magnitude of the load reduction.

#### D. Case study, simulation results, and discussions

The centralized VPP control mechanism for the energy market is supported by preliminary simulation results from a case study using a 16-busbar, UK generic distribution system (UKGDS). We supposed that buses 3, 6, 11, and 12 were outfitted with four PVs. It is also supposed that the PVs have a 0.95 lagging power factor. It is supposed that each candidate bus can have only one PV assigned. PVs with a cumulative capacity of 440 kW have been installed on their designated buses.  $V_{min} = 0.94$  p.u and  $V_{max} = 1.06$  p.u, are the min/max voltage limits. The planning horizon used in this study is a day divided into 24 hours. All the necessary data is taken from reference [9] with some modifications to fit our purpose.

Fig 3 shows the dispatchable load curtailment value over the planning horizon for each hour. Hour 12 has the highest load curtailment value, which is around (6kW). This is because the dispatchable loads are being offered the maximum market price at this hour. In comparison, hour 6 has the least value, which is approximately 0.1kW. This is because the lowest market pricing for the dispatchable load is available at this hour. The specified generator obligations at Buses 3, 6, 11, and 12 are shown in Fig 4. Fig 2 shows the location of Bus 3 as the system's least expensive generator. Therefore, this generator is operated at its full capacity to meet the needs of the load as shown in Fig 4. While the most expensive generator of the system is located at bus 12 as shown in Fig 2, therefore, the least amount of this generator is used to meet the needs of the load.

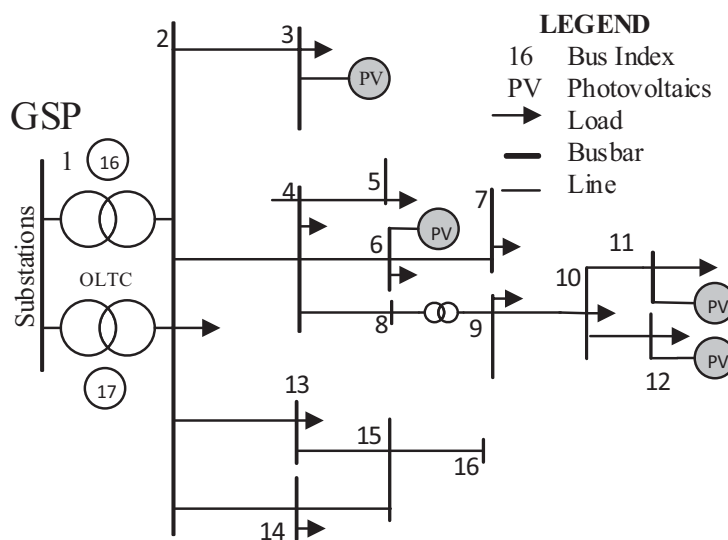


Fig 2 Single line diagram of 16-bus UKGDS

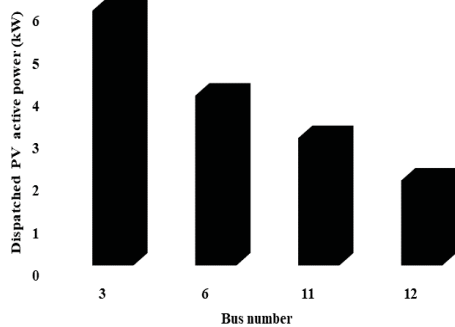
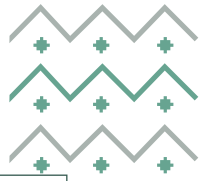


Fig 4 PV dispatched active power

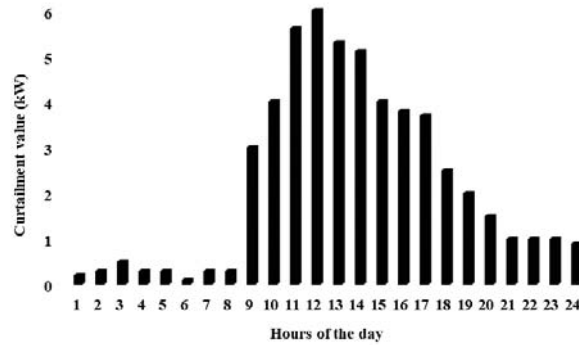


Fig 3 Dispatchable load curtailment

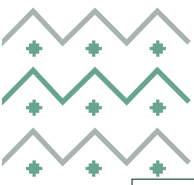
### E. Conclusions

in this study, we addressed the operational problem of an electric power system under the VPP setting. The electric system composed of load demand, solar system, and dispatchable loads operating in the day-ahead electricity market to minimize the inherent uncertain nature of the solar system and generate revenue for the participating members. The simulation studies were carried out on a 16-busbar UKGDS. The preliminary results confirm the benefits and efficacy of the proposed approach. Initial findings show that the dispatchable load's contribution considerably minimizes the internal load of the VPP and effectively addresses the solar system's uncertainty. The simulation results demonstrated the impact of load reductions on the profit of energy producers. Also, introducing dispatchable loads into the formulation has the potential significance of preventing price spikes and ensuring improved pricing consistency, particularly in the case of power demand during peak hours. As part of our future work plan, we will integrate energy storage system technologies and will investigate how they might affect the solar system and the welfare of VPPs.

### References

1. Badar, A. Q., Patil, P., & Sanjari, M. J. (2022). Introduction and history of virtual power plants with experimental examples. In *Scheduling and Operation of Virtual Power Plants* (pp. 1-26). Elsevier.
2. Poplawski, T., Dudzik, S., Szeląg, P., & Baran, J. (2021). A Case Study of a Virtual Power Plant (VPP) as a Data Acquisition Tool for PV Energy Forecasting. *Energies*, 14(19), 6200.
3. Nosratabadi, S. M., Hooshmand, R. A., & Gholipour, E. (2017). A comprehensive review on microgrid and virtual power plant concepts employed for distributed energy resources scheduling in power systems. *Renewable and Sustainable Energy Reviews*, 67, 341-363.
4. Ullah, Z., & Hassanin, H. (2022). Modeling, optimization, and analysis of a virtual power plant demand response mechanism for the internal electricity market considering the uncertainty of renewable energy sources. *Energies*, 15(14), 5296.
5. Panda, S., Mohanty, S., Rout, P. K., & Sahu, B. K. (2022). A conceptual review on transformation of micro-grid to virtual power plant: Issues, modeling, solutions, and future prospects. *International Journal of Energy Research*, 46(6), 7021-7054.
6. Marinescu, B., Gomis-Bellmunt, O., Dörfler, F., Schulte, H., & Sigrist, L. (2022). Dynamic virtual power plant: A new concept for grid integration of renewable energy sources. *IEEE Access*, 10, 104980-104995.
7. Mishra, S., Bordin, C., Leinakse, M., Wen, F., Howlett, R. J., & Palu, I. (2022). Virtual Power Plants and Integrated Energy System: Current Status and Future Prospects. *Handbook of Smart Energy Systems*, 1-31.
8. Rouzbahani, H. M., Karimipour, H., & Lei, L. (2021). A review on virtual power plant for energy management. *Sustainable energy technologies and assessments*, 47, 101370.
9. Ullah, Z., Mirjat, N. H., & Baseer, M. (2022). Optimisation and Management of Virtual Power Plants Energy Mix Trading Model. *International Journal of Renewable Energy Development*, 11(1).





## ESG and Corporate Financial Performance in Emerging Markets - a U-shaped relationship?

Alexander Schult

December 2, 2022

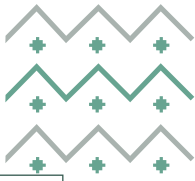
---

### Abstract

Sustainability, nowadays often summarized as ESG, is one of the most pressing topics for this planet. While the relationship between ESG and Corporate Financial Performance (CFP) is widely studied in developed markets, the field for emerging markets remains comparably scarce and produces contradictory results between ESG and CFP. One reason for this inconclusive picture might be the underlying assumption of a linear relationship between ESG and CFP in prior studies. This assumption, however, neglects the potential of an actual curvilinear relationship that could explain the negative and positive linear findings for emerging markets. This study contributes to the ESG-CFP literature in emerging markets by examining whether the relationship between ESG and CFP follows a curvilinear U-shape for up to 2,200 firms from 27 emerging markets for the time frame 2002-2019. While the results for linear estimations point towards a positive relationship between ESG and CFP in the first place, curvilinear estimations suggest a U-shaped relationship between ESG and CFP for accounting-based metrics, but not for market-based metrics. Instead, the results for market-based CFP metrics indicate a positive linear association in emerging markets. One reason could be that sustainability efforts come at costs that are negatively reflected in accounting metrics but positively rewarded in market-performance metrics in the anticipation of upcoming relevance and regulation of sustainability in emerging markets. This study is one of the very first to examine the shape of the ESG-CFP relationship for emerging markets. Further research should extend the knowledge about the ESG-CFP relationship in emerging markets.

*Contact details:* alexander.schult@tum.de; Technical University of Munich, TUM School of Management, Chair of Management Accounting, Arcisstraße 21, 81675 Munich





## Analytical and prospective study of the Turkish experience in the field of renewable energy investments

[Abdelmalek Mahri, economy, +213 6 96 24 26 01, [Abdelmalek.Mahri@univ-tebessa.dz](mailto:Abdelmalek.Mahri@univ-tebessa.dz)]

[Abdelmalek Meriem, economy, +213 6 69 58 41 29, [abdelmalekmeriem01@gmail.com](mailto:abdelmalekmeriem01@gmail.com)]

[Laib Sana, economy, +213 6 65 33 47 73, [laibsana89@gmail.com](mailto:laibsana89@gmail.com)]

### Overview

This paper comes to search in the problem of renewable energy investments of the Turkish government's experience, because the energy vision in Turkey is based on the security of energy supplies, the diversity of its resources and alternative energy resources, and the use of local energy resources to create an added value in the economy, and the liberalization of energy markets. And their efficiency, on the other hand, is all this a motive that made the Turkish government attach importance to increasing the share of renewable sources in the country's total installed energy to 30% by 2023.

Renewable energy has been one of the important topics in Turkey's energy agenda, and the Turkish government has made important reforms in this field during the past decade, after enacting the Law on the Use of Renewable Energy Resources for the Purpose of Electricity Generation (Renewable Energy Law) in 2005. Several updates have been made. Laws and regulations. As a result, Turkey's energy sector has turned into one of the world's most attractive investment destinations. In line with the implementation of investor-friendly regulations and the significant increase in demand, the Turkish energy sector is becoming more vibrant and attracting more investors' attention to each component of the value chain in all energy sub-sectors.

### Methods

The research depends on the analytical descriptive method, with the aim of studying the scientific phenomenon related to: "The Turkish experience in the field of renewable energy investments", this study was also supported by a case study from the reality represented in the Turkish experience, which is considered good in the field of alternative energies through various government programs and plans that have contributed to a relatively successful degree in getting this country out of the tunnel of traditional energies into the light of alternative renewable energy.

### Results

- Turkey uses energy sources inefficiently and consumes more energy to produce products;
- The demand for energy in Turkey is constantly increasing, which necessitates providing energy to the largest possible number of the population, which is also constantly increasing;
- Hydroelectric power stations, the use of biomass for heating and the use of geothermal energy are major contributors in terms of renewable energy resources to the Turkish energy mix;

### Conclusions

Turkey has attached great importance to generating energy from renewable energy sources with the aim of diversifying its sources, reducing dependence on imports and emission of greenhouse gases, and developing the local manufacturing industry. However, this remains insignificant compared to the strength of its economy and its rapid growth, which requires greater demand for energy from its various sources.

### References

- <http://www.invest.gov.tr/ar-SA/investmentguide/investorsguide/Pages/MacroEconomicIndicators.aspx>
- <https://wonderopolis.org/wonder/where-in-the-world-is-turkey>
- <http://www.turkstat.gov.tr/HbGetirHTML.do?id=24638>
- Derya Kaplan, Renewable Energy Turkey, Ankara, October 2020.
- International Renewable Energy Agency (IRENA), Renewable Energy Statistics 2016, Abu Dhabi, 2017.
- International Energy Agency (IEA), Energy Policies of IEA countries Turkey 2019 Review, Paris-France, 2019..
- <http://www.invest.gov.tr/ar-SA/sectors/Pages/Energy.aspx>.
- Derya Kaplan, Renewable Energy Turkey, Ankara, October 2020.



## ASSESSMENT OF PRICE POLICIES IN THE POWER MATRIX OF SAUDI ARABIA UNDER THE SCOPE OF VISION 2030

Harif D. Fontecha, King Abdullah University of Science and Technology, 966 56 5457598, harif.fontechasanchez@kaust.edu.sa  
Shashank Nagaraja, King Abdullah University of Science and Technology, 353 89 9544184,  
shashank.sakleshpurnagaraja@kaust.edu.sa

[Mani Sarathy, King Abdullah University of Science and Technology, 966 54 4700556, mani.sarathy@kaust.edu.sa]

### Overview

Environmental and economic impacts are often seen as two disparate forces in the energy sector. For instance, more environmentally friendly alternatives tend to have an economic disadvantage and vice versa. Nevertheless, a selection of strategies has also demonstrated that environment and economics can coexist and in synergy. Such strategies are highly dependent on the policies and resources of each country. Hence, the goal of this work is to evaluate how different pricing policies affect the demand of electricity, as well as how they affect how much renewable energy should be used in an optimized grid mix by 2030.

By 2030, in a scenario free of reforms, liquid fuels would provide more than half of the fuel energy consumed for generation and would emit around 64% of the emissions. However, they would only represent 10% of the fuel costs at a domestic price.

In this work, the effect and pertinence of reforms to the electricity price and to the fuels consumed for generation are addressed. Tariffs for countries with similar size of economy are taken as a reference.

1. To elaborate a techno-economic evaluation of the status of the Saudi electricity grid mix and its associated greenhouse gas emissions.
2. To forecast the demand of electricity of Kingdom of Saudi Arabia by 2030, considering the effect of global warming and comparing the potential impact of changes in the price policies of electricity.
3. To calculate the optimized power mix needed by 2030 to supply for each demand scenario under the methodology of Capacity Expansion Planning.

The Capacity Expansion Planning (CEP) scenarios are as using the software PLEXOS and the optimization is done using CPLEX which works under.

### Methods

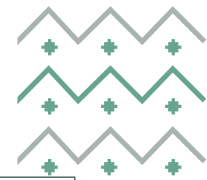
We divide the Kingdom into 4 areas, adhering to the National Grid's boundaries through 2019. The demand scenarios were constructed using a variety of econometric models developed by KAPSARC, taking into account the impact of factors including weather, GDP per capita, power price, and population increase.

The weather variable was quantified using the concept of *Cooling Degree Days* and *Heating Degree Days*, which is an indicator of the amount of energy required for cooling and heating, respectively, each year. Plotting historical data reveals a rising tendency. Despite the variability of the weather data, particularly in recent years, a linear model was used to project the future rate of climate change.

Three scenarios were defined based on the intentions of the Ministry of Energy to increase private participation in the national power market. For that, electricity prices were modified and the corresponding demand response is calculated. The scenarios are defined as follows:

1. Business As Usual Case (BAU): The current tariff of electricity remains untouched.
2. Transitional Case (TRN): The tariff of electricity for the residential, governmental and commercial sectors increases by 100% by 2030, with a 50% increase in 2023 and the other 50% increase in 2028. The tariff of electricity for the industrial and agricultural sector is increased by 44% in 2025 to reach international levels.
3. International Tariff Case (INT): The tariff of electricity for the residential, governmental and commercial sectors increases by 200% by 2030 to reach international equivalent values, with a 100% increase in 2023





and the other 100% increase in 2028. As well as in the Transitional Case, the tariff of electricity for the industrial and agricultural sector is increased by 44% in 2025 to reach international levels.

Afterwards, Capacity Expansion Planning (CEP) cases were optimized for each of the four regions, from 2022 to 2030. The optimization of the scenarios was done using Mixed Integer Linear Programming. Historical electricity demand and the distribution of generation per technology was taken from WERA public yearly reports and its official website. The technologies considered are gas turbines, steam turbines, combined cycle, cogeneration, diesel engines, PV, wind and nuclear energy. The historical distribution of fuel used for electricity (considering Crude Oil, HFO-380, HFO 180, Diesel and Gas) was taken from WERA public yearly reports and publications from KAPSARC.

Wind characteristic profiles were taken from the *Global Wind Atlas* web page and solar characteristic profiles were taken from the European Commission's PVGIS maps. The efficiencies of existing turbines were established according to datasheets of General Electric and the efficiencies of new turbines were assumed to be as those of the GE H-Frame turbine.

Typical Wind Turbine Output profiles were taken from NRELs System Advisor Model using the Vestas Turbine Model V150/4000-4200 as reference. This turbine reference has already been used in the Kingdom, more specifically in the Al Jubail project. Typical Solar Efficiencies were taken from the NRELs System Advisor Model.

Fixed and variable costs of each technology/fuel combination considered after filtration were defined based on the IAE Report: "Projected Costs of Generating Electricity" 2020 Edition.

### Results

The characteristic regional differences in demand response were addressed. The demand per capita is the largest in the eastern region, followed by the central, west and south regions, in that order. Diverse authors have addressed this to the income level of each region, as well as the inherent existing infrastructure.

The eastern region has shown to be more sensitive to changes in the electricity price, which can elucidate the space for improvements in energy efficiency through awareness programs. In contrast, the demand of the western region is the most sensitive to income variations. As expected by its milder weather conditions, the southern region is the least sensitive to anomalous fluctuations of hot weather. Cold weather, in contrast affects only the demand of the southern and central regions, where temperatures in the winter can reach temperatures below 10°C.

When computing the three electricity pricing scenarios, it was found that the demand for the TRN case is 6.4% lower than the BAU case. Additionally, the demand of the INT case is in total 9% lower than in the BAU case.

We found that raising the electricity price to international tariffs could reduce the demand projections for 2030 by up to 9%. Being the industrial sector more sensitive to price changes than the residential sector.

The distortion between fuel price and consumption could be adjusted by increasing the domestic fuel prices to 30% of the international reference, which affects mainly liquid fuels. In this scenario, photovoltaic panels (PV) become a competitive substitute for gas turbines (GT). However, renewables would not exceed 43% of the total capacity and 28% of the energy generated without the early retirement of firm capacity. The resulting cost of emissions avoided by reforming fuel prices is of \$43/ton CO<sub>2</sub>eq.

Simultaneously reforming electricity prices and fuel prices would favor the penetration of renewables without additional costs of investment. Besides, the marginal cost of electricity would remain close to \$45/MWh.

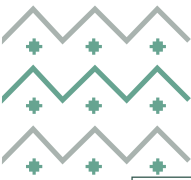
Finally, reforming the price of fuel and exporting the saved fuel would derive in additional revenue of up to \$6.6 billion by 2030, and would reduce the annual emissions by 2030 by up to 66 million tons of carbon dioxide. The economic gain from exporting the fuel saved by 2030 would be enough to relieve the additional cost in the electricity bill to the residents which represent 73% of the total consumption, through social programs.

### Conclusions

Reducing the demand through electricity price reforms has been effective so far. However, further increments in the price will be considerably less impactfull in the demand. Increasing the electricity tariffs towards international prices (INT case) reduces the demand 9% contrasted with the BAU case. Around 70% of the same impact can be effected by a, less aggressive, intermediate pricing policy change (TRC case), with a demand that is 6.4% lower than the BAU case. Social awareness campaigns and the installation of smart meters are examples of additional strategies that do no affect economically the users and can be more effective.

Combined cycle gas turbines (CCGT) remains as the most efficient and cheapest technology available if no price reforms are levied (REF). In this scenario, the limited access to gas in the southern region forces the installation of





new gas turbines (GT). The potential for wind turbine (WT) projects is limited in the Kingdom. Only 5 GW of WT in the windiest part of the western region (NEOM) is economically competitive.

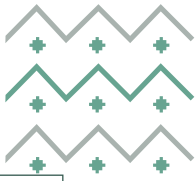
In a scenario free of reforms (REF), liquid fuels would provide more than half of the fuel energy consumed for generation, and would emit around 64% of the emissions by 2030. However, they would only represent 10% of the fuel costs at a domestic price. This distortion could be adjusted with an adjustment to the domestic fuel prices to 30% of the international reference, which affects mainly liquid fuels. Under this scenario, photovoltaic panels (PV) become a competitive substitute for gas turbines (GT).

Even with a drastic reform, renewables would not exceed 43% of the total capacity and 28% of the energy generated. Additional shares of renewables would only be possible with the early retirement of existing firm capacity. The additional investment costs of the S30 reform would be 19% larger than the reference case (REF). Nevertheless, the reduction in demand caused by simultaneously levying an electricity price reform (S30-MID) would take the additional costs of investment to zero.

Reforming the price of fuels would reduce the annual emissions by 2030 by up to 66 million tons of carbon dioxide, or 12% of the annual emissions of the reform-free scenario (REF). Finally, the economic gain from exporting the fuel saved by 2030 would be enough to relieve the additional cost in the electricity bill to the residents which represent 73% of the total consumption through social programs.







## Ex-post assessment of energy price reforms in Saudi Arabia

Salaheddine Soummane  
King Abdullah Petroleum Studies and Research Center (KAPSARC)  
Email: salaheddine.soummane@kapsarc.org

### 1. Overview

Fast-growing energy uses in countries with regulated markets cause economic inefficiencies and environmental damages. To curb demand growth and contain these effects, governments can adjust prices through reforms. However, estimating the costs and benefits of reforms following their implementation to measure their effectiveness remains scarce. In this paper, we quantify the implications of energy price reforms in Saudi Arabia following the two waves of 2016 and 2018. We use a computable general equilibrium model calibrated to Saudi Arabia to assess the economic and environmental interplays of energy price reforms. We estimate the overall macroeconomic impact of energy price reforms at a yearly average gain of GDP of 0.5% between 2016 and 2019. While the reforms resulted in a negative impact on private consumption and household revenue, it was largely offset by the positive impact on government revenue through increased export revenue. Moreover, setting a compensation mechanism to mitigate the impact of price reforms on households limited the impact on private consumption while channelling the additional revenue into investment contributed to the macroeconomic improvement. Finally, we show the environmental gain from the energy price reforms policy. Between 2016 and 2019, reforming energy prices decreased annual carbon dioxide emissions by around 4% per year on average, corresponding to cumulative emissions cut of around 15% over this period.

### 2. Methods

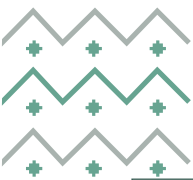
The IMACLIM model is an economy-wide model representing the supply and demand of goods and services, with the specific purpose of articulating with engineering representations of the energy system to produce consistent energy-economy-environment (3E) outlooks. In this paper, we employ the IMACLIM-SAU, a dynamic computable general equilibrium (CGE) model that embodies specific features of the Saudi economy (see Soummane et al., 2022, Soummane and Ghersi, 2022). The model covers 13 sectors, comprised of four energy sectors (crude oil, natural gas, refined products, and electricity) and nine non-energy sectors.

Our modeling framework allows for an in-depth assessment of energy price reform policies. The multi-sector framework with multi-energy sources and secondary income distribution is well-suited for quantifying the economic impact of energy policies. Our approach is based on two policy simulations. First, we run a Realized scenario in which administered energy prices are adjusted to reflect energy price reforms implemented in 2016 and 2018. Second, we simulate a Counterfactual scenario, in which we omit the price reforms plans, i.e., maintaining energy prices at their 2015 levels. The modeling approach allows for a three-level classification of the results, i.e., economic (in which we discuss the gross domestic product decomposition in addition to public and household revenue variation), energy (in which we present fuel variation and sectoral consumption), and emissions (capturing potential carbon dioxide variation across scenarios resulting from energy demand variation).

### 3. Results

#### 3.1 Macroeconomic outcomes





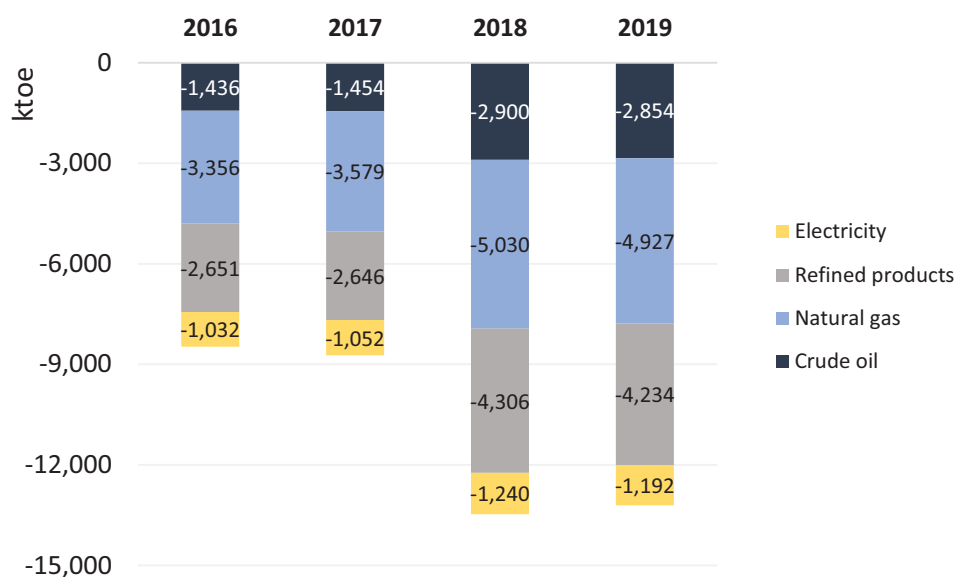
**Table 1.** Impact of energy price reform compared to the Counterfactual scenario, by economic aggregate.

	2016	2017	2018	2019
<b>Real GDP</b>	0.3%	0.3%	0.7%	0.7%
<b>Private consumption</b>	-0.2%	-0.1%	-2.4%	-2.3%
<b>Public consumption</b>	0.3%	0.4%	1.6%	1.6%
<b>Investment</b>	0.3%	0.3%	1.3%	1.3%
<b>Exports</b>	0.7%	0.7%	1.7%	1.7%
<b>Imports</b>	0.5%	0.6%	-0.3%	-0.3%
<b>Net government revenue</b>	-17.1%	-37.4%	25.2%	22.8%
<b>Households' revenue</b>	-0.7%	-0.7%	-1.3%	-1.1%
<b>Carbon dioxide emissions</b>	-2.8%	-2.8%	-4.8%	-4.7%

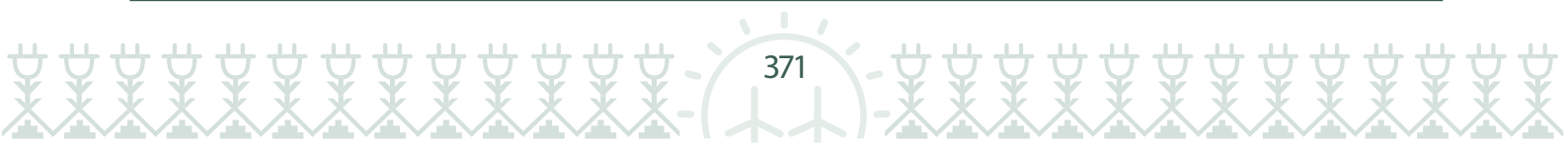
Source: Author's calculations based on IMACALIM-SAU simulations.

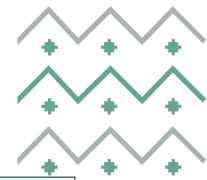
### 3.2 Energy demand outcomes

**Figure 1.** Impact of energy price reform compared to the Counterfactual scenario, by fuel.

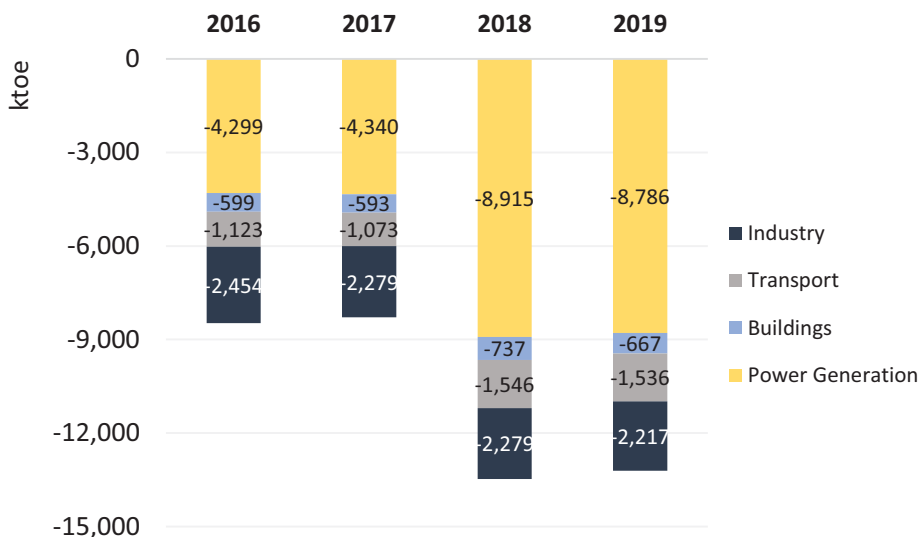


Source: Author's calculations based on IMACALIM-SAU simulations.





**Figure 2.** Impact of energy price reforms compared to the Counterfactual scenario, by sector.



Source: Author's calculations based on IMACALIM-SAU simulations.

### 3.3 Emissions outcomes

Yet to be finalized.

## Conclusions

This paper examines the effect of energy price reforms on the Saudi economy through the lens of a CGE model. Reforming energy prices in regions with administered tariffs could be an effective tool to curb fast-growing energy demand and carbon emissions in Middle East countries (Breton and Mirzapour, 2016). However, ex-post assessments of past policies are not widely presented (Aryanpur et al., 2022). This study provides new insights into the macroeconomic implications of energy price reforms. The overall outcome of energy price reforms shows a net positive impact on main macroeconomic indicators through an improvement in public revenue, investment, and exports. The observed negative impact on household income, resulting in decreasing private consumption, can be mitigated through direct transfers to selected households through recycling the additional revenue. Finally, a significant decrease in carbon dioxide emissions resulted from implemented price reform policies. Therefore, adjusting energy prices prove to be an effective policy in achieving Saudi climate policy targets. Our results inform policymakers of the benefits of price reforms to shape potential future adjustments and design optimal mitigation policies.

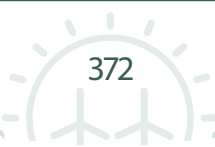
## References

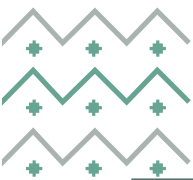
Aryanpur, V., Ghahremani, M., Mamipour, S., Fattahi, M., Gallachóir, B. Ó., Bazilian, M. D., & Glynn, J. (2022). Ex-post analysis of energy subsidy removal through integrated energy systems modelling. *Renewable and Sustainable Energy Reviews*, 158, 112116.

Breton, M., & Mirzapour, H. (2016). Welfare implication of reforming energy consumption subsidies. *Energy policy*, 98, 232-240.

Soummane, S., & Gherzi, F. (2022). Projecting Saudi sectoral electricity demand in 2030 using a computable general equilibrium model. *Energy Strategy Reviews*, 39, 100787.

Soummane, S., Gherzi, F., & Lecocq, F. (2022). Structural transformation options of the Saudi economy under constraint of depressed world oil prices. *The Energy Journal*, 43(3).





## THE ROLE OF THE PETROCHEMICAL SECTOR IN ECONOMIC DIVERSIFICATION IN SAUDI ARABIA

Fakhri Hasanov, King Abdullah Petroleum Studies and Research Center, Phone +966 11 290 3021, E-mail:

[fakhri.hasanov@kapsarc.org](mailto:fakhri.hasanov@kapsarc.org)

Muhammad Javid, King Abdullah Petroleum Studies and Research Center, Phone +966 11 290 3025, E-mail:

[muhammad.javid@kapsarc.org](mailto:muhammad.javid@kapsarc.org)

Heyran Aliyeva, King Abdullah Petroleum Studies and Research Center, Phone +966 11 290 3376, E-mail:

[heyran.aliyeva@kapsarc.org](mailto:heyran.aliyeva@kapsarc.org)

### Overview

This work is a part of the large research study that deals with the representation of the petrochemical sector in KAPSARC Global Energy Macroeconometric Model (KGEMM). It examines the impact of the driving forces on the petrochemical sector and the role of the sector in the economic, energy and environmental developments in Saudi Arabia. There are at least four reasons for a deep study of the petrochemical sector. *First*, the National Industrial Development and Logistics Program (NIDL 2020) and the National Transformation Program (NTP2020) of Saudi Vision 2030 (SV2030) identify the petrochemical sector as a leader in diversifying the Saudi economy. SV2030, the Kingdom's development roadmap, has set aspirational targets for the diversification of the Saudi Arabian economy for the period 2016-2030. For example, Non-oil GDP growth is expected to double compared to 2016. Non-oil exports to increase to 50% of non-oil exports from 16% in 2016. Achieving these and other goals will require rapid growth in the sectors identified in the SV2030 realization programs, and petrochemicals is one of them. *Second*, this sector is the main driver of Saudi non-oil exports. It is worth noting that its share in non-oil exports averaged 62.3% during 1991-2019. The so-called export-led growth concept states that exports can be an engine for long-term economic growth. In this respect, the development of the petrochemical sector and its exports can contribute significantly to the diversification of the non-oil sector's production and exports. *Third*, the government has provided significant support for the development of the sector in the form of investment and energy incentives in the past and plans to continue this support in the coming years in line with SV2030. *Fourth*, there is a favorable environment for the development of the sector when it comes to production inputs such as cheap energy and feedstock. Against this background, this study aims to better understand the developments in the petrochemical sector and their impact on the economy, energy, and environment in Saudi Arabia, and to derive policy insights that can be useful in the decision-making process.

### Data & Methods

With the aim above, the objective of the study is to develop 2-stage modeling framework: *In the first stage*, representations for the petrochemical sector are developed. Precisely, long-run equations and Equilibrium Correction Models are estimated for value added, employment, investment, feedstocks (ethane, LPG, naphtha, methane), and exports (chemicals and plastic-rubber). Annual time series data are used for the estimations. The estimations start in different years, mainly in the 1980s and end in 2019 depending on the data availability. *In the second phase*, the estimated equations and identities are integrated into the KGEMM framework. This allows us to simulate KGEMM up to the year 2035 with different policy and research scenarios. KGEMM is a policy analysis tool for examining the impacts of domestic policy measures and global changes on economic, energy, and environmental relations in Saudi Arabia. KGEMM consists of nine blocks interacting with each other to represent economic, energy and environmental linkages in Saudi Arabia as Figure 1 illustrates.

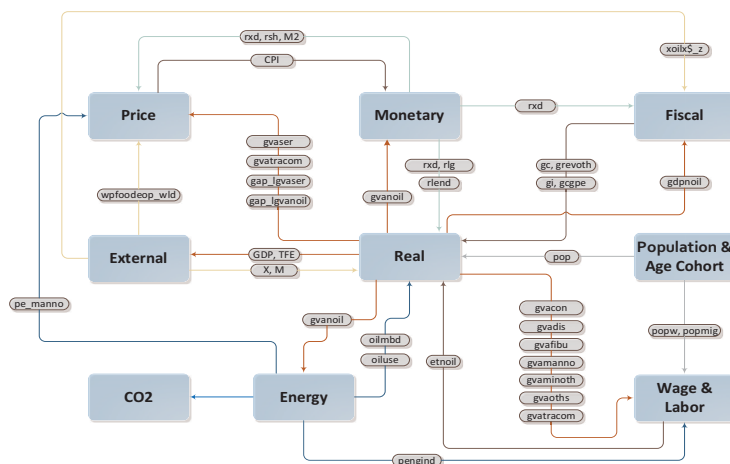
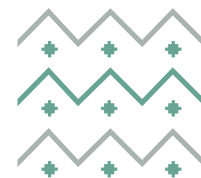


Figure 1. KGEMM structure





Information such as KGEMM theoretical foundation, econometric methods, variables, and database can be found in Hasanov et al. (2020).

## Results

In this conference presentation, due to space constraints, we focus only on petrochemical sector exports and their impact on the diversification of the non-oil export and value-added. Therefore, we report here only the long-run equations estimated for two export products, i.e., chemicals and plastic-rubber. We specify Saudi Arabia's exports as a function of trading partner income, the real effective exchange rate (REER), a measure of international competitiveness, and domestic production capacity, all in the natural logarithm (log) transformation following the export literature. The REER is defined as the nominal effective exchange rate (an increase in the REER implies an appreciation of the Riyal) times the ratio of domestic prices to foreign prices (which are specific to chemicals and plastic-rubber). Table 1 documents the estimation results.

**Table 1.** Long-run estimation results for exports of chemicals and plastic-rubber

	Log(chemicals export)	Log(plastic-rubber export)
Log(foreign income)	0.30**	1.05**
Log(domestic production capacity)	0.44*	0.88**
Log(real effective exchange rate)	-0.14**	-0.13**

Note: Deterministic terms are dropped to save space; As a proxy for domestic capacity, non-oil value added and petrochemical value added are used in the chemical export and plastic-rubber export equations; \*\*, \* are the statistical significance at the 10% and 5% levels, respectively. All the dependent and explanatory variables are integrated order of one process according to the unit root test results and long-run relationship in the equations are confirmed by the cointegration tests, such as Engle-Granger.

Plastic-rubber exports have a one-to-one relationship with trading partner's income and domestic production capacity, while chemical exports show relatively small response to these determinants. Similarly, both export products show a statistically significant response to the REER, albeit with small magnitudes.

Next, we simulated KGEMM in two scenarios: Basecase scenario, in which we made no changes-the Saudi economy moves forward as it is in 2022. Scenario 1, in which we increased foreign prices for exports of chemical and plastic-rubber by 10% for the period 2022-2035. Table 2 contains the simulation results.

**Table 2.** Deviation of scenario 1 from the basecase, % change.

Year	Exports		Non-oil		Share of	
	Chemicals	Plastic-rubber	Export	Value-added	Non-oil export in total	Non-oil value-added in GDP
2022	1.49	1.37	0.88	0.14	0.74	0.06
2025	1.53	1.44	0.89	0.22	0.70	0.09
2030	1.58	1.54	1.04	0.33	0.79	0.13
2035	1.67	1.70	1.27	0.51	0.93	0.20
<b>Average</b>	<b>1.57</b>	<b>1.51</b>	<b>1.02</b>	<b>0.30</b>	<b>0.79</b>	<b>0.12</b>

The simulation results show that, on average, a 10% increase in foreign prices leads to an increase in exports of chemicals and plastic-rubber in Scenario 1 by about 2% compared to the basecase. This also leads to an increase in total non-oil exports and value added by 1% and 0.3%, respectively. Consequently, the shares of non-oil exports in total exports and non-oil value added in GDP (as diversification indicators) increase by 1% and 0.1%, respectively.

## Conclusions

The main conclusion of the analysis is that petrochemical exports can make a positive contribution to the development and diversification of the non-oil sector. Policymakers may wish to take measures to increase exports of chemicals and plastic-rubber. In this context, they should consider that plastic-rubber exports are more responsive to foreign income and domestic production capacity than chemical exports. The real exchange rate also plays an important role in the behavior of both products' exports. Since the fixed exchange rate of the Riyal to the U.S. dollar is followed in Saudi Arabia, policymakers should pay attention to the relationship between domestic and foreign prices. In this regard, measures to maintain the stability of domestic prices for chemicals and plastic-rubber are important for growth and diversification of non-oil exports and value-added.

## References

Hasanov, Fakhri, Frederick L. Joutz, Jeyhun I. Mikayilov, and Muhammad Javid. KGEMM: A Macroeconometric Model for Saudi Arabia. KAPSARC Discussion Paper. No. ks-2020-dp04. 2020.





## Financial and Energetic Investigation of Saudi District cooling system

[Dr. Mohammad Alobaid, Department of Mechanical Engineering, Majmaah University, Al Majma'ah, 11952 Riyadh, Saudi Arabia, 0503284080, m.alobaid@mu.edu.sa]

### Overview

Cost optimal analysis technique was employed to assist the performance of building in order to minimize the energy consumption [1]. District energy (DC) is a pipeline infrastructure covering urban areas that connects thermal sources to thermal sinks. " as shown in figure1 [2]. "The results indicate that DC is responsible for a minor part of the useful energy demand of Europe for cooling with around 3 TWh/y." [3]. Compare to a conventional air-conditioning systems, applying district cooling technology (DC) can significantly reduce the energy consumption for cooling purposes. Basically DC is a combined cold resource system designed for distributing chilled water via a fluid based pipe network to meet buildings cooling demand of the end-users [2].

The plan of Ministry of Housing in the Kingdom of Saudi Arabia included 133 residential projects which will provide 154,676 accommodation units. employing DC systems in this project is expected to provide a significant impact on reducing energy consumption and gas emissions. Based on cooling load profile, the overall capacity was determined. A case study for a new campus in Saudi Arabia is studied to find out the energy consumption based on the local rate for electricity at 2022. Load of air-conditioning for a typical house is considered to investigate energy saving based on the season throughout the year [4]. This study included the cost estimation of the proposed system compared to a unitary system. The impact on the energy saving and the environment was highlighted.

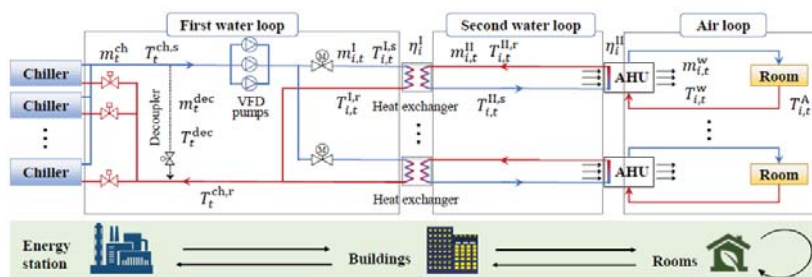
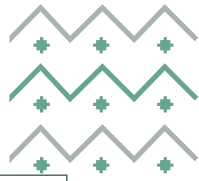


Figure 1 Schematic diagram of a district cooling system [5].

Globally needed for energy are supplied 75% from convention resources such as fossil fuel [6]. 10% of worldwide CO<sub>2</sub> emissions are brought on by refrigeration and air conditioning[7]. There are generally two types of air-conditioning systems unitary and centralized systems which usually have better energy performances. Employing District cooling systems (DC) technology is expected to reduce annual energy consumption by 15% and also reduce carbon emissions by 15.0% [8]. Some of advantages of DC systems combines the chillers required in each building into a central plant, reduction in the cost of equipment in the building, more space on building roofs and help to reduce energy consumption, gas emission such as carbon dioxide. DC has been a subject of research since the late of the nineteenth century when the refrigerants was the main fluid in the piping system. The second generation of the DC was based on the water as a distribution fluid that supplied child water to the demanding zones. The third generation was based on mix of cooling sources such as adding natural cooling rather than depending on just a compression chiller. The fourth generation of DC employed renewable energy , smart control system and also district heating system [2].

Win-win situation between the end-user and the investor of district cooling systems. 37 commercial and residential building were designed to be supplied by DCS. Several groups of chilled water systems were supplied 3400 refrigeration tons. Ice storage system reduced approximately 4% of the operation cost. It was recommended that to employed a power generating system which saved approximately 30% compared to conventional DCS [9]. DC provide an opportunity to utilize local resources to produce cooling. This included utilizing renewable energy, waste energy or free cooling. The efficiency of DC systems exceeded times higher than a conventional air-conditioning. More space instead of equipment on the buildings roofs as well as less noise. Analyzing the demand for cooling and potential end-



user is the first step for the feasibility study of DC [10] [11]. A case study in Riyadh investigated the performance of Solar district cooling system to supply a compound of several villa [12]. Figure 2 represents a cooling load in a typical villa in Riyadh throughout the year which required a cooling power up to 48 KW to meet the cooling demand in the peak time in the summer.

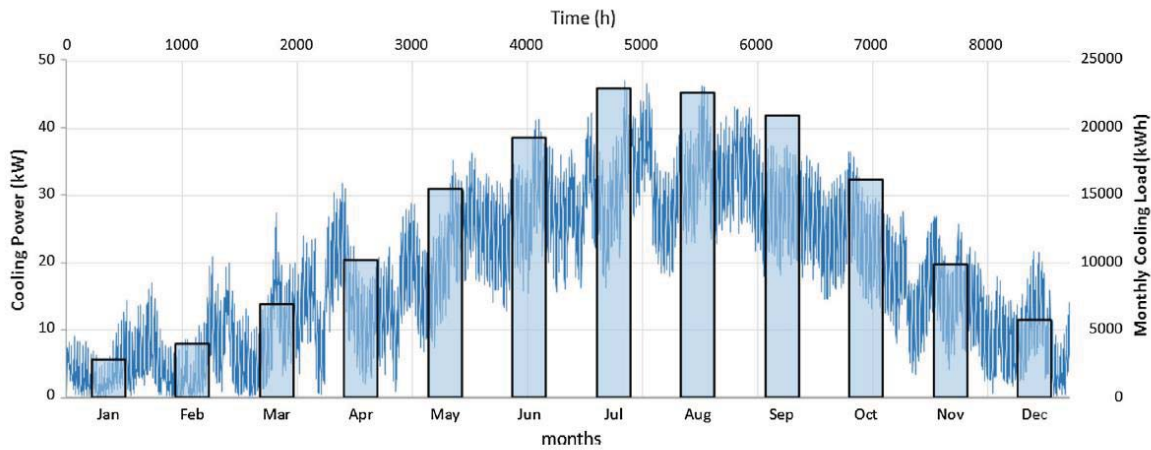


Figure 1 Cooling load in a typical villa in Riyadh throughout the year [12].

New campus on Saudi Arabia has been taken as a case study. The focus was on air-conditioning load on building which is affected by the building insulation. A modified bin method was employed to optimize the energy efficiency ratio (EER) [13]. Approximately 213 USD billion required to be invested in desalination and electricity sector to meet the Kingdom demand [14]. The DC network infrastructure, which frequently constitutes the largest initial investment in a DC system (i.e., typically 50–75% of the total cost), requires careful design and optimal operation [15].

## Methods

The plan of Ministry of Housing in the Kingdom of Saudi Arabia included 133 residential projects which will provide 154,676 accommodation units. A case study in Riyadh from the Ma'ali Annan project is taken to analyze the cooling load and electricity consumption. The project includes 440 housing units available in one type of housing unit (villa). The project is located on an area with approximately 105,000 square meters. Energy consumption was calculated and CO<sub>2</sub> emissions was estimated based on [16] for different alternative cooling systems. To meet the cooling load which is approximately 22 RT for a Villa in this project, 13 conventional air conditioner units suggested to be installed as a reference system.

## Results

For a typical house in the case study, a reduction in energy consumption, when replaced unitary units with EER of 7.5 to units with EER of 12, was 1497.6 KWh/Month. This represents a saving of approximately 270 SR/Month of the electricity bill. A reduction of CO<sub>2</sub> emissions was 711 kg/Month for each house.

The reduction on the energy consumed by the residential project for the cooling system when moved to DC was in the range of 59.304 MWh/month to 0.415 GWh/Month which lead to reduce CO<sub>2</sub> emissions to the range up to 0.2 kt/month

## Conclusions

Economical and environmental updated results of residential energy sector were reported in this study. Utilising DC to meet the demand for air-conditioning systems in atypical project in Saudi Arabia was evaluated economically and environmentally. A case study was investigated to analyse energy consumption based on the local rate electricity. Employing DC technology is expected to reduce monthly energy consumption up to 0.415 GWh/Month and also reduce carbon emissions by 0.2 kt/month. Environmental index which included CO<sub>2</sub> emissions, net savings with the proposed system and Levelized COE (nominal) were also investigated.

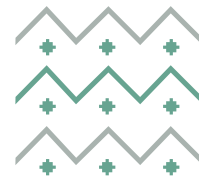
## References

- [1] R. Bruno, P. Bevilacqua, C. Carpino, and N. Arcuri, "The cost-optimal analysis of a multistory building in the Mediterranean area: Financial and macroeconomic projections," *Energies*, vol. 13, no. 5, 2020, doi: 10.3390/en13051243.



- [2] P. A. Østergaard *et al.*, "The four generations of district cooling - A categorization of the development in district cooling from origin to future prospect," *Energy*, vol. 253, p. 124098, 2022, doi: 10.1016/j.energy.2022.124098.
- [3] S. Pezzutto *et al.*, "Recent Advances in District Cooling Diffusion in the EU27 + UK : An Assessment of the Market," 2022.
- [4] J. Lim, M. S. Yoon, T. Al-Qahtani, and Y. Nam, "Feasibility study on variable-speed air conditioner under hot climate based on real-scale experiment and energy simulation," *Energies*, vol. 12, no. 8, 2019, doi: 10.3390/en12081489.
- [5] P. Yu, H. Hui, H. Zhang, G. Chen, and Y. Song, "District Cooling System Control for Providing Operating Reserve based on Safe Deep Reinforcement Learning," pp. 1–14, 2021, [Online]. Available: <http://arxiv.org/abs/2112.10949>.
- [6] A. S. Kalagasidis and Y. Zhang, "Assessment of district heating and cooling systems transition with respect to future changes in demand profiles and renewable energy supplies," vol. 268, no. July, 2022, doi: 10.1016/j.enconman.2022.116038.
- [7] P. Options, "The Future of Cooling in Saudi Arabia : Technology , Market and Policy Options," no. August, 2020, doi: 10.30573/KS--2020-WB08.
- [8] K. Hinkelman *et al.*, "Modelica-based modeling and simulation of district cooling systems : A case study Authors University of California Modelica-Based Modeling and Simulation of District Cooling Systems : A Case Study," 2022, doi: 10.1016/j.apenergy.2022.118654.
- [9] W. Gang, S. Wang, F. Xiao, and D. Gao, "Performance Assessment of District Cooling System Coupled with Different Energy Technologies in Subtropical Area," *Energy Procedia*, vol. 75, pp. 1235–1241, 2015, doi: 10.1016/j.egypro.2015.07.166.
- [10] L. Pampuri, N. Cereghetti, D. Strepparava, and P. Caputo, "Analysis of the electricity consumptions: A first step to develop a district cooling system," *Sustain. Cities Soc.*, vol. 23, pp. 23–36, 2016, doi: 10.1016/j.scs.2016.02.015.
- [11] Z. Shi, J. A. Fonseca, and A. Schlueter, "Floor area density and land uses for efficient district cooling systems in high-density cities," *Sustain. Cities Soc.*, vol. 65, no. November 2020, p. 102601, 2021, doi: 10.1016/j.scs.2020.102601.
- [12] G. Franchini, G. Brumana, and A. Perdichizzi, "Performance prediction of a solar district cooling system in Riyadh, Saudi Arabia – A case study," *Energy Convers. Manag.*, vol. 166, no. May, pp. 372–384, 2018, doi: 10.1016/j.enconman.2018.04.048.
- [13] M. Elhelw, "Analysis of energy management for heating, ventilating and air-conditioning systems," *Alexandria Eng. J.*, vol. 55, no. 2, pp. 811–818, 2016, doi: 10.1016/j.aej.2016.01.034.
- [14] M. Krarti and M. Aldubyan, "Mitigation analysis of water consumption for power generation and air conditioning of residential buildings : Case study of Saudi Arabia," *Appl. Energy*, vol. 290, no. December 2020, p. 116767, 2021, doi: 10.1016/j.apenergy.2021.116767.
- [15] V. Evely and D. S. Ayou, "Sustainable district cooling systems: Status, challenges, and future opportunities, with emphasis on cooling-dominated regions," *Energies*, vol. 12, no. 2, 2019, doi: 10.3390/en12020235.
- [16] <https://www.iea.org/reports/global-energy-co2-status-report-2019/emissions> ( IEA (2019), *Global Energy & CO2 Status Report 2019*, IEA, Paris <https://www.iea.org/reports/global-energy-co2-status-report-2019>, License: CC BY 4.0)





## Synthesis and Fabrication of MoS<sub>2</sub> QDS Thin Films for Novel Optoelectronic Devices with Cost-Efficient Technique

Maymunah A. Alwehaibi, Princess Nourah bint Abdulrahman University, +966580560676, 439000991@pnu.edu.sa  
 Yasmeen A. Khoja, Princess Nourah bint Abdulrahman University, +966500027898, 439000892@pnu.edu.sa  
 Reem S. Alghamdi, Princess Nourah bint Abdulrahman University, +96657459053, 439004167@pnu.edu.sa  
 Fahdah A. Alsuhaiyani, Princess Nourah bint Abdulrahman University, +966535388926, 439004478@pnu.edu.sa  
 Norah M. Alwadi, Princess Nourah bint Abdulrahman University, +966566616128, nmalwadai@pnu.edu.sa  
 Manar S. Alshatwi, Princess Nourah bint Abdulrahman University, +9665381226268, msalshatwi@pnu.edu.sa

### Overview

The impact of the COVID-19 pandemic on the semiconductors manufacturing industry leads to a necessity for typical research work. For this reason, our work chose molybdenum disulfide (MoS<sub>2</sub>), an organic semiconductor with high neutral abundance, low cost, high carrier mobility, unique optical properties, fixable bandgap, and very low toxicity that make MoS<sub>2</sub> a very safe and sustainable material. This work successfully synthesizes MoS<sub>2</sub> quantum dots (MoS<sub>2</sub> QDs) by liquid exfoliation to fabricate MoS<sub>2</sub> QDs thin film by spray technique. The extract MoS<sub>2</sub> QDs were characterized using scanning electron microscopy (SEM), Fluorescence emission spectra (FES), UV-VIS spectroscopy, and Energy-dispersive X-Ray (EDX). The SEM images have shown the MoS<sub>2</sub> QDs with sizes ranging from (~ 4-11 nm), a spherical shape with a homogenous distribution. With strong UV absorption and bandgap=4.49eV corresponding to UV-VIIS spectroscopy result. Moreover, the MoS<sub>2</sub> QDs show a fluorescence spectrum under excitation of 340 nm. The MoS<sub>2</sub> QDs are spray-coated onto a substrate to fabricate thin film. The Photoluminescence (PL) results show an expansion in emission with high sensitivity covering the whole visible light region (380-700 nm), which makes MoS<sub>2</sub> QDs thin films promising for optoelectronic devices such as solar cells and photodetectors.

### Methods

#### 1. Synthesis of n-MoS<sub>2</sub> QDs

We successfully synthesized n-MoS<sub>2</sub> QDs through the liquid phase exfoliation method, as shown in Fig.1

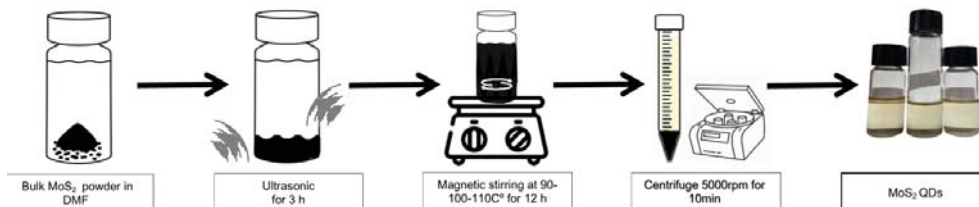


Fig. 1 Process of synthesizing n-MoS<sub>2</sub> QDs

#### 2. Thin film deposition

The device fabrication was achieved, and the Fabrication process illustrate in details in Fig.2

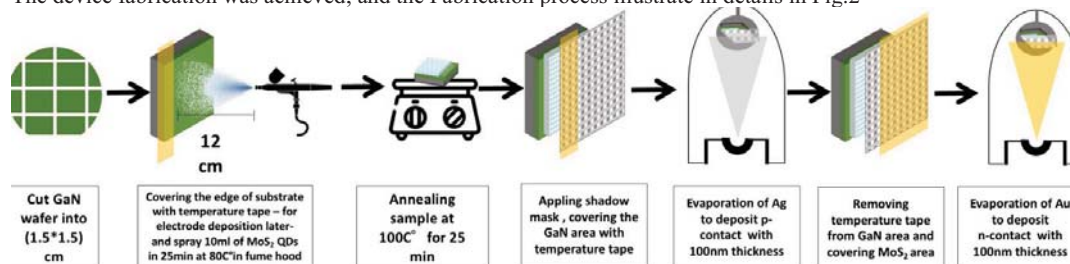


Figure.2 Process of p-GaN/N-MoS<sub>2</sub> device fabrication





## Results

- The SEM images have shown the MoS<sub>2</sub> QDs with sizes ranging from (~ 4-11 nm), a spherical shape with a homogenous distribution shown in fig.3

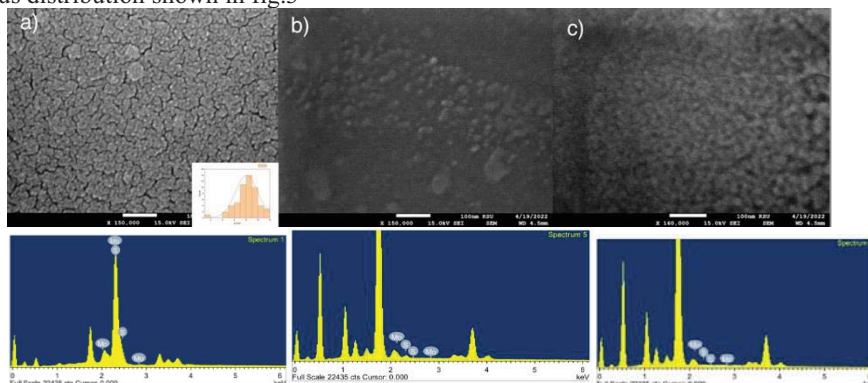


Figure.3 SEM image and EDX result of prepaed sample at (a) 90 °C (b) 100 °C (C) 110 °C

- Strong UV absorption and bandgap 4.49eV corresponding to UV- VIS spectroscopy result as shown in Fig. 4a. Moreover, the MoS<sub>2</sub> QDs show a fluorescence spectrum under excitation of 340 nm as shown in Fig. 4b and under UV light in Fig. 4c. while the PL peak of n-MoS<sub>2</sub> QDs laying in the range of nm the prepared sample was excited under different wavelengths  $\lambda_{excitation}$  from 270nm to 450nm where maximum peak found at 408 nm corresponding to  $\lambda_{excitation} = 350$ nm as shown in Fig. 4d.

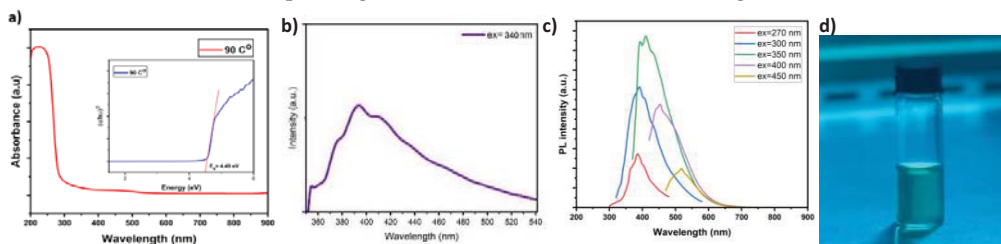


Figure.4 (a) UV-Vis absorption and Tauc plot of n-MoS<sub>2</sub> QDs prepared at 90 °C (b) Fluorescence spectra of n- MoS<sub>2</sub> QDs under  $\lambda_{excitation} = 340$ nm (C) Photoluminescence spectra of n- MoS<sub>2</sub> QDs under different  $\lambda_{excitation}$  °C (d) n-MoS<sub>2</sub> QDs under UV lamps

- The result shows a promising thin film for optoelectronic devices. For this reason, the p-GaN/n-MoS<sub>2</sub> QDs photodetector was fabricated and characterized. The PL results in Fig. 5a show expansion in the emission spectrum to cover the visible region, while the I-V characteristic in Fig. 5b shows photodiode behavior.

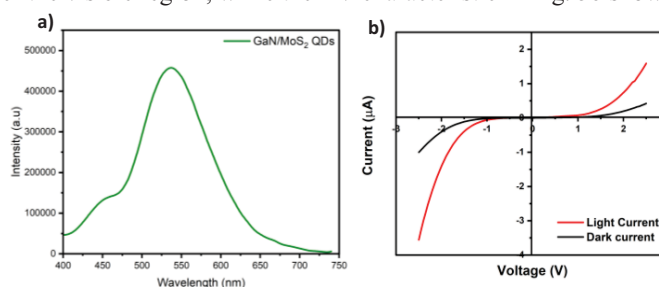
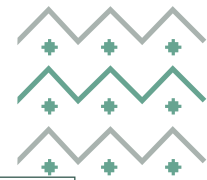


Figure.5 (a) p-GaN N-MoS<sub>2</sub> QDs with the maximum intensity at the peak of 537nm (b) Current as a function of voltage for p-GaN/N-MoS<sub>2</sub> heterojunction photodetector

## Conclusions

This work successfully synthesis n-MoS<sub>2</sub> QDs from bulk MoS<sub>2</sub> powder by liquid phase exfoliation in DMF. The samples were prepared at various temperatures where 90C exhibited the best result with strong quantum confinement, Eg4.49 eV, expanding absorbance, and fluorescence behavior at  $\lambda_{excitation} = 340$ nm. p-GaN/n-MoS<sub>2</sub> QDs photodetector was fabricated and characterized at [-2.5-2.5]; the device showed high performance with a responsivity of 7.069 mA/W and detectivity of  $1.24 \times 10^{10}$  Jones at visible light region.





**INVESTMENT IN FOSSIL FUELS AND ENVIRONMENTAL DEGRADATION IN NIGERIA: POLICY OPTIONS TO MITIGATE THE POTENTIAL TRADE-OFFS**

Ladi R. Bala-Keffi, Central Bank of Nigeria, +2347033149040, [ladisplace@yahoo.co.uk](mailto:ladisplace@yahoo.co.uk)

**Overview**

The Sustainable Development Goals (SDGs) emphasize the need for a careful balance between social, economic, and environmental sustainability. This is because environmental quality affects economic development and vice versa, thus the importance of this global goal. Most governments and policymakers are increasingly interested in understanding the implications of environmental issues for the world economy, especially with respect to clean energy. In reality, the simultaneous achievement of these goals are unlikely due to possible conflicts between them. This trade-off may arise due to the excessive use of natural resources that cause environmental pollution and distort the growth process. Countries like Nigeria, with high dependence on natural resources, face challenges of environmental pollution, which has consequences for macroeconomic policies in Nigeria. Energy continues to be a crucial component of the production process (Ozcan & Ozturk, 2019; Sarkodie & Ozturk, 2020), and investments in the sector have continued to grow. Similarly, CO2 emissions, ocean acidification, deforestation, water levels, and air pollution have also increased depicting an expansion in human economic activity (Graff-Zivin, 2018). Carbon dioxide emission, which comes from major fossil fuels (coal, gas, and oil) are the main greenhouse gas that causes global warming (Xu, Liu & Wu, 2021; Gani, 2021). Empirical evidence from the literature emphasized that several factors such as modernization, urbanization, energy consumption, renewable and hydro energy, and natural gas are associated with an increase in greenhouse gas emissions (GHE) (Tobelmann & Wendler, 2020; Li et al., 2019; Eberle & Heath 2020; Xu, Liu & Wu, 2021). Further evidence reveals that an increase in energy consumption is associated with a rise in carbon dioxide emissions in sub-Saharan Africa (Shahbaz, Solarin, Sbia & Bibi, 2015; Lin & Agyeman, 2020; Xu, Liu & Wu, 2021). Africa still lags in total CO2 emissions, which stood at 4 percent of global fossil fuel emissions in 2017 (Ayompe, Davis & Egoh, 2021). As investments in the energy sector increase, it is expected that CO2 emissions in the continent will rise, given the projection of rapid growth of population and per capita GDP in Africa (Ayompe et al, 2021). This is even more worrisome as a rise in population leads to the rising energy demand that translates into massive investments in oil, coal, gas exploration, and extraction. In Nigeria, there is heavy investment in the oil and gas sector aimed at increasing production levels (Ahmad & Du, 2017; Koengkan, 2018; Hanif, 2018). This is because of the dependence of households, businesses, and governments on traditional energy for individual and productive purposes. This makes the country vulnerable to climate change (AfDB, 2022; CDP; 2020) and underscores the need for policy options to diversify the Nigerian economy away from oil. Given Nigeria's overreliance on fossil fuel to drive economic growth, this study will highlight the implications of further investment in the oil and gas sector and the consequences for environmental degradation in Nigeria. Against this backdrop, this paper seeks to evaluate the impact of investment in fossil fuels on environmental degradation in Nigeria and the implications for sustainable development.

**Methods**

To investigate the implication of investment in fossil fuels on environmental degradation in Nigeria, the study will utilize secondary data from relevant institutions. Two proxies will be used for environmental degradation (CO2 emissions and environmental sustainability index). Both descriptive and econometric methods of analysis will be employed to give empirical content to the stated objectives. Regime switching models and nonlinear models will be used in analyzing the stated objectives. The study will hinge on the Environmental Kuznet's Curve which believes there is evidence of a nonlinear relationship between the growth of an economy and the level of environmental degradation. Thus, the optimal level of investment in fossil fuels beyond which growth in the sector affects the environment is essential for policy formulation.

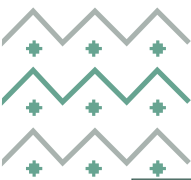
**Expected Results**

It is expected that investment in fossil fuels will have a dual effect on the Nigerian economy. It is likely to affect economic growth positively in the short term, but negatively in the long-run. On the flip side, it may not affect environmental sustainability in the short-run, but the impact may be severe in the long run. The optimal trade-off point between them will be estimated to aid policy analysis.

Classified as Confidential

Energy and the Economy





## Conclusion

It is expected that the indicators of environmental sustainability will respond negatively to investments in fossil fuel. This is in line with the postulation of the theoretical framework and empirical literature of the study.

## References

- African Development Bank (2022). African Economic Output, 2022. Chapter 2: Climate Resilience and a just Energy Transition in Africa
- Ahmad, N., & Du, L. (2017). Effects of energy production and CO<sub>2</sub> emissions on economic growth in Iran: ARDL approach. *Energy*, 123, 521-537.
- Ayompe, L.M., Davis, S.J. and Egoh, B.N. (2021). Trends and drivers of African fossil fuel CO<sub>2</sub> emissions 1990–2017. *Environ. Res. Lett.* 15 124039
- CDP (2020). Africa report benchmarking progress towards climate safe cities, states, and regions. March 2020. Available only at [https://cdn.cdp.net/cdp-production/cms/reports/documents/000/005/023/original/CDP\\_Africa\\_Report\\_2020.pdf?1583855467](https://cdn.cdp.net/cdp-production/cms/reports/documents/000/005/023/original/CDP_Africa_Report_2020.pdf?1583855467)
- Gani, A. (2021). Fossil fuel energy and environmental performance in an extended STIRPAT model. *Journal of Cleaner Production* 297 (2021) 126526
- Graff-Zivin, J. (2018). Environmental policy-making: Theory & practice. Rockefeller Foundation, Economic Council on Planetary Health
- Hanif, I. (2018). Energy consumption habits and human health nexus in Sub-Saharan Africa. *Environmental Science and Pollution Research*, 1-12
- Hansen, P. (2020). Nigeria Has Experienced a 271% Increase in Greenhouse Gas Emissions Since 1990. Available one at <https://www.climatecard.org/2020/12/nigeria-has-experienced-a-271-increase-in-greenhouse-gas-emissions-since-1990/>
- Intergovernmental Panel on Climate Change, 2018. Global warming of 1.5 degrees C. <https://www.ipcc.ch/sr15>
- International Energy Agency, 2017. World energy outlook 2017. [www.iea.org](http://www.iea.org)
- International Energy Agency, 2019a. World energy outlook 2019. [www.iea.org](http://www.iea.org)
- Koengkan, M. (2018). The decline of environmental degradation by renewable energy consumption in the MERCOSUR countries: an approach with ARDL modeling. *Environment Systems and Decisions*, 1-11.
- Kuznets, S. (1955). Economic growth and income inequality. *The American economic review*, 45(1), 1-28
- Li S, Chunshan Z, Wang S (2019) Does modernization affect carbon dioxide emissions? A panel data analysis. *Sci Total Environ* 663:426–435
- Li, Mo; Wiedmann, T. and Hadjikakou, M. (2019). Enabling full supply chain corporate responsibility: scope 3 emissions targets for ambitious climate change mitigation. *Environmental Science & Technology*, (), *acs.est.9b05245*–. doi:10.1021/acs.est.9b05245
- Ozturk, I., Al-Mulali, U., 2019. Investigating the trans-boundary of air pollution between the BRICS and its neighboring countries: an empirical analysis. In: Shahbaz, M., Balsalobre, D. (Eds.), *Energy and Environmental Strategies in the Era of Globalization. Green Energy and Technology*. Springer, Cham. [https://doi.org/10.1007/978-3-030-06001-5\\_2](https://doi.org/10.1007/978-3-030-06001-5_2).
- Sarkodie, S.A., Ozturk, I., 2020. Investigating the environmental Kuznets curve hypothesis in Kenya: a multivariate analysis. *Renew. Sustain. Energy Rev.* 111 <https://doi.org/10.1016/j.rser.2019.109481>
- Shahbaz, M., Solarin, S.A., Sbia, R. and Bibi, S. (2015). Does energy intensity contribute to CO<sub>2</sub> emissions? A trivariate analysis in selected African countries. *Ecol. Indic.*, 50, 215–224
- Tobelmann D, Wendler T (2020) The impact of environmental innovation on carbon dioxide emissions. *J Clean Prod* 244:118787
- u, Z., Liu, L. & Wu, L. Forecasting the carbon dioxide emissions in 53 countries and regions using a non-equipart grey model. *Environ Sci Pollut Res* 28, 15659–15672 (2021). <https://doi.org/10.1007/s11356-020-11638-7>
- Xu, Z., Liu, L. and Wu, L. (2021). Forecasting the carbon dioxide emissions in 53 countries and regions using a non-equipart grey model. *Environmental Science and Pollution Research*, 28, 15659–15672





[**LINEAR AND FACTOR OIL PRICE FORECASTS**]

[Dr. Abdullah Al Shammre, King Faisal University, Saudi Arabia, 096655938238, [ashammre@kfu.edu.sa](mailto:ashammre@kfu.edu.sa)]  
 [Dr. Benaissa Chidmi, Texas Tech University, Lubbock, United States, 018606340512, [benaissachidmi@gmail.com](mailto:benaissachidmi@gmail.com)]

**Overview**

This study deals with presenting and estimating different oil price forecasting models. We consider some traditional time series models, such as random walk, autoregressive (AR), moving average (MA), and autoregressive integrated moving average (ARIMA) to forecast oil prices. The previous models are augmented by including factors or components resulting from the data reduction process and summarizing the information contained in 128 variables of the Federal Reserve Economic Data. To this end, we employ two data reduction techniques: principal component analysis and partial least squares analysis. In the former, we extract the most critical components without using the oil price variable. In partial least squares, we extract the components factors using the 128 economic indicators and the oil price.

**Methods**

We present the different models that describe the process of oil price forecasting. First, I describe the linear time series models, including the random walk, autoregressive (AR), moving average (MA), and autoregressive integrated moving average (ARIMA) to forecast oil prices. The study considers using principal component analysis (PCA) and partial least squares (PLS) to extract factors to be used in addition to the ARIMA process (ARIMAX).

**Results**

The results in table 4.9 indicate that the coefficient for MA(1) and factor 5 and 6 labeled as employment and exchange rates are statistically significant at 1% level, while MA(2) and factor 7, labeled as inflation factor are statistically significant at 5% level of significance. Employment and inflation factors have a positive and statistically significant impact on oil price. However, the exchange rates factor has a negative and statistically significant impact on oil price. Factors 1, 4, 8, and 10 have a negative and statistically insignificant impact on oil price. Compare to RW, AR(2), MA(1), ARIMA(0,1,1), partial least squares provide the lowest volatility value of 1.78, the lowest AIC 1884.14, and the highest log likelihood of -929.07 among all previous models that we estimated except PCA, where PCA provide the same volatility value of 1.7 and the highest log likelihood of -928.5. Regarding to the magnitude of coefficients, the MA(1) has greater impact on oil price compared to all PLS factors.

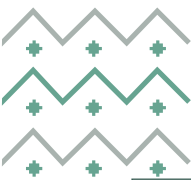
Our sample period is from March 1959 to November 2019, while the out-of-sample assessment period starts from December 2004. table 4.12 compares the forecasting performance for all the forecasting models, the lower error indicates a more accurate prediction. Forecasts based on Arima with PLS and PCA factors can be considered more accurate than the forecast based on the benchmark model as well as plain Arima. However, PLS model with 10 factors provide significantly better predictions and outperforming the PCA regression with 11 factors. Therefore, PLS can select the effective predictors from a large set of indicators and demonstrate strong out-of-sample predictive power relative to PCA.

**Table 4.11.** Forecast performance

Metrics	RW	AR	MA	ARIMA	ARIMA(PCA)	ARIMA(PLS)
RMSE	1.00	1.50	3.49	0.97	1.38	1.35
MAPE	1.00	1.39	3.53	0.98	3405.27	1932.02
MAE	1.00	1.29	3.39	1.00	-	-

Note: This table reports the ratio of the out-of-sample RMSE of the random walk (RW) model various forecasting models for the oil price, the autoregressive (AR) model, the moving average (MA), the autoregressive integrated moving average (ARIMA), the principal components analysis and partial least squares (PLS). Values below one favor the random walk (RW) model.





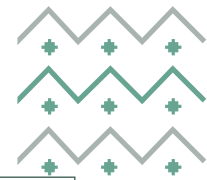
## Conclusions

In this study, we construct different oil prices forecasting models and estimate them with 128 monthly indicators that tell a complex macroeconomic story of the US economy from 1959 to 2020. This study deals with presenting and estimating different oil price forecasting models. The study divides the forecasting models into linear and factor models.

## References

- Abdel-Aal, R. E., & Al-Garni, A. Z. (1997). Forecasting monthly electric energy consumption in eastern Saudi Arabia using univariate time-series analysis. *Energy*, 22(11), 1059-1069.
- Agnolucci, P. (2009). Volatility in crude oil futures: a comparison of the predictive ability of GARCH and implied volatility models. *Energy Economics*, 31(2), 316-321.
- Alexander, S. S. (1964). Price Movements in Speculative Markets—Trends or Random Walks, Number 2. *IMR; Industrial Management Review* (pre-1986), 5(2), 25.
- Aloui, C., & Mabrouk, S. (2010). Value-at-risk estimations of energy commodities via long-memory, asymmetry and fat-tailed GARCH models. *Energy Policy*, 38(5), 2326–2339.
- Alquist, R., & Kilian, L. (2010). What do we learn from the price of crude oil futures?. *Journal of Applied econometrics*, 25(4), 539–573.
- Álvarez-Díaz, M. (2019). Is it possible to accurately forecast the evolution of Brent crude oil prices? An answer based on parametric and nonparametric forecasting methods. *Empirical Economics*, 1-21.
- Bacon, R. (1991). Modelling the price of oil. *Oxford review of economic policy*, 7(2), 17-34.
- Bai, J. (2003). Inferential theory for factor models of large dimensions. *Econometrica*, 71(1), 135-171.
- Bai, J., Ng, S. (2002). Determining the number of factors in approximate factor models. *Econometrica*, 70(1), 191-221.
- Binder, K. E., Pourahmadi, M., Mjelde, J. W. (2020). The role of temporal dependence in factor selection and forecasting oil prices. *Empirical Economics*, 58(3), 1185-1223.
- Blanchard, M., & Desrochers, G. (1984). Generation of autocorrelated wind speeds for wind energy conversion system studies. *Solar Energy*, 33(6), 571-579.
- Boivin, J., & Ng, S. (2006). Are more data always better for factor analysis?. *Journal of Econometrics*, 132(1), 169-194.
- Box, G. E. P., & Jenkins, G. M., & Reinsel, G. C. (1994). *Time Series analysis forecasting and control* (3rd ed.). Englewood Cliffs, N. J. Prentice Hall Press.
- Box, G. E., & Jenkins, G. M. (1976). *Time Series of Analysis, Forecasting and Control*, San Fransisco, Helden-Day. California. USA.
- Brockwell, P.J., Davis, R.A.: *Introduction to Time Series and Forecasting*, 2<sup>nd</sup> edn, p. 449. Springer, New York (2002).
- Brown, B. G., Katz, R. W., & Murphy, A. H. (1984). Time series models to simulate and forecast wind speed and wind power. *Journal of climate and applied meteorology*, 23(8), 1184-1195.
- Brunetti, C., & Gilbert, C. L. (2000). Bivariate FIGARCH and fractional cointegration. *Journal of Empirical Finance*, 7(5), 509-530.
- Campbell, B., & Dufour, J. M. (1997). Exact nonparametric tests of orthogonality and random walk in the presence of a drift parameter. *International Economic Review*, 151–173. Chamberlain, G., & Rothschild, M. (1982). Arbitrage, factor structure, and mean-variance analysis on large asset markets.





## *The Relationship Between Financial Development And Renewable Energy Consumption On CO2 Emissions And Economic Growth In The G20 Countries*

Prepared by: Fatimah Saad Al Kaboor , 0566221955 , ward-11102@hotmail.com

Under Supervision of Dr. Abdullah Sultan Al-Shammri, 0555938238, ashammre@kfu.edu.sa

### Overview

Energy is a significant source of economic and social development that constitutes the crucial keys and enhances all aspects of the economy for any country. Undoubtedly, energy availability and consumption in the necessary quantities are necessary to achieve the desired economic growth rates. Moreover, it is impossible to achieve economic development and growth in light of environmental deterioration and the depletion of natural resources (Karimi, et al., 2021).

Nowadays, environmental degradation has become a significant challenge in all countries of the world, whether developed or developing, and ecological problems have become no less important than other economic problems. The global concern about environmental sustainability has begun to increase, especially after the increase in greenhouse gases in the layers of the atmosphere, which constitute an obstacle to the exit of sunlight reflected from the earth. Many indicators increase CO2 emissions, and fossil fuels are one of the most critical indicators heavily augmented by economic growth. There are many research debates about the role of economic factors on health issues, environmental degradation, and other factors that can affect the economic growth of emerging countries (Hanif, 2018).

It is noteworthy that energy, with its renewable and non-renewable sources, is an essential pillar for achieving all dimensions of sustainable development. Renewable energy is defined as the energy produced through natural resources, which are continuously renewed and inexhaustible. The most important aspect of this energy is that it is a clean and environmentally friendly energy. It does not usually produce harmful residues such as carbon dioxide or other toxic gases. The main motive for using renewable energies is the environmental motive, to reduce carbon dioxide emissions (Park & Kim, 2019).

Moreover, financial development plays a vital role in improving and developing the quality of the environment by supporting renewable energy, scientific research, and growth in environmental sustainability. On the other hand, the financial sector supports many infrastructure development and manufacturing activities, which may lead to the stimulus that may stimulate Ecological Footprint (Baloch, Zhang, Iqbal, & Iqbal, 2019). This study is significant as it aims to investigate the relationship between financial development and renewable energy consumption on CO2 emissions and economic growth.

### Methods

The research depends on secondary sources to collect the data and information. The data is extracted from World Bank's World Development Indicators (WDI). The obtained data from this source helps to estimate the quantitative relationships between the variables from 2001 to 2017. The study uses a limited time frame and countries due to the availability of data and the absence of any missing data. The research is applied to 18 countries from the G20 Countries. The selected that are examined in this paper include Argentina, Australia, Brazil, China, France, Germany, India, Indonesia, Italy, Japan, Republic of Korea, Mexico, Russia, Saudi Arabia, South Africa, Turkey, the United Kingdom, and the United States. Two countries are excluded from the application, Canada and the European Union, due to the lack of data in the selected years.

The study uses the panel data vector autoregressive (PVAR) model to analyze the data. A panel of data consists of a group of cross-sectional units (people, households, firms, states, countries) that are observed over time. This model was developed by Love and Zicchino (2006) to increase the accuracy of the prediction. The model takes into account the effect of the change of time and calculate unobserved individual heterogeneity for the whole series (Love & Zicchino, 2006).

To test the validity of the data, the study uses many tests including Im-Pesaran-Shin unit-root test, Panel-data cointegration tests, Correlation matrix, Pooled OLS, Fixed Effect Model, Random Effect Model, Breusch and Pagan Lagrangian multiplier (LM) test, Hausman Test, Diagnostics Tests, heteroscedasticity test, and serial correlation test. The proposed panel VAR model is given by the following:

$$Y_{it} = \mu_{i+A(L)}Y_{it} + \alpha_i + \delta t + \varepsilon_{it}$$







## Results

The results of the PVAR model highlight the persistent impact of CO<sub>2</sub> emissions, in which high levels of CO<sub>2</sub> emissions today sustain higher levels of emissions in the future. Increased renewable energy consumption, on the other hand, results in a substantial reduction in CO<sub>2</sub> emissions. Furthermore, CO<sub>2</sub> emissions appear to be detrimental to financial development. This indicates that financial development may exacerbate environmental concerns by providing funding to heavy industries that can harm the environment through inefficient production practices. The findings also suggest that sound and efficient financial systems contributed significantly to future financial development. Economic growth and capital formation, as expected, have a positive impact on financial development. In regard of GDP growth determinants, results suggest that higher industrial activities in G20 countries appear to have a positive impact on economic growth. However, financial development is probably to have a detrimental impact on G20 economic growth. CO<sub>2</sub> emissions have a positive impact on renewable energy consumption, but financial development has a negative impact. Finally, capital formation is influenced positively by its lag values.

## Conclusions

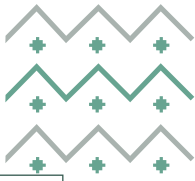
The study provides some policy recommendations. First, there is an urgent need to cut CO<sub>2</sub> emissions and replace renewable energy sources with traditional fossil fuels, which will benefit both future and current generations. Furthermore, it is essential to encourage green and energy-efficient economic activities by providing affordable finance to these industries. It is also necessary to switch to more energy-efficient industrial activities that are environmentally friendly to enhance their role in economic growth. Finally, policymakers must take serious measures to implement more efficient financial reforms in order to achieve financial stability and minimize disruptions in the G20 financial markets which consequently stimulate economic growth.

The study suggests further research to address significant issues that could not be covered in the current study. One of these challenges is to investigate the effects of real oil prices and trade openness on renewable energy consumption. One of the main shortcomings of this study is that it ignores the heterogeneity of the G20 countries. As a result, one potential extension of this study is to break the panel data into two subsamples based on the renewable energy share of total energy resources in order to examine the main determinants of economic growth and environmental deterioration for each subgroup. Future research may also include other institutional and sociodemographic variables, as well as other proxies of environmental degradation.

## References

- Baloch, M. A., Zhang, J., Iqbal, K., & Iqbal, Z. (2019). The effect of financial development on ecological footprint in BRI countries: evidence from panel data estimation. *Environmental Science and Pollution Research*, 26, 6199–6208.
- Hanif, I. (2018). Impact of economic growth, nonrenewable and renewable energy consumption, and urbanization on carbon emissions in Sub-Saharan Africa. *Environmental Science and Pollution Research*, 25, 15057–15067.
- Karimi, M. S., Ahmad, S., Karamelikli, H., Dinç, D. T., Khan, Y. A., Sabzehei, M. T., & Abbas, S. Z. (2021). Dynamic linkages between renewable energy, carbon emissions and economic growth through nonlinear ARDL approach: Evidence from Iran. *Plos one*, 16, e0253464.
- Park, J., & Kim, B. (2019). An analysis of South Korea's energy transition policy with regards to offshore wind power development. *Renewable and Sustainable Energy Reviews*, 109, 71–84.





## Renewable energy and employment in Saudi Arabia: Assessment and Prospects

Sylvain Cote, Strategy and Market Analysis, Saudi Aramco, + (966) 138732493,  
sylvain.cote@aramco.com

### Overview

Guided by Vision 2030, the Kingdom of Saudi Arabia has implemented a range of energy sector reforms to support the deployment of renewables, lower energy demand growth and decrease the energy intensity of the economy. While all important in enabling energy transition and curbing greenhouse gas emissions, renewable energy projects are particularly expected to lead to other positive outcomes such as the creation of local employment. Although job estimates vary greatly due to implicit differences in data collection and methodology, the bulk of studies show that jobs needed per unit of energy produced from renewable energy projects is significantly higher compared to conventional power projects. As the government aims to increase the share of renewables from the current less than 1.0% to 50% of power generation capacity by 2030, one would expect that higher labor intensity in the sector would translate into many jobs.

In the context of the Saudi labor market, however, common analytical approaches based on input-output tables or general equilibrium modeling can only give a partial view of the likely labor market outcomes. The relevant question is rather whom, among Saudis and non-Saudis, are most likely to benefit from job creation in this emerging sector. An examination of the evidence shows that long-entrenched occupational and sectoral biases, information asymmetry, and a shortage of adequate skills could limit this job creation potential for young Saudis.

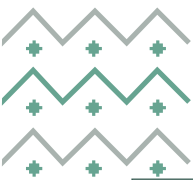
### Methodology

Using publicly available data, such as the General Authority for Statistics' labor force surveys, this paper employs descriptive statistics to assess the prospects of Saudi employment in the emerging renewable energy sector.

### Results

While renewable energy has the potential to create tens of thousands of jobs, the evidence shows that action may be required to unlock the job creation potential for Saudis in the sector – especially in a context where the labor supply of Saudis continues to grow. The continued preferences for training geared towards white-collar occupations, combined with a lack of vocational training, represent challenges for the employment of Saudi nationals – challenges which have their origins in issues such as occupational and sectoral biases, information asymmetry, and a shortage of adequate skills. More specifically:

1. A high degree of labor segregation subsists between nationals and non-nationals — with the former mostly working in the public sector (59% in 2020). In contrast, about 75% of expatriate workforce is currently (2020) employed in the sectors that are set to generate the bulk of renewable energy jobs — particularly manufacturing and construction.
2. This segregation also extends to gender. Data shows that Saudi labor force growth in the coming years will be more dependent on female workers, which are expected to grow at a faster rate than their male counterparts. However, Saudi females are more likely to be employed in lower paid, non-technical, administrative jobs in sectors such as public administration, education and health as well as



retail. Combined, these sectors currently account for more than 70% of total female employment. Resistance to physical and outdoor work adds to the challenge.

3. Education and training remain mis-aligned. The concentration of Saudis in the public sector is also reflected in its human capital endowment, with the majority of Saudis graduating with degrees in business, law and social sciences (60% in 2020). While technical and vocational qualifications are more relevant, less than 6.0% of males and less than 2.0% of females enroll in such programs. These figures contrast sharply with countries at the forefront of renewable energy development: 22% in Germany, 13% in Egypt, 9.0% in Morocco, and 8.0% in China.

### Conclusions

- Despite wide-ranging estimates, renewable energy projects in several countries have shown a strong potential for job creation — a welcome development given strong demographics in the Kingdom.
- A risk exists however that barriers, such as labor market occupational and sectoral biases, information asymmetry, and a shortage of adequate skills among young Saudis, could limit this opportunity.
- To alleviate these constraints, more efforts could be made to provide better labor market information, expand vocational training and work with industry to better target and develop skill needs.
- Even in the case of renewable energy projects having a modest impact for Saudi workers, its strategic potential in terms of skill and entrepreneurial development should still be considered.

### References

Al Yousif, M.A. (2019). "Renewable Energy Challenges and Opportunities in the Kingdom of Saudi Arabia." *Saudi Arabian Monetary Authority Working Paper*.

Böhringer, C., A. Keller, and E. van der Werf (2013). "Are green hopes too rosy? Employment and welfare impacts of renewable energy promotion." *Energy Economics*. 36, 277–285.

Cai, W., Wang, C., Chen, J., Wang, S. (2011). "Green economy and green jobs: myth or reality? The case of China's power generation sector." *Energy* 36, 5994–6003.

Marilyn A. Brown, Y. Li, and A. Soni (2020). "Are all jobs created equal? Regional employment impacts of a U.S. carbon tax." *Applied Energy*, Volume 262, 15 March 2020.

International Renewable Energy Agency and International Labor Organization (2021). *Renewable Energy and Jobs – Annual Review 2021*. Abu Dhabi, UAE.

International Renewable Energy Agency (2019a). *Renewable Energy Market Analysis: GCC Region*. Abu Dhabi, UAE.

. (2019b). *Gender perspective*. Abu Dhabi, UAE.

. (2017). *Renewable Energy and Jobs – Annual Review 2017*. Abu Dhabi, UAE.

. (2013). *Renewable Energy and Jobs – Annual Review 2013*, Abu Dhabi, UAE.

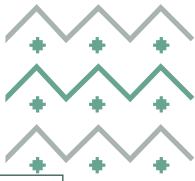
Ministry of Energy (2019). *National Renewable Energy Program*. Renewable Energy Project Development Office (REPDO).

Pollin, J. Heintz, and H. Garrett-Peltier (2009). "The Economic Benefits of Investing in Clean Energy." Department of Economics and Political Economy Research Institute (PERI), University of Massachusetts, Amherst.

Rutovitz, J. and S. Harris (2012). *Calculating Global Energy Sector Jobs: 2012*. Methodology. Institute for Sustainable Futures, UTS, pp. 1 – 52.

Wei, M., S. Patadia and D.M. Kammen (2010). Putting renewables and energy efficiency to work: How many jobs can the clean energy industry generate in the US? *Energy Policy* 38 (2010) 919–931.





## Economic and Energy Impacts of Saudi's Giga Tourism Projects

David Omom, Saudi Aramco, +966 13 873 5801, [david.omom@aramco.com](mailto:david.omom@aramco.com)

Sijesh Aravindhakshan, Saudi Aramco, +966 13 873 3887, [sijesh.aravindhakshan@aramco.com](mailto:sijesh.aravindhakshan@aramco.com)

Laila Alabdrabalnabi, Saudi Aramco, +966 13 872 3424, [laila.alabdrabalnabi@aramco.com](mailto:laila.alabdrabalnabi@aramco.com)

### Overview

As part of Vision 2030, Saudi Arabia has committed to diversifying its economy away from hydrocarbons. A central pillar of this effort will be the transformation of the Kingdom into a leading tourism hub. This entails increasing the number of visitors from 20 million in 2019 to 100 million by 2030 and the GDP contribution of tourism to 10% from the current 3.0%.

To help achieve these ambitious targets, the Kingdom has embarked upon developing seven giga tourism projects across the country, which are expected to come online over the next decade. Spearheading this effort, the Public Investment Fund (PIF) is developing five of the seven projects, namely: the Red Sea Resort, Amaala, NEOM, Qiddiya and Soudah. The Royal Commission for Al-Ula (RCU) and the Diriyah Gate Development Authority (DGDA) are managing Al-Ula and Diriyah projects. Only NEOM's tourism projects are considered in the paper, not the full city targets. Along with these projects, the government also aims to expand airport capacity to 330 million passengers and add 500,000 new hotel rooms.

### Methodology

The study employs a three-tiered analytical framework. First, covering a 30-year period to 2050, an investment/financial model for each project is developed. For each project, this model assesses the impact of detailed capital spending (hotels, leisure facilities, shopping and dining, real-estate for sale etc.) and associated infrastructure investments as well as direct employment footprint. In the operational phase of the projects, the model estimates revenues from hotels, dining, shopping, sports and other leisure activities and real estate sales as well as the associated operating costs and EBITDA margins.

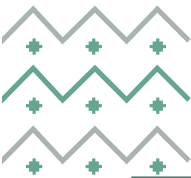
A second model integrates these outcomes with a granular input-output table of Saudi Arabia to estimate gross value added and employment contributions. A third model based on a benchmark of similar but best-in-class projects globally, extends the analysis to assess the energy footprint and avoided emissions from the greener and more sustainable consumption patterns adopted by the projects. The results are provided at an aggregate and project or unit specific level.

Data source: Most of the data/information is obtained from public sources, including PIF press releases and a detailed benchmarking of similar assets (hotels, Formula 1 tracks, etc.) globally. We also make extensive use of the Middle East Economic Digest (MEED) project database for capital spending and a granular input-output table of Saudi Arabia which has been developed by Saudi Aramco.

### Results

Supported by an investment of \$64 billion, all seven projects are expected to generate an annual average of \$22.4 billion (\$13.7 billion directly) in GDP and 240,000 jobs (67,000 jobs directly) over the construction and operation phases of the businesses until 2050. The projects are expected to be profitable with an

Saudi Aramco: Company General Use



operational margin of \$1.6 billion. However, they are likely to struggle in fully recovering the large capital expenditures on direct facilities and associated infrastructure spending during the 30-year period to 2050.

Combined, the projects are projected to consume around 0.4 TWh of electricity at their peak operations. Three projects are being designed to be fully green (Red Sea, Amaala, NEOM). These will consume 0.2 TWh of energy and avoid considerable emissions relative to the grid-sourced electricity.

The projects are not however without risks which include their large scale, location, types of products (premium-heavy), insufficient differentiation (particularly between NEOM, Al Ula, Red Sea and Amaala) and insufficient number of trained Saudi workforce.

Finally, we acknowledge some differences with the publicly reported impacts availed by PIF. Our use of publicly available data and PIF's reporting of high-level headline impacts means that a full reconciliation is not possible. In addition, our energy footprint assessment excludes embedded energy in water consumption; LPG used as a supplement in cooking and heating and diesel consumed during the construction phase which are covered in a future revision of the paper.

### Conclusions

Saudi Arabia's giga projects are flagship showcase drivers for an ambitious tourism sector. Over the 30-year period to 2050, on average, these projects are expected to create 240,000 jobs and generate over \$22.0 billion in GDP annually. Overall electricity requirements of the seven projects are estimated at 0.4TWh. Crucially, the greenhouse gas emissions footprint of the projects is expected to be relatively modest as three projects will be fueled by 100% green energy. Together, these projects offer a strong start to delivering on the tourism ambition and diversifying the Kingdom's economy away from hydrocarbons.

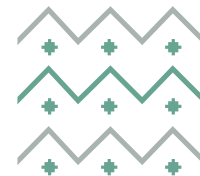
### References

- Saudi Aramco (2015). Input-Output Model
- MEED (2021). <https://www.meedprojects.com/> - MEED is a proprietary online service providing in-depth project tracking platform in the region.
- World Tourism Organization (2020). Compendium of Tourism Statistics dataset (Electronic). Saudi Arabia Basic Indicators Country Report
- GOV.SA (2021), Tourism Strategy in Saudi Arabia, <https://www.my.gov.sa/wps/portal/snp/aboutksa/tourism>
- General Authority for Statistics (2020), Chapter 17. Tourism, Entertainment and Sports; *55th Statistical Yearbook: 2019*
- Argaam (2021). Saudi Arabia to add over 500,000 hotel rooms in next five years, says minister. May 1, 2021. <https://www.argaam.com/en/article/articledetail/id/1463955>
- Jones Lang LaSalle (2021). The KSA Real Estate Market Research, Q1 2021

Saudi Aramco: Company General Use







[PAPER/POSTER TITLE]

**The relationship between economic growth and CO<sub>2</sub> emissions in Saudi Arabia: An empirical analysis of the environmental Kuznets curve**

Rawaa Ahmed Omar Al-Afari, Department of Economics, School of Business Administration, King Faisal University, 0552813352, Rawaa.alafari@gmail.com  
 Oussama Zaghoud, Department of Economics, School of Business Administration, King Faisal University, 0135896221, ozaghoud@kfu.edu.sa

**Overview**

The connection and interactions between economic development and environmental degradation have been a topic of many studies over the recent past. Saudi Arabia has seen an increased amount of emissions of carbon dioxide as a result of continued economic growth. The relationship between these variables can be tested using the environmental Kuznets curve (EKC). The Environmental Kuznets curve (EKC) states that at first, there exists a direct proportion relationship between economic development and environmental pollution (de Bruyn et al., 1998). After achieving a certain level of income, the relationship becomes inverted or reversed. In our current study, we try to examine the relationship between pollutant emissions and economic growth for an open developing country, Saudi Arabia, during the period 1980–2019. This study is made on basis of the environmental Kuznets curve hypothesis (EKC), using time series data and cointegration analysis. We use Carbon dioxide (CO<sub>2</sub>) as the environmental indicator and GDP as the economic indicator.

**Methods**

In our empirical analysis, we use per capita carbon dioxide (CO<sub>2</sub>) as the environmental indicators (measured in metric tons), and per capita GDP in constant 2010 US dollars as the economic indicator. The pollutant emissions is chosen according to their environmental relevance and because it is available on a national basis and for the longest time period. The CO<sub>2</sub> emissions are those stemming from the burning of fossil fuels (including solid fuel, liquid fuel and gas flaring) and the manufacture of cement. The CO<sub>2</sub> emissions cause problems on a global scale, which are classified as one of the main driving forces behind global warming today. All data used in this study covering the period 1980-2019. Per capita GDP and per capita CO<sub>2</sub> emissions are taken from the World Bank's *World Development Indicators* (2021). The objectives of our empirical estimation are to examine how the variables are related in the long-run and to assess the dynamic causal relationship between these variables. In line with these objectives, our methodological approach in this paper is structured as follows: First, we test for stationarity in the time series for all the variables using three unit root tests: the augmented Dickey-Fuller (ADF) test (Dickey and Fuller, 1979), the Phillips-Perron (PP) test (Phillips and Perron, 1988) and the Kwiatkowski-Phillips-Schmidt-Shin (KPSS) test (Kwiatkowski et al., 1992). The second step is to test for cointegration using the Johansen technique (Johansen, 1995), which is carried out in a context of a vector autoregression (VAR) model. Whether or not the variables included in the VAR model are cointegrated has implications for the form of that model and for the type of causality test that is appropriate. If the Johansen tests support the conclusion that the variables are not cointegrated, then causality tests must be based on a VAR model in first differences. If, however, the variables are cointegrated, then causality tests should be based on an error correction model (ECM). So, the third step is to test for causality by employing the appropriate types of causality tests.

**Results**

According to the EKC hypothesis, the long-run relationship between economic growth and environmental degradation can be expressed as a logarithmic cubic function of the income, given by:

$$\ln P_t = \alpha_0 + \alpha_1 \ln Y_t + \alpha_2 (\ln Y_t)^2 + \alpha_3 (\ln Y_t)^3 + \varepsilon_t \quad (3)$$

Eq. (3) allows us to test the various forms of environmental-economic relationships;  $\alpha_1 > 0, \alpha_2 < 0$  and  $\alpha_3 > 0$  reveals an N-shaped relationship;  $\alpha_1 < 0, \alpha_2 > 0$  and  $\alpha_3 < 0$  reveals an inverse N-shaped relationship;



$\alpha_1 < 0, \alpha_2 > 0$  and  $\alpha_3 = 0$  reveals a U-shaped relationship;  $\alpha_1 > 0, \alpha_2 < 0$  and  $\alpha_3 = 0$  reveals an inverse U-shaped relationship, representing the EKC hypothesis, the turning point of the EKC is computed by  $\hat{\tau} = \exp(-0.5\hat{\alpha}_1 / \hat{\alpha}_2)$ ;  $\alpha_1 > 0$  and  $\alpha_2 = \alpha_3 = 0$  reveals a monotonically increasing linear relationship;  $\alpha_1 < 0$  and  $\alpha_2 = \alpha_3 = 0$  reveals a monotonically decreasing linear relationship.

We use Carbon dioxide (CO<sub>2</sub>) as the environmental indicator ( $P_t$ ) and GDP as the economic indicator ( $Y_t$ ). Our primary results (our empirical research has not finished yet) show that there is a long-run cointegrating relationship between the per capita carbon dioxide (CO<sub>2</sub>) emissions. Actually, a monotonically increasing relationship with GDP is found more appropriate for CO<sub>2</sub> emissions. Therefore, our empirical findings do not support the hypothesis of an inverted U-shaped EKC for CO<sub>2</sub> emissions in Saudi Arabia. However, the causality results show that the relationship between income and CO<sub>2</sub> emissions is one of unidirectional causality emissions with income causing environmental changes and not vice versa, both in the short-run and long-run. This implies that emission abatement policies and more investment in mega green projects will not hurt economic growth. It could be a feasible policy tool for Saudi Arabia to achieve its sustainable growth in the long-run.

## Conclusions

In our current paper we examine the relationship between pollutant emissions and economic growth for an open developing country, Saudi Arabia, during the period 1980–2019. This study is made on basis of the environmental Kuznets curve hypothesis (EKC), using time series data and cointegration analysis. We use Carbon dioxide (CO<sub>2</sub>) as the environmental indicator and GDP as the economic indicator. Our results show that there is a long-run cointegrating relationship between the per capita carbon dioxide (CO<sub>2</sub>) emissions. Actually, a monotonically increasing relationship with GDP is found more appropriate for CO<sub>2</sub> emissions. Therefore, our empirical findings do not support the hypothesis of an inverted U-shaped EKC for CO<sub>2</sub> emissions in Saudi Arabia. However, the causality results show that the relationship between income and CO<sub>2</sub> emissions is one of unidirectional causality emissions with income causing environmental changes and not vice versa, both in the short-run and long-run. This implies that emission abatement policies and more investment in mega green projects will not hurt economic growth. It could be a feasible policy tool for Saudi Arabia to achieve its sustainable growth in the long-run.

## References

- Akbostancı, E., Türüt-Aşık, S., & Tunç, G. İ. (2009). The relationship between income and environment in Turkey: is there an environmental Kuznets curve? *Energy policy*, 37, 861–867.
- Ang, J. B. (2007). CO<sub>2</sub> emissions, energy consumption, and output in France. *Energy policy*, 35, 4772–4778.
- Belloumi, & Alshehry. (2020).
- Belloumi, M., & Alshehry, A. (2020). The impact of international trade on sustainable development in Saudi Arabia. *Sustainability*, 12, 5421.
- Bradford, D. F., Fender, R. A., Shore, S. H., & Wagner, M. (2005). The environmental Kuznets curve: exploring a fresh specification. *Contributions in Economic Analysis & Policy*, 4, 1–28.
- Brajer, V., Mead, R. W., & Xiao, F. (2008). Health benefits of tunneling through the Chinese environmental Kuznets curve (EKC). *Ecological Economics*, 66, 674–686.
- Cole, M. A. (2004). Trade, the pollution haven hypothesis and the environmental Kuznets curve: examining the linkages. *Ecological economics*, 48, 71–81.
- Cole, M. A., & Elliott, R. J. (2003). Determining the trade–environment composition effect: the role of capital, labor and environmental regulations. *Journal of environmental economics and management*, 46, 363–383.
- Day, K. M., & Grafton, R. Q. (2003). Growth and the environment in Canada: an empirical analysis. *Canadian Journal of Agricultural Economics/Revue canadienne d'agroeconomie*, 51, 197–216.
- Dinda, S. (2004). Environmental Kuznets curve hypothesis: a survey. *Ecological economics*, 49, 431–455.
- Egli, H. (2004). The environmental Kuznets curve-evidence from time series data for Germany.
- Omri, A., Euch, J., Hasaballah, A. H., & Al-Tit, A. (2019). Determinants of environmental sustainability: evidence from Saudi Arabia. *Science of the Total Environment*, 657, 1592–1601.
- Raggad, B. (2018). Carbon dioxide emissions, economic growth, energy use, and urbanization in Saudi Arabia: evidence from the ARDL approach and impulse saturation break tests. *Environmental Science and Pollution Research*, 25, 14882–14898.
- Toumi, S., & Toumi, H. (2019). Asymmetric causality among renewable energy consumption, CO<sub>2</sub> emissions, and economic growth in KSA: evidence from a non-linear ARDL model. *Environmental Science and Pollution Research*, 26, 16145–16156.



## A Just Energy Transition for All? The Invisible Case of Women

**Manal Shehabi**, St. Antony's College-Oxford University; SHEER Research & Advisory Ltd, +447534209595, [manal.shehabi@sant.ox.ac.uk](mailto:manal.shehabi@sant.ox.ac.uk)

**Garima Rastogi**, Wadham College-Oxford University; SHEER Research & Advisory Ltd, +447767814558 [garima.rastogi@wadham.ox.ac.uk](mailto:garima.rastogi@wadham.ox.ac.uk)

### Overview

As a concept, Just Transition was an early trade union demand that has now become a mainstream policy tool applied by international institutions and treaties. It has become increasingly popular in recent years in the context of climate change adaptation and mitigation policies. While these policies aim at limiting the rise in global temperature through reducing greenhouse gas (GHG) emissions and the ensuing climate change, they will naturally affect industries and, therefore, labour. Just transition has come to be known as “maximizing the social and economic opportunities of climate action, while minimizing and carefully managing any challenges – including through effective social dialogue among all groups impacted, and respect for fundamental labour principles and rights” (ILO, n.d.). In the context of just transition, the concept of just energy transition has emerged to address specifically just transition implications of the energy transition, especially in the context of fossil fuel dependent economies. Energy transitions are costly, especially for hydrocarbon dependent economies as they involve various trade-offs between socioeconomic development and energy diversification projects, requiring the implementation of just transition policies (Shehabi, 2022). At the same time, a just energy transition is urgent but indispensable and, thus, requires rapid economic, technological, and social transformation as well as large fiscal and financial costs (Shehabi, 2022; Shehabi & Rastogi, 2022). Despite the huge role fossil-fuel dependent economies are likely to play in any just energy transition on a global scale, much of this literature focusses on the global north. Additionally, while existing research on just energy transition remains in its early stages, the focus on the context of gender or other considerations is almost lacking (Shehabi & Rastogi, 2022) even though women and other groups tend to be among the most impacted by climate change and mitigation measures (UNFCCC, 2022). While women have a much stronger presence in renewable energy than in the traditional energy sector, they still constitute only 32% of the overall renewable energy workforce and, thus, remain underrepresented (IRENA, 2021). The impacts of climate change, and policies with a gender-neutral approach to mitigate these impacts, may exacerbate the barriers faced by women working in the energy sector. A just transition is key in minimising impacts of mitigation measures on people in vulnerable situations and can reduce occupational gender stereotypes that prevent women from benefiting from the economy (ILO, 2022).

In this context, this paper builds upon previous work by the authors on just energy transition by zooming in on women in the context of just energy transition.

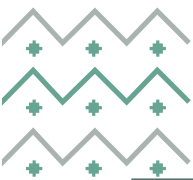
### Methods

The paper undertakes a qualitative assessment for the gaps that exist in the literature on women in the context of just energy transition and provides both policy recommendations as well as avenues for future research. The paper then identifies key areas that affect women specifically in the context of the energy transition.

### Results

The key result of the paper is that, first, there is dearth in studies at the intersection of gender and just energy transition as well as a dearth of studies on effects of the energy transition on women. Our result confirms conclusions that existing research on mitigation policies is “preoccupied with techno-economic transformations” that are perceived to be gender neutral (Michael et al., 2020). Second, indeed, women are impacted in the context of the energy transition both as workers in the fossil fuel industries as well as energy consumers, domestic carers or other occupations. Yet the nature of the impacts of the energy transition in different across different industries and geographic areas will affect women differently. There is evidence that women in energy-poor areas are positively





impacted by the energy transition, while in other areas where they work in fossil fuel industries are negatively impacted. The paper relies on data available in the public domain to evidence these results.

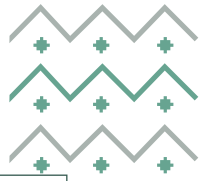
## Conclusions

The just energy transition is an indispensable means to a successful energy transition, but the latter has to be inclusive of all and has to extend beyond direct effect of labour. Women are specifically impacted by the energy transition in various capacities and, therefore, gender-specific policies must be designed within the larger context of the just energy transition policies. In fossil-fuel producing countries, just energy transition policies must be accompanied by skills development and social protection policies to ensure women's safety and well-being as well as provision of adequate conditions for women's engagement in the labour market and energy access. Furthermore, sex-disaggregated data must be more readily available to better understand the role played by women in the energy sector, and its sub-sectors, for these policies to be better targeted. The concluding section of the paper identifies various areas for future policy and research focus that are distinguish between geographic areas and sectors.

## References

- ILO (n.d.). *Just Transition: Frequently Asked Question*.
- ILO (2022). *Just transition: An essential pathway to achieving gender equality and social justice*.  
<https://www4.unfccc.int/sites/SubmissionsStaging/Documents/202204141910---ILO%20submission%20-%20Just%20transition%20-%20An%20essential%20pathway%20to%20achieving%20gender%20equality%20and%20social%20justice.pdf>
- IRENA (2021). *Renewable Energy and Jobs: Annual Review 2021*. [https://www.irena.org/-/media/Files/IRENA/Agency/Publication/2021/Oct/IRENA\\_RE\\_Jobs\\_2021.pdf](https://www.irena.org/-/media/Files/IRENA/Agency/Publication/2021/Oct/IRENA_RE_Jobs_2021.pdf)
- Michael, K., Shrivastava, M. K., Hakhu, A., & Bajaj, K. (2020). A two-step approach to integrating gender justice into mitigation policy: examples from India, *Climate Policy*, 20:7, 800-814, DOI: 10.1080/14693062.2019.1676688
- Shehabi, M. (2022). *Just Energy Transition in the Context of the Middle East and North Africa*. Presentation to the UNFCCC Workshop and MENA Climate Week, Dubai (April).
- Shehabi, M. & Rastogi, G. (2022, forthcoming). *Just Energy Transition: Overview, Opportunities, and Challenges*.
- UNFCCC (2022). *Activity 9 Paper for the KCI 6<sup>th</sup> Meeting*.





Energy, economic development, and climate change

## Biogas as clean energy alternative for rural poor at West Kordofan-Sudan

Banazeer Abdel-Mahmoud<sup>1</sup>, Muna Ahmed<sup>2</sup>

<sup>1</sup>Agriculture Technological Transfer Society,

Email: [banazeersd@gmail.com](mailto:banazeersd@gmail.com) Telephone:

+249 960133621

<sup>2</sup>Institute of Environmental Studies, University of Khartoum

Email: [munamm789@yahoo.com](mailto:munamm789@yahoo.com), Telephone: +249 912149607

### Overview

Biogas technology helps improve in the livelihoods of poor rural people and contributes to the reduction of greenhouse gas emissions. The use of biogas helps minimize carbon emissions caused by burning fuel wood and by natural decomposition of organic waste. This alternative form of energy also reduces the use of fossil energy. It helps improve sanitation conditions because cattle dung is no longer burned to generate power but is channeled into biogas digesters. Biogas plants also produce organic waste that is dried and used as fertilizer (Biogas for Africa, 2007).

### Methods

The experiment was done in Kurdofoan region situated in the central part of Sudan extending from 9.50 to 16.40oN latitudes and from 27.30 to 32.25oE longitudes. The region covers an area of approximately 380,000 km<sup>2</sup>, representing 24% of the total area of the country. The total population of the region is about 3.25 million comprising 15% population of Sudan. Urban population constitutes 15%, nomads 20% and the sedentary rural population constitutes 65% of the total population.

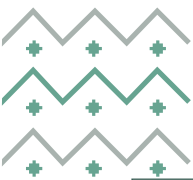
A questionnaire was prepared to cover 361 households. The purpose of the questionnaire was to collect data and information from the households about types of fuel used and purposes of using the fuels. Other information included distance travelled to collect fuel wood, time to prepare the meals. Kitchens were visited to investigate the environment in which women were working while preparing the food, time spent and utensils cleanness.

First visit covered kitchens in households where the cooking utensils, types of fuel used and air quality environment were investigated. Second visits were carried out to investigate the effect of biogas unit implementation.

7 biogas units were installed in 7 households in the village of Kamas Aldonkey, and another 8 biogas unite were installed in the village of Kamas Hagar at western Sudan. The unit is a fixed Chinese model which consists of an underground brick masonry compartment (fermentation chamber) with a brick dome, concrete or prefabricated plastic dome on the top for gas storage. The biogas unit is a fixed dome Chinese unit of a volume of 3.2 m<sup>3</sup>. It is designed to give 1.6 – 1.8 cm<sup>3</sup> methane gas. The calculations were done as follows







## Results

Fetching of fuel wood was done mainly by walking on foot (43%), riding donkeys (30%), and using carts (27%). Difficulties for fuel wood collection was mainly related to distance travelled (57%), cutting wood and transportation (17%), scarcity of fuel wood (13%), high price (9%) and others (4%). First visit revealed that all households used the traditional method of cooking with a three-stone cooking fire. The impact of biogas technology showed that the time taken to collect fuelwood was reduced to zero. Time spent to cook main meals is reduced from 2-3 to ½ hour for breakfast, from 2 to 1 hour for lunch and from 1 ½- ¼ hour for dinner and too few minutes for tea. Money spent for purchasing wood fuel or charcoal was reduced to zero. Women and children are now enjoying healthier conditions.

It could be shown that a single bio digester can reduce 4 tCO<sub>2</sub> per year. Calculations were done as follows.

By = Quantity Appliance \* Ny \* Usage Rate \* 0.95

$$= 4.945 * 15 * 0.8 * 0.95 \text{ t/year}$$

$$= 56 \text{ t/year}$$

$$= 56 * 81\% * 0.015 * 81.6 \text{ tCO}_2/\text{year}$$

$$= 55.5 \text{ tCO}_2/\text{year of emissions could be reduced from a single biodigester}$$

## Conclusions

Installation of biogas units can contribute to replace fossil fuels, thus reducing the emission of GHGs and other harmful emissions; by tapping biogas using it as a source of energy, harmful effects of methane on the biosphere are reduced. Keeping manure and waste in a confined area and processing in the digester reduces the amount of pollutants in the immediate environment and increases sanitation. Households no longer need to extract wood for cooking, hence can reduce deforestation levels where people heavily rely on wood fuel. The sludge remaining after digestion is a good fertilizer, increasing land productivity (and farm incomes). The release of methane is avoided thus contributing to climate mitigation. A single, small scale bio digester reduces between 3 and 5 tCO<sub>2</sub>-eq/year.

## References

Biogas for Africa 2007. Biogas for better Life, An African Initiative, available online at <http://www.biogasafrica.org/images/stories/downloads/business%20plan.pdf>

Karekezi S. 1994. Renewable energy technologies as an option for a low-carbon energy future for developing countries: case examples from Eastern and Southern Africa.

Amigun B., Sigamoney R., von Blottnitz H. 2008. Commercialization of biofuel industry in Africa: A review. *Renewable and Sustainable Energy Reviews*, 12:690-711.

Akinbami J.-F.K., Ilori M.O., Oyebisi T.O., Akinwuni I.O., Adeoti O. 2001. Biogas energy use in Nigeria: current status, future prospects and policy implications. *Renewable and Sustainable Energy Reviews*, 5:97-112.

[www.unep.org/sudan](http://www.unep.org/sudan) accessed August 2015





## ***ROLLING-OUT BIOGAS PRODUCTION TO EMPOWERING RURAL WOMEN IN SUDAN***

Hazir Farouk, Associate Professor -Sudan University of Science and Technology, 00249-912297962, [biodieselgroup11@gmail.com](mailto:biodieselgroup11@gmail.com)  
Andrew Lang, Senior Consultant-World Bioenergy Association, 0061-409977048, [andrewlang001@bigpond.com](mailto:andrewlang001@bigpond.com)

### **Overview**

Over the past few decades, Sudan's energy profile has evolved significantly, and the demand for energy has significantly multiplied to the extent that the gap between the production and demand has started to rapidly widen. Population growth and urban spread in the main towns has tremendously increased as a result of improved economic activities, and enhanced infrastructure including electricity supply and communication/media systems. As a consequence, the growth in demand for energy has surpassed the supply in term of quantities and energy type. Biomass in the form of firewood and charcoal consistently accounts for the largest share of primary energy supply in Sudan, at almost 60%. This use of firewood and charcoal is unsustainable and is contributing to the very high level of deforestation in Sudan. However, this can be quite quickly changed by switching to other available and presently relatively unutilized biomass forms, and production of biogas from anaerobic digesters can play a significant role in this.

Biogas from anaerobic digestion is a potentially major source of energy in regions where housed livestock and other feedstock materials are present, and where the other conventional sources of energy (e.g. LPG and electricity) are not readily available. Installation of smaller-scale household biogas digesters is advanced in some African countries, with Kenya, Ethiopia, Cameroon and Uganda being among these. The driving priorities are similar to those in Sudan: reduction of deforestation, utilization of animal manures and food waste, reducing the negative health impacts of smoke in the kitchen or cooking area particularly on women, and capturing the benefits of better health and more time available for other economic activities.

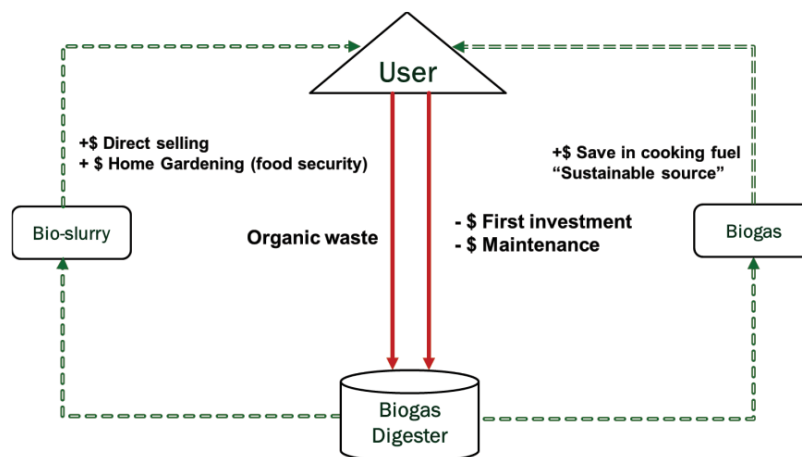
The biogas technology is considered as an ancient technique, which was introduced to Sudan beginning in the 1970s, and its development was driven by the activities and experiments in the laboratories of research centers and colleges and at various universities, and units were successively set up thereafter at different times and places. These included homes, schools, camps, hospitals and prisons, for the purpose of cooking, lighting, cooling, and for operation of internal combustion engines (ICEs). Despite the research and investment in Sudan in the field of biogas production, the initial installations were not entirely satisfactory, with a diminishing of the number of units established in recent years for different reasons: technical problems (especially in the operation), gas storage, maintenance and after sales services; the high initial cost of biogas digesters, especially for households; lack of knowledge on the technology – despite the efforts of some national NGOs on promoting the technology, its uses and products; and absence of a business model that suited different market segments.

The objective of this work is to present a developed business model of anaerobic digestion of the wet organic waste forms of biomass that are sustainably and economically available at the household level. The main products of this anaerobic digestion process are biogas, which is a combustible gas consisting primarily of methane and carbon dioxide, and the digestate, which is the decomposed substrate after the anaerobic digestion process.

### **Methods**

This work is a proof-of-concept project that aimed to gain experience in technology, economy and management-related issues of a newly-developed, mobile biogas technology that includes a biogas storage container, which allows surplus biogas produced from a system to be shared with or sold to other households. This biogas system is a low-tech plug flow system for the production of biogas as cooking fuel for household. It consists of a 2 m<sup>3</sup> to 3.5 m<sup>3</sup> flexible bag connected to an inlet at one end, an overflow or digestate outlet pipe at the other end, and a gas outlet in the upper surface. The digester is placed inside a greenhouse or shadehouse for protection, and solar heating in winter with the anaerobic digester comes with a separate gas storage bag which is filled through pressure equalization. It can be easily carried and connected to the cooking stove. The gas is forced out of the portable gas storage by weighting it using some form of external loading. The digestate produced, is for use as a fertilizer in home gardening. The figure below shows the business model that introduced to the household.





The social business model for digester user

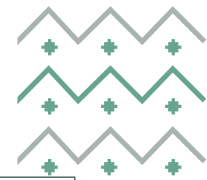
## Results

The use of biogas in this project as a cooking fuel has replaced the use of firewood and charcoal in the household. The principal listed benefits and impacts below not only refer to the implementation of this pilot project, but also to the long-term effects of a larger scale implementation of this concept.

1. Using of biogas as a cooking fuel replaced the use of firewood and charcoal. Thus, reduced the workload of women and girls to collect wood "which also consume time"; and reduced time spent in cooking. These reduced the burden on women to do household chores and gives them time to focus on other economically productive activities.
2. Cooking with biogas significantly reduced indoor air pollution, and relatively lower emissions levels, which will have a direct positive impact on health by reducing the risk of respiratory diseases caused by indoor air pollution due to smoke from open fires.
3. The digestate residue "bio-slurry" produced is a natural fertilizer for agriculture and home gardens. It improved the growth of crops and vegetables for consumption (so added food security) and sale (so generation of additional income).
4. With a short pay-back period, users of biogas will have access to a free and clean source of energy for the remaining lifespan of the technology. In households where fuel for cooking is purchased, the household will save this money.

## Conclusions

Sudan shares some significant common factors with many other countries which have developed a significant energy production using biogas from anaerobic digestion. These common factors include: the high volume of putrescible wastes produced by different communities and industries, the daily struggle of women and children to collect wood for cooking in rural areas, the large numbers of rural villages and small cites which are without access to LPG and are not connected to the main electricity grid, the high deforestation rate due to cutting wood for fuel, and the thousands of graduates who could be gainfully employed in developing this option, and who presently do not have jobs or who are working in menial jobs paying low income. Sudan can be counted as one of those countries which have abundant sources for biogas production and where this technology can have a great contribution in solving energy problems in rural areas and within the country generally. The mobile biogas system introduced in this project has proved elsewhere its viability for use by rural women. Also demonstrated elsewhere is that the use of biogas digesters means significant savings in time and money previously required to get cooking fuel, and that they empower rural women through the use of biogas for clean cooking, and the sale of surplus biogas to other households in the neighbourhood, as well as improving the crop productivity in home gardens. Overall, it has been shown that this use of household anaerobic digesters can help build a profitable, sustainable and inclusive cooking energy sector that helps people, planet and economy to thrive. The installation of biogas systems for producing clean cooking fuel contributes directly to many of the UN Sustainable Development Goals, including those directed at achieving no poverty, zero hunger, good health and well-being, gender equality, decent work and economic growth, and climate action. But, foremost among the SDGs, sustainable biogas production will significantly support the just and inclusive energy transition.



## OCCUPATIONAL CHOICE AND ENERGY ACCESS – ELECTRICITY FOR MORE AND BETTER JOBS

Ulrike Lehr, World Bank Group, Jobs Group, 1-202-3753833, ulehr@worldbank.org

### Overview

Access to affordable and clean energy is considered essential for development and is part of the 17 Sustainable Development Goal. As such, it is measured and monitored in the SDG7 Tracking report, jointly issued by the SDG7 custodians<sup>1</sup>. The current status is mixed. Access to electricity, indicator 7.1.1 rose markedly between 2010 and 2020, from 83 percent to 91 percent (SDG Tracking 2022). Last year contributed less to this gain than earlier years. The SDG7 Tracking report projects, that at current rates of progress, the world will reach only 92 percent electrification by 2030.

The impact of energy access on development, though intuitively understood, is hard to measure, as is its impact on more and better jobs. The literature to this regards is scarce and inconclusive, and the few empirical results show, depending on the measurement method positive to neutral effects. Increasingly the literature agrees that mere connection of a village or a household to a grid or mini-grid will not automatically lead to large development effects.

The WBG has developed a Multi-Tier-Framework (MTF) based on household surveys, providing a detailed picture of the quality of energy, the affordability, health aspects and energy use for household appliances, public services and economic activities, including questions regarding productive use.

This paper uses the respective data set to analyze how the probability of taking up non-agrarian economic activity is influenced by access to electricity. It follows an idea by (Khurana and Sangita 2022), and extends it to estimating the probability not only to take on non-agrarian activities, but specific economic activities in different sectors. In the case of Nigeria, for instance, the probability to work in a self employed non-farm business, is less strongly influenced by energy access than the probability to work in salaried non-farm businesses as an employee. Hence electricity access seems to enhance the quality of jobs, too. Also, regressing revenues from said economic activities or incomes, energy access in the Nigerian case shows positive and significant parameters. The model is set for the Nigerian case study, but the analysis is currently extended to more African states, such as Niger, Zambia and Kenya. As comparison can Nepal and Honduras serve, for which the extended survey data already have been published.

Taking household characteristics, energy access, land ownership and access to loans into the estimation helps identify entry points for policy support of productive use of energy to make energy access a true contributor to development and growth.

### Methods

Access to clean and affordable energy needs an indicator to monitor progress and include it in impact analysis of developing policies. The IEA defines energy access as "a household having reliable and affordable access to both clean cooking facilities and to electricity, which is enough to supply a basic bundle of energy services initially, and then an increasing level of electricity over time to reach the regional average". A basic bundle of energy services means, at a minimum, several lightbulbs, task lighting (such as a flashlight), phone charging and a radio.

The WHO and the World Bank have developed a more finely grained approach, acknowledging that more granular household energy data can facilitate energy policy analysis and energy infrastructure (Bhatia and Angelou 2015). For energy access to contribute to development, energy supply must be reliable and suffice for productive engagements and community facilities. Hence, data collection for this multi-tier framework (MTF)<sup>2</sup> based on additional questions to be integrated in national household surveys (SDG7 Custodians 2022) supports analysis on access to energy, productive engagements, income, productivity, and employment.

In the following, this dataset is used to identify the probability of an individual participating in entrepreneurial activity as dependent on various factors following (Nagler and Naude 2016) or later (Khurana and Sangita 2022). (Nagler and

<sup>1</sup> IEA, IRENA, the United Nations Statistics Division, the World Bank and the WHO

<sup>2</sup> Access to energy for community infrastructure (such as schools, health facilities, and government offices) can lead to substantial improvements in service delivery, human capital, and governance. The MTF specifies this in a chapter on Access to Energy for Productive Engagements Productive uses. They are defined as uses that increase income or productivity and can be seen as value-adding activities. The country reports published thus far can be found under (<https://mtfenergyaccess.esmap.org/publications>) for Cambodia, Ethiopia, Myanmar, Nepal, Rwanda, São Tomé and Príncipe and Zambia.





Naude 2016) apply discrete choice, selection model and panel data estimators to data from the Living Standards Measurement Study—Integrated Surveys on Agriculture from Ethiopia, Niger, Nigeria, Malawi, Tanzania, and Uganda, this paper uses the MTF data collection in North-West Nigeria occurred from September 2017 to March 2018 (ESMAP 2018) A total of 3,668 households (1,833 in rural and 1,835 in urban areas) are equally split between urban and rural areas, from all the seven states of the North-West Nigeria. North-West Nigeria is one out of six geopolitical zones in the country with both economic development and access to energy lower than those in southern zones of Nigeria (World Bank 2019).

Occupational choice is reflected in three categorial variables, the binary variable *non-farm-act*, the variable *occ* with 7 occupational categories and an 8<sup>th</sup> category of students, pensionists and unemployed, and the variable *ind*, indicating in which industry the occupational choice is realized. Assets, household incomes, education, family size, access to credit markets, are factors earlier authors established as enablers of non-farm business enterprises in various studies across the developing world. We estimate the binary choice to take on a non-farm business as a logit model, then the specification of particular choice and the economic activity as multinomial logit models, estimating how the set of explanatory variables – with energy access as one of them – affect the probability of becoming active in a certain business field.

From the binary choice model (case 1), we find for rural non-farm activities that education level increases the probability of entering a non-farm business activity, decreases with age, decreases when the individual only has access to informal loans from family or friends and is higher with energy access. The latter however, is only barely significant at the 90% level. Turning to the multinomial logistic regression of *occ*, the occupation “Self-employed in agriculture and livestock” is used as the baseoutcome. Explaining variables are the same as in case 1, with energy access being significant at the 99% level and positive for selecting Self-Employed Non Farm Business enterprise, and Self-Employed Non-farm Independent contractor, technician, professional etc. as an occupation over Self-employed in agriculture and livestock.

Looking at the choice of economic activity, access positively and significantly affects the probability to go into handicrafts, shops, or mobile phone services. For instance, the probability for entering manufacturing, decreases with age, increases with energy access is not significantly influenced by the formal aspects of loans. The full paper will contain the estimation results and the respective goodness of fit measures.

Lastly, we estimate the effect of energy access, occupational choice and industry on the natural logarithm of incomes. Incomes increase with access, are higher in non-farm enterprises compared to subsistence farming (the variable *occ* is coded as 1 for Salaried Employee, Non-Farm, 5 for Self-Employed Agriculture and 10 for unemployed, retired, student and other occupations) and are not significantly increasing with industry.

## Conclusions

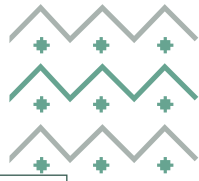
Household survey data for Nigeria were analyzed to elicit the effect of energy access on the choice of economic activities in rural areas. The cross-sectional regressions show that the probability of taking on a non-farm activity is higher in areas with energy access. However, additional factors seem to play a role, such as education, age, asset ownership and access to formal loans. The analysis will be extended to three more African countries (Niger, Zambia and Kenya) to study similarities and differences and to infer enabling factors to fully exploit the possibilities of productive use of energy for more and better jobs.

## References

- Bhatia, Mikul, and Niki Angelou. 2015. *Beyond Connections: Energy Access Redefined*. World Bank. <https://doi.org/10.1596/24368>.
- ESMAP. 2018. “Nigeria - Multi-Tier Framework for Measuring Energy Access Household Survey.” World Bank. [file:///C:/Users/WB589753/Downloads/mtf\\_nigeria\\_062820\\_web%20\(1\).pdf](file:///C:/Users/WB589753/Downloads/mtf_nigeria_062820_web%20(1).pdf).
- Khurana, Tanvi, and Seema Sangita. 2022. “Household Access to Electricity and Non-Farm Business in Rural India: A Panel Data Analysis | Elsevier Enhanced Reader.” 2022. <https://doi.org/10.1016/j.esd.2022.01.008>.
- Nagler, Paula, and Wim Naude. 2016. “Non-Farm Enterprises in Rural Africa: New Empirical Evidence,” 52. SDG7 Custodians. 2022. “Tracking SDG7: The Energy Progress Report 2022.” May 2022. [https://cdn.who.int/media/docs/default-source/air-pollution-documents/air-quality-and-health/sdg7-report2022-052622-final\\_web.pdf?sfvrsn=e93a8386\\_4&download=true](https://cdn.who.int/media/docs/default-source/air-pollution-documents/air-quality-and-health/sdg7-report2022-052622-final_web.pdf?sfvrsn=e93a8386_4&download=true).







## AN ANALYSIS OF POWER OUTAGES INDUCED ELECTRICITY BACKUP CHOICE IN PAKISTAN

Faisal Jamil (Corresponding Author)

School of Social Sciences & Humanities (S3H)

National University of Sciences & Technology (NUST),

Islamabad, Pakistan

Tanweer ul Islam

S3H, NUST, Islamabad, Pakistan

Energy Access

### Abstract

Regular electricity supply is essential for economic growth and wellbeing in a modern economy. In general, supply from electricity grid is the main source of power wherein the grid comprises of interconnected transmission and distribution networks for connecting electricity consumers to power plants. Supply must match the demand in the real-time for a reliable and regular electricity supply and in case of any discrepancy; system is managed by power cuts for certain set of consumers. Power cuts or supply disruptions are generally termed as power outages or load shedding and is quite common in Pakistan. The country has a long history of overlapped energy crises especially since 1980s that are stated as an outcome of inadequate planning and short-term policy choices.

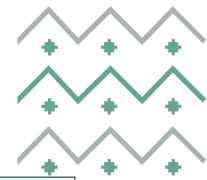
Outages are costly for consumers and firms and the cost generally increases with frequency and duration of power supply interruption. Economic theory suggests that consumers will go for alternate energy devices if cost of unmet electricity demand due to outages exceeds the cost of available backup energy source. Past crises weaken the perception of electricity consumers about the public utility's capacity to timely and adequately plan and manage power supply. As a result, people choose among alternative back up options including uninterrupted power supply (UPS), natural gas or gasoline based electric generators and solar systems. This study finds the determinants of this choice based on the consumers perception regarding the power supply system. It uses a primary data collected from 952 respondents in the twin cities of Islamabad and Rawalpindi, Pakistan. This study employs multinomial logistic regression to cater for the multicategory nature of our dependent variable i.e., backup choices. Multinomial logistic regression utilizes maximum likelihood estimation to compute the probability of categorical membership.

The results show that house ownership has a positive and significant impact on the choice of electricity backup as it favors all the options as compared to the base category of no backup. Interestingly, the electricity theft and consumer satisfaction variables are detrimental to opting the solar technology. The UPS and small generator are more likely the choice if consumption is within the range of 300-

700 units per month however, chances of solar system adoption increases if it exceeds 700 units per month. Education of the respondent is positively and significantly affecting the backup choice and for solar technology adoption, it is true only for university graduates. The findings have important policy implications. The transition towards the solar energy is mainly driven by the household strategy for maintaining energy backup therefore, it is pertinent to provide microfinance facilities. Moreover, the energy sector reforms need to be improved for efficient electricity supply system that help avoiding inefficient backup options.

Results Table: Relative Risk Ratios for Backup Choices

<b>Base: No Backup</b>	<b>RRR-UPS</b>	<b>RRR-Generator</b>	<b>RRR-Solar panel</b>
<b>Residential Status (Base: Rented House)</b>			
Govt. Residence	2.74***	2.28	8.66***
Own House	1.52***	2.80***	2.53***
<b>Region (Base: Islamabad Rural)</b>			
ISB Urban	1.49*	2.68**	1.70
RWP Urban	1.75***	3.42***	1.51
RWP Rural	0.16***	0.001	0.64
<b>Employment Status (Base: Unemployed)</b>			
Self-employed	1.63	1.08	0.54
Govt. Employed	2.04**	0.56	1.58
Informal Sector	1.22	0.40*	1.20
Pvt. Employ	1.25	0.74	1.10
<b>Electricity Consumption (Base: Units&lt;300)</b>			
Units(300-700)	2.87***	6.81***	1.44
Units(>700)	2.81	17.17**	11.01*
<b>Education (Base: Education&lt;10)</b>			
Edu(11-16)	1.99***	2.18**	1.24
Edu(>16)	5.33***	4.33***	4.11***
<b>Gender (Base: Female)</b>			
Male	0.58***	0.99	1.18
Monitoring	0.82	0.57**	1.03
Theft	0.87	0.68**	0.55***
Consumer Satisfaction	0.94	0.87	0.48***
Family Size	1.02	1.03	1.10**
Income	1.00**	1.00	1.00
Intercept	0.80	0.59	1.13
Observations=952	LR Chi2(57)=3017.32	Prob>Chi2=0.0000	Pseudo R <sup>2</sup> =0.1451



## ***The Economic Impact of Energy Poverty and Sustainable Development Goals (SDGs)***

Moodhi Alotaibi, Arab Open University (AOU), Riyadh, KSA, +966551422202, [moodhi.alotaibi@arabou.edu.sa](mailto:moodhi.alotaibi@arabou.edu.sa)

Omaimh Ali, Arab Open University (AOU), Riyadh, KSA, +966552150166, [Dr.omaima33@yahoo.com](mailto:Dr.omaima33@yahoo.com)

### **Overview**

There has been a growing interest in global energy issues and the international policies needed to conserve energy, which is important for global economic growth and achieving sustainable development goals. Countries with different economic components seek to focus on specific sectors in order to direct the course of development in a way that is in line with current changes at the local and global levels. More than 40 percent of the world's population depends on biomass energy, which uses local resources and preserves traditional and primitive forms of energy, according to the OPEC Organization for International Development (OFID). Thus, energy poverty constitutes a fundamental challenge for transforming developing countries into developed ones.

There is a debate about the possibility that this poverty will have a significant negative impact on the development path, as energy poverty is an integral part of the overall factors of underdevelopment that surround underdeveloped societies. Therefore, it is important to investigate the impact of energy poverty on economic growth and the Sustainable Development Goals (SDGs) to provide advice and recommendations to developing countries on what to do in the future to balance economic growth and reduce energy poverty.

This paper investigates the impact of energy poverty on economic growth and the Sustainable Development Goals (SDGs) in developing countries. These countries witnessed various changes in the economy, consumption and production. The main study question is; How can people get out of energy poverty in line with the seventh goal of the Sustainable Development Goals (SDG)? Then followed by several questions: 1- What is energy and what is meant by energy poverty? 2- What is sustainable development, and what are its goals? 3- How important is energy for climate and sustainable development? 4- How can the seventh goal of the sustainable development goals be achieved? To achieve the study objectives, the study assumes that: 1- there is a strong and direct relationship between energy and poverty. 2- Renewable energy is essential in achieving indicators of sustainable development.

### **Methods**

The methodology and this part consists of four procedures to obtain results showing the impact of energy poverty on economic growth and the Sustainable Development Goals (SDGs) in developing countries.

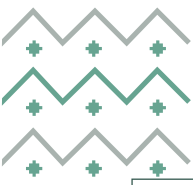
First: A questionnaire was designed to study energy poverty and the Sustainable Development Goals (SDGs) in developing countries. Second: The study chose a random sample from inside and outside the Kingdom, by distributing the questionnaire electronically. The responses reached (256) and they are distributed according to the variables of gender, academic degree, and type of job. Third, to verify the validity of the study tool represented in a questionnaire, the stability was calculated using the internal consistency method using the Cronbach's Alpha equation on the responses of the total study sample when analyzing the results. The following table shows the reliability analysis of the study scale, showing the values of the Cronbach's alpha coefficient for the study concepts.

Table 1: Cronbach's Alpha Analysis

Reliability Statistics	
Cronbach's Alpha	N of Items
.915	17

Source: Authors calculations

Fourth, the statistical analysis of the degree of agreement using the statistical package for social sciences (SPSS). In order to interpret the results and find out how people can be lifted out of energy poverty, in line with the seventh goal of the Sustainable Development Goals. The following evaluation criteria were adopted: from 1 to 1.80 strongly disagree, from 1.81 to 2.60 disagree, from 2.61 to 3.40 neutral, from 3.41 to 4.20 agree, from 4.21 to 5.00 fully agree



**Results**

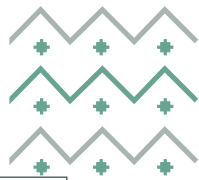
In order to answer the research questions, this paper presents the descriptive statistics for each variable. Table 2 presents the calculated value, the arithmetic mean, standard deviations, and the significance of the calculated value.

**Table 2: Descriptive Statistics**

	N	Mean	Std. Deviation	Indication	calculated value
<b>The first question: Is there a strong and direct relationship between energy and poverty?</b>					
.Access to energy is critical to reducing poverty	256	4.4688	.61277	Fully agre	7
Energy poverty negatively affects economic development in the short term	256	4.4531	.79072	Fully agre	9
Decreased energy costs are a major part of the global energy landscape	256	4.5156	.73013	Fully agre	4
Many countries still subsidize fossil fuels as a way to reduce costs to consumers	256	4.0938	.80623	Agre	16
Energy conservation efforts, mostly benefiting the wealthy who consume, and undermining, the poor	256	4.4063	.74558	Fully agre	11
Recently, international public financial flows to developing countries to support clean energy have been declining	256	4.0625	.88340	Fully agre	17
There must be a global effort to understand the needs of the very poor and vulnerable countries and how to address them	256	4.5625	.82842	Fully agre	3
Although the private sector finances most investments in renewable energy, public financing remains key to attracting private capital	256	4.4062	.82545	Fully agre	12
Billions in low- and middle-income countries still do not have access to clean fuels	256	4.4531	.77063	Fully agre	10
<b>The second question: Is renewable energy necessary in achieving sustainable development indicators?</b>					
Renewable energy is playing an increasingly important role in helping countries develop modern and secure energy systems	256	4.6406	.64758	Fully agre	1
Disruptive technologies such as smart grids, smart meters, and geospatial data systems have improved energy planning	256	4.5000	.66273	Fully agre	5
Clean energy protects organisms of all kinds, especially endangered organisms	256	4.3906	.84235	Fully agre	13
The use of clean energy limits the formation and accumulation of solid, liquid and gaseous wastes	256	4.4844	.81153	Fully agre	8
The level of financing remains below what is required to achieve SDG 7, especially in the least developed countries	256	4.5000	.73030	Fully agre	6
International public flows to countries that lack financial resources to support energy transitions constitute a large part of international cooperation	256	4.2969	.78575	Fully agre	15
.Energy is central to the development process	256	4.6250	.62622	Fully agre	2
Low-cost electricity generated from renewable sources can provide large proportions of the world's total electricity supply	256	4.3906	.80425	Fully agre	14
Valid N (listwise)	256				

Source: Authors calculations





From the previous table, the following can be concluded:

1- The estimates of the study sample are in the field of the strong and direct relationship between energy and poverty. She strongly agreed with all items of the question except for the paragraph (many countries still subsidize fossil fuels as a way to reduce costs for consumers). She agreed. The arithmetic mean ranged between (4.56-4.06).

2- The sample's estimates in the field of renewable energy being necessary in achieving sustainable development indicators were strongly agreed on all items, where the arithmetic mean ranged between (4.64 -4.29).

The analysis of the basic data of the study hypotheses: A one-sample test was used to analyze the study data and answer its questions.

### Discussion Results

The finding shows that the level of statistical significance is equal to (0.000), which confirms that the factors mentioned for the first and second questions are statistically significant.

Overall, the results showed that there is a strong and direct relationship between energy and poverty, according to the results of the study sample. Which means that the higher the energy, the lower the poverty rate. She also explained that renewable energy is essential in achieving indicators of sustainable development, despite the high costs of its production compared to fossil energy and the difficulty of expanding its use, as its positive role in combating environmental pollution and diversifying sources of energy consumption.

### Conclusions

This paper tested the impact of energy poverty on economic growth and the Sustainable Development Goals (SDGs) in developing countries. Based on the findings of the study, it recommends the following:

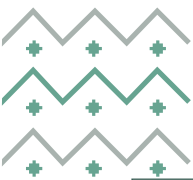
- Renewable energy resources that are common to all should be invested, with the aim of achieving a green economy, through energy conservation
- Necessarily protecting renewable energy from waste and protecting fossil energy from depletion.
- Protecting the environment from pollution, especially in the oil-producing countries, and preserving the financial resources to combat the environment from pollution.
- Environmental culture should be given great importance in the educational and cognitive aspects.
- Seeking the concept of creativity that puts scientific skills and expertise in the development of the renewable energy industry, with the aim of transforming scientific and laboratory knowledge into a tangible reality that can be invested in an optimal way.
- There should be a global effort to understand the needs of the very poor and vulnerable countries and how to address them.
- Developed economies should play an active role in Africa and avoid a slow energy transition that causes Africa to lag behind global markets and miss emissions reduction targets.

### References

- 1- Douglas Muschet (2020). Translated by Wafaa Shaheen, "Principles of Sustainable Development", (International House for Cultural Investments), first edition, Egypt.
- 2- Muhammad Salih Al-Ajili, Muhammad (1433-2012), A Dictionary of Geographical Terms and Concepts, Dar Al-Safaa for Publishing and Distribution - Amman.
- 3- Fouad Al-Jumaili and M. Abdullah Odaibat (2019), Introduction to Building Construction.
- 4- Nawar Sabih (2021). "Africa Suffers.. Should It Address Energy Poverty First, Or Respond to Pressures of Carbon Neutrality? Article" Energy Newspaper - Reports of the Energy Research Unit.
- 5- Teresa Smith (2022). "Energy Transition: The Fossil Fuel Problem," Energy Journal.
- 6- Zaazou, Zainab Abbas, (2020).The Role of Renewable Energy in Achieving Sustainable Development and The Obstacles It Faces: A Field Study Applied to The Ministries of Electricity and Petroleum in Egypt 2030, (MSA), Egypt.
- 7- Majed S. Almozaini (2019). "The Causality Relationship between Economic Growth and Energy Consumption in the World's Top Energy Consumers", International Journal of Energy Economics and Policy | Vol 9 • Issue 4
- 8-Shafqut Ullah 1, Muhammad Khan 2 and Seong-Min Yoon 3, (2021):" Measuring Energy Poverty and Its Impact on Economic Growth in Pakistan" Sustainability 2021, 13, 10969. <https://doi.org/10.3390/su131910969>
- 9- Jayasinghe, M., Selvanathan, E. A., & Selvanathan, S. (2021). Energy poverty in Sri Lanka. Energy Economics, 101, 1-12. [105450]. <https://doi.org/10.1016/j.eneco.2021.105450>
- 10- United Nations – Sustainable Development knowledge platform "Transforming our world: the 2030 Agenda for Sustainable.
- 11- Esther Duflo, Michael Greenstone and Rema Hanna, Gaëll Mainguy (2008), Indoor air pollution, health and economic well-being, OpenEdition Journals, 1.12008 | Vol.1 / n1Surveys.
- 12- International Renewable Energy Agency -IRENA (2018), *Renewable Energy Outlook: Egypt*, International Renewable Energy Agency, Abu Dhabi.







## ***SOLAR ENERGY ACCESS IN RURAL OFF-GRIDD AREAS OF BANGLADESH: DETERMINANTS AND IMPACTS***

Sakib Bin Amin, North South University, +8801758871668, sakib.amin@northsouth.edu  
Mainul Islam Chowdhury, North South University, +8801710161871, mainul.chowdhury@northsouth.edu  
S.M. Asif Ehsan, North South University, +8801796398919, syed.ehsan@northsouth.edu  
S.M. Zahid Iqbal, North South University, +8801799114433, zahid.iqbal@northsouth.edu

### **Overview**

In this paper we aim to identify the important socio-economic, geographic, and demographic factors at the individual, household, and community level, that affect the access and adoption of solar home system (SHS) in rural Bangladesh. Our study has two major parts of analysis. In the first part, we identify different factors that determine the SHS adoption of households. For this part of the research, households' several individual-level and socio-economic factors' information such as their income, education, age, access to other sources of electricity, access to credit, number of household members, neighbors' access to SHS, way of obtaining SHS, reasons for not getting SHS, and information on many other important factors were collected through a questionnaire survey. For the second part of our study, we explore various economic and social impacts of SHS adoption on households in rural Bangladesh. Among others, some important socio-economic aspects in this part of our analysis include education and health, economic opportunities, and the living standard of impoverished rural households.

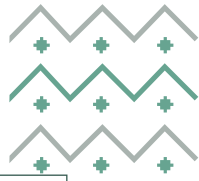
### **Methods**

To attain the research objectives, in this paper, we have incorporated both quantitative and qualitative techniques. For the quantitative part, utilizing a primary questionnaire-survey dataset, we have applied the random utility model for discrete choice decision-making, based on the Probit Binary Response regression method. Besides the empirical analysis, the qualitative part of the paper helped us obtain an in-depth picture of SHS's current scenario in rural areas by finding out the nature and causes of SHS adoption, socio-economic impacts of SHS, and SHS's future development in Bangladesh.

Our questionnaire survey for this study included 500 households (one respondent from each household). To see if the SHS barriers vary across different geographical regions of Bangladesh, our study areas include coastal off-grid villages, *char* (small island) and *haor* (wetland) areas, and impoverished northwestern regions of the country. The survey area includes villages where the SHS program has been implemented by POs and comparable non-project regions that do not have access to SHS. The respondents were randomly selected from both with-SHS and without-SHS groups of households, upon consultation with the *Union Parishad* (local government) offices. The households with and without SHS might have unobserved attributes that can contribute to their being in the specific group, which can give rise to classic endogeneity issues and might lead to biased estimation results. However, our study's random selection of households ensures that the unobservable factors or characteristics of households with and without-SHS are not correlated with the covariates included in our estimation process. In other words, the random selection followed in this paper makes the two groups of households (with and without SHS) as comparable as possible, which can significantly reduce the selection bias. Our primary survey respondents are divided along the line of gender, income groups, and ethnicity in the selected regions.

The qualitative part of this paper utilizes a number of qualitative data collection tools such as key informant interviews (KIIs), Focus Group Discussions (FGDs), and case studies conducted alongside the primary questionnaire survey to gather further insights into the factors influencing SHS adoption decisions and impacts of SHS in rural Bangladesh. A total of four Key Informant Interviews (KIIs) and four Focus Group Discussions (FGDs) have been conducted as part of the study. In addition, eight real-life case-studies have been collected to better understand the barriers and motivations as well as the impacts of SHS on households and communities. The KIIs were carried out among households from different socio-economic strata, providers of SHS, officials from NGOs who are involved in the distribution and maintenance of SHS, and other stakeholders. Each FGD ensured the participation of 20 to 25 individuals, with a considerable number of women in each group. Besides, an enabling environment was created to ensure marginalized and impoverished citizens' participation in the FGDs. By combining qualitative and quantitative methods, we obtained an in-depth picture of SHS's current scenario in rural Bangladesh. These also helped us highlight the existing barriers to SHS adoption and SHS's future development in Bangladesh. Moreover, the eight case studies collected from the field have helped us further understand the experiences of SHS users in installing SHS, effects on their households, and reasons for not obtaining SHS for the non-users.





## Results

Our results suggest that the households from the *char*-areas and coastal areas are more likely (by 29 percent and 10 percent respectively) to obtain SHS compared to other areas. Also, access to SHS credit increases the adoption likelihood by 35.5 percent, and it is statistically significant. Other factors significantly affecting the household's decision to adopt SHS in Bangladesh include household habitat, household size, primary occupation, education level, and asset value. Finding that financial constraint is one of the most important factors hindering the household level SHS adoption, we also investigate determinants and barriers of obtaining credit-access for purchasing and installing SHS. Access to SHS-credit was found to depend on the household's primary occupation, NGO activity, and income groups. Households informed about the SHS by NGOs are, on average, 40.3 percent more likely to get credit-access for purchasing SHS than households informed by their neighbors or relatives. Being from *char* and coastal areas increases the likelihood of receiving SHS credit by 18.4 percent and 19.7 percent, respectively. Additionally, if the household head's primary occupation is agriculture, the household is 26 percent more likely to receive the SHS credit compared to other households. However, years of schooling, and being from low-income groups negatively affect the possibility of obtaining SHS-credit. Interestingly, we find that the total asset and land ownership value do not play any important and statistically significant role in getting SHS loans.

## Conclusions

This study finds households' habitat location (from *char* or coastal area), their primary occupation (agriculture or non-agriculture), having livestock asset, total asset ownership, household size, having school-going children in the household, and the type of habitat (*kacha* or *paka*) play statistically significant and positive roles in the SHS-adoption decision of households. On the other hand, total land ownership and way of being informed about the SHS (from NGO vs from neighbors-relatives), are significantly and negatively related to household SHS adoption decision. Having access to credit is a significant determinant of adopting SHS because of the high upfront cost of the SHS installation. Hence, we explore factors that can improve or deter households from obtaining loans for purchasing SHS.

The majority of the households, both from the with-SHS and without-SHS groups, agree that access to SHS has improved or would improve their standard of living. Most households surveyed in our study agree that having SHS at home improves the education and health facilities. The majority of the households in our study also do believe that access to SHS has improved local infrastructure and has created more business opportunities.





## ***ASYMMETRIC EFFECTS OF ENERGY DEPENDENCE ON INTERSTATE RELATIONS***

[Soytas, Mehmet, KFUPM, Phone, msoytas@gmail.com]

[Hatipoglu, Emre, KAPSARC, +966112903162, emre.hatipoglu@kapsarc.org]

### **Overview**

Empirical studies looking at energy interdependence and conflict treat the marginal effect of a unit increase in interdependence on the probability of conflict onset the same as a unit decrease on the probability of conflict onset. However, anecdotal evidence suggests that the effect of changes in the level of interdependence may be asymmetric. Diversification of resources, the influx of alternative renewable energy and/or exploration of an own resources may allow an importing state to sustain cordial relations with its supplier even when the level energy trade subsides between them. The secondary institutional ties formed during increased levels of trade between the two countries further underpins sustained peaceful relations within the dyad during periods of declined trade. Accordingly, we expect that a country's increasing dependence on an exporter will decrease the likelihood of militarized interstate dispute (MID) initiation between the two countries, but a decrease in such dependence will not necessarily have an increasing effect on the likelihood of MID initiation. Our nonlinear autoregressive distributed lag (NARDL) model developed by Shin et al. (2014) confirm our expectations.

### **Methods**

We test our hypotheses in the context of how United States interacts with its energy suppliers in the realm of foreign policy. Towards this end, we employ the nonlinear autoregressive distributed lag (NARDL) model developed by Shin et al. (2014) to investigate the cointegrating relationships and asymmetric interactions between the variables. This model is an extension of the linear ARDL model (Pesaran et al., 2001; Pesaran and Shin, 1998). The performance of the ARDL models is very strong for small sample size works (Pesaran and Shin, 1998; Pesaran et al., 2001; Shin et al., 2014). The NARDL model does not require that the variables have the same integration order. Unlike other counterpart models (e.g. vector error correction model (VECM)), the integration orders of the variables could be a mixture of I (0) and I (1). The use of this novel method enables us to distinguish between short- and long-term effects of various measures of energy dependence on the likelihood of a militarized interstate dispute onset and on the level of foreign policy preference similarity between the U.S. and its energy suppliers.

### **Results**

Our results indeed indicate that energy trade's effect on interstate relations is not symmetric. More specifically, increasing levels of energy trade with the U.S. makes suppliers more cordial with the U.S. However, decreasing levels of energy trade between the U.S. and its suppliers does not lead to more conflictual relations. Robustness checks with alternative measures of foreign policy preference similarity confirms our results.

### **Conclusions**

A more solid understanding of the causes of this asymmetry will improve our understanding on how energy trade shapes interstate relations beyond immediate economic means. One possibility could be that energy trade constitutes a springboard for further institutional cooperation between the U.S. and its suppliers. That such trade leads to further business ties, hence political interests to keep relations cordial in the longer term is another possibility. Our findings also have implications for international relations literature more generally. More specifically, these findings call for revisiting the conceptual links on how interdependence shapes states see each other. Policy-wise, we should also note that even short-term improvements in energy trade may lay the foundation for longer-term peaceful relations.

### **References**

Shin, Y., Yu, B., Greenwood-Nimmo, M., 2014. Modelling asymmetric cointegration and dynamic multipliers in a nonlinear ARDL framework. Festschrift in honor of Peter Schmidt. Springer, New York, NY, pp. 281–314.





## Submission Summary

**Conference Name**

44th IAEE International Conference - 2023

**Paper ID**

62

**Paper Title**

The Security of Energy Demand

**Abstract**

Energy security debates and research focuses almost exclusively on the question of the vulnerability of energy supply to political disruptions which can result in price spikes and macroeconomic damages, especially in the oil market. However, a related question centers of the vulnerability of, and uncertainty over, energy demand. The global impact tends to be much less, but the damage is concentrated in energy exporting nations and usually a subset of them. This paper will focus on the security of oil demand in particular.

In the short-term, uncertainty about oil demand creates volatility in prices and difficulties for market stabilizing organizations like OPEC. The threats range, in ascending order of seriousness, from weather fluctuations to recessions to pandemics. Politics can affect oil demand in the short term, but typically on a minor scale, such as when importing nations change their tariffs causing buyers to hoard before they take effect. Longer term, uncertainty about net demand for OPEC means uncertainty for upstream investment, as witness the many times importing nations have urged exporters to add capacity, only to see that capacity idle.

This paper will quantify the past and possible future vulnerability to demand uncertainty and fluctuations, the economic impact and possible policy responses.

**Created on**

9/2/2022, 5:05:48 PM

**Last Modified**

9/2/2022, 5:05:48 PM

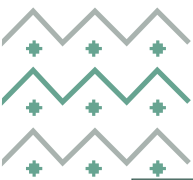
**Authors**

Michael Lynch ( EPRINC ) < [lynch@energyseer.com](mailto:lynch@energyseer.com) >

**Primary Subject Area**

Energy Security and Geopolitics





## ***THE EASTERN MEDITERRANEAN ENERGY GEOPOLITICS: A "CYPRUS CENTRIC" ANALYSIS OF THE CURRENT AND FUTURE CHALLENGES***

Dr. Savvas Pappasavvas, Consultant/Strategy International, 00357-97786156, spapasavvas@strategyinternational.org

### **Overview**

Following the Republic of Cyprus (RoC) decision in 2013 to proceed with exploitation activities within its Exclusive Economic Zone (EEZ) and consequently its determination to be transformed from an almost exclusively energy consumer to a producer and an energy hub has caused the development of new agreements and synergies based on mutual interests. At the same time, though, it has driven the development of a new field of confrontation with the Turkey/Turkish Republic of Northern Cyprus (TRNC) axis as the conflict between the sides would not be limited to the so-called "Cyprus Problem".

The non-synergy between the two sides has already caused delays to the particular energy program, has increased the risk of enterprises investing in this project and, in general, has discouraged possible stakeholders to invest in this program. However, in the post-Ukraine war era, both the existing and the potential additional natural gas reserves in the RoC EEZ have an increased value towards the EU's intention to become, at least partially, independent from the Russian energy reserves.

Thus, this project aims:

- (a) Under a "Cyprus-centric" framework, to make an overview of the main facts related to the Eastern Mediterranean energy security with the emphasis given in the period from 2016 and onwards.
- (b) To present the possible energy security challenges and opportunities in the upcoming years.

### **Methods**

As the RoC energy geopolitics is a relatively new area of study, it is still underdeveloped, and consequently and the existing peer-reviewed literature is still relatively limited. In contrast to the academic/secondary sources, there is a respected number of primary sources, including public statements and official documents, focusing on the RoC energy geopolitics. This lack of secondary and the relative abundance of primary sources has led us to apply a method of analysis focusing on discourse and, more specifically, on the statements made by the people impacting the RoC foreign and energy policy. In particular, we have decided to use a method referred to the literature as Political Discourse Analysis (PDA). According to Christina Schaffner (1996), PDA is a sub-category of general discourse analysis used for analyzing political statements. Also, Henrik Larsen (1997:23) has argued that "political discourse analysis can provide explanations regarding the way actors act and may provide an analysis deeper than the analysis of materialist structures."

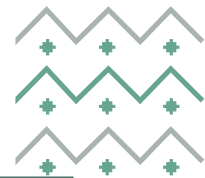
At the same time, some scholars question its credibility and applicability. Among others, Isabella and Norman Fairclough (2012) have highlighted the lack of a clear distinction between political and other types of discourse analysis. Even though they share the same opinion with Larsen (1997) that a common view on political science can help, at the same time, they have argued that it is not an easy matter due to the complexity of the issues related to the state's interests. At the same time, we share the same view with George Berridge (2015), claiming that not all the issues discussed between decision-makers get in public.

The weaknesses mentioned above have left us with a dilemma; either trying to conceal the shortcomings of PDA or applying a second method simultaneously. This paper has used a second method and tries to verify or reject the findings originating from PDA. This second method is usually presented in the literature as "semi-structured elite interviewing" (Galleta, 2013). By definition, this is a method of interviewing based on the information collected and analyzed by leading experts on significant themes. Rathbun (2008) has characterized it as a unique method because it has allowed the researchers to ask elite people the questions to which they wanted answers. He has even described it as the most direct and targeted method in qualitative-based methodology.

Regarding the data analysis, we have used NVIVO software. According to Kristin Bazeley and Patricia Jackson (2019), the particular software can contribute to the completion of a project by managing data and ideas and organizing conceptual and theoretical knowledge generated from the project. Moreover, through NVIVO, we were able to query data, ask in simple terms complex questions stemming from the data, provide straightforward answers, and report and visualize them even through charts.







## Results

This paper has ended up to the following results:

(a) There are three groups of parameters all the stakeholders (states, organizations, enterprises) consider when discussing energy-related issues: the geopolitical, the economic and technological/environmental. However, the fact that each stakeholder hierarchies those parameters differently makes cooperation tricky.

(b) In the aftermath of the war in Ukraine, the RoC natural gas reserves can contribute to the transition of the EU to "green energy", as presented in the 2050 energy agenda.

(c) There are four possible ways to transfer the RoC and the Eastern Mediterranean energy reserves in general to the EU market: (a) a liquefaction facility in Cyprus, (b) a pipeline via Turkey, (c) through the "East Med" pipeline, (d) through the existing Egyptian gas pipeline. As presented in the paper, each of these alternatives has its pros and cons.

(d) The RoC must decide whether it wants to be primarily an energy producer or an energy hub with all the (geo)political and economic advantages and disadvantages of every decision.

(e) The intention of the RoC to harmonize its energy interests with those of the key regional players (Christodoulides, 2018) is not as easy as it looks on the first sign. The involvement of regional players with different interests makes their support for the particular program limited to specific actions that are different for each player. However, over the last decade, we have seen steps forward from the RoC by abandoning a monothematic policy within the EU organs and developing new bilateral agreements (Kasoulides, 2019). However, in particular cases, at least based on public statements, the RoC did not get the support expected for its energy program.

## Conclusions

The post war in Ukraine world, at least for the EU and its neighboring sub regions will be massively differentiated, at least in the area of energy geopolitics. This new developed environment apart from new challenges will also develop new opportunities. Regarding the Eastern Mediterranean energy geopolitics can be characterized as dynamic, fluid and inevitably regularly differentiated. Therefore, their analysis requires taking into consideration various parameters which are often multidisciplinary.

As part of this difficult equation the RoC energy program can contribute on fulfilling the EU energy agenda towards its independency from the Russia reserves. However, the opposition by the Turkey/TRNC axis requires a more active involvement both from the EU and also from the regional players. We must bear in mind that:

- The RoC has not signed the final agreements with the oil/gas enterprises in all the sea blocks.
- The East – Med pipeline is considered possible but is still on paper.
- Turkey upgrades its, independent, exploitation capabilities.
- There is not a clear view regarding the total amount of natural gas existing within the RoC subsoil.

Summarizing the above we believe the exploitation of hydrocarbons in the RoC EEZ enters a new period in the post Ukraine war era. The successful handling of the new threats and the taking advantage of the new opportunities will determine whether the RoC energy program will end up being a regional blessing or a curse.

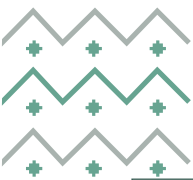
## References

### Books

- Bazeley K & Jackson P (2019). *Qualitative Data Analysis with NVIVO*. London: SAGE Publications
- Berridge, G. (2015). *Diplomacy: Theory and Practice*. London: Springer.
- Galleta, A (2013). *Mastering the Semi-Structured Interview and Beyond*. New York and London: New York University Press
- Fairclough, I., & Fairclough, N. (2012). *Political Discourse Analysis: A Method for Advanced Students*. London: Routledge.
- Kasoulidis, I. (2019). *30 Years Present. Ideas and Thoughts for our Cyprus (in Greek)*. Nicosia: Kathimerini
- Larsen, H. (1997). *Foreign Policy and Discourse Analysis: France, Britain and Europe*. Oxfordshire: Taylor & Francis.

### Public Statements

Christodoulides, N. (2018, November 16). *The Republic of Cyprus National Security Strategy*. Retrieved from <https://www.youtube.com/watch?v=IwJwZxBvRP0&t=611s>



## SHORT-TERM ACTIONS TO ADDRESS THE CURRENT OIL AND GAS CRISIS IN THE APEC REGION

Christopher Doleman, Asia Pacific Energy Research Centre, +81-3-5144-8556, christopher.doleman@aperc.or.jp

### Overview

Even before the Russian-Ukrainian conflict began in early 2022, the world was drifting towards a potential energy crisis. Balances of both oil and gas were tightening, as shifting investor preferences, an uncertain and uneven pandemic recovery, supply-chain bottlenecks, and other factors limited the responsiveness of oil and gas supply to price signals as demand crept back to pre-pandemic levels. The conflict exacerbated this tightness. Much of the world is racing to reimagine their global energy supply chains to align with shifting geopolitical realities. Because incremental supply will not arrive overnight, prices are rising to unprecedented levels, challenging both oil and gas security on the grounds of not only affordability but availability.

The world is currently enduring a multi-layered, protracted energy crisis that will have serious ramifications for the 21 economies that comprise the Asia Pacific Economic Cooperation (APEC) forum. APEC member economies account for 60% of oil demand, over half of global gas demand and almost two-thirds of LNG imports. The reality of higher oil and gas prices and the potential for acute shortages over the next several years could inflict devastating hardship on the APEC economies and derail their recovery from the pandemic.

According to the Carbon Neutrality scenario of the 8th APEC Energy Demand and Supply Outlook, the APEC region will continue to rely on oil and gas throughout this decade even if it embarks on a path to carbon neutrality. While lower oil and gas supply requirements will reduce the impact of oil and gas supply disruptions throughout the 2020s, reliance on oil and gas will continue to make them susceptible to oil and gas disruptions.

However, APEC members still possess the ability to soften the impact of the crisis. In addition to vast oil and gas resources, some APEC members are adept at initiating and sustaining demand response measures during energy shortages, and others have illustrated a history of cooperating to reduce the impact of previous supply disruptions through measures like collective oil stockpile releases and LNG re-exports.

This paper identifies several actions that APEC members could take to reduce the cost of supply disruptions and improve oil and gas security in the short term. These actions are centered around reducing supply requirements, increasing the own-price elasticity of both supply and demand, and mitigating the impact of supply disruptions with storage. Some of the recommendations are prescriptive, while other are descriptive case studies based on the actions that member economies have already taken.

### Methods

The framework for analysis is based on the principal that the cost of an oil and gas supply disruption to an economy (cost of disruption  $f$ ) can be conceptualized as a function of that fuel's share of total primary energy supply ( $S_f$ ), the fuel's own-use price elasticity of demand ( $\epsilon_d$ ), the fuel's own-use price elasticity of supply ( $\epsilon_s$ ), the import dependence of the fuel ( $I_f$ ), and the amount of stockpiles of the fuel ( $R_f$ ):

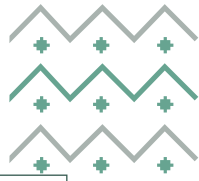
$$\text{cost of disruption}_f = f(S_f, \epsilon_d, \epsilon_s, I_f, R_f)$$

This is a general, theoretical framework, and not meant to measure the exact cost of disruption, but rather as a framework to identify routes to reducing the cost of the current energy crisis on APEC member economies.

The paper will mostly focus on actions that either increase the elasticity of demand and supply or increase the use of oil and gas stockpiles. While this paper largely ignores the role of reducing import dependence through energy efficiency improvements, increasing the elasticity of demand will serve the goal of reducing oil and gas demand, and in turn import dependence.

### Results

Several actions to reduce the cost of oil and gas supply disruptions are studied, including, but not limited to:



- Japan's use of conservation campaigns has successfully averted blackouts during periods of tight power supply following both the 2011 Tōhoku earthquake and two electricity shortages in 2022. Japan is hoping to mimic the success itself by rolling out a natural gas conservation campaign during the upcoming winter. Furthermore, this success can provide a useful framework for other APEC members to mimic to increase the elasticity of natural gas demand via lower city gas and electricity usage.
- Several APEC LNG importers are embracing a gas-to-coal switch to reduce their exposure to high natural gas prices. Furthermore, Korea and Japan are working to integrate more nuclear energy into their fuel mix over the next few years via lifetime extensions and restarts.
- Large industrial users in Europe are looking to reduce their gas via substitution. For example, refineries are substituting natural gas for LPG and naphtha, where possible. APEC members should investigate the potential for gas reductions.
- Alleviating the material constraints facing integral inputs to the hydraulic fracturing process, particularly steel and cement, would enable service companies to respond more favourably to high price signals and encourage oil and gas producers to invest more of their record cash flows in production capacity. Furthermore, APEC members could use their strategic petroleum reserves to guarantee a market and price for oil producers and offset the uncertainty stemming from the potential deleterious market impacts of reducing oil usage en route to carbon neutrality.
- A case study of Singapore's use of chartering a floating storage and regasification unit (FSRU) and a floating storage unit (FSU) to increase its regasification capacity and its storage capability during a period of supply disruptions.
- A case study of Singapore, Korea and Japan will illustrate how government intervention may be required to ensure that gencos and other large gas users have enough gas supply to meet their contractual obligations in times of significant disruption.
- China's evolving policy to reduce oil product exports is reducing the global supply of middle distillates as global demand continues to rebound from the pandemic. With refinery margins particularly elevated, it may be in the best interest of other APEC members to extend the life of existing refineries to mitigate the impact of this lower Chinese product supply.

## Conclusions

This paper highlights several short-term actions that APEC members can take to reduce the cost of oil and gas supply disruptions. However, there may be limits or hurdles to executing these short-term actions. Further investment, not only in oil and gas supplies, but into the supply chains that enable these actions, may be required to enable further short-term mitigation measures through this and other energy crises.

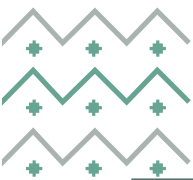
## References

Asia Pacific Energy Research Centre, APEC Energy Demand and Supply Outlook 8th Edition [scheduled to be published in October 2022]

Asia Pacific Energy Research Centre, Oil and Gas Security Studies 19: the Impact of the Energy Transition on Oil and Gas Security [scheduled to be published in 2022]

BP, Statistical Review of World Energy 2022 | 71<sup>st</sup> Edition, <https://www.bp.com/content/dam/bp/business-sites/en/global/corporate/pdfs/energy-economics/statistical-review/bp-stats-review-2022-full-report.pdf>



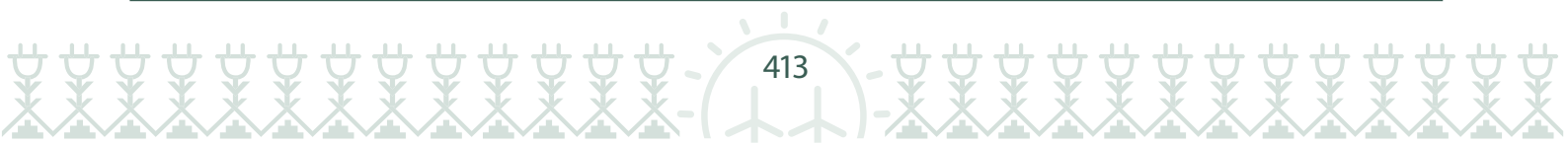


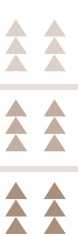
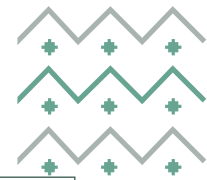
## **Impact of the Global Energy Transition on Hydrocarbon Economies**

Osamah Alsayegh  
Energy & Building Research Center  
Kuwait Institute for Scientific Research  
P.O. Box 24885 Safat, 13109 Kuwait  
[osayegh@kisir.edu.kw](mailto:osayegh@kisir.edu.kw)

### **Abstract**

So far, the focus has been on realizing policy, market, and technology requirements to facilitate energy transition toward decarbonization. However, little attention has been directed to the political economy and geopolitical impacts of the energy transition on net-exporting hydrocarbon countries to ensure an effective conflict-free global energy transition. Focusing on the Gulf Cooperation Council (GCC) countries as a case study, this paper analyzes the energy transition's impact on their internal and external affairs. The adopted methodology in achieving the paper's goal is as follows: reviewing the world energy supply historical trends for realizing energy security and transition; assessing the GCC region's contribution to the global energy demand; utilizing Bertelsmann Transformation Index to analyze the GCC's level of domestic socioeconomic and political stability under an energy transition scenario; examining the regional geopolitical events to infer the roles of the world's major players in the GCC region. Concluded analysis implies that the oil and gas sectors are well rooted within the global economy. Hence, they will continue to be a major part of the energy system for several decades. Under a low oil demand environment, the GCC could maneuver to stabilize socio-political affairs given their well-established state's power structure and sovereign wealth funds income. Furthermore, analysis shows that the current movement of the energy transition has opened the door for new major players in the GCC region.





[PAPER/POSTER TITLE

**Technical Constraints, Cost Risks and Failure Modes of the Energy Transition**  
(*Implications for Energy Security and Guidance for Policymakers*)

*Lucian Pugliesi, et al*  
*President, Energy Policy Research Foundation, Inc.*

**Overview**

To achieve a global net zero outcome, a wide array of technical and resource challenges must be overcome. No single technological constraint provides a path forward, but instead, a broad and difficult set of challenges must be addressed. Drawing upon work from a two-year assessment by the Energy Policy Research Foundation, Inc. (EPRINC) analysis team, the paper examines a broad array of technical constraints, cost risks, and likely failure modes in proceeding with a worldwide energy transition over the next 30 years. Solving a long list of technical challenges across a broad range of energy systems and fuel use and then scaling the solutions worldwide presents formidable challenges largely unappreciated within the technologically advanced OECD. The technical and scale challenges are not well understood. The net zero does not require solving a technical challenges to achieve a narrow and specific objective, but instead, broad solutions and technical breakthroughs are required across the entire energy system. The scale challenge is best described by Mark Mills in his book *The Cloud Revolution*: “The energy transition is not like putting a man on the moon. It is more like putting all of humanity on the moon—permanently.”

**Methods**

Achieving deep decarbonization requires rapid cost reductions in zero-carbon or negative-carbon technologies in all sectors of the economy. Private sector companies, NGOs, and intergovernmental organizations have presented widely different global cost estimates for transitioning to a net zero carbon emission (NZE) economy. The consulting firm McKinsey has estimated that worldwide 8 percent of GDP must be dedicated to the transition to achieve net zero worldwide by 2050. The EPRINC research identifies regions with the most rapid requirements for energy use (including likely energy use from population growth, economic expansion, and capital formation) over the next 30 years. In the absence of massive and sustained decarbonization the developing world, even if the entire OECD achieves net zero carbon emissions, worldwide CO2 emissions in 2050 are likely to only be 20% less than in a range of reference scenarios. The research identifies the key technologies that must be developed and deployed along with their likely technical risks and cost constraints. Land use requirements and technology limits are evaluated to determine the capacity for deployment (technology readiness level) of net zero technologies.

**Results**

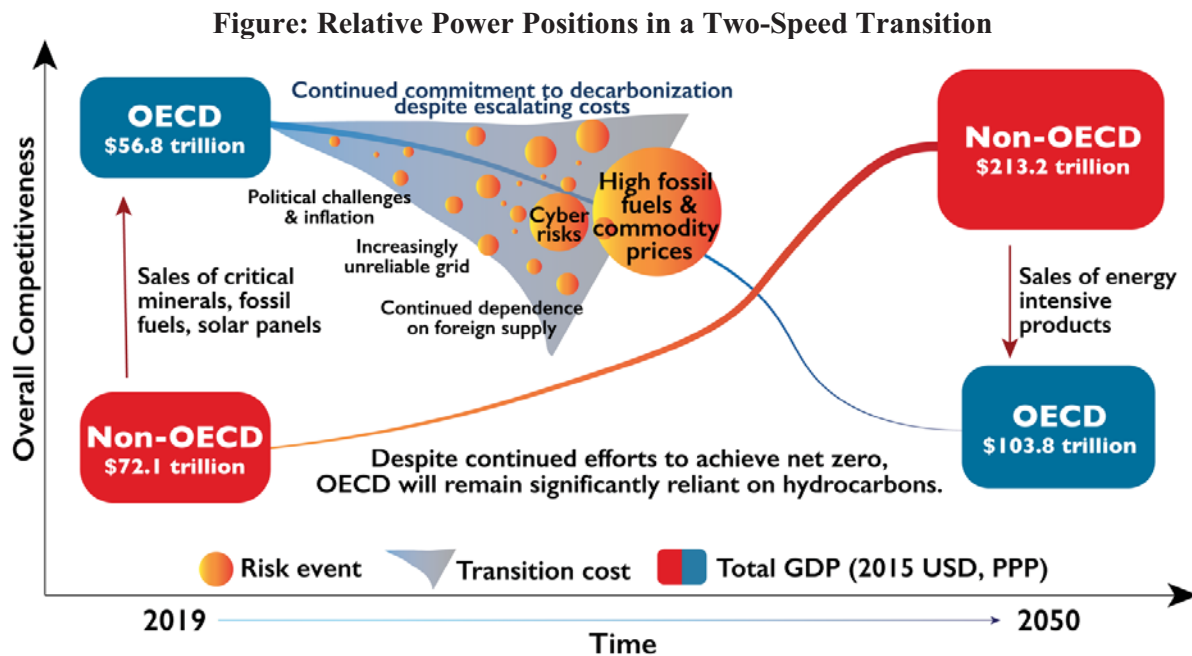
Cost and technology risks will see the world divided along two tracks. The first group of countries will consist primarily of the existing members of the Organization for Economic Cooperation and Development (OECD), a group of 38 high-income economies. Most OECD countries will stay committed to some degree of decarbonization despite escalating costs from high fuel and commodity prices, risks of an increasingly unreliable and vulnerable grid, political challenges, and continued dependence on foreign energy supply. By 2050, much of the OECD will make some and possibly significant progress in diversifying their energy mix, but the high energy growth regions will remain largely reliant on hydrocarbons. This outcome also presents a wide array of new energy security risks for the developed world as critical minerals and materials needed for the transition will largely be sourced outside the OECD.

**Conclusions**

The two speeds of transition will leave the OECD countries in a disadvantaged position while strengthening the relative power position of non-OECD countries. The combined GDP of the OECD will have nearly doubled in real terms by 2050, but the non-OECD economies will have almost tripled in size during that period. The total share of the existing OECD countries will have decreased from 44% to less than a third of the global economy by 2050. In this scenario, non-OECD countries will extend their energy technology dominance to more high-value technology components while tightening their grip on conventional energy supplies. Even with unsatisfactory progress and compromised energy security systems, experience dating back to the Kyoto Protocol suggests that OECD will continue with its aspirational goals. As shown in Figure xx, future responses to future challenges are likely to be the same as before: commitments to greater ambition but little change in emissions trend.



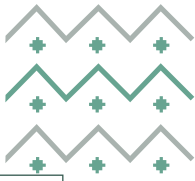




Source: EPRINC analysis

### References (partial list)

- APERC. APEC Outlook Annex I: Modelling Assumptions & Methodologies (2019). [https://aperc.or.jp/file/2019/5/30/APEC\\_Outlook6th\\_Annex+I\\_Modelling+assumptions+and+methodologies.pdf](https://aperc.or.jp/file/2019/5/30/APEC_Outlook6th_Annex+I_Modelling+assumptions+and+methodologies.pdf)
- Bouckaert et al., Net Zero by 2050 (2021). <https://www.iea.org/reports/net-zero-by-2050>
- BP, BP Energy Outlook (2022). <https://www.bp.com/en/global/corporate/energy-economics/energy-outlook.html>
- BP. Statistical Review of World Energy (2022). <https://www.bp.com/en/global/corporate/energy-economics/statistical-review-of-world-energy.html>
- Broom, D., "What's the price of a green economy? An extra \$3.5 trillion a year." World Economic Forum. <https://www.weforum.org/agenda/2022/01/net-zero-cost-3-5-trillion-a-year/>
- Climate Action Tracker. Countries and China sections (Assessment last updated on May 19, 2022). <https://climateactiontracker.org/>
- Earth Policy Institute Data Center. [https://www.earth-policy.org/data\\_center/](https://www.earth-policy.org/data_center/)
- Energy Transitions Commission. Mission Possible: Reaching net-zero carbon emissions from harder-to-abate sectors (Nov 2018). <https://www.energy-transitions.org/publications/mission-possible/#download-form>
- Fare, R., Renewable Energy Intermittency Explained: Challenges, Solutions, and Opportunities. Mar 11, 2015. <https://blogs.scientificamerican.com/plugged-in/renewable-energy-intermittency-explained-challenges-solutions-and-opportunities/>



## ***THE RUSSIAN INVASION OF UKRAINE AND THE INTERESTS OF THE GCC OIL PRODUCERS***

Nikolay Kozhanov, Gulf Studies Center, Qatar University, [n.a.kozhanov@gmail.com](mailto:n.a.kozhanov@gmail.com), +97431360872

### **Overview**

The paper is to argue that, while the US, EU and their partners managed to limit Russia's capacities to export its oil, the Arab monarchies of the Persian Gulf are not necessarily to only benefit from the situation. On the contrary, the changes caused by the transformation of the global oil market under the influence of the Putin's war in Ukraine can bring certain challenges for them.

### **Methods**

The analysis of the available statistical data on the oil production and trade; macroeconomic and fiscal indicators of the GCC countries; and the dynamics of their change.

### **Results**

The Ukraine war moved the focus of international community from security of demand towards security of supply by making the Western countries see the GCC oil producers as potential replacement for Russia at the European energy market and beyond. In other words, the Ukrainian war presented the Gulf with a rare opportunity to enrich. High oil prices boosted by the Russian aggression against Ukraine not only replenish oil producers coffers emptied by COVID but positively affect their macroeconomic growth indicators. The necessity to leave Russia also makes the IOCs reconsider their presence in the Gulf region promising more active interactions with the local NOCs.

On the other hand, Moscow is trying to redirect its export flows to the Asian region, the traditional consumer market of the GCC countries. This, in turn, increases the intensity competition there: cheap, albeit toxic, Urals that is traded at the historical high discount has already attracted the attention of the Indian and Chinese consumers. The unwillingness of the Gulf producers to cooperate with oil consumers in order to slow down or even reverse the growth of oil prices makes the consumers seek for the alternative ways to change the situation in their favor. The range of potential responses is wide and it varies from the search for alternative suppliers outside of the Gulf to the adoption of the legislation negatively affecting the activities of the OPEC+.

### **Conclusions**

The impact of the Ukrainian crisis on the domestic energy and economic security of the Gulf state is not as positive as in the case of their oil exports. The GCC economies have different level of tolerance towards the negative outfalls of the war such as rising fuel prices, high inflation rates and growing cost of inputs. Yet, even the least vulnerable economies such as that of Saudi Arabia or the UAE started to feel the negative pressure of rising fuel prices and energy cost. The high oil incomes also slow down the growth of nonoil sector of the Gulf economies and make them less interested in the implementation of diversification programs. In the long run, this impact will only be growing, potentially making the Gulf players to reconsider their market strategies.





## [ENERGY SECURITY IN MEXICO]

Emily Medina, Asia Pacific Energy Research Centre, +52-1-999-968-1568, emily.medina@aperc.or.jp

### Overview

In Mexico, increased energy demand across different sectors is increasing dependence on energy imports, particularly refined petroleum products and natural gas. This is primarily driven by a decline in domestic energy production. The widening gap between energy demand and supply threatens Mexico's energy security. This paper examines energy demand and supply growth, energy trade, and energy mix projections from the 8th edition of the APEC Energy Demand and Supply Outlook to identify energy security risks in Mexico.

### Methods

The 8th Outlook modelling involves decomposing the APEC energy system into multiple subcomponents spanning demand sectors (such as industry, transport, and buildings), transformation (power, heat, and refining), and supply (production and trade). Demand sector modelling relies on estimates of output, energy efficiency, fuel switching rates, activity rates, technology diffusion, and multiple other variables. Calibration occurs via knowledge-based iteration, particularly with economy-level experts. When demand is finalised, the power, heat, refining and supply, sector models deliver the required energy based on assumptions about fuel cost trajectories, and policy/market intervention. In the case of the power sector, a least cost model is deployed. However, cost-based decisions and assumptions are overridden if there is political backing for certain technologies or fuels that enhances their relative economic viability. There is frequent iteration of results, with extensive review and input from economy and energy experts to arrive at final energy demand, transformation, and supply results.

The Reference (REF) scenario is based on recent trends in APEC energy consumption, production, and trade, and assumes continuation of currently enacted policies. The Carbon Neutrality (CN) scenario explores hypothetical pathways for each of the 21 APEC member economies to reach carbon neutral energy sectors. The Carbon Neutrality scenario (CN) explores additional energy sector transformations such as increased levels of energy efficiency, behavioural changes, fuel switching, and CCS deployment. The pathways are constructed based on the unique characteristics, policy objectives, and starting points of each economy. The CN scenario does not consider CO<sub>2</sub> emission sinks, such as land-use or technologies like direct air capture.

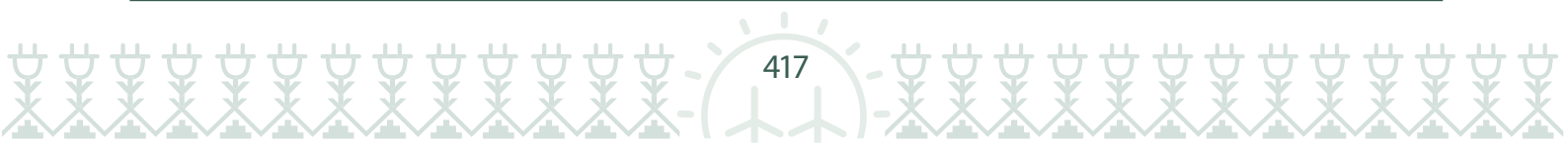
Since President Lopez Obrador took office in December 2018, there have been policy changes that have affected the outcome of the energy reform and have led to a different oil and gas production path in Mexico. Therefore, a third scenario "Current Policies" will also be included in this study. The results of Current Policies scenario are not yet available at the time of writing this abstract.

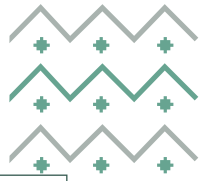
### Results

Mexico is one of 21 economies that comprise the Asia Pacific Economic Cooperation (APEC) forum. It is the 15th largest economy in the world and the seventh largest economy in the APEC region (World Bank 2020). Mexico's gross domestic product (GDP) grew at a compound annual growth rate (CAGR) of 2.0% between 2000 and 2019, reaching USD 2 513 billion. Mexico has a population of 127 million people, it is the 11th most populated economy in the world, and the sixth most populated economy in the Asia Pacific Economic Cooperation (APEC) region.

#### Oil

In REF, crude oil production increases by 21% from 2020 to 2030. After 2030, production follows a declining trend that can be explained by a long-term decrease in global demand and a discontinuation of oil auctions. In CN, Production falls by 45% from 4 424 PJ in 2018 to 2 451 PJ in 2050.





In REF, the level of crude oil exports decreases at a CAGR of  $-1.2\%$  from 2018-2050. In CN, crude oil exports fall by three-quarters from 2 765 PJ to 681 PJ for the same period. The fall in CN crude oil and natural gas liquids exports is much larger than the 42% fall that occurs in REF.

In 2050, crude oil consumption in CN is 38% lower than in REF. The CN projects a phase-out of refined products for power generation by 2041.

In REF, from 2030 to 2050, domestic refined production maintains a level of close to 2 200 PJ. Total refined products imports account for almost two-thirds of domestic consumption through most of the projection period.

In CN, increased electrification in the transport sector significantly reduces the demand for refined products. By 2050 in CN, transport sector consumption of refined products is only two-fifths of the level of consumption in REF. Transport sector consumption of refined products halves through to 2050 in CN. The falling demand means that almost all of Mexico's demand for refined products is satisfied by its domestic refineries. Imports of refined products fall by 95% through the projection period. Even with increased electrification in transport, reliance on refined products, such as gasoline and diesel, remains substantial through to 2050. In CN, the transport sector still consumes more than 1 150 PJ of refined products in 2050.

### Gas

In REF, Natural gas consumption in the power sector will more than double by 2050 with respect to 2018 levels. Industry consumes 68% more natural gas in 2050 than in 2018. By 2050, 83% of the 5 063 PJ of natural gas consumed in Mexico will be imported.

In CN, natural gas consumption peaks in the 2020s before tapering to a level that is only one-third of the consumption level in REF: 1 789 PJ compared to 5 063 PJ in 2050. By 2050, the power sector only consumes a 38% share of natural gas in Mexico, whereas the share is 68% in REF. From 2018 to 2050, industry and buildings sector natural gas demand grow by 12% and 56%, respectively.

In CN, natural gas production is 64% lower in 2050 than in REF. Most of the domestic demand for gas is met with imported gas (87%), coming mostly from the United States (90%). Even with the high import dependence, the energy content of natural gas imports is 2 650 PJ (63%) lower in 2050 than in REF.

### Conclusions

Mexico's oil production has been on a steady decline for the past decades. The REF scenario projects the largest increase in production. Nevertheless, even in this scenario it will still be insufficient to meet growing demand for refined products. As a result, oil exports are expected to decline in both scenarios. While at the same time, total refined product imports in REF will remain high, accounting for almost two thirds of domestic consumption and increasing Mexico's oil import dependency.

In CN, increased electrification in the transport sector reduces demand for refined products. Although fossil fuels still account for a large share of total primary energy supply, net oil import dependence is reduced.

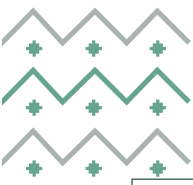
In terms of natural gas, Mexico has a high net import dependence that will further increase due to a rise in power and industry sector demand in both scenarios. In CN, natural gas imports reduce with new capacity additions of wind and solar generation.

The Current Policy scenario seeks to provide an updated short- and long-term view of Mexico's energy sector. It will consider the current policy approach of achieving energy self-sufficiency and increasing state influence and control over the energy sector. This paper will analyse how the current policies and market trends are affecting and will continue to affect energy security, and what future opportunities and challenges are likely.

### References

Asia Pacific Energy Research Centre (2022), APEC Energy Demand and Supply Outlook 8th Edition





## QUANTIFYING ENERGY SECURITY RISKS IN SOUTHEAST ASIA

Glen E. Sweetnam, Asia Pacific Energy Research Centre, +1-240-599-6672, glen.sweetnam@aperc.or.jp

### Overview

Seven of the member economies of the Asia Pacific Economic Cooperation (APEC) forum are located in Southeast Asia.<sup>1</sup> In 2020, these economies had a population of 590 million and accounted for over 90% of the region's energy use. These seven economies are widely expected to achieve rapid economic growth over the next three decades. Their energy use is also expected to grow rapidly. Although most have committed to ambitious energy efficiency and decarbonization strategies, the APEC Energy Demand and Supply Outlook 8<sup>th</sup> edition (APEC Energy Outlook) projects their total energy requirements will still grow by 76-112% between 2020 and 2050. In addition, their need for oil and natural gas is also expected to remain substantial throughout the period. Quantifying the energy security risks associated with their growing energy use and continued import dependence will be beneficial to these governments as they work to craft balanced policies to achieve simultaneously their economic, environmental, and energy security goals.

This paper will quantify the costs of potential future oil and natural gas supply disruptions using estimated values of those key parameters that determine the economic costs of fuel supply disruption. When weighted by the likelihood of future supply disruptions, economies in Southeast Asia can use these cost estimates to evaluate the benefits of programs designed to enhance energy security.

### Methods

Energy security, resilience, and grid reliability refer to the provision over time of uninterrupted energy supplies to consumers at a reasonable cost regardless of supply disruptions caused by natural and man-made disasters. Because modern economies demand substantial quantities of energy and that demand is relatively price inelastic, supply disruptions can impose substantial costs on an economy. Depending on the characteristics of an economy's energy system, changes in energy demand, import dependence, and the mix of energy types (fuels, electricity) can impair or enhance energy security, resilience, and grid reliability.

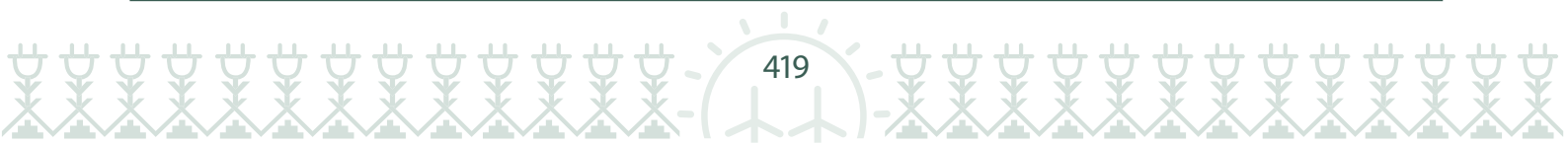
The following formulation describes the key drivers of the costs of a supply disruption in fuel  $f$  to economy  $e$ :

**Cost** =  $f(Q_f, I_f, R_f, E_{d,e}, E_{s,e}, E_{d,g}, E_{s,g})$ , where:

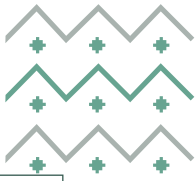
- $Q_f$  = quantity of fuel  $f$  in economy  $e$
- $I_f$  = quantity of fuel  $f$  imported into economy  $e$
- $R_f$  = strategic reserve (stockpile) of fuel  $f$
- $E_{d,e}$  = demand price elasticity of fuel  $f$  in economy  $e$
- $E_{s,e}$  = supply price elasticity of fuel  $f$  in economy  $e$
- $E_{d,g}$  = global demand price elasticity of fuel  $f$
- $E_{s,g}$  = global supply price elasticity of fuel  $f$

The APEC Energy Outlook provides estimates of the total consumption and import quantities of each fuel in each economy's energy mix from 2020 – 2050 for two scenarios: a Reference (REF) case and a Carbon Neutrality (CN) case. The Reference (REF) scenario is based on recent trends in APEC energy consumption, production, and trade, and assumes continuation of currently enacted policies. The Carbon Neutrality (CN) scenario explores hypothetical pathways for each of the 21 APEC member economies to reach carbon neutral energy sectors. The Carbon Neutrality scenario (CN) explores additional energy sector transformations such as increased levels of energy efficiency, higher investment in renewable power generation, behavioural changes, fuel switching, and CCS deployment. The pathways

<sup>1</sup> Brunei, Indonesia, Malaysia, Philippines, Singapore, Thailand, Viet Nam







are constructed based on the unique characteristics, policy objectives, and starting points of each economy. The CN scenario does not consider CO<sub>2</sub> emission sinks, such as land-use or technologies like direct air capture.

The estimates of own-price elasticities for each fuel will be based on literature reviews. The strategic stockpile estimates will come from public sources.

## Results

The seven APEC member economies in Southeast Asia are expected to be some of the most dynamic in the world over the next three decades. The APEC Energy Outlook calls for the aggregate GDP of this group to more than triple in real terms over the next 30 years (2018 USD PPP). As a result, total primary energy requirements in these economies also exhibit substantial growth: growing by 112% by 2050 in REF and by 76% in CN.

Due to growth in energy demand, oil consumption in Southeast Asia is expected to remain substantial even if ambitious decarbonization policies are implemented. Over the next 30 years, oil consumption is expected to grow by 36% in REF. In CN, oil consumption declines by only 17% from the 2020 level. As a result of strong demand growth and declining indigenous oil production, the volume of net oil imports in Southeast Asia increases by 52% in REF and declines by only 5% in CN despite higher deployment of renewable power generation. As a result, Southeast Asia is the only APEC region where oil import dependence increases: from 58% in 2020 to 74% in REF and 70% in CN. This high oil import dependence means that oil supply security will remain a top priority for Southeast Asia.

In aggregate Southeast Asia is a net gas exporting, but starting in the mid-2020s, the region's gas imports are expected to exceed its exports. The region's transition from a net gas exporter to a gas importer brings new energy security risks. Over the next 30 years, Southeast Asia accounts for the second largest regional increase in net natural gas imports due to a decline in domestic gas production and fuel switching from coal to gas. The region goes from exporting 638 PJ in 2020 to importing 515 PJ in 2030. By 2050, imports increase an additional 10 000 PJ. Even in CN, net gas imports in Southeast Asia follow an upward trajectory. In 2050, Southeast Asia natural gas import dependence is expected to be 61% and 55% in REF and CN, respectively.

In addition, to continued dependence on oil and gas imports for substantial portions of its energy supply, the region's energy system will become less diversified and more brittle as the share of renewable power generation grows. The associated reduction in supply and demand elasticity will also raise the economic losses associated with oil and gas supply disruptions, if and when they occur.

The estimated economic losses suffered by each of the seven APEC economies in Southeast Asia as a result of potential future oil and gas supply disruptions will be included in the final paper.

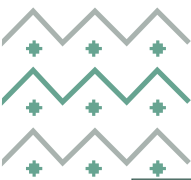
## Conclusions

The rapid economic growth and surging energy demand in the seven largest Southeast Asia economies will raise serious energy security concerns. The growing dependence on oil imports in REF and continued substantial oil import dependence in CN and the growing dependence on gas imports in both scenarios will increase energy security risks for the region. When these factors are combined with reduced fuel diversity and lower supply and demand elasticities the vulnerability of the region to energy supply disruptions rises. The quantification of the costs of future oil and gas supply disruptions will assist policymakers as they work to strike the appropriate balance among programs designed to achieve their goals of economic growth, environmental stewardship, and energy security.

## References

- Asia Pacific Energy Research Centre (2022), APEC Energy Demand and Supply Outlook 8th Edition
- Carol Dahl, OPEC Review, May 2008, A Survey of Oil Demand Elasticities for Developing Countries





## Structural and policy drivers of the EU energy crisis: Exploring their nexus beyond current exogenous shocks

Roberto Cardinale  
Department of Economics  
School of Business  
The American University in Cairo  
Roberto.cardinale@aucegypt.edu

### Overview

Natural gas is an important source in the energy mix of both advanced and emerging economies and a driver of industrial and economic development. The recent surge in prices worldwide comes against the belief emerged in recent years of the definitive advent of an era of low gas prices. This is likely to have substantial repercussions on the dynamics of development and on the welfare of many countries, particularly if they are large consumers and importers, as in the EU. While agencies and analysts are attributing the causes of the current energy crisis in the EU mainly to a temporary convergence of exogenous shocks, for example the post-covid economic recovery and the war in Ukraine, this article identifies also long-term structural and policy factors endogenous to the energy sector. This is done by exploring the causal relation between liberalization reforms and trends in gas supply in three major gas markets – UK, US, and EU. Through the lens of Transaction Cost Economics, the paper finds that domestic production of energy is a key factor determining the success of policies for market competition, price affordability and energy security. All the three cases show that although liberalization is effective for reducing prices in times of gas abundance, it causes the opposite effect in times of scarcity. This suggests that in contexts of domestic scarcity and high dependence from imports, such as in the EU, policy should contemplate the coexistence of models based on both market competition and vertical integration to take advantage from low spot prices in periods of international abundance and contain the surge in periods of scarcity.

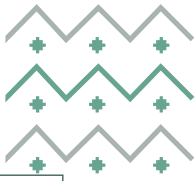
### Methods

The paper adopts the methodology of the comparative case study (see Collier, 1993; Dion, 2003; Flick, 2006; Yin, 2009). The selection of the cases – UK, US, EU – follows Dion's (2003) criteria, which suggest that cases should be selected based on similarities on the variables to control for and on differences in the variables under investigation. In this paper, the countries selected have all mature and large natural gas markets, while more importantly, their liberalization reforms are in an advanced stage (comparing to other relevant gas markets worldwide). The variable under investigation is how the effectiveness of liberalization reforms (associated with low domestic gas prices) changes at different levels of domestic supply, with the EU being characterised by domestic scarcity, the US by abundance, and the UK having transitioned from abundance to scarcity.

### Results

The UK, US and EU cases suggest that in conditions of gas oversupply, liberalization policies can successfully achieve the objectives of enhancing market competition and reducing final prices. However, it is necessary to clearly define the causal relationship between the two key factors – abundance of gas and infrastructure in relation to liberalization policies – and their respective influence on price reduction. In fact, the abundance of gas is an essential condition for the virtuous functioning of a competitive market. Without it, there would be no room for new competitors to increase their market share at the expense of established companies by offering lower prices to consumers.





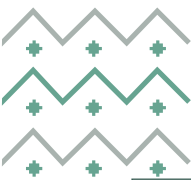
## Conclusions

The current worldwide surge in natural gas prices is hitting mainly import dependent countries, first and foremost in the EU. This comes against the belief emerged in recent years of the definitive advent of an era of low energy prices, brought about by increasing market competition and diversification towards renewables. The current supply shortage seems to have caught the EU unprepared and still in a transition stage in its path towards a more competitive and green energy market, suggesting that reforming the energy sector in the EU cannot overlook one of its defining features: the persistence of a strong dependence from imports. Drawing from the experience of policy reforms adopted in the major world gas markets, the paper shows why liberalization is effective for reducing prices in periods of oversupply, while its benefits are offset in periods of shortage, such as the current one. The paper suggests immediate actions to overcome the current crisis and long-term policy directions to pursue price affordability and energy security

## References

- Collier, 1993. The Comparative Method. In A. W. Finifter, ed. Political Science: The State of the Discipline II. Washington D.C.: American Political Science Association.
- Dion, D., 2003. Evidence and Inference in the Comparative Case Study. In Necessary Conditions: Theory, Methodology, and Applications. Rowman & Littlefield, pp. 95–112.
- Flick, U., 2006. An Introduction to Qualitative Research, London; Thousand Oaks; New Delhi; Singapore: SAGE Publications.
- Yin, R., 2009. Case Study Research: Design and Methods, Thousand Oaks, Calif.; London: SAGE Publications





## ***ON THE GEOPOLITICAL DISRUPTION OF THE EU NATURAL GAS MARKET: A CORRECTION MODEL***

Pierluigi Nichilo, dual degree Master of Science student in Mineral and Energy Economics at Colorado School of Mines and Petroleum Economics and Management at IFP School, +1 (720) 755-4099, pnichilo@mines.edu

### **Overview**

WWII end called Europe for stability. The institution of the European Union (EU), followed by the advent of the euro roughly 20 years ago, are the best expressions of such will. Policies and regulations to boost the economy were set. The current consequences of the abrupt breach of the European continental security suggest that most of them were conceived assuming peace to hold the continent together.

Natural gas consumption arose  $\approx 30\%$  in the EU and  $\approx 50\%$  worldwide in the last 30 years. Its greater impact on geoeconomic equilibria also highlights many drawbacks: reliance on politics and a complex spacial structure, affected by relatively high transportation costs, long-term contract implications and significant CapEx expenditures. These factors are now antagonist of a reliable and stable European gas network.

The EU Directive 98/30/EC (quite as old as the euro) institutionalized the need for it. Measures implemented to avoid dominant detrimental market positions rather prioritized competitiveness, security and quality of supply. Breaching these principles affects several economic activities relying on gas, threatening: the strength and stability of the euro, consumers' investments and ROIs, the EU leading role in decarbonization, public security. Meaningfully, the second largest reserve currency in the world hit a 20-year low after Gazprom declared would shut down Nord Stream 1 pipeline! The importance of present events in contemporary and future energy geopolitics are the reasonable for this paper.

### **Methods**

Correlations between data will be investigated: gas prices, import quotas, electricity and industrial heat production by energy source, currency fluctuations against energy prices, trade movements (pipelines and LNG), CapEx expenditures, storage and transportation costs. Statistics related to the EU of the last 30 years will be the benchmark for data analytics. The relative weight of each factor determining gas prices to be first ordinarily assessed, and then geopolitical disruptions to be accounted for.

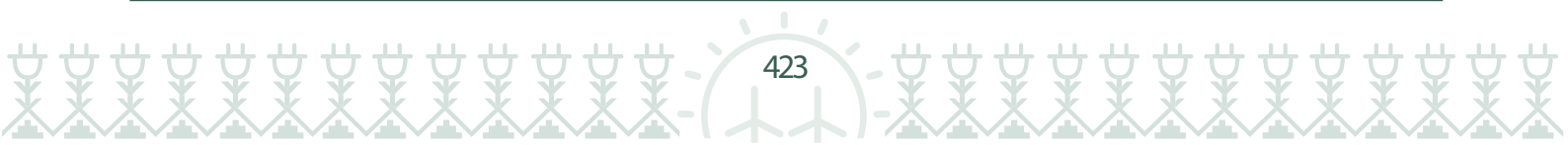
The severity of the unrest on the overall economy will be estimated by a parameter inferred from historical data during specific events (i.e. the EU agreement on the sixth sanctions package covering the import of crude oil from the Russian Federation that triggered the rally of the Dutch TTF Gas Futures). It will in turn be correlated to gas prices and exchange rates.

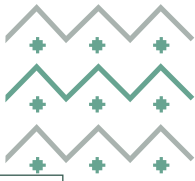
### **Results**

Established correlations, a set of optimal and hypothetical data will be the new input for the model, based on an example of ideal reallocation of CapEx expenditures within the energy infrastructural network, accounting for: rerouting gas supply, enhanced cooperation with MENA and INOGATE exporters, strengthened LNG networks, enhanced hydrogen production, higher quotas of electricity produced from renewable resources. The competitive advantages observed in countries leading the green revolution, will be supposed to hold across the whole EU. The results of the model given the present real scenario will be compared against the same values for the suggested correction modelled scenario. They will provide prices patterns estimates for the nearby future.

### **Conclusions**

The geoeconomic spacial model will demonstrate that weaponizing implications of energy supply may be strategically bypassed, while consistently achieving objectives as monetary stability and environment preservation. The paper will contribute to the mission of the 44th IAEE international conference, showing that pathways to a clean, stable, and sustainable energy future are also the gateway to support geopolitical stability and social wealth.





## *Competing Interests: Energy Transition, Energy Security and Energy Justice*

Dr Slawomir Raszewski, University of East London, +487421352455, [s.raszewski@uel.ac.uk](mailto:s.raszewski@uel.ac.uk)

Dr Eduardo G. Pereira, University of West Indies, +5511988649550 [egp.portugal@gmail.com](mailto:egp.portugal@gmail.com)

Dr Ngozi Chinwa Ole, African Centre of Excellence for Water and Environmental Research, +2349058180417, [olengozi@gmail.com](mailto:olengozi@gmail.com)

### **Overview**

Each country should deal with the main priorities and challenges which are directly related to its own economic, social and geopolitical background. It is clear that climate change affects societies and the planet as a whole. Yet, the pace and effort each country is capable of to commit towards a sustainable future still varies significantly. Given that less than half of the African continent still lacks access to electricity, the pressing question is how can energy justice be realised to meaningfully and equitably contribute towards energy transition? With the energy transition debate closely aligned with emissions and decarbonisation targets there is an uncomfortable truth – supported by statistical data – of wide disparity in carbon emissions between the poorest nations and the ‘global north’, as well as the industrialising nations of Southeast Asia (Heil and Wodon 1997; Chancel 2022). This is a key ethical challenge underlying the climate efforts of the annual Conference of the Parties (COP). Equally, energy security is a common concern on all nations as it affects both poor and rich economies, and is a key policy challenge for the ‘here and now’ The ongoing crisis in eastern Europe has demonstrated that energy security, understood as the availability of sufficient supplies at an affordable price (Yergin 2006), might well prevail over an energy transition, as demonstrated by EU policies and actions over recent months to reduce, and gradually replace its dependency on Russian natural gas supplies. However energy justice, conceptualised as the recognition of energy needs and the equal distribution of the benefits and burdens of energy systems (Sovacool 2014), might be a priority in developing nations with significant resources to be explored, with low-income nations most likely to depend on the development of these resources. These three competing concepts lead to the underlying questions of this paper (a) When does energy transition take priority? And (b) How can these competing interests be balanced? Energy transition is understood as a continuous unfolding of processes that gradually change the composition of sources used to generate heat, motion and light (Smil 2017).

### **Methods**

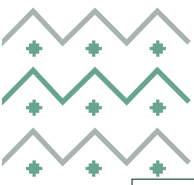
This paper seeks to address these two questions using a comparativist case study approach comprised of a selection of key developed economies and low-income nations, to understand the range of conditions that prioritise energy transition policy. Drawing on comparativist social approach (Przeworski 1970) the analysis serves the purpose of presenting the competing interests nations face in the wake of accelerated energy transition policy agenda.

### **Results**

The paper juxtaposes priorities against the interests at stake in, respectively, key developed economies and low-income countries. Drawing on Energy Transition (ETI) and Circular Carbon Economy (CCE) indices and a selection of relevant open access data, the paper compares and contrasts economies with low scores in the ETI, i.e. Iran and Nigeria, which are also key petroleum producing nations, and key regional economies of the EU, as well as the United Kingdom, Brazil and Mexico. The utility of indices is, as demonstrated by the CCE model, two-fold:







(a) to measure and compare 'strengths and weaknesses' and progress underway so far (b) adopt best practice approach to comprehensively study a policy problem and understand the choices at hand (Luomi, Yilmaz, Alshehri and Howarth 2021). Drawing on analysis of the data, the paper points out to key differences between groupings of nations which can be attributed to the type of economic path-dependence they exhibit. Consequently, nations leading on energy transition 'preparedness' tend to be developed economies with overall well-diversified energy security supply options. In contrast, the nations that rely heavily on fossil fuels-based economy, including through exports, tend to 'underperform' on the energy transition front.

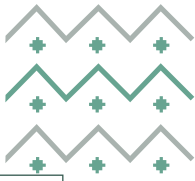
## Conclusions

The paper systematically analyses the nation groupings' priorities and the key challenges underpinning their economic, legal, social and geopolitical standing in order to generate key policy recommendations so as to better guide implementation of the energy transition. The paper provides a set of recommendations, drawn on careful data analysis, which are policy oriented and seek to alleviate the dilemma posed by forces of transition, security, and justice in the context of energy.

## References

- Chancel, L. (2022) 'Global carbon inequality over 1990–2019', *Nature Sustainability* 5, pp. 931–938. <https://doi.org/10.1038/s41893-022-00955-z>
- Heil, M. T., and Wodon, Q. T. (1997) 'Inequality in CO2 Emissions Between Poor and Rich Countries', *The Journal of Environment & Development*, 6(4), 426–452. <https://doi.org/10.1177/107049659700600404>
- Luomi, M., Yilmaz, F., Alshehri, T. and Howarth, N. (2021) 'The Circular Carbon Economy Index – Methodological Approach and Conceptual Framework', *The King Abdullah Petroleum Studies and Research Center (KAPSARC)*, May 2021. Doi: 10.30573/KS--2021-MP01. <https://www.kapsarc.org/file-download.php?i=86314>
- Przeworski, A. (1970) *The Logic of Comparative Social Inquiry*. New York: Wiley-Interscience.
- Smil, V. (2017) *Energy Transitions: Global and National Perspectives*, 2nd Edition Praeger: Denver, CO.
- Sovacool, B.K. (2014) 'What are we doing here? Analysing 15 years of energy scholarship and proposing a social science research agenda', *Energy Research and Social Science*, Vol. 1, pp. 1-29
- World Economic Forum (2021) 'Fostering Effective Energy Transition 2021 edition', Insight Report, April 2021. [https://www3.weforum.org/docs/WEF\\_Fostering\\_Effective\\_Energy\\_Transition\\_2021.pdf](https://www3.weforum.org/docs/WEF_Fostering_Effective_Energy_Transition_2021.pdf)
- Yergin, D. (2006) 'Ensuring Energy Security', *Foreign Affairs*, Vol. 85, No. 2, pp. 69-82.





## ***JAPAN-GULF ENERGY RELATIONS: DISCUSSING THE IMPACT OF THE RUSSIA-UKRAINE WAR***

Kazuto Matsuda, Gulf Studies Center, Qatar University,  
+974-3334-0502, kazuto\_matsuda320@yahoo.co.jp

### **Overview**

The Gulf states (i.e., Saudi Arabia, the United Arab Emirates, Kuwait, Qatar, Oman and Bahrain) and Japan have long been fostering cooperative hydrocarbon trade relations since the twentieth century (e.g., Abdullah & Al-Tamimi, 2015; AlShamsi & Kandil, 2001; Al-Tamimi, 2013; Calabrese, 2009; Janardhan, 2021; Nakajima, 2015; Niblock & Malik, 2013; Sharif, 1986). Today, the Gulf states are the primary exporters of hydrocarbons to the Japanese economy (Agency for Natural Resources and Energy of Japan, 2021). However, the February 2022 invasion of Ukraine by Russia, one of the world's major oil and natural gas producers, contributed to disruption in the global hydrocarbon supply chain, affecting the Western and Eastern economies. In spite of this, little has been discussed regarding its impact on the hydrocarbon relations between the Gulf states and Japan. In this light, this research aims to fill the research gap by qualitatively and quantitatively examining the impact of the Russia-Ukraine war on Japan-Gulf hydrocarbon relations. Its main research question is: To what extent did the Russia-Ukraine war impact the Japan-Gulf hydrocarbon relations?

### **Methods**

The research employs qualitative and quantitative analytical approaches to answer the above research question. These approaches include qualitative analysis of Japanese and Gulf governments' responses to the Russia-Ukraine war, including Tokyo's decision to release and sell Saudi and Emirati oil, domestically stockpiled in Japan under the Japan-Gulf joint oil storage projects since 2009, to stabilize its national energy earlier this year (Ministry of Economy, Trade and Industry of Japan, 2022). Moreover, the study conducts a comparative analysis of their hydrocarbon trade figures before and after the Russian invasion of Ukraine in February 2022 to quantitatively assess how the Russian invasion of Ukraine has impacted the hydrocarbon trade between Japan and the Gulf states.

### **Results**

The study finds at least the following:

1. The aforementioned Gulf oil, stockpiled domestically in Japan under the Japan-Gulf joint oil storage project, helped sustain Japan's energy security amid the disruption in the global hydrocarbon supply chain caused partially by the Russian invasion of Ukraine.
2. The Japan-Gulf hydrocarbon trade figures did not significantly fluctuate following the Russian invasion of Ukraine.

### **Conclusions**

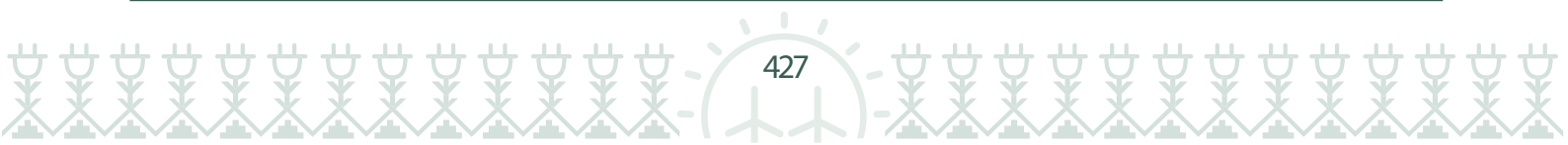
The impact of the Russia-Ukraine war on Japan-Gulf hydrocarbon relations is limited as the hydrocarbon flow between Japan and the Gulf states remained largely stable following the Russian invasion of Ukraine in February 2022.

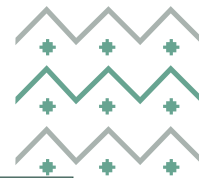




## References

- Abdullah, J. & Al-Tamimi, N. (2015). Japanese–Gulf Relations: What’s Next after Energy? *Al Jazeera Centre for Studies*. <http://studies.aljazeera.net/en/reports/2015/11/20151113125543544667.html>
- Agency for Natural Resources and Energy of Japan (2021). *Enerugii Hakusho 2021* [Energy Whitebook 2021]. <https://www.enecho.meti.go.jp/about/whitepaper/2021/>.
- AlShamsi, S. & Kandil, M. (2001). On the significance of trade relations between GCC countries and Japan. *Journal of Economic Integration*, 16(3), 344–368. <https://doi.org/10.11130/jei.2001.16.3.344>
- Al-Tamimi, N. (2013). Asia-GCC relations: Growing interdependence. *ISPI*, 179, 1–12.
- Calabrese, J. (2009). The consolidation of Gulf-Asia relations: Washington tuned in or out of touch? *Middle East Institute*. <https://mei.edu/publications/consolidation-gulf-asia-relations-washington-tuned-or-out-touch>
- Janardhan, N. (2021). Japan’s oil diplomacy in the Gulf: Old idea, new approaches. *Arab Gulf States Institute*. <https://agsiw.org/japans-oil-diplomacy-in-the-gulf-old-idea-new-approaches/>
- Ministry of Economy, Trade and Industry of Japan. (2022, April 2). *Minister Hagiuda Attends the IEA Extraordinary Ministerial Meeting* [Press release]. [https://www.meti.go.jp/english/press/2022/0402\\_001.html](https://www.meti.go.jp/english/press/2022/0402_001.html)
- Nakajima, I. (2015). *Sekiyu to Nihon: Kunan to Zasetu no Shigengaikoushi* [Oil and Japan: The History of Resource Diplomacy of Hardships and Setbacks]. Shinchousha.
- Niblock, T. & Malik, M. (2013a), eds. *Asia-Gulf Economic Relations in the 21st Century: The Local to Global Transformation*. Gerlach Press.
- Sharif, W. (1986), ed. *The Arab Gulf States and Japan: Prospects for Cooperation*. Routledge.





## FIRM INVESTMENT IN RENEWABLE ENERGY: AN EMPIRICAL EVIDENCE FROM THE PEOPLE'S REPUBLIC OF CHINA

Dina Azhgaliyeva, Asian Development Bank Institute, Tokyo, Japan, +81 3 3593 5566, dazhgaliyeva@adbi.org  
 Hai Le, Asian Development Bank Institute, Tokyo, Japan, (+81)8021363544, hvle@adbi.org

### Overview

Reductions in emissions of carbon dioxide and other greenhouse gases (GHG) must be achieved in the coming decades to avoid catastrophic global temperature rises. Limiting global warming to within 1.5° C will require rapid, far-reaching, and unprecedented changes in all sectors. GHG emissions in Asia and the Pacific now account for over 50% of the world's total.

Renewable energy technologies, considered one of the most effective ways to tackle climate change and global warming, have received increasing attention given their benefits of lower pollution and clean production. According to the 2021 global energy review of the International Energy Agency, renewable energy consumption expanded by 3% in 2020 due to a decrease in the demand for all other fuels. The main driver was attributed to a 7% expansion in renewable electricity generation. In 2021, electricity generation from renewable technologies is set to grow by more than 8% to reach 8300TWh, which is the rapidest year-on-year expansion since the 1970s.

The energy sector in developing Asia heavily depends on fossil fuels, and energy prices are often subsidized or government controlled. Therefore, huge investments are needed to promote clean and renewable energy. However, public expenditure in this region is tightly constrained, and this has been especially compounded by high COVID-19-related expenditures. Energy demand will continue to accelerate due to increased economic growth, population growth, and energy access, with developing Asia and the Pacific expected to account for two-thirds of global energy demand growth by 2040, according to the International Energy Agency (2019).

The People's Republic of China (referred to as PRC hereinafter), considered one of the world's largest energy consumers, has demonstrated rapid growth in renewable energy investments. According to 2022 energy transition investment trends of Bloomberg New Energy Finance, PRC's investment in energy transition increased by 60% from 2020 and reached \$266 billion in 2021, making them the leading country. Moreover, renewable energy investment accounts for the largest proportion of nearly \$130 billion, again cementing its top position.

Given the rapid growth in the number of new installed renewable energy projects and the diversification of sectors financing renewable technologies in PRC, this paper contributes to the literature studying investment decisions in renewable energy in developing economies using the case of PRC.

### Methods

We use the unique dataset of annual firm-level data from nearly 300 firms from PRC which invested in renewable energy projects in PRC during the period 2015-2020 from Bloomberg Terminal, Bloomberg New Energy Finance, and S&P Capital IQ pro database.

#### Baseline Econometric Models

We estimate the following reduced form investment equation to investigate the effect of financial variables on firm's renewable energy investment:

$$REI_{i,t}/K_{i,t} = \alpha + \beta_1 lev_{i,t} + \beta_2 rev_{i,t} + \beta_3 ROA_{i,t} + \beta_4 firmage_{i,t} + \beta_5 ln\ asset_{i,t} + \beta_6 energycost_t + \mu_i + e_{i,t}, (1)$$

where  $REI_{i,t}$  is the total amount of renewable projects' values invested by firm  $i$  in year  $t$ ;  $K_{i,t}$  is the working capital of firm  $i$ ;  $\alpha$  is a constant;  $lev_{i,t}$  is the financial leverage of firm  $i$ ;  $rev_{i,t}$  denotes the ratio of the total revenue to the total asset;  $ROA_{i,t}$  computed as the net income divided by the total asset indicates the return of asset;  $firmage_{i,t}$  demonstrates the age of firm  $i$  at year  $t$ ;  $ln\ asset_{i,t}$  is the log of total asset which captures the size of the firm;  $energycost_t$  measures the cost of renewable energy in the PRC in year  $t$ ;  $\mu_i$  captures the individual effect of firm  $i$ ;  $\beta_1, \beta_2, \beta_3, \beta_4, \beta_5,$  and  $\beta_6$  are the coefficients; and finally  $e_{i,t}$  denotes the error term.

#### Models with ESG Variables

We investigate the effects of Environmental, Social, and Governance (referred to as ESG hereinafter) variables on the renewable energy investment to working capital ratio. Specifically, we employ the following two types of ESG variables: (1) the external cost of air pollutants as a percent of the company's revenue and (2) the external cost of GHG emissions as a percent of the company's revenue.

$$REI_{i,t}/K_{i,t} = \alpha + \beta_1 lev_{i,t} + \beta_2 rev_{i,t} + \beta_3 ROA_{i,t} + \beta_4 firmage_{i,t} + \beta_5 ln\ asset_{i,t} + \beta_6 energycost_t + \beta_7 aircost_{i,t} + \mu_i + e_{i,t}, (2)$$

$$REI_{i,t}/K_{i,t} = \alpha + \beta_1 lev_{i,t} + \beta_2 rev_{i,t} + \beta_3 ROA_{i,t} + \beta_4 firmage_{i,t} + \beta_5 ln\ asset_{i,t} + \beta_6 energycost_t + \beta_7 ghgcost_{i,t} + \mu_i + e_{i,t}, (3)$$





where  $aircost_{i,t}$  and  $ghgcost_{i,t}$  denote the external costs of air pollutants and GHG emissions, respectively.

#### Models Incorporating COVID-19 Stringency Index

The restrictions applied by the government of PRC to tackle the COVID-19 pandemic might have negative influences on the installation of renewable energy projects. To incorporate the impacts of these restrictions, we present the following econometric model:

$$REI_{i,t}/K_{i,t} = \alpha + \beta_1 lev_{i,t} + \beta_2 rev_{i,t} + \beta_3 ROA_{i,t} + \beta_4 firmage_{i,t} + \beta_5 ln\ asset_{i,t} + \beta_6 energycost_t + \beta_7 aircost_{i,t} + \beta_8 stringency_{p,t} + \mu_i + e_{i,t}, \quad (4)$$

where  $stringency_{p,t}$  denotes the Covid-19 stringency index at province  $p$  and  $\beta_8$  is the associated parameter. This index is collected from the Oxford Coronavirus Government Responds Tracker (OxCGRT). To check the robustness of our results, we employ the dummy variable  $covid_{p,t}$  which takes value of 1 when  $t=2020$  and 0 otherwise.

### Results

The estimated results for our full models are presented in Table 1. The key findings of our study can be summarized as follows: First, we find that leverage plays a crucial role in firm investment in renewable energy. To be more specific, a high liability-asset ratio leads to an increase in corporate investment, and the effect is statistically significant at 5% level. The potential explanation is that financial leverage can equip enterprises with more financial budget in order to finance renewable projects. Second, we demonstrate that firm age has a positive impact on renewable investment to working capital ratio. This suggests that older firms with more years of experience tend to increase their investments in renewable technologies. Third, we find positive impacts of the external costs of both air pollutants and GHG emissions on the renewable energy investment to working capital ratio. In other words, enterprises with higher external costs of air pollutants and GHG emissions tend to increase their investments in renewable energy. Note also that the effects are statistically significant when we control for endogenous bias using the instrumental variables (IV) regressions. Due to space constraints, we do not report the estimated results of IV regressions. Finally, we find adverse effects of the COVID-19 stringency index on the renewable energy investment to working capital ratio regardless of whether we employ the external cost of air pollutants or the external cost of GHG emissions as a proxy for the ESG variable, and the effects are statistically significant. These findings confirm our hypothesis that the restrictions applied by the government of PRC to combat the COVID-19 pandemic negatively affect the installation of renewable energy projects.

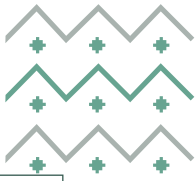
Table 1. Estimated results for models with Covid-19 variables

Dependent variable: REI/K				
rev	-0.710***	-0.710***	-0.707***	-0.707***
ln asset	-0.237***	-0.231***	-0.239***	-0.233***
ROA	-0.699	-0.694	-0.692	-0.687
lev	0.348**	0.350**	0.353**	0.354**
firm age	0.080*	0.078*	0.076*	0.075*
energy cost	0.006	0.006	0.005	0.005
aircost	0.001		0.001	
ghgcost		0.001		0.001
stringency	-0.002*	-0.002*		
covid			-0.089*	-0.086*
constant	1.594	1.531	1.724	1.660
Observations	349	349	349	349
R square	0.183	0.185	0.182	0.183

### Conclusions

This study investigates which firm characteristics play crucial roles in firm decisions to finance renewable energy projects. To this end, we employ a unique dataset from nearly 300 firms in PRC that invested in renewable energy technologies during the period 2015-2020. Our main findings can be summarized as follows: First, we indicate that both financial leverage and firm age have positive and highly significant impacts on the renewable energy investment to working capital ratio. Second, we demonstrate that the external costs of both air pollutants and GHG emissions positively affect the renewable energy investment to working capital ratio. Third, the restrictions implemented by the government of PRC to combat the COVID-19 pandemic have adverse impacts on the renewable energy investment to working capital ratio. Finally, our results are robust to various model specifications.





Conference Management Toolkit - Submission Summary

<https://cmt3.research.microsoft.com/IAEEConference2023/Submissio...>

## Submission Summary

**Conference Name**

44th IAEE International Conference - 2023

**Paper ID**

49

**Paper Title**

Financial Sector Development and Energy Poverty: Empirical Evidence from Developing Countries

**Abstract**

The present study empirically assesses the role of financial sector development in determining the energy poverty of developing countries. The study utilizes a sample of 110 developing economies over a period ranging from 1990-2020. The analysis is based on the traditional econometric techniques comprising pooled OLS, fixed effects, and random effects, Driscoll and Kraay's robust standard error approach for pooled OLS, fixed effects, and random effects. To account for a possible endogeneity problem, the study also uses the system GMM model. Our empirical outcomes verify a positive role of financial sector development in alleviating energy poverty of the sample economies. The findings also provide a supportive role of economic growth, foreign direct investment, and urbanization in helping accessibility to energy services. These outcomes have strong policy implications for the developing economies.


**Created on**

8/26/2022, 11:36:12 AM

**Last Modified**

8/26/2022, 11:36:12 AM

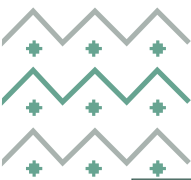
**Authors**

Muhammad Khan ( IQRA University, Islamabad (Campus) ) < khann.muhammad@gmail.com> 

**Primary Subject Area**

Energy Investment and Finance





## ***COST-BENEFIT ANALYSIS FOR PETROCHEMICAL PROJECTS: THE CASE FOR SAUDI ARABIA***

[Dongmei Chen, King Abdullah Petroleum Studies and Research Center, 966112903192, dongmei.chen@kapsarc.org]  
[Philipp Galkin, King Abdullah Petroleum Studies and Research Center, 966112903194, philipp.galkin@kapsarc.org]  
[Colin Ward, King Abdullah Petroleum Studies and Research Center, 966112903062, colin.ward@kapsarc.org]

### **Overview**

The key idea behind the cost-benefit analysis (CBA) is that for some projects the financial appraisal alone can fail to capture their gains (or costs) to a society at large. In such cases, supplementing financial indicators with those based on CBA aims to quantify in comparable currency units the project's impact on social welfare. Many countries, international organizations and development agencies have adopted CBA as one of requirements for project financing. However, the key objectives and relevant legal frameworks remain varied across nations (OECD 2015) and institutions (OBPR 2020, ADB 2009, EC 2014).

Major sectors, in which CBA is usually performed, include transportation, utilities, environment, waste management, energy, education, healthcare, ICT and R&D. In this study, we advocate for applicability of CBA for the investment decision process in the petrochemical industry, illustrated by a hypothetical project in Saudi Arabia.

Distorted market conditions, substantial government role in the sector and a broad range of external effects of petrochemical investment projects call for a framework which would: (1) account and quantify – where possible – such impacts and distortions; (2) provide an option to amend the financial KPI's of the project based on such calculations; (3) extend the project risk assessment framework accordingly. We propose such methodology based on the general CBA framework and practices established for other sectors and illustrate the proposed theoretical framework with a petrochemical investment project case study.

### **Methods**

For this study, we apply the methodology based on the general CBA framework and established best practices for other sectors highlighted in EC (2014), and tailor it to the specifics of the petrochemical industry. First, we produce financial plans based on the set of cost estimates for an ethylene plant in Saudi Arabia, Malaysia, and China under the following assumptions: the plants use the same technologies and feedstocks; the plants are the same size (1.5 Mtpa); the plants were constructed at the same time (2021); the only differences are the locations and associated construction and operation costs; all the projects target Chinese market for their output.

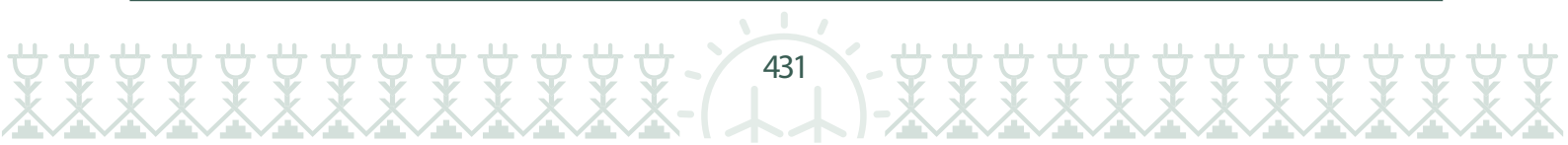
In the second phase we apply the CBA methodology to the project located in Saudi Arabia. Proposed approach covers three major areas: adjustments to the project's proforma financial plan, accounting for the project externalities, and risk assessment. For this project, major adjustments to the financial plan include the costs of inputs – natural gas and electricity – where the government-set tariffs are substituted with the market-based estimates based on domestic shadow prices. Existing CAPEX, labour costs and general overheads are assumed to reflect the market prices.

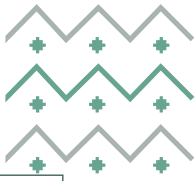
Key externalities estimated for this project cover associated pollution and climate costs, specifically, emissions of CO<sub>2</sub>, NH<sub>4</sub>, SO<sub>x</sub>, NO<sub>x</sub> and PM<sub>10</sub>. Emission volumes are calculated based on the data from similar projects, and the associated costs are taken from EC (2014) and CE Delft (2018).

For the risk management section, we apply sensitivity analysis to identify critical variables and their potential impact on the project bottom line, followed by the qualitative risk assessment, where specific risk factors, grouped into categories, are analysed according to their effects, timing, and severity.

### **Results**

Based on the financial planning results, Saudi Arabia would be the only profitable location for the project with stated assumptions. Since the revenue streams are assumed to be similar for all locations, its advantages are driven by cost competitiveness, the input costs in particular. Total project costs associated with natural gas in Saudi Arabia comprise only 25.1% of those in China and 36.8% in Malaysia; the electricity costs in Saudi Arabia amount to





60.3% and 69.9% respectively. Comparing remaining two options, Malaysia seems preferable than China due to cost advantage observed in all areas (natural gas costs in particular), except for transportation and tariffs.

The CBA adjustments significantly affect the outcome of a sample ethylene project based in Saudi Arabia, reducing its NPV by \$7.1 billion. Pollution and climate costs amount to \$5.0 billion or 9.6% of the adjusted project OPEX. Removing domestic subsidies for natural gas and electricity increases the cost of natural gas up to 51.8% of the total project OPEX, followed by electricity cost at 33.0%. The resulting outcome is still more favourable than that of the "Chinese location" financial plan, however, it would make Saudi Arabia a less attractive project location than Malaysia.

Applying CBA also helped identify additional critical risk factors. The critical variables for the sample project are ethylene price, natural gas and electricity tariffs. The latter two factors were not critical according to the pre-CBA financial plan. The impact of these factors on the project bottom line from the  $\pm 1\%$  variation in these variables is estimated at 5.5%, 2.7% and 1.7% respectively.

### Conclusions

The general principles of CBA are applicable to evaluation of investments beyond the "traditional" sectors and industries, especially if relevant markets are heavily regulated, and if a government acts as an investor or a major stakeholder of a project. In the environment where non-financial factors – including energy security, climate goals and protectionism – increasingly drive economic policy and investment, CBA provides a broader assessment of the project outcomes and can help align the interests of investors and policy makers.

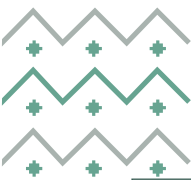
A broader scope – characteristic of CBA – also contributes to a more comprehensive project risk assessment, which is becoming increasingly relevant given the escalating trend of macroeconomic and geopolitical shocks. CBA can help identify critical risk factors that may not be visible at the financial planning stage and quantify potential impacts.

In the case of a joint international project, the perspectives of investors on certain CBA costs and externalities may not concur. The CBA practices and outcomes can also vary significantly depending on the industry and project location. The established CBA standards for specific sectors could contribute to methodological transparency and help address potential conflicts of interests.

### References

- Asian Development Bank (ADB). 2009. "Cost-Benefit Analysis for Development: A Practical Guide". <https://www.adb.org/sites/default/files/institutional-document/33788/files/cost-benefit-analysis-development.pdf>
- CE Delft. 2018. Environmental Prices Handbook 2017. Delft. May 2018. <https://cedelft.eu/publications/environmental-prices-handbook-2017/>
- European Commission (EC). 2014. "Guide to Cost-Benefit Analysis of Investment Projects". <https://op.europa.eu/en/publication-detail/-/publication/120c6fcc-3841-4596-9256-4fd709c49ae4>
- OECD. 2015. "Government at Glance 2015". [https://doi.org/10.1787/gov\\_glance-2015-en](https://doi.org/10.1787/gov_glance-2015-en)
- Office of Best Practice Regulation (OBPR) of the Australian Government. 2020. "Cost-Benefit Analysis". <https://obpr.pmc.gov.au/sites/default/files/2021-09/cost-benefit-analysis.pdf>





### **GCC Renewable Energy Development – Road to Meet 2030 Targets**

Salem Alhajraf  
CEO – EdamaConsult  
[shajraf@edamaconsult.com](mailto:shajraf@edamaconsult.com)

#### **Overview**

The current war in Europe, the rise in demand for non-Russian energy sources, the reconsideration of coal and nuclear energy sources, the ever-growing concerns surrounding climate change, the 2050 zero-emission targets, to name a few, are all contributing to the extraordinary turmoil that the global energy market is currently experiencing. The massive increase in annual Renewable Energy (RE) deployment worldwide that reach around 300,000 MW in 2021, as well as the rise of emerging clean energy technologies such as Hydrogen fuel and energy storage, have added a new dimension to the challenges confronting traditional energy markets in general and hydrocarbon-based economies in particular. Over the last five decades, GCC economies have experienced numerous energy market crises, most of which were caused by a single cause at a time, such as a war somewhere in the Middle East, fluctuating energy supply and demand, lack of new oil and gas explorations, and many others. Members of the GCC set renewable energy targets of around 28% of production by 2030 on an average. Saudi Arabia and UAE leading GCC stated with 50% and 44% targets by 2050 and 2030 respectively. Although many projects have been completed or are in various stages of development in the region, the road to achieve RE set targets is still in its early stages, with many challenges and obstacles waiting the ambitious plans to reduce reliance on hydrocarbons economy and increase non-hydrocarbon share of GDP.

#### **Methods**

Today's energy transition shifted from theory to implementation with announcement of policies, strategies, action plans, and performance measures by many developed and developing countries. Taking GCC as a case for study, this paper analyzes the strategic position of GCC economies in containing external and internal energy market forces under three RE technology mix scenarios by 2030 and beyond, the Diverse (Scenario 1), which examines a broader selection of RE mature technologies to prevent a single technology from dominating the sector. The Low-cost (Scenario 2) technology mix that ensures the lowest required investment (capital cost), resulting in the lowest LCOE. Finally, the Yield (Scenario 3) where an optimum technology mix is selected to guarantee maximum annual energy production with respect to total annual consumption of GCC.

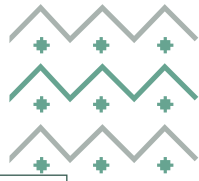
The impact of these scenarios on GCC economies are evaluated based on number of key factors such as investment size, local content and value chain, ability to attract foreign capital and impact on electricity grid stability. Other important factors, such as fuel offset and CO<sub>2</sub> emission prevention are equally achieved by the three examined scenarios thus, they are not included in the assessment.

#### **Results**

Based on the above methodology and the announced RE targets by each of the six GCC states, the analysis projected that the required RE installed capacity is approximately 84,000 MW by 2030 to 2035, starting with 3,600 MW installed in 2021 which is approximately 4% of the 2030 compound targets. Today, the UAE led GCC market with approximately 2,706 MW followed by Saudi Arabia with approximately 443 MW installed capacity. Oman and Qatar followed with 211 and 143 MW respectively. Kuwait and Bahrain have 106 MW and 12 MW of installed capacity respectively. To meet GCC RE targets, UAE is required to add 15,500 MW by 2030 while Saudi Arabia must add 58,000 MW. To meet the RE targets, the other four GCC countries, they must add a total of 8,500 MW by 2030.

Five RE technologies are selected to examine the three scenarios: Photovoltaic (PV utility scale), Photovoltaic (PV rooftop and distributed generation), Concentrated Solar Thermal Power (CSP),





Onshore Wind Energy and Others small-scale technologies such as biomass and waste to energy. Investment required by each country for each technology are identified for each of the three scenarios. PV dominating the technology use in the six GCC states due to its maturity, low LCOE and low operation and maintenance costs. Wind energy came second due to abundant resources and low production costs mainly in Saudi Arabia northeastern desert and along the Oman shoreline. Despite the high solar direct radiations in the region and the high potential production capacity of solar thermal technology, the technology share of CSP is low in the three examined scenarios due to high capital cost and operation and maintenance costs. CSP share might increase once LCOE competes with PV and Wind technologies.

The required investment per technology per country is projected based on current actual market installation costs for each of the technology mix segments. All scenarios examined shows that GCC will need to invest 100-130 B\$ over the next 10 years to achieve RE targets. Utility scale PV led the technology with about 40 B\$ followed by Wind with around 30 B\$. Due to the size of required RE deployment, Saudi Arabia projected to invest 70-90 B\$ depending on the technology mix scenario selected. The UAE came in second with approximately 20 B\$, followed by the rest of GCC countries with approximately 14 B\$ in required investment collectively.

### Conclusions

The paper concluded that for GCC to diversify national economies and sustain development growth with less reliance on the hydrocarbon revenue, an implementation of inhouse value chain of RE industry is essential to maximize the investment circulation within GCC markets. Another critical issue is the geographic distribution of RE projects across GCC close to high consumption areas such as large cities and industrial zones to avoid losses on long distance transmission lines and make a balance to decentralize power generation.

### References

1. **IEA 2022.** Renewable Energy Market Update - Outlook for 2022 and 2023. Available Online: [Renewable Energy Market Update 2022.](#)
2. **IEA 2022.** World Energy Investment 2022. Online: [World Energy Investment 2022.](#)
3. Financing clean energy transitions in emerging and developing economies. World Energy Investment 2021 Special Report in collaboration with the World Bank and the World Economic Forum. Available Online: [Financing Clean Energy Transitions in Emerging and Developing Economies.](#)
4. Ren21 2020. Renewables 2020 Global Status Report, 2020, Available Online: [https://www.ren21.net/wp-content/uploads/2019/05/gsr\\_2020\\_full\\_repor\\_en.pdf](https://www.ren21.net/wp-content/uploads/2019/05/gsr_2020_full_repor_en.pdf).
5. Towards 100% Renewable Energy: Utilities in Transition, Abu Dhabi, 2020, Available Online: [https://coalition.irena.org/-/media/Files/IRENA/Coalition-for-Action/IRENA\\_Coalition\\_utilities\\_2020.pdf](https://coalition.irena.org/-/media/Files/IRENA/Coalition-for-Action/IRENA_Coalition_utilities_2020.pdf).
6. Antigua & Barbuda Renewable Energy Roadmap, Abu Dhabi, 2021, Available Online: [https://irena.org/-/media/Files/IRENA/Agency/Publication/2021/March/IRENA\\_Antigua\\_Barbuda\\_RE\\_Roadmap\\_2021.pdf](https://irena.org/-/media/Files/IRENA/Agency/Publication/2021/March/IRENA_Antigua_Barbuda_RE_Roadmap_2021.pdf).
7. Net Zero by 2050: A Roadmap for the Global Energy Sector, 2021, Available Online: <https://www.iea.org/reports/net-zero-by-2050>.
8. **D. Bogdanov, et al.** 2021. Low-cost renewable electricity as the key driver of the global energy transition towards sustainability, Energy, vol. 227, Jul. 2021.
9. **IRENA 2021.** Renewable Capacity Highlights, Abu Dhabi, 2022, Available Online: [IRENA -RE Capacity Highlights 2021.pdf](#)
10. **O. Osman, et al.** 2020. Scaling the production of renewable ammonia: A techno-economic optimization applied in regions with high insolation, J. Cleaner Prod., vol. 271, Oct. 2020.
11. **C. Breyer, et al.** 2022. On the History and Future of 100% Renewable Energy Systems Research. Received 10 June 2022, accepted 19 July Digital Object Identifier 10.1109/ACCESS.2022.3193402. Available Online: [IEEE Xplore Full-Text PDF.](#)





## ***ESG AND ITS IMPACT ON OIL & GAS INVESTMENTS***

Julio Arboleda, IAEE 27170, +966563750525, julio.arboleda@kapsarc.org

### **Overview**

The oil and gas industry has suffered from external discreditation through pressure from climate change advocates and social issues, generating stigmas that affect the investment attractiveness, thus, discouraging investors from financing upstream projects. The investment crisis in the oil and gas sector became more evident during the COVID-19 pandemic, raising concerns that still have not been solved and that could generate a supply crisis in the near future

In addition, public pressure to implement ESG strategies in the oil & gas industry is pushing away the required investment to secure the required supply. ESG, a concept that should help companies through the energy transition, unfortunately, is not understood correctly, generating the escape of a significant amount of investment away from the industry. This presentation will help us better understand the role of ESG in the oil & gas industry and will ring the alarm about the underinvestment that the oil & gas industry is facing and its consequences.

### **Methods**

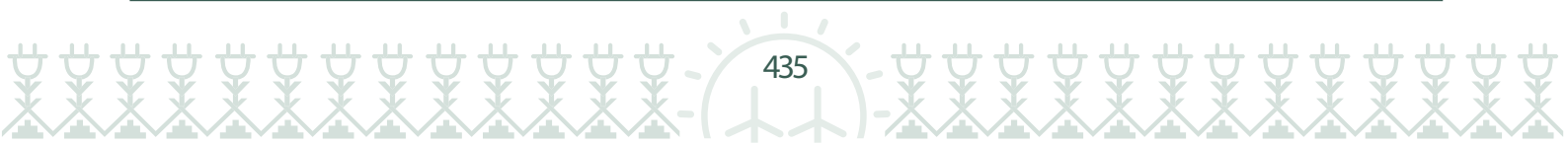
The analysis is based on data observation from different sources, resulting in investment data assessment of the oil and gas industry, and presented in the final presentation. It also includes an analysis based on the industry's available bibliography. Finally, it brings everything together to support the hypothesis that the oil and gas industry has an urgent need for investment and the impact that the misconception of the ESG concept is generating.

### **Results**

The final presentation analyses the oil and gas industry challenges that generate concerns among policymakers and investors and reduce investment attractiveness. The study suggests that the lack of proper standardized methodology for calculating ESG is generating a misconception among investors, who have focused only on the concept's environmental (E) section. Governance (G) and social (S) sections have been forgotten, resulting in a desperate race to move towards a clean image instead of working on a responsible transition that could help the world to avoid an energy supply crisis.

### **Conclusions**

- A substantial increment in investment in oil and gas is needed today to guarantee energy security from 2025 and beyond.
- A misinterpretation of the ESG concept brings investment scarcity and instability to the oil and gas industry.
- Environmental activities do not equal ESG fulfillment. The governance and social part are being forgotten.
- The intervention of activist shareholders and environmentalists has also pushed most big international oil companies (IOCs) to set net-zero targets during 2021.
- The significant pressure that climate policies have on governments, NOCs, and IOCs is evident. The private sector is the most vulnerable and will probably be the first to succumb to rapid transitions and cuts to production and exploration investment.
- Attracting and retaining human talent in the oil & gas industry is an issue that needs to be managed today.





## Closing the Investment Gap to Achieve the Paris Agreement Goals

Fatih Yilmaz, KAPSARC, 0112903059, [fatih.yilmaz@kapsarc.org](mailto:fatih.yilmaz@kapsarc.org)

Fahad Alswaina, KAPSARC, 0112903047, [fahad.swaina@kapsarc.org](mailto:fahad.swaina@kapsarc.org)

Fateh Belaid, KAPSARC, 0112903096, [fateh.belaid@kapsarc.org](mailto:fateh.belaid@kapsarc.org)

Mohamad Hejazi, KAPSARC, 0112903069, [mohamad.hejazi@kapsarc.org](mailto:mohamad.hejazi@kapsarc.org)

Mari Luomi, KAPSARC, 0112903037, [mari.luomi@kapsarc.org](mailto:mari.luomi@kapsarc.org)

Salaheddine Soummane, KAPSARC, 0112903178, [salaheddine.soummane@kapsarc.org](mailto:salaheddine.soummane@kapsarc.org)

### Overview

In this study, we assess whether global sustainable financial flows are in line with the transition investment necessities. To do this, we first identify investment gaps that are defined as the difference between the required annual investment to keep up with the global net NZE targets and the current investment flows. Our assessment of the investment gaps reveals that almost all countries must significantly accelerate their efforts, as their current investment levels lag behind the required levels. Secondly, investment gaps are particularly large for non-Annex I (developing) countries. Financing this massive scale investment needs continues to be a major challenge globally, where the size of global environmental, social, and governance (ESG) finance remains low. More importantly, despite their larger investment gaps, developing countries receive a minor share from global ESG funds, where access to conventional finance is already weak.

### Methods

Investment gaps across countries are defined as the difference between current investment flows and the annual investment required to achieve a Paris Agreement-aligned scenario. Our assessment of this investment is based on a Global Change Analysis Model (GCAM) developed by Ou et al. (2021), which focuses on the power sector. While a significant portion of the effort to reach NZE relies on the power sector as a decarbonization lever, our analysis does not capture the full transition picture. It, nevertheless, provides data appropriate for a cross-country analysis. The current investment flows are obtained from the BloombergNEF that is available on an annual basis with significant country coverage. We then compare the investment gaps with global ESG debt flows, also obtained from BloombergNEF. The debt flows include the annual issuance of green, sustainable, and sustainability-linked bonds and loan issuances.

### Results

Our results show that investment realization levels for Annex I economies are higher, relative to their required investment levels, than in the non-Annex I (developing country) group (Figure 1). Put differently, while developed countries will need 2.1 times more investment in the Paris-aligned scenario, this number is much higher for the developing nations, around 2.6. Excluding the United States (e.g., lower investment performance relative to required levels) from Annex I and China from non-Annex I groups double the investment gap between the two groups. More specifically, the gap decreases to 1.8 times the current levels for developed countries and increases to 4.8 times for developing countries.

Our analysis of financial development differences between the developed and developing world reveals similar gaps. Countries with low financial development, defined as scoring low on the IMF's Financial Development Index, also tend to experience large investment gaps. In addition to the ongoing financial development challenges, many developing economies have not yet developed the local ESG frameworks that would help them engage with a fast-changing global investment environment, where ESG is becoming the new norm for the financing of sustainable energy transitions. The current annual share of non-Annex I countries of total ESG investments is quite low, with most of these funds concentrated in European and North American countries. One may argue that with the global ESG trend in the financial markets, lesser resources will potentially be available for developing economies if they cannot timely adapt to this new norm.



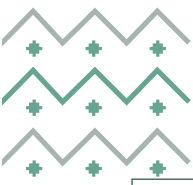
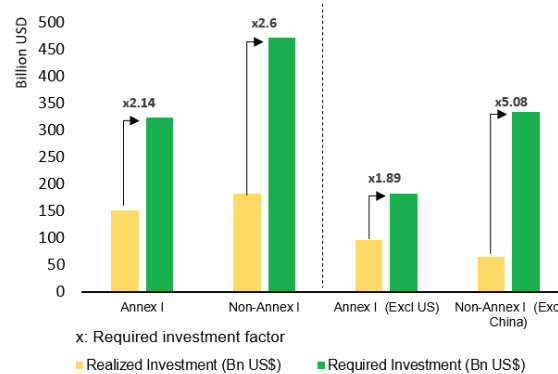


Figure 1: Sustainable energy investment gaps by country groups.



Source: Authors' calculation from Bloomberg, World Bank, and Ou et al. (2021).

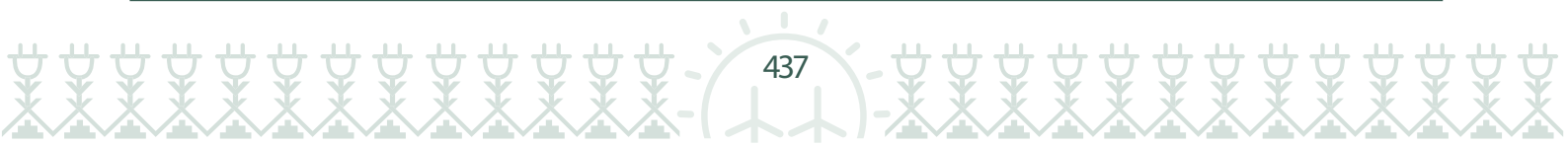
Note: Realized investment is the average sustainable energy transition investment flows into the power sector between 2019 and 2021, from Bloomberg. The required investment is the average investment flow needed to achieve the Paris Agreement-compatible scenario in the model. "x" is the additional investment needed to achieve the required level. Annex classification is based on the UNFCCC. Sustainable energy transition investment numbers in the figure include hydro, geothermal, bioenergy, solar, wind, and nuclear investments. CCUS investments are not included due to data shortages.

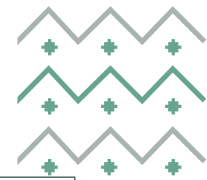
## Conclusions

Considering such bottlenecks, accelerated action and cooperation are required on many fronts to improve the financing conditions for sustainable energy transitions, especially in the case of developing economies. Firstly, globally recognized ESG guidelines have yet to be established. This has resulted in ambiguity for investors and hence, impeded scaling-up efforts. More importantly, a global ESG framework should be flexible enough conceptually to accommodate sectoral and geographic differences across the world. For instance, industry structures in many developing economies currently are much more carbon-intensive than in industrialized economies, which creates obstacles to electrification in the short to mid-run. In such cases, carbon management technologies (e.g., carbon capture, utilization, and storage, CCUS) or different clean hydrogen fuels (e.g., both green and blue hydrogen and ammonia) should be clearly and directly included in global ESG frameworks. Secondly, global cooperation on climate finance should be expanded in multiple dimensions, leveraging various tools, including increased climate finance provision and mobilization by the developed economies, knowledge sharing among countries, and more active contributions from international institutions to the process via capacity building, policy support tools, and funding.

## References

Ou et al., 2021. Can updated climate pledges limit warming well below 2°C? SCIENCE, 374, 6568, 693-695, DOI: 10.1126/science.abl8976.





***THE EFFECT OF GREENHOUSE GAS EMISSIONS AND GREEN INNOVATION ON CORPORATE INVESTORS' FINANCIAL PERFORMANCE: TOWARD NET ZERO EMISSIONS***

Fatima Shuwaikh, Léonard de Vinci Pôle Universitaire,  
 Research Center, 92916 Paris, France, [fatima.shuwaikh@devinci.fr](mailto:fatima.shuwaikh@devinci.fr)  
 Thomas Chemmanur, Boston College, Carroll School of Management  
 MA 02467, United States, [thomas.chemmanur@bc.edu](mailto:thomas.chemmanur@bc.edu)

**Overview**

This paper presents the first detailed analysis of the impact of greenhouse gas (GHG) emission reduction on corporate venture capital (CVC) investments in the US over 18 years between 2002 and 2019. The study considers the three scopes of GHG emissions by CVC firms. Additionally, patents, citations, and weighted citations are analyzed to present an in-depth discussion of the impact of green innovation by CVC firms on their financial outcomes. These findings contribute to the ongoing debate on corporations' role in reaching net-zero emissions. Due to the positive effect of corporate social responsibility (CSR) performance in building a sustainable competitive advantage (Battisti et al., 2022), we argue that there is a positive moderating effect of social and environmental performance scores on the effect of both environmental performance and green innovation on corporate investors' financial performance. Moreover, the results show the isolated and combined effects of GHG emission reduction and green innovation on the financial performance of CVC firms. The results indicate that emission reductions give firms a financial advantage over time and that corporate investors are interested in driving green innovation. Furthermore, the results investigate the mediating role of CSR on CVC firms' environmental and financial performance. The results outlined in this paper have important implications for research and practice and illustrate the importance for corporate investors of including ecological considerations in their overall business strategies to create a competitive advantage.

**Methods**

The selected sample comprises annual longitudinal data on U.S. firms between 2002-2019, based on the Thomson VentureXpert database to construct the main sample of firms that make at least one CVC investment. Financial and accounting data are collected from the Standard and Poor's Compustat database. GHG emissions data is retrieved from Refinitiv Eikon. The target period between 2002-2019 is chosen as GHG emissions data is only available on Eikon for firms starting in 2002. The final sample comprises 133 corporate investors and 2,394 observations after removing missing variables and records that do not disclose the firm's name. Green patent data is furthermore retrieved from the PATSTAT database. In this paper, three different measures of financial performance (FINPER) are introduced as dependent variables, namely Net Profit, ROE, and Tobin's Q. Environmental performance (ENVPER) is assessed by using GHG emissions, that is, total CO<sub>2</sub> and CO<sub>2</sub>-equivalent (CO<sub>2</sub>e) emissions (in tons), following the GHG protocol (Bhatia et al., 2004) As using absolute GHG emissions would entail significant tail risk, two different measures are used to assess environmental performance, being the natural logarithm of GHG emissions (lnGHG) and GHG emissions per unit of revenue, that is GHG emissions intensity (GHGrev). Following (Chemmanur et al., 2014; Shuwaikh & Dubocage, 2022), two different patent-based measures are considered to assess both the quantity and the quality of green innovation. Both green innovation variables are based on the patent application year. First, the number of green patent applications by a firm in each year (Count) is introduced to analyze innovation quantity. Second, the number of subsequent citations of these green patents (Citations) is used to measure innovation quality. Following Hall et al. (2000, 2001, 2005), the citation truncation bias is corrected by estimating the shape of the citation-lag distribution. As moderating variables, two variables measuring CSR performance are being used. Both the environmental pillar score and the social pillar score are being retrieved from the Eikon ESG database. The environmental score (ENV) reflects the CSR performance relating to environmental aspects by measuring firms' impact on living and non-living natural systems. It considers a company's performance in avoiding environmental risks and taking advantage of environmental opportunities. On the other hand, the social score (SOC) indicates the performance relating to social aspects and reflects firms' behavior towards their workforce, customers, and society. Both variables indicate scores on a scale between 0 and 100 and therefore allow directly measuring the outcomes of firms' CSR performance relating to social and environmental aspects. The set of control variables considered in this paper encompasses six distinct variables. Financial leverage (LEV), Firm size (SIZE), Asset structure (AssetStr), and independent board members (IBM) indicate the percentage of independent board members, Sustainability reporting (SusRep), and Governance score (GOV).





## Results

The paper investigates the effect of environmental performance on firm performance in year  $t+3$ ,  $t+2$  and  $t+1$ , for the reason that the impact of emission reduction costs on firm performance is time lagging (Hart and Ahuja, 1996). The strongest positive relationship is found with respect to Tobin's Q, with a one-unit increase in GHG emissions resulting in an increase of 13 percentage points in Tobin's Q, on average in year  $t+3$ . This result is statistically significant at the 1% level. This result suggests that firms with lower GHG emissions have a higher long-term financial performance. The results indicate, in year  $t+1$  scenario, a positive impact of GHG emissions intensity on Net Profit. Our results are in line with the findings of Busch and Hoffmann (2011), Ganda and Milondzo (2018), Chen & Ma (2021) and Benkraiem et al. (2022). Additionally, the results investigate the impact of corporate investors' green innovation on their financial performance. For all measures of green innovation, this paper finds a positive effect in year  $t+3$  for the financial performance in terms of Net Profit (5%), ROE (10%), and Tobin's Q (1%). This result indicates that corporate investors should have a strong financial interest in driving green innovation. Sustainability-linked innovation pays off in the short and long term. The results indicate a positive moderating effect of the environmental performance score, as a measure for CSR performance, in determining the effect of environmental performance on financial performance. These results suggest that only the environmental aspect of CSR improves the financial outcomes of reduced GHG emissions, while the social CSR aspects are not affecting this relationship (Atif et al., 2021).

## Conclusions

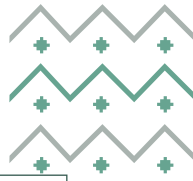
This paper examines the effect of GHG emissions and green innovation on the financial performance of corporate investors and demonstrates that both better environmental performance and more green innovation have positive effects on corporate investors' financial performance. The results outlined in this paper have important implications for research and practice. An inclusive policy should be implemented combining environmental performance targets and financial performance objectives. This reinforces the argument that firms should include emission reduction as part of their overall corporate strategy to increase profitability. As the cost of adopting carbon-reducing measures remains one of the major constraints for many firms, governments and policymakers need to provide the necessary incentives to encourage firms to reduce their carbon emissions. In the specific case of corporate investors, societal changes may act as an additional incentive, as stakeholders increasingly demand improved performance levels in domains other than purely financial results. This cultural shift will continue to encourage corporate change as society realizes the urgent need for ecological and social change. As previous studies show, CVC investments allow investors to acquire the necessary resources for sustainable competitive advantage (Battisti et al., 2022). Governments and policymakers must incentivize companies to reduce their emissions and drive green innovation while creating the necessary framework to support CVC investments.

## References

- Battisti, E., Nirino, N., Leonidou, E., & Thrassou, A. (2022). Corporate venture capital and CSR performance: An extended resource based view's perspective. *Journal of Business Research*, 139, 1058–1066. <https://doi.org/10.1016/j.jbusres.2021.10.054>
- Benkraiem, R., Shuwaikh, F., Lakhali, F., & Guizani, A. (2022). Carbon performance and firm value of the World's most sustainable companies. *Economic Modelling*, 116, 106002. <https://doi.org/10.1016/j.econmod.2022.106002>
- Busch, T., & Hoffmann, V. H. (2011). How Hot Is Your Bottom Line? Linking Carbon and Financial Performance. *Business & Society*, 50(2), 233–265. <https://doi.org/10.1177/0007650311398780>
- Chen, Y., & Ma, Y. (2021). Does green investment improve energy firm performance? *Energy Policy*, 153, 112252. <https://doi.org/10.1016/j.enpol.2021.112252>
- Gonenc, H., & Scholtens, B. (2017). Environmental and Financial Performance of Fossil Fuel Firms: A Closer Inspection of their Interaction. *Ecological Economics*, 132, 307–328. <https://doi.org/10.1016/j.ecolecon.2016.10.004>
- Iwata, H., & Okada, K. (2011). How does environmental performance affect financial performance? Evidence from Japanese manufacturing firms. *Ecological Economics*, 70(9), 1691–1700. <https://doi.org/10.1016/j.ecolecon.2011.05.010>
- Misani, N., & Pogutz, S. (2015). Unraveling the effects of environmental outcomes and processes on financial performance: A non-linear approach. *Ecological Economics*, 109, 150–160. <https://doi.org/10.1016/j.ecolecon.2014.11.010>
- Shuwaikh, F., & Dubocage, E. (2022). Access to the Corporate Investors' Complementary Resources: A Leverage for Innovation in Biotech Venture Capital-Backed Companies. *Technological Forecasting and Social Change*, 175, 121374. <https://doi.org/10.1016/j.techfore.2021.121374>
- Qian, L., Xu, X., Sun, Y., Zhou, Y., 2022. Carbon emission reduction effects of eco-industrial park policy in China. *Energy* 261, 125315. <https://doi.org/10.1016/j.energy.2022.125315>







## Quantifying the value of reduced investment risk under different green energy support policies

Peio Alcorta, Department of Economics, University of the Basque Country (UPV/EHU), E-mail: peio.alcorta@ehu.eus  
 Maria Paz Espinosa, Department of Economics, University of the Basque Country (UPV/EHU)

Cristina Pizarro-Irizar, Department of Economics, University of the Basque Country (UPV/EHU) & Basque Centre for Climate Change (BC3)

### Overview

Although there exist many support schemes to promote green energy penetration worldwide, Feed-in Tariff (FiT) schemes have become the preferred renewable energy support mechanism in many markets. The benchmark is the fixed-FiT scheme, a mechanism allowing Renewable Energy Sources for electricity (RES-e) producers to sell electricity at a guaranteed fixed price per generated MWh. FiT subsidies for renewable energy penetration have been of the foremost importance, and they may still play a role as long as they are carefully crafted. Indeed, by the end of 2020 many countries worldwide had a FiT in place as a support policy for RES-e development. Nevertheless, their main drawback is the huge cost they usually involve for the regulator, especially if they are not properly designed. This is the main reason why some countries have already abandoned the FiT system and introduced new schemes based on auctions (Ciarreta et al., 2014). In many auction systems, bids are made for a return on investment of renewable plants (i.e. Rate of Return (RoR) regulation), and the electricity generator's income is fixed according to the reasonable profitability set in the auction, regardless of the amount generated and the market price of electricity.

In this context, real option pricing techniques are an appropriate tool to analyze the RES-e investment decision process, since they allow to assess investment opportunities as a function of their volatility (Lee and Shih, 2010). In particular, Haar and Haar (2017) propose using option theory to model FiT subsidies as European put options in order to quantify the value of the risk that is transferred from the investor to the regulator. According to Haar and Haar (2017), the risk accepted by the regulator, which is ultimately transferred to the rest of the society, could be hypothetically hedged by purchasing a strip of put options (the right to sell) with strike prices equal to the FiT price.

In this paper, we argue that the risk faced by an investor in renewable energy is not only due to the price of electricity but also to the fact that the amount of electricity produced is uncertain, especially for technologies that are heavily dependent on weather conditions, such as solar and wind. For this reason, we extend the previous literature using option theory to estimate the value of the investment risk removed by a RES-e subsidy, considering both the randomness of the market price as well as that of the amount of electricity generated. We contribute a methodology for pricing energy subsidies that models jointly market prices and generation as correlated stochastic processes.

Since under FiT the price per MWh produced is guaranteed, the producer's revenues (and for the same reason the generator's costs) are subject to uncertainty in the number of units generated. On the other hand, under the RoR system, a fixed return is guaranteed, thus eliminating the risk of lower than expected revenues due to poor generation. However, it also eliminates the possibility of higher potential revenues due to higher than expected generation. Therefore, our methodology allows us to compare the value of these two important incentive systems taking into account all these considerations regarding the different risks involved and the risk-sharing under each scheme.

Finally, we present an application where we compare the performance of the FiT scheme and the RoR regulation in the Spanish electricity market, which transitioned from the former system to the latter in 2013.

### Methods

For a given renewable technology, we model both the Volume Weighted Average Price (VWAP) of electricity and the amount of generation during a given period, say a year, as stochastic processes  $S_t$  and  $X_t$  respectively. Long-term electricity prices have been modeled as Geometric Brownian Motion processes (GBM). We propose that the annual generation of RES-e technology can also be approximated as a GBM, as it seems reasonable to approximate it as a log-normally distributed variable. The risk-neutral dynamics of the problem are given by:

$$\begin{cases} dS_t = rS_t dt + \sigma_S S_t dW_t^S \\ dX_t = rX_t dt + \sigma_X X_t dW_t^X \\ dW_t^S dW_t^X = \rho dt \end{cases} \quad (1)$$

where  $W_t^S$  and  $W_t^X$  are two correlated Brownian motions with correlation parameter  $\rho$ ,  $T$  is a fixed final time,  $r$  is the risk-free rate, and  $\sigma_S$  and  $\sigma_X$  are the volatilities of each process. The fundamental theorem of asset pricing implies that in a complete market a derivative's price at any initial time  $t$  is the discounted expected value of the payoff at future maturity time  $T$  under the risk-neutral measure.

Under the FiT scheme the generator has a guaranteed minimum price  $K_{FiT}$  per generated MWh. Thus, the payoff at maturity offered by the subsidy is given by the product of the annual generation ( $X_T$ ) and the payoffs for each produced MWh  $(K - S_T)^+$ . Hence, the value of the subsidy at  $t = 0$  is given by the expectation under the risk-neutral measure:  $V_{FiT} = \mathbb{E}^Q[e^{-rT} X_T (K_{FiT} - S_T)^+ | \mathcal{F}_0]$ . On the other hand, under the RoR regulatory scheme, the generator has a guaranteed revenue ( $K_{RoR}$ ), independent of both generation and market prices. Therefore, the payoff at maturity is given by  $(K_{RoR} - S_T X_T)^+$ . Thus, the value of the RoR subsidy at  $t = 0$  is:  $V_{RoR} = \mathbb{E}^Q[e^{-rT} (K_{RoR} - S_T X_T)^+ | \mathcal{F}_0]$ .



## Results

Using stochastic calculus, we obtain the following closed-form solution for the FiT subsidy option with maturity  $T$ :

$$V_{FiT} = X_0 \left[ K_{FiT} \Phi(-d_{FiT}) - S_0 e^{(r + \sigma_S \sigma_X \rho)T} \Phi(-d_{FiT} - \sigma_S \sqrt{T}) \right] \quad (2)$$

where  $\Phi$  denotes the CDF of the standard normal distribution, and

$$d_{FiT} = \frac{\log \left( \frac{S_0}{K_{FiT}} \right) + \left( r + \sigma_S \sigma_X \rho - \frac{\sigma_S^2}{2} \right) T}{\sigma_S \sqrt{T}} \quad (3)$$

Similarly, we obtain the closed-form solution for the RoR scheme option with maturity  $T$ :

$$V_{RoR} = e^{-rT} \left[ K_{RoR} \Phi(-d_{RoR}) - Y_0 e^{\mu_Y T} \Phi(-d_{RoR} - \sigma_Y \sqrt{T}) \right] \quad (4)$$

where  $Y_0 = X_0 S_0$ ,  $\mu_Y = 2r + \sigma_S \sigma_X \rho$ , and  $\sigma_Y = \sqrt{\sigma_S^2 + \sigma_X^2 + 2\sigma_S \sigma_X \rho}$ .

$$d_{RoR} = \frac{\log \left( \frac{Y_0}{K_{RoR}} \right) + \left( \mu_Y - \frac{\sigma_Y^2}{2} \right) T}{\sigma_Y \sqrt{T}} \quad (5)$$

In addition, we perform a numerical simulation verifying that the obtained analytical solutions agree with a Monte Carlo valuation of the problem.

Finally, using the results obtained, we can design both types of incentives in such a way that their value is identical, and therefore, the regulator is indifferent between offering one or the other to the supplier. Assuming that both incentives are offered with a duration of  $T_F$  years, the total value of the subsidy will consist of a set of annual options with different maturity times over the horizon of  $T_F$  years. Therefore, both subsidies will have an identical value if:

$$\sum_{T=1}^{T_F} V_{FiT}(T, K_{FiT}) = \sum_{T=1}^{T_F} V_{RoR}(T, K_{RoR}) \quad (6)$$

For the empirical application, we use data from the Spanish market at the time when there was a transition between the two types of incentives.

## Conclusions

The risk faced by an investor in RES-e technologies that are heavily dependent on weather conditions, such as solar and wind, is not only due to the price of electricity but also to the fact that the production is uncertain. Therefore, using option theory to study the value of a subsidy considering the market price of electricity as the only source of randomness may be insufficient.

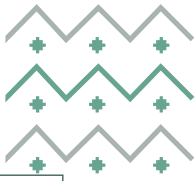
We contribute to the literature with a model to estimate the value of the investment risk eliminated by a RES-e subsidy, considering both the randomness of the market price as well as that of the amount of electricity generated. We develop a methodology that prices energy subsidies by modeling prices and generation as correlated stochastic processes. Using fundamentals of real options theory and stochastic calculus, we are able to obtain closed-form solutions to the value of FiT and RoR subsidies. Furthermore, we perform a numerical simulation to verify that the obtained solutions agree with a Monte Carlo valuation of the problem. With the developed methodology, we can directly compare two different incentive systems, the FiT, under which a price per unit sold is guaranteed, and the RoR, under which a fixed level of profitability is guaranteed.

Subsequently, we present an empirical application of the proposed theoretical model for the case of Spain, where in the last decade, the FiT system was replaced by the RoR system in an attempt to decrease regulation costs. According to our preliminary results, the value of the subsidy offered under the FiT system by the Spanish government was considerably higher than that delivered under the RoR system. This finding is consistent with the fact that the Spanish government abandoned the FiT incentive mechanism for the RoR because the former (under the incentive level offered at the time) implied excessive costs to the regulator. Our methodology could be applied to any electricity market facing, or about to face, similar challenges in terms of RES-e regulation.

Finally, our methodology allows, given the features of one of the two incentive mechanisms (prices, duration, etc.), to determine the design of the other system so that the value of both schemes, when considered as options, is identical. This *Incentive Equivalence Result* in terms of option valuation opens up the question of the optimality of incentive schemes under different criteria.

## References

- Ciarreta, A., Espinosa, M. P., & Pizarro-Irizar, C. (2014). *Switching from feed-in tariffs to a Tradable Green Certificate market*. In *The Interrelationship Between Financial and Energy Markets* (pp. 261-280). Springer, Berlin, Heidelberg.
- Haar, L. N., Haar, L. (2017). *An option analysis of the European Union renewable energy support mechanisms*. *Economics of Energy & Environmental Policy*, 6(1), 131-148.
- Lee, S.C. and Shih, L.H. (2010). *Renewable energy policy evaluation using real option model - The case of Taiwan*. *Energy Economics*, 32(1), S67-S78.



## ***TIME FREQUENCY CONNECTEDNESS BETWEEN GREEN BOND AND THE ENERGY COMMODITIES***

[Ayşe Nur Şahinler, Ankara Yıldırım Beyazıt University, +90 543 715 4725, ansahinler@ybu.edu.tr]

[Dr. Fuzuli Aliyev, ADA University, +994504651228, fmaliyev@ada.edu.az]

[Dr. Elsevar Ibadov, Baku Engineering University, UNEC Karabakh Economic Research Center, +994505234249, eibadov@beu.edu.az]

### **Overview**

Global investors are known to be very mobile in positioning their portfolios with fixed income securities and commodities to averse probable risk amid global financial, nowadays energy crises. Thus, volatility spillover and return connectedness is important for practitioners and academicians to observe the dynamics and position portfolios accordingly. This study uses daily data for the S&P Dow Jones Green Bond Index, a representative of the global green bond market, and 4 energy commodities, namely crude oil, gas oil, heating oil, and natural gas, to measure the overall connectedness and pairwise connectedness between green bonds and energy commodities. The sample period that DataStream collected is from December 2008 to September 2022. All data is in USD, and returns are determined as the difference between the logarithms of two consecutive prices. Empirical studies on the association of green bonds with the commodity market is still growing. On the eve of energy crises in Europe, this study contributes to literature focusing on connectedness between green bonds and only energy commodities.

### **Methods**

We apply the dynamic connectedness method proposed by Diebold and Yılmaz (2012) in this paper. This method generates gross and net directional spillover measures that are unaffected by the ordering of the volatility forecast error variance decompositions. This method allows us to measure the dynamics of spillovers by looking at rolling-sample total spillovers, rolling-sample directional spillovers, rolling-sample net directional spillovers, and rolling-sample net pairwise spillovers for return and volatility.

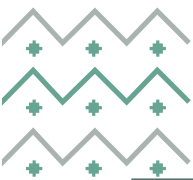
### **Results**

Findings demonstrate that the connection between green bonds and energy commodities is established via bidirectional information spillovers. The green bond market gives energy commodities less in terms of returns and volatility than it receives regardless of the period. In comparison to other energy commodities, gas oil plays a bigger role in transmitting returns and volatility to the green market. We also observe that return and volatility spillover increase dramatically during the period of crisis and vary over time. Our findings appear to support the idea that shocks have an impact on the link between the green bond market and energy commodities. Opportunities for portfolio diversification will decline when connectedness increases significantly. On the one hand, green bonds are a net receiver of spillover for the entire period; yet time spillover analysis reveals that the green bond market is a net contributor in sub-samples.

### **Conclusions**

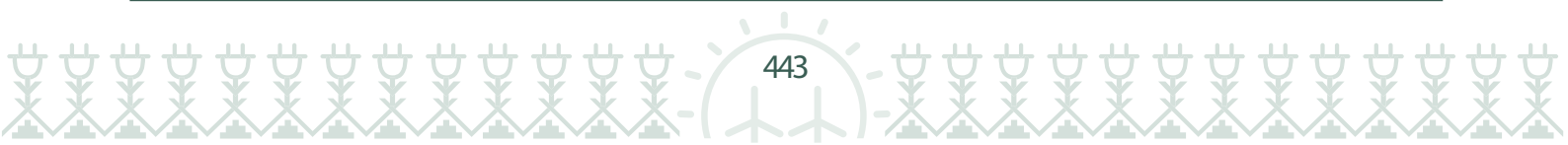
The paper studies connectedness between green bonds and energy commodities using Diebold and Yılmaz method. Our empirical findings are valuable for portfolios managers, investors as well as policymakers. The investor or manager should be aware of the connectedness and spillover directions when designing their portfolios or making decisions that includes energy commodities namely, crude oil, gas oil, heating oil, and natural gas, and green bonds. We find that the green bond market has less volatility and return impact on energy commodities than it gets from them. In the other hand, gas oil has higher returns and volatility transmission to the green market. This connectedness imply portfolio managers should diversify their portfolios with relatively less correlated assets with energy commodities. And our findings suggest that during crises periods portfolios should be repositioned considering higher spillover effect.

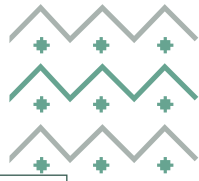




## References

- Diebold, F. X., & Yilmaz, K. (2012). Better to give than to receive: Predictive directional measurement of volatility spillovers. *International Journal of forecasting*, 28(1), 57-66.
- Naeem, M. A., Nguyen, T. T. H., Nepal, R., Ngo, Q.-T., & Taghizadeh-Hesary, F. (2021). Asymmetric relationship between green bonds and commodities: Evidence from extreme quantile approach. *Finance Research Letters*, 101983. doi:10.1016/j.frl.2021.101983
- Arif, M., Hasan, M., Alawi, S. M., & Naeem, M. A. (2021). COVID-19 and time-frequency connectedness between green and conventional financial markets. *Global Finance Journal*, 49, 100650.
- Bahloul, S., & Khemakhem, I. (2021). Dynamic return and volatility connectedness between commodities and Islamic stock market indices. *Resources Policy*, 71, 101993.
- Diebold, F. X., Liu, L., & Yilmaz, K. (2017). *Commodity connectedness* (No. w23685). National Bureau of Economic Research.
- Elsayed, A. H., Nasreen, S., & Tiwari, A. K. (2020). Time-varying co-movements between energy market and global financial markets: Implication for portfolio diversification and hedging strategies. *Energy Economics*, 90, 104847.
- Karim, S., & Naeem, M. A. (2022). Do global factors drive the interconnectedness among green, Islamic and conventional financial markets?. *International Journal of Managerial Finance*.





## TOWARDS DEVELOPING A GREEN HYDROGEN POTENTIAL MAP FOR THE KINGDOM OF SAUDI ARABIA

[Mohammed Alquhays, King Fahd University of Petroleum and Minerals, +966567755918, Mohammed.alquhays@gmail.com]

[Abdulaziz Almohammadi, King Fahd University of Petroleum and Minerals, +966543968222, abdulaziz098123@gmail.com]

[Ali T. Al-Awami, King Fahd University of Petroleum and Minerals, +966549331381, aliawami@kfupm.edu.sa]

### Overview

The objective of this paper is to develop a green hydrogen potential map for the Kingdom of Saudi Arabia. Recognizing the importance of resource assessment maps for encouraging investment at lower risk, similar maps exist for assessing the wind and solar photovoltaic potential in the Kingdom. However, a hydrogen potential map is yet to be developed. The hydrogen potential map will help the government of Saudi Arabia to develop and implement an effective policy for the utilization of renewable resources. Also, this will help them to explore the use of these renewables as a key enabler in the development of sustainable electrical energy, market opportunities, and continuous economic growth. This green hydrogen can be an alternative source to conventional sources because it is clean and environment friendly, thus may help mitigate GHG emissions

### Methods

This paper is based on a case study to produce hydrogen by the means of water electrolysis powered by 4 gigawatts of renewable resources, which are solar PV and wind energy. The results are based on comprehensive data collection along with real cost information. The study was conducted using a standard discounted cash flow rate of return methodology on different scenarios to obtain an optimum solution for the Levelized Cost of Hydrogen (LCOH) for different regions in the Kingdom. The cost calculation is based on a wide variety of inputs that characterize financial assumptions as well as capital, operating, maintenance, and replacement costs. The study also includes the cost of desalinated water used in the electrolysis process. Moreover, A sensitivity analysis has been conducted to investigate how the PV capital cost forecast for the year 2025 will affect the choice of an energy source. The equation used to calculate the Levelized Cost of Hydrogen (LCOH) in (\$/kg), is the total lifetime cost of the project divided by the total lifetime of hydrogen produced, and it is calculated as follows :

$$LCOH = \frac{CAPEX + \sum_{t=1}^N \frac{OPEX_t + REP_t}{(1+d)^t}}{\sum_{t=1}^N M_{H_2} \times \frac{(1-SRD)^t}{(1+d)^t}}$$

### Results

NEOM was chosen as a case study to be the location for the economic analysis of a system, which includes 4 GW of renewable resources, PV, and Wind. These resources are supplying a 4 GW electrolyzer plant. The economic analysis was performed from the investor's and entrepreneur's perspective to see whether it is profitable to invest in a new project that uses renewable sources to sell hydrogen as a feedstock. Desalinated water is an important part of producing hydrogen; thus, the model takes into account the levelized cost of water (LCOW) to calculate the LCOH. After trying multiple scenarios using the metrological data of solar and wind obtained from the European Commission data. it was found that the LCOH of 2.70 \$/kg. In addition, 4 GW size is considered to be an optimal size, since how matter the size is increased, the LCOH is only limited to a decrease of 2.3%. The Hydrogen Model was expanded to include a financial analysis of different regions in the Kingdom. In order to calculate the LCOH for the other regions, different values of levelized cost of water were taking into consideration from Saudi Water Partnership Company for the selected regions. Furthermore, to make the analysis more realistic, the cost of pumping desalinated water to the non-coastal region was also considered. then the LCOH was calculated for all the regions and a graphical representation of LCOH was produced as seen in below figure. We can see that NEOM has the lowest LCOH of 2.70 \$/kg while Arar has the highest of 5.85 \$/kg.



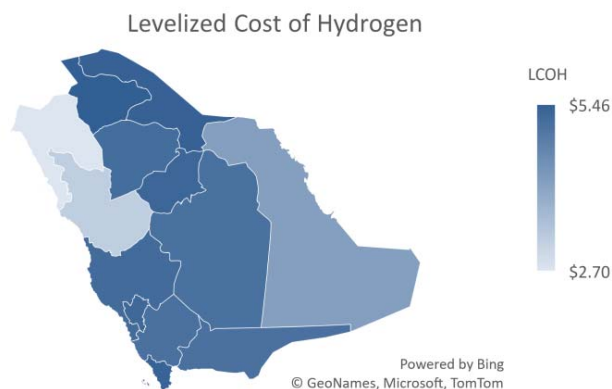


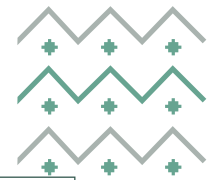
Figure 1. LCOH Potential Map

## Conclusions

In this study, an economic analysis has been performed based on LCOH to evaluate the potential of renewable-powered hydrogen production in the Kingdom. The study is to produce hydrogen by the means of water electrolysis powered by 4 gigawatts of renewable resources, which are solar PV and wind energy. NEOM was considered as a case study to build the Hydrogen Model, and later this model was applied to the Kingdom's regions. The desalinated water cost and pumping cost have been also taken into consideration in the calculation of LCOH. The LCOH results of the thirteen regions show that NEOM is the most optimal choice with an LCOH of 2.70 \$/kg. A consideration that could be drawn from this study is that 4 GW is an optimal size to supply the electrolyzer with energy since a lower size will increase the LCOH.

## References

- [1] H. Alatawi and A. Darandary, "The Saudi Move into Hydrogen: A Paradigm Shift," KAPSARC, Dec. 2020.
- [2] S. Touili, A. Alami Merrouni, Y. El Hassouani, A.-illah Amrani, and S. Rachidi, "Analysis of the yield and production cost of large-scale electrolytic hydrogen from different solar technologies and under several Moroccan climate zones," *International Journal of Hydrogen Energy*, vol. 45, no. 51, pp. 26785–26799, 2020.
- [3] M. Mohsin, A. K. Rasheed, and R. Saidur, "Economic viability and production capacity of wind generated renewable hydrogen," *International Journal of Hydrogen Energy*, vol. 43, no. 5, pp. 2621–2630, 2018.
- [4] S. Rahmouni, N. Settou, B. Negrou, and A. Gouareh, "GIS-based method for future prospect of hydrogen demand in the Algerian road transport sector," *International Journal of Hydrogen Energy*, vol. 41, no. 4, pp. 2128–2143, 2016.
- [5] A. Nicita, G. Maggio, A. P. F. Andaloro, and G. Squadrito, "Green hydrogen as feedstock: Financial analysis of a photovoltaic-powered electrolysis plant," *International Journal of Hydrogen Energy*, vol. 45, no. 20, pp. 11395–11408, 2020.
- [6] L. Idoko, O. Anaya-Lara, and A. McDonald, "Enhancing pv modules efficiency and power output using multi-concept cooling technique," *Energy Reports*, vol. 4, pp. 357–369, Nov. 2018.
- [7] Y. Zhang, Q. S. Hua, L. Sun, and Q. Liu, "Life cycle optimization of renewable energy systems configuration with hybrid battery/hydrogen storage: A comparative study," *Journal of Energy Storage*, vol. 30, p. 101470, Aug. 2020.
- [8] National Academies Press, "The Hydrogen Economy: Opportunities, Costs, Barriers, and R&D Needs," National Academies Press: OpenBook, 2004. [Online]. Available: <https://www.nap.edu/read/10922/chapter/21>.
- [9] thyssenkrupp, "Hydrogen from large-scale electrolysis," thyssenkrupp, Mar-2019. [Online]. Available: [https://ucpcdn.thyssenkrupp.com/\\_legacy/UCPthyssenkruppBAISUhdChlorineEngineers/assets.files/products/water\\_electrolysis/tk\\_19\\_0820\\_hydrogen\\_broschuere\\_2019\\_03.pdf](https://ucpcdn.thyssenkrupp.com/_legacy/UCPthyssenkruppBAISUhdChlorineEngineers/assets.files/products/water_electrolysis/tk_19_0820_hydrogen_broschuere_2019_03.pdf).
- [10] S. G. Simoes, J. Catarino, A. Picado, T. F. Lopes, S. di Bernardino, F. Amorim, F. Gírio, C. M. Rangel, and T. Ponce de Leão, "Water availability and water usage solutions for electrolysis in hydrogen production," *Journal of Cleaner Production*, vol. 315, p. 128124, Jun. 2021.
- [11] Saudi Electricity Company, "Tariffs and Connection Fees," Saudi Electricity Company, 12-Dec-2017. [Online]. Available: <https://www.se.com.sa/en-us/customers/Pages/TariffRates.aspx>.
- [12] D. Feldman, V. Ramasamy, R. Fu, A. Ramdas, J. Desai, and R. Margolis, "U.S. solar photovoltaic system and energy storage Cost Benchmark: Q1 2020," National Renewable Energy Laboratory, Jan. 2021.
- [13] G. Li and J. Zhi, "Analysis of wind power characteristics," *Large-Scale Wind Power Grid Integration*, pp. 19–51, 2016.
- [14] T. Stehly and P. Beiter, "2018 cost of wind Energy Review," National Renewable Energy Laboratory, Dec. 2019.
- [15] H. Rezk, N. Kanagaraj, and M. Al-Dhaifallah, "Design and Sensitivity Analysis of Hybrid Photovoltaic-Fuel-Cell-Battery System to Supply a Small Community at Saudi NEOM City," *Sustainability*, vol. 12, no. 8, p. 3341, 2020.
- [16] Iea, "Global average levelised cost of hydrogen production by energy source and technology, 2019 and 2050 – Charts – Data & Statistics," IEA, 23-Sep-2020. [Online]. Available: <https://www.iea.org/data-and-statistics/charts/global-average-levelised-cost-of-hydrogen-production-by-energy-source-and-technology-2019-and-2050>.
- [17] Saudi Press Agency, "NEOM announces construction of first desalination plant with solar dome technology the OFFICIAL Saudi press agency," Saudi Press Agency. [Online]. Available: <https://www.spa.gov.sa/viewfullstory.php?lang=en&newsid=2028374>. [Accessed: 26-Jul-2021].
- [18] European Commission, "JRC photovoltaic geographical information System (PVGIS)," European Commission, 11-Jan-2016. [Online]. Available: [https://re.jrc.ec.europa.eu/pvg\\_tools/en/tools.html](https://re.jrc.ec.europa.eu/pvg_tools/en/tools.html).
- [19] M. Taylor, P. Ralon, and A. Ilas, "The Power to Change: Solar and Wind Cost Reduction Potential to 2025," International Renewable Energy Agency, Jun-2016. [Online]. Available: <https://www.irena.org/publications/2016/Jun/The-Power-to-Change-Solar-and-Wind-Cost-Reduction-Potential-to-2025>.



**[THE COST-EFFECTIVENESS OF PHYSICAL VERSUS FINANCIAL RISK MITIGATION FOR HYDROPOWER SUPPLIERS]**

[Rui Shan, University of North Carolina at Chapel Hill, 9193084035, rui.shan@unc.edu]

[Rosa I. Cuppari, University of North Carolina at Chapel Hill]

**Overview**

Climate change imposes considerable risks in the electricity sector (Yalew et al., 2020). Higher temperature reduce the efficiency of thermal power plants and batteries (Jaguemont et al., 2014), and in many cases simultaneously increases electricity demand (Apadula et al., 2012). Both extremely high and low precipitation limit the power generation of hydropower plants (van Vliet et al., 2016). Other renewable energy sources, like solar and wind, are also affected by extreme weather events and climate change (Kozarcanin et al., 2019). Plants operators have adopted various financial instruments to hedge these risks, including temperature based derivative contracts. Previous analyses further show that insurance linked to weather-based index can indeed mitigate the risk of negative net revenues, and in particular extreme losses, for hydropower producers (Hamilton et al., 2020; Meyer et al., 2017). Such index-based financial instruments offset lost revenues from decreased electricity generation and increased costs as generators purchase electricity on the wholesale market to meet their fixed power contracts. The same functions might also be achieved with a large energy storage system that can offset lost generation with stored electricity. A key factor in considering which strategy to pursue is thus the cost of each tool. In this study, we will compare the performance of an energy storage system to that of an index-based financial instrument in terms of financial risk management. We establish a benchmark financial instrument which can successfully reduce a hydropower supplier's financial risk and then design an energy storage system that share similar cost. We then compare the performance of both options and discuss the implications of changing technology and costs thereof. Results can inform utilities' hedging strategies for hydrometeorological risk under an uncertain climate and increasingly volatile weather conditions.

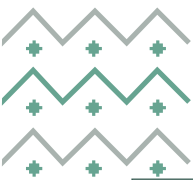
**Methods**

We choose the Bonneville Power Administration (BPA), the federal entity which manages the 31 federal dams in the US Pacific Northwest (PNW) as our case study. The BPA largely provides electricity to regional customers, which have long-term, fixed price contracts, but will sell surplus electricity into either the Mid-Columbia market, which spans the PNW, or the California Independent System Operator (CAISO), which serves California. In cases when there is a shortfall of hydropower, BPA purchases compensatory electricity from these markets. The Administration's vulnerability and exposure to hydrometeorological risk have made it the subject of scrutiny by credit ratings' agencies (e.g., Moody's, S&P, Fitch). A failure to manage its financial risk can lead to a credit downgrade, which can increase BPA's cost of borrowing. Research suggests that BPA's existing financial instruments leave it exposed to substantial uncovered losses (Denaro et al., 2022). That said, financial instruments have been proposed as a means to mitigate BPA's financial risk beyond its current capacity (Cuppari et al., 2021; Hamilton et al., 2020).

To compare the cost-effectiveness of an energy storage system versus a financial instrument, we must first establish BPA's baseline financial risk and the distribution of possible hydrometeorological conditions, including extremes. To do so, we utilize the combination of CAPOW, the California and West Coast Power System model (Su et al., 2020) and a financial model of BPA (Denaro et al., 2022). The CAPOW model is used to generate 1200 synthetic years of relevant hydrometeorological conditions across the west coast power system and corresponding electricity demand, generation, and prices, which is paired with the BPA model to calculate BPA's annual net revenues. This information is used to mimic the contract for differences financial instrument as in (Cuppari et al., 2021)

The annualized capital cost of the energy storage is assumed to be the same as the average annual cost paid for the instrument, including both the premium and negative payment based on the contract. The energy rating of the storage system is set as the maximum electricity that can be purchased given a positive payout received from the contract for a day. The operational profile is simplified to continuous charge at maximum power for a fixed duration during periods in which electricity prices are lower than a price threshold and continuous discharge when prices are higher than another threshold. The optimization model will minimize the total operation cost of the hydropower fleet plus storage by changing the threshold, power capacity and the fixed discharging/charging duration across the first 300 years of our synthetic dataset. Once determined, the storage system and corresponding operation profile will be

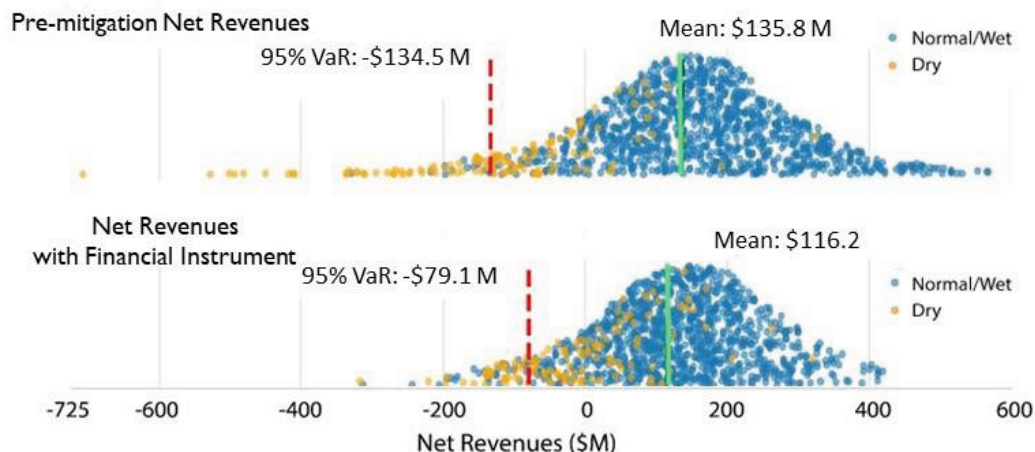




applied on the remaining 900 years of synthetic data, and the annual net revenues of the system with and without the storage system versus the financial instrument are calculated.

## Results

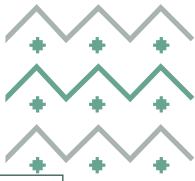
The net revenue distribution of BPA with and without financial instrument are shown below. The net revenue distribution with energy storage will be provided before the time of conference.



## References

- Apadula, F., Bassini, A., Elli, A., & Scapin, S. (2012). Relationships between meteorological variables and monthly electricity demand. *Applied Energy*, 98, 346–356. <https://doi.org/10.1016/J.APENERGY.2012.03.053>
- Cuppari, R. I., Denaro, S., Su, Y., Kern, J., & Characklis, G. (2021). New financial instruments for managing hydrometeorological risk for hydropower producers. *AGUFM, 2021*, NH14B-02. <https://ui.adsabs.harvard.edu/abs/2021AGUFMNH14B..02C/abstract>
- Denaro, S., Cuppari, R. I., Kern, J. D., Su, Y., & Characklis, G. W. (2022). Assessing the Bonneville Power Administration's Financial Vulnerability to Hydrologic Variability. *Journal of Water Resources Planning and Management*, 148(10), 05022006. [https://doi.org/10.1061/\(ASCE\)WR.1943-5452.0001590](https://doi.org/10.1061/(ASCE)WR.1943-5452.0001590)
- Hamilton, A. L., Characklis, G. W., & Reed, P. M. (2020). Managing Financial Risk Trade-Offs for Hydropower Generation Using Snowpack-Based Index Contracts. *Water Resources Research*, 56(10), e2020WR027212. <https://doi.org/10.1029/2020WR027212>
- Jaguemont, J., Boulon, L., Dubé, Y., & Poudrier, D. (2014). Low temperature discharge cycle tests for a lithium ion cell. *2014 IEEE Vehicle Power and Propulsion Conference, VPPC 2014*. <https://doi.org/10.1109/VPPC.2014.7007097>
- Kozarcenin, S., Liu, H., & Andresen, G. B. (2019). 21st Century Climate Change Impacts on Key Properties of a Large-Scale Renewable-Based Electricity System. *Joule*, 3(4), 992–1005. <https://doi.org/10.1016/J.JOULE.2019.02.001>
- Meyer, E. S., Characklis, G. W., & Brown, C. (2017). Evaluating financial risk management strategies under climate change for hydropower producers on the Great Lakes. *Water Resources Research*, 53(3), 2114–2132. <https://doi.org/10.1002/2016WR019889>
- Su, Y., Kern, J. D., Denaro, S., Hill, J., Reed, P., Sun, Y., Cohen, J., & Characklis, G. W. (2020). An open source model for quantifying risks in bulk electric power systems from spatially and temporally correlated hydrometeorological processes. *Environmental Modelling & Software*, 126, 104667. <https://doi.org/10.1016/J.ENVSOFT.2020.104667>
- van Vliet, M. T. H., Wiberg, D., Leduc, S., & Riahi, K. (2016). Power-generation system vulnerability and adaptation to changes in climate and water resources. *Nature Climate Change* 2016 6:4, 6(4), 375–380. <https://doi.org/10.1038/nclimate2903>
- Yalew, S. G., van Vliet, M. T. H., Gernaat, D. E. H. J., Ludwig, F., Miara, A., Park, C., Byers, E., de Cian, E., Piontek, F., Iyer, G., Mouratiadou, I., Glynn, J., Hejazi, M., Dessens, O., Rochedo, P., Pietzcker, R., Schaeffer, R., Fujimori, S., Dasgupta, S., ... van Vuuren, D. P. (2020). Impacts of climate change on energy systems in global and regional scenarios. *Nature Energy* 2020 5:10, 5(10), 794–802. <https://doi.org/10.1038/s41560-020-0664-z>





## *Corporate Disclosure and Green Finance Market: A Legal Perspective*

Wejdan Asiri, The General Authority for Survey and Geospatial Information, 00966542498990, asiriwejdan94@gmail.com

### **Overview**

Finance is an essential key in the move towards a climate-neutral. The 2015 Paris Agreement on climate change - the first international legally binding treaty on climate change - calls for the mobilisation of private sector financing to support the needed investments in green technologies and infrastructure that will be necessary to realise its carbon emissions goals. Within this context, a critical issue that must be kept in mind when considering the ways in which climate change could be tackled is the financial gap that an economy faces. The financial gap is a direct consequence of the significant amount of capital and investments needed in order to achieve net-zero greenhouse gas emissions., as it has been said that government funds might be insufficient to cover these significant investments. Therefore, green financial sources, specifically from the private sector, will be crucial in closing this financial gap.

As a means of addressing the financial gap issue, the introduction of Corporate sustainable financial tools, such as corporate green bonds, was necessary to enable investments on behalf of the private sector. Indeed, the issuance of corporate green bonds especially has been estimated to supply up to 84% of the private, third-party capital required to finance the development needed to transition towards a Net-Zero Economy. Green bonds were firstly introduced in 2007, however, the entrance of corporations into the green bonds market was the turning point in its growth. Ever since the green bond market has continued to grow significantly, it is the corporate green bonds that constitute the biggest share of the current green bonds market and accounted for 36% of the total issuance of green bonds in the market in 2015.

On the other hand, the securities market is already described as complex, thus, growing participation in the corporate green financial market has further resulted in disclosure becoming a pressing policy-makers concern. In that, labelling financial products as green seem to raise more funds and give certain privileges to corporations due to the strong investor demand. This has been considered from the experience of the first issuers of green bonds who noticed that these bonds were oversubscribed as opposed to conventional bonds. Reasoning to why, issuing and investing in corporate green products contributes to strengthening relationships between corporations, investors, debt providers, and local authorities. Accordingly, there is a likelihood that these financial tools will be misused to serve the interests of corporations or investors, in which disclosure plays a key role to enhance the integrity of the market.

Corporate disclosure is naturally incorporated in the process of issuing green financial instruments, however, applying the regular disclosure techniques is not enough to enhance the integrity of the market nor to make a sustainable green market in the long run. Accordingly, a specified set of disclosure obligations are being adopted by new policies, starting with the Green Bond Principles (GBPs), published by the International Capital Market Association (ICMA), which is a step towards a common issuance policy that encourages transparency and disclosure procedures. Moreover, the European Green Bond Standard (EUGBS), was announced by the European Commission as a part of its Green Deal investment plan for 2020.

### **Methods**

The paper employs a doctrinal approach to analyse regulatory initiatives on green financial instruments.

### **Results**

Indeed, disclosure obligations under the current regulations seem to lack two core elements: First, the correct scope of disclosed information. In the absence of an international consensus on specific characteristics of green projects, or even a definition of what exactly green instruments mean, irrelevant or misleading information will be disclosed. In that sense, applying disclosure while leaving it to companies to define what green means or, more precisely, what type of projects fall under the category of green, will affect the integrity along with the liquidity of the market.





Secondly, while the disclosure is naturally incorporated in the issuance of corporate green financial tools, such a mandatory form of disclosure is imperative at this stage. However, mandatory disclosure needs to include non-monetary information on the funded projects.

## Conclusions

To conclude, this paper critically discussed the type and extent of disclosure applied by regulations in the process of issuing corporate green financial tools. It could be suggested that further examination must be carried out on the use of these tools to re-fund green projects; it could be understood that using these tools to refinance such projects without clear or strict conditions could severely heighten concerns surrounding greenwashing. Finally, the concept of a corporate green market seems to serve the common good. However, are corporations actually that eager to serve the interests of society?

## References

Bishop N, 'Green Bond Governance and the Paris Agreement' [2018] 27 N.Y.U.  
Environmental Law Journal

Hamilton L, 'Canary in the Coal Mine: Can the Campaign for Mandatory Climate Risk Disclosure  
Withstand the Municipal Bond Market's Resistance to Regulatory Reform' [2010] 36 William Mitchell  
Law Review

Talbot K, 'What Does "Green" Really Mean?: How Increased Transparency and Standardization Can  
Grow the Green Bond Market' [2017] XXVIII Villanova Environmental Law Journal

Sustainability-Linked Bond Principles: Voluntary Process Guidelines (2020)

Vanguard Commentary, 'Clear Perspectives on Bond Market Liquidity' (2016)

Institute for Climate Economics, Beyond Transparency: Unlocking the Full Potential of Green  
Bonds (2016)

Friends of the Irish Environment CLG v The Government of Ireland & Ors [2019] IEHC 747 (The High  
Court)

O'Donnell v Commonwealth & Ors [2020] VID 482 (Federal Court of Australia)

State v Urgenda [2020] 19 00135 (Supreme Court of the Netherlands).







## ***ATTRACTING INVESTMENTS TO THE PETROLEUM INDUSTRY BY USING DISTRIBUTED LEDGER TECHNOLOGY***

Khaled Omar Hantoush, University of Dundee CEPMLP, [k.o.s.hantosh@dundee.ac.uk](mailto:k.o.s.hantosh@dundee.ac.uk), +96567725228  
Sayed Mehdi Alizadeh, Australian university of Kuwait, , [s.alizadeh@au.edu.kw](mailto:s.alizadeh@au.edu.kw) +96565079664  
Mohammed Saleh Al Ali Kuwait institute for scientific research +96599934366

### **Overview**

The investment in E&P has witnessed a severe decline in the last decade. This has caused a decrease in hydrocarbon discoveries in non-OPEC countries, the reserve replacement ratio is also declining for oil majors. The lack of investment is mainly due to the price volatility, which leads IOCs, hedge funds, and banks to evaluate the CAPEX invested in the industry. Democratizing investments can surge liquidity in the Petroleum industry, should retail investors gain access to specific Petroleum licenses instead of investing in IOC shares; the pace of funding and risk tolerance will aid in providing the investments needed to keep up with the global Petroleum demand. Security tokens using distributed ledger technology can provide the technical structure for this funding in addition to creating a secondary market that can create a second revenue stream for the token issuer. The tokenization of assets still demands further legislation.

### **Methods**

By using a Petroleum financial model designed on a Production sharing agreement "PSA" format. No investment will be made on the government's behalf, so in all three scenarios funding will come from either the IOC (Operator), institutional investors, or STO investors. No royalties or signature bonuses are imposed on the IOC, in addition, the IOC is entitled to cost recovery based on a DROP sliding scale. The IOC is provided a maximum of 10% profit oil also based on DROP which is subjected to a consolidated 15 % CIT. By using the model, three NPVIOC will be provided based on different partnership scenarios with traditional and Security token investors to assess the financial effectiveness of DDR on the fiscal regime's attractiveness

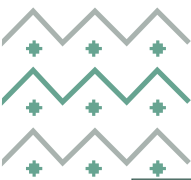
### **Results**

Based on the financial model, the IOC would achieve the highest NPVIOC under the third scenario, the elimination of any institutional participation would maximize the NPVIOC due to the ownership transfer from the token holders after the smart contract period expires. A clear influence on the GT (government takes) is also present, as discussed earlier; IOC considers the GT before making a bid for the License, the higher the GT the less attractive the investment becomes for the IOC. By adopting the split applied in scenarios one and three; the GT decreased in scenario 3 (0.73) from (0.84) in scenario 1 where no participation is made from the retail investor.

### **Conclusions**

Since the technical infrastructure is readily available; DLT can be utilized to attract investment to the Petroleum industry at a time its most needed. In principle and according to the SEC security tokens can be issued as securities and be sold to the US retail investors according to the Howey test that is currently followed, DLT allows attracting investment to Petroleum licensing rounds less expensively and effortlessly.





## **HEATING IN GERMAN CITY QUARTERS: HOW DOES THE REGULATORY FRAMEWORK INFLUENCE INVESTMENTS IN RENEWABLE TECHNOLOGIES?**

Frieder Borggreffe, Chair for Energy System Economics, RWTH Aachen University, [Frieder.Borggreffe@eonerc.rwth-aachen.de](mailto:Frieder.Borggreffe@eonerc.rwth-aachen.de)

Marius Tillmanns, Chair for Energy System Economics, RWTH Aachen University, [Marius.Tillmanns@eonerc.rwth-aachen.de](mailto:Marius.Tillmanns@eonerc.rwth-aachen.de)

Max Hoffmann, RWTH Aachen University, [Maximilian.Hoffmann@rwth-aachen.de](mailto:Maximilian.Hoffmann@rwth-aachen.de)

Chuen-Fung Tang, Chair for Energy System Economics, RWTH Aachen University, [Chuen-Fung.Tang@eonerc.rwth-aachen.de](mailto:Chuen-Fung.Tang@eonerc.rwth-aachen.de)

Lars Nolting, Chair for Energy System Economics, RWTH Aachen University and TenneT GmbH, [LNolting@eonerc.rwth-aachen.de](mailto:LNolting@eonerc.rwth-aachen.de)

Prof. Aaron Praktiknjo, E.ON Energy Research Center, RWTH Aachen University, [APraktiknjo@eonerc.rwth-aachen.de](mailto:APraktiknjo@eonerc.rwth-aachen.de)

### **Overview**

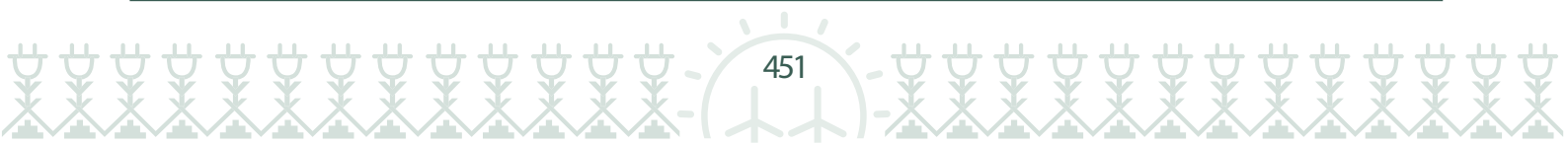
The decarbonization of the building sector is a central task for archiving the ambitious national climate targets in Germany: The building sector is responsible for 40 % of greenhouse gas (GHG) emissions. While the electricity sector has more than 50% renewable energies, the heating sector is significantly lacking behind with a share of only 15% of renewables and thus a large share of fossil fuels. Defossilization and reducing dependence on energy imports also play a major role in Germany's energy transition – amplified in the last years by high energy prices and high uncertainty about future resource availability. The building sector thus requires the transition towards local and renewable energy systems. Next generation 5th Generation District Heating and Cooling Network (5GDHC) might provide a promising pathway to include more renewables: Compared to installing renewable heating systems for every household it allows to use economies of scale and facilitates to balance different loads between households.

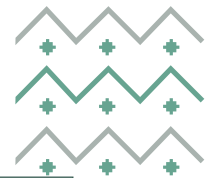
In this contribution we want to analyse:

- Which technology will choose consumers and energy companies under the given regulatory framework (investor and end-customer perspective)?
- How does the regulatory framework influence investment, share of renewable and profitability of individual technologies?
- Are there sufficient incentives to invest in innovative low temperature heating and cooling networks (5GDHC) with high shares of renewable energies? How can economic barriers caused by the regulatory framework be reduced?

### **References**

Delorme, R., Schaadt, S., Tillmanns, M., Borggreffe, F. Nolting, L. and Praktiknjo A. (2022): "The German funding jungle slows down the heat transition in the building sector", (in German: Der deutsche Förderdschungel bremst die Wärme-wende im Gebäudesektor) published in e.t. - Energiewirtschaftliche Tagesfragen, October 2022





## USE OF TRANSFER PRICES FOR INTRA-COMPANY TRANSACTIONS

Dr. Thorsten Fischer, Saudi Arabian Oil Company (Saudi Aramco)<sup>1</sup>, +966(0)13 873-1166, [thorsten.fischer@aramco.com](mailto:thorsten.fischer@aramco.com)

### Overview

Integrated oil and gas companies face issues when calculating transfer prices for intra-company transactions. The general approach is to base the transfer price on an arm's length transaction. The choice of transfer pricing method has to meet a number of competing objectives, such as optimizing the tax burden, aligning incentives between different parts of the business, and generating accurate segment reports.

If tax optimization were the only objective the solution would be straightforward. Profit should be allocated to the lower-taxed activities as much as the tax authorities will allow. Evidence will then be gathered from comparable arm's length transaction to justify the choice of the method that results in the lowest tax bill.

In principle nothing forces the integrated oil and gas company to use the same methodology for all purposes. In practice, however, the tax authorities will look with suspicion at any significant discrepancy between the financial accounts and the returns prepared for the taxman. Thus, a unified approach is generally preferred.

Not only does such a unified approach reduce complexity and eliminate duplication, it may also avoid establishing an unfortunate precedent whereby whatever method has been chosen ad hoc to minimize the tax liability of the day will commit the company to using the same method in the future, even as business conditions and the structure of the business change, and other methods would have resulted in a lower tax liability. Much better then to adopt a robust methodology that can be defended on conceptual grounds and is equally well suited to decision making and financial reporting as is it to minimizing tax liabilities.

### Methods

This paper reviews and evaluates the five methods accepted by the Kingdom's transfer pricing bylaws, which in turn rely on the OECD guidelines. Summarized under traditional transaction methods we find Comparable Uncontrolled Price (CUP), Resale Price (RP) and Cost Plus (C+). Separately, there are the transactional profit methods, including Transactional Net Margin (TNN) and Profit Split (PS).

Despite the focus of the OECD guidelines on tax, the arm's length principle is extremely powerful and as we have seen can also be used for management purposes. The arm's length principle aims to ascertain the price of a transaction that would prevail between independent companies. Such a price, if freely and voluntarily agreed by these companies, will mimic the outcome of a market transaction and therefore has some of the attending benefits. In particular both parties to the transaction must be assumed to be better off, and the mutual gains from the transaction fairly distributed.

It is convenient to interpret the transfer pricing methods as either yielding economic measures or accounting measures. The methods summarized under traditional transaction methods fall into the former category, while the transactional profit methods fall into the latter. The evaluation will proceed along these lines.

### Results

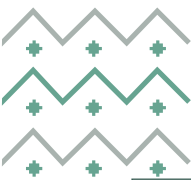
Transfer pricing methods that yield economic measures are strictly preferred to those relying on accounting metrics. Franklin M. Fisher and John J McGowan put it most succinctly in their seminal article:

*The appropriate return metric for investment evaluation is the economic rate of return. In contrast, accounting rates of return are not suitable for the analysis of future investments.*

*It is economic rates of return that are equalized within industries in long-run industry competitive equilibrium and, after adjusting for risk, are equalized everywhere in a competitive economy in long-run equilibrium. Likewise, it is an economic rate of return above the cost of capital that promotes investment in an industry and above the (risk-adjusted) cost of capital that promotes expansion and investment in a competitive economy. Perhaps most importantly it is economic rates of returns, and expected future cash flows that determine the value of the company.*

<sup>1</sup> The views expressed herein are solely the author's and do not necessarily reflect the views of the Saudi Arabian Oil Companies or its affiliates.





*Accounting rates of return are useful only insofar as they yield information that can be used to calculate economic rates of return. It should go without saying that the accounting rate of return on a given investment, which is defined as the net revenue to book value in a given year, will be equal to the economic rate of return, which is defined as the rate which makes the present value of the entire stream of net cash flows equal to the initial capital cost, only by coincidence. Indeed, there is no reason for us to expect these rates even to be close. Profits as reported by accountants may differ from firm to firm and industry to industry and they are not consistent with economic concepts of profits, which include the opportunity cost of all inputs in the production process, including of capital. Thus, even if properly and consistently measured, accounting rates of return provide almost no information of economic rates of return.*

*Worse, it is easy to construct cases where firms with higher accounting rates of return have lower economic rates of return and vice versa. Moreover, accounting rates of return on individual investments generally vary from year to year and depend crucially of the time shape of the investment. Only if such fluctuations are averaged out by combining different investments over time will a firm's accounting rate start to be roughly constant, yet still not approximate the economic rate of return. If firms do not show the very substantial variability in accounting rates of return of single investments in practice, it is because they are growing and attribute profits from past investments to the book value of new projects whose profits are yet to materialize, rather than to the declining book value of such past investments. While this sort of averaging stabilizes accounting rates of returns it also makes them less comparable conceptually to the economic rate of return.*

While the RP method is well-suited for the simple exchange of goods, the CUP method or the C+ method, the latter especially in the guise of the ROR method, are best suited for transactions that resemble longer term relationships or the provision of a service well into the future.

For the CUP method the accuracy of the transfer price stands and falls with the choice of suitable comparable transactions. In practice, the analyst will have access to bespoke databases. The advantages of the methodology are twofold: First, given a sufficient number of observable transactions, the estimate is very reliable. Second, because the transfer price is independent of the conduct of the controlled parties, the method does not distort incentives. The downside is that adjustments to the observed prices for special circumstances are difficult. For example, to establish a transfer price in Saudi Arabia may be difficult if most comparables are based on the U.S., which is often the case given that the U.S. often represents the most liquid, active and transparent market.

The ROR method can best be understood as the approach adopted by most regulators of natural monopoly. ROR regulation seeks to allow the regulated entity a rate of return close to its cost of capital, which is what the utility would stand to achieve in long-run competitive equilibrium. The rate has to be an economic rate of return as explained by Fisher and McGowan, it is useful to think of a target IRR. While simple cost-plus regulation may create perverse incentives by enticing the regulated entity to inflate its capital base, there are ways to mitigate this tendency. These include redetermination periods of several years during which the regulated entity will benefit from any outperformance, efficiency factors requiring the regulated entity to improve operations or profit-sharing mechanism if certain targets are exceeded. Just as the regulator can achieve an alignment of incentives, so the proper use of transfer prices between different entities in controlled transactions ensures overall alignment of incentives at the company level. An added advantage is that projections may be based on a company's business plan, and the target return on the Weighted Average Cost of Capital, adjusted for industry and jurisdiction, for example by using an asset pricing model such as CAPM.

## Conclusions

If the objective of the choice of transfer pricing method is a mere minimization of the tax bill, any method that achieves the task will do. However, if the objective is more ambitious and includes an alignment of incentives and the efficient running of operations, economic metrics are vastly superior. Indeed, the added benefits from efficient and incentive-compatible transfer pricing may result in benefits that outweigh tax savings. This is ultimately an empirical question, which awaits further investigation.

## References

OECD Transfer Pricing Guidelines for Multinational Enterprises and Tax Administrations 2022

Franklin M Fisher and John J McGowan: On the Misuse of Accounting Rates of Return to Infer Monopoly Profits American Economic Review, 1983, vol. 73, issue 1, 82-97





## *CASH-FLOW-AT-RISK*

Shamsul Anuar, FCA, CFA, CQRM • +966 13 873 5526 • shamsul.anuar@aramco.com

### **Overview**

We introduce a methodology to analyze the long-term projection and the associated risks of a company's future cash flows. The enhanced methodology is designed to support, not replace any existing analysis.

The Cash-Flow-at-Risk methodology supports management to make business decisions with a clear view on the effect on the possible outcomes on the cash flow levels in any given year. The analysis helps to support management through:

- articulating the distribution of projected cash flows and assessing the likelihood of meeting certain targets such as the company's dividend commitment.
- assessing financial risk to be able to set, monitor and enforce agreed levels of financial risk appetite at the corporate level or any business levels.

Cash-Flow-at-Risk analysis requires simulation to be run stochastically to determine the range of possible outcomes for the overall company financial projections, based on assumed distribution of parameters (Monte Carlo simulation). The analysis provides a description of the risk-reward characteristics that is superior compared to a deterministic single point estimate.

### **Methods**

The traditional approach is to perform scenario analysis to determine possible financial outcomes under alternative assumptions. This approach remains an important tool of the cash flow analysis. However, there are drawbacks to this approach. Each scenario analysis shows a single alternative outcome; only one variable can be changed at a time, and; there is no way of assessing how probable the stress scenario is.

Cash-Flow-at-Risk analysis provides a superior way of analyzing uncertainty inherent in the financial forecast. It provides a tool that allows us to assess the spread of possible outcomes and also assign probability to certain outcomes, most importantly the probability that we will achieve a certain cash flow target. The analysis is also more flexible than traditional scenario analysis or stress testing in that many variables that drive cash flows can be changed and the joint effects on cash flow examined. The spread of outcomes is also crucial in supporting decision making, for example in planning for a safety margin, and in reviewing acceptability of extreme outcomes.

A major benefit of Cash-Flow-at-Risk analysis is the ability to provide management with the understanding of risk factors and drivers that affect the Company cash flows. These drivers are factored in as the distribution of the assumptions that drives the cash flows.

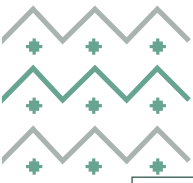
The Cash-Flow-at-Risk analysis relies on assumptions that are robust, ideally applying forward looking data based on the market expectations where available.

### **Results**

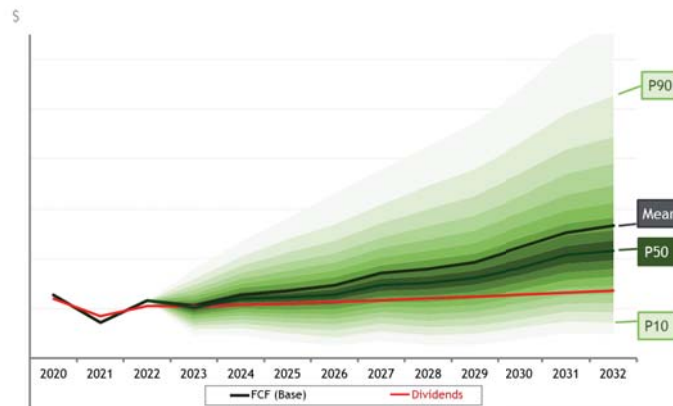
The total cash flows are calculated from the stochastic simulation of its constituent parts, based on probability distributions as described above. The resulting distribution of total cash flows can be analyzed, and be associated with probability distribution. The chart below illustrates an example of total cash flows (free cash flow to equity) over 10 years, together with the spread of its likely outcomes.







Cash-Flow-at-Risk: Fan Diagram



In summary, the above chart shows the expected envelope of free cash flow to equity, and the threshold of probabilities.

The cash flow result from this stochastic analysis can be compared against a target cash flow, in the example above the red line represents the dividend level that has been committed to.

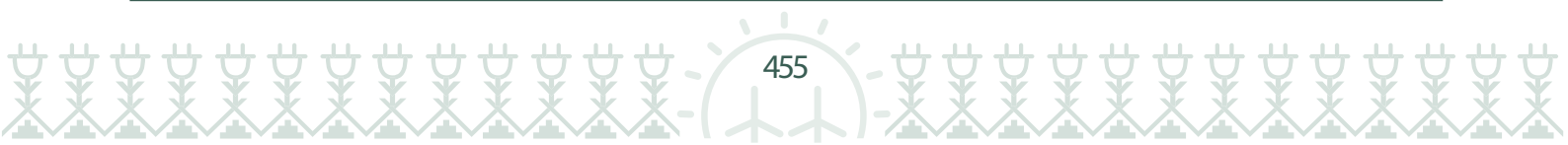
One of the major conclusions of the stochastic analysis is in revealing the risk of not meeting the target, a risk that is not apparent in the scenario analysis. Even under the stress scenario in the deterministic case, this risk is concealed as it may show the targets are met hence giving a false sense of security, as in reality there is still sizable chance that this will not be the case.

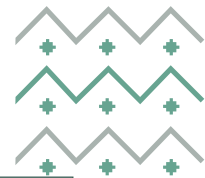
The same methodology above can also be easily applied to the business to assess the probability of meeting certain cash flow targets at the business segment or business unit levels.

### Conclusions

The enhanced methodology allows quantification of the company's financial risks through the measure of Cash-Flow-at-Risk. Analogous to a bank's or financial institutions' trading portfolio, the company's portfolio of real assets could be analyzed using stochastic analysis and a value-at-risk established based on the volatility of future cash-flows.

The quantitative analysis allows the financial risk appetite to be established, gauged and tracked over time, in support of other qualitative assessment.





## A FIRST ASSESSMENT OF THE EU TAXONOMY AND ITS IMPACT

Susanna Dorigoni, O-FIRE, University of Milano – Bicocca and GREEN, Bocconi University, Milan,  
susanna.dorigoni@unibocconi.it

Lucia Visconti Parisio, O –FIRE, University of Milano – Bicocca , lucia.parisio@unimib.it

Paola Galfrascoli, O –FIRE University of Milano – Bicocca

### Overview

As stated during COP1 26 in Glasgow, the need for a change in economic growth system in the environmental and social sense and, in particular, of a radical energy transition is emerging in a disruptive way. The Russian-Ukrainian conflict and the consequent implications on the energy markets, characterized by unprecedented price increases make it even more necessary to adopt a new economic development paradigm. The latter is requiring and will require in the future to be sustained by huge investments. In this connection, the cooperation among public and private sector will be fundamental and the contribution of financial markets and institutions will complement public investments and incentives to reach the target.

According to the Global Sustainable Investment Alliance, in 2021, the value of professionally managed portfolios that have integrated key elements of ESG exceeded USD 17.5 trillion globally.

The above-mentioned growth is due to at least three factors:

- market evidence in many economic sectors suggest that ESG investing can help improve risk management and lead to returns that are higher than traditional financial investments;
- growing societal attention to climate change, the benefits of responsible business conducts, the need for diversity in workplaces and boards is affecting corporate performances;
- the necessity to move away from short-term perspectives of risks and returns so as to better reflect longer-term sustainability in investment performance.

### Methods

The study analyses the trend of ESG investments at global and European level and describes the current economic and energy landscape, with particular reference to the description of the reference regulatory context. We analyze the first Delegated Act on mitigation and adaptation to climate change, the supplementary delegated act relating to natural gas and nuclear power, the Directive on non-financial information and its revision. A simplified "reading" of the same taxonomy is subsequently provided, for the moment with exclusive reference to the objective of climate mitigation and with a first focus on the sectors most responsible for climate change itself: energy and transport. The analysis is then extended to all other economic activities contemplated in the taxonomy. We devote particular attention to the Technical Screening Criteria (TSC) that determine the degree of sustainability of the "eligible" activities.

We analysed 5000 observations of firms registered in the MSCI database, considering 1391 EU big firms for a total turnover of approximately \$10 Bln; the energy and transport industries represents the 29% of the total. Among the 826 ESG variables considered, 370 are environmental variables (E) related to several elements, including emissions, carbon footprint, renewable sources, efficiency energy, water consumption, biodiversity and land use.

The series of variables considered coincide or have a high degree of compatibility with those on which the taxonomy Technical Screening Criteria (TSC) are based, with the aim of providing a preliminary assessment of any mismatch between the actual features of business activities and those required by compliance with the taxonomy rules, as well as between information that companies make publicly available to date and those that will instead be required on the basis of the new non-financial reporting obligations. In fact, this assessment makes it possible to formulate a preliminary judgment on the impact of taxonomy on the economic sectors considered.

### Results

From the analysis conducted, it emerged that the EU taxonomy undoubtedly represents a forward-looking regulation designed to radically change the paradigm of economic growth on the basis of new environmental and social goals. It also represents a historic opportunity for the modernization of the productive system and for a sustainable economic growth, but it will not be risk-free in as it will require huge investments linked to the necessary changes in the strategy of companies and the new reporting and disclosure obligations. These could put some enterprises, particularly the smaller ones, or even some industries, in a difficult position, also considering the current complicated geopolitical, economic and energy context. The analysis has highlighted some initial insights on a very composite scenario where



just a few companies have really embarked on a well-defined path of decarbonization, minimization and recycling of waste, energy efficiency or rationalization of water consumption.

A substantial effort, both on the economic and the management side, is hence required in the short term.

In fact, since the compliance with the taxonomy is not mandatory (except for the reporting activity), and it does, therefore, not require (often long) transposition and implementation times at the national level (typical of other legislations), it is paradoxically destined to exert its influence on companies and financial markets immediately.

## Conclusions

In general, it can be said that the impact of the EU taxonomy could be considerable in terms of:

- investments: both for companies that will have to make their activity compliant with the new regulation and for financial institutions that will have to pay attention to the composition of their portfolios;
- reporting and non-financial communication: for companies and financial operators who will have, starting from the current year, to review their non-financial communication both from a qualitative and quantitative point of view, and for rating agencies that will have to use new and uniform parameters for the processing of their scores;
- access to credit: for companies that do not carry out sustainable activities, we expect an increase in the cost of capital, with a significant impact on the equilibrium of industries.

Such impact will intensify once the the criteria for the other four environmental objectives and the social taxonomy are issued.

## References

Commission Delegated Regulation EU 2021/2139

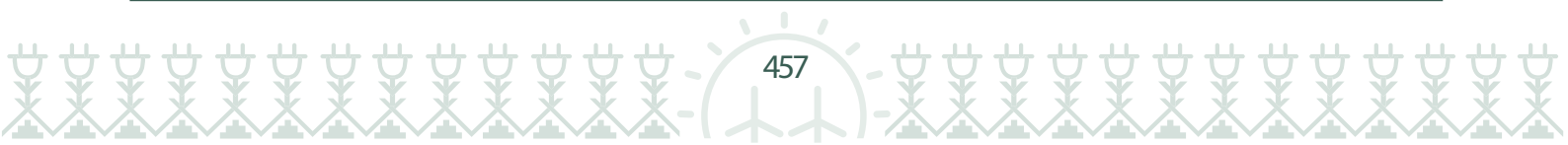
Directive 2000/60/EC

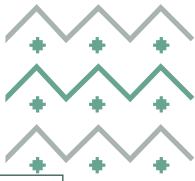
Directive 2011/92/EU

Directives 2009/147/EC and 92/43/EEC

Regulation (EU) 2020/852 (Taxonomy) on the establishment of a framework to facilitate sustainable investment

Regulations EU 2019/1021, 2017/852, 1005/2009, 1907/2006





## ***Incorporating ESG indicators into financial models for hydrogen assets***

Giannakidou Georgia , Audencia Business School, ggiannakidou@audencia.com, +306973459946  
Georgiadis Nikolaos, Hellenic Association for Energy Economics, n.georgiadis@haee.gr, +306978643205  
Andriosopoulos Konstantinos, Audencia Business School, kandriosopoulos@audencia.com, +306947042013

### **Overview**

The financial system is shifting towards sustainable and green investments. This transition has already started to systematically incorporate and disclose information on ESG indicators into business practices, valuation models, and decision-making processes, directing capital flows and creating additional incentives for portfolio managers and multinational enterprises.

### **Methods**

The study is considering a plethora of relevant Environmental, Social and Governance indicators that are widely used in Sustainability reporting of Large Enterprises and their linkages with a financial model that is developed for a green hydrogen asset in Greece. Two plausible scenarios will be developed, one associated with a business-as-usual norm without incorporating ESG indicators into the business model while the second integrates ESG performance. The aim of this method is to compare the two alternative trajectories and draw useful insights for the role of ESG indicators in hydrogen investments. A hydrogen investment opportunity in Greece will be the case study on which dependent variables such as ROA, ROE, ROIC, and Tobin's Q will be applied to explore the correlation between financial and ESG performance, by modeling and creating scenarios on ESG indicators and investment values.

### **Results**

The purpose of this paper is to analyze how the disclosure of ESG indicators could affect traditional valuation approaches - business models and competitive positions - in hydrogen projects, by studying the ESG impact on market and reported firm performance. The results compare a business-as-usual (BAU) scenario and the ESG integration (ESGI) scenario. The outcomes depict the role as well as the level of profitability of ESG indicators when included in the financial analysis. Additionally, it correlates the selected quantifiable ESG indicators with the relevant components of the financial model and examines its impact on the financial outcome.

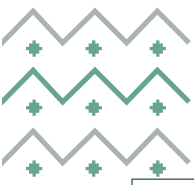
### **Conclusions**

The assessments are in the final stages but not yet finalized.

### **References**

- [1] Renneboog L., Ter Host J., Zhang C, "Socially responsible investments: Institutional aspects, performance, and investor behavior," *Journal of Banking and Finance* 2008;32, 1723–1742.

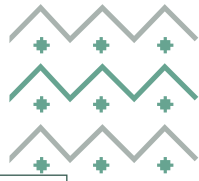




- [2] Amel-Zadeh A., Serafeim G., "Why and how investors use ESG information: Evidence form a global survey", *Harvard Business School Accounting & Management Unit Research Paper Series*
- [3] Zhao C., Guo Y., Yuan J., Wu M., Li D., Zhou, Y., Kang, J., "ESG and Corporate Financial Performance: Empirical Evidence from China's Listed Power Generation Companies Sustainability", 2018;10, 2607.
- [4] Velte P., "Does ESG performance have an impact on financial performance?" Evidence from Germany", *Journal of Global Responsibility* 2017.
- [5] William D., Malcolm E., "Forecasts, scenarios, visions, backcasts and roadmaps to the hydrogen economy: A review of the hydrogen futures literature", *Energy Policy* 2006







## ***THE IMPACT OF WORLD POPULATION GROWTH ON GLOBAL ENERGY CONSUMPTION: A PROBABILISTIC ANALYSIS***

Peter Pflaumer, Department of Statistics, Technical University of Dortmund, Germany, Email: peter.pflaumer@tu-dortmund.de

### **Overview**

Apart from the price of energy, there are two influencing factors that control global primary energy consumption, namely the total number of people in the world and the average per capita energy consumption of each individual. While per capita energy consumption is falling in a large part of the OECD countries, it is rising in other countries, e.g., in the Middle East. A global energy demand forecast to 2050 is presented, based on historical growth in per capita energy consumption over the period 1965-2021 and on United Nations population projections.

### **Methods**

Average per capita energy consumption is forecast using modern time series models, the Autoregressive Integrated Moving Average (ARIMA) models. Finally, the results of the time series forecasts are combined with stochastic UN world population projections to obtain forecasts and prediction intervals of total energy consumption from 2022 to 2050. We use autocorrelation function (ACF) and the partial autocorrelation function (PACF) in tandem to identify the stochastic process of per capita energy consumption between 1965 and 2021. ACFs and PACFs together with the mean of the first differences indicate an ARIMA(0,1,0) model with drift. More complicated ARIMA models were also considered, specified, estimated and used for forecasting. An alternative would have been an ARIMA(0,1,1) model with drift. However, we were always aware of the principle of parsimony which means that in a set of predictive models, the simplest possible models should be chosen. Assuming a normal distribution, the standard deviations or variances of total primary energy demand are determined from the limits of the given prediction intervals of per capita consumption and world population.

### **Results**

The forecasts of the global per capita energy consumption are shown in Table 1. In 2050, the point forecast for the world per capita consumption is 90.6 GJ, which corresponds to an annual (steady) growth rate of 0.62 percent between 2050 and 2022. We describe the uncertainty by the 95% prediction interval. The lower bound is 77.4 GJ and the upper bound is 103.8 GJ in 2050. The mean forecast values from 2022 to 2050 as well as the resulting limits of the 95% forecast intervals of world total primary energy consumption are shown in Figure 1. In 2050, the median forecast is 879.3 EJ. The 95% forecast interval ranges from 748.2 EJ to 1010.4 EJ. The prediction intervals clearly show the growing uncertainty with increasing forecast horizon. In addition, the influence of population and per capita consumption on the forecast is analyzed. The median forecast of total energy consumption leads to an average annual growth of 1.32 percent, whereby the influence of the world population, which grows 0.70 percent annually, is somewhat higher than the per capita energy consumption, which increases 0.62 percent annually. Conditional forecasts show that the uncertainty in forecasting total primary energy consumption is mainly due to the uncertainty in forecasting per capita energy consumption (see prediction intervals in Table 1), whose prediction intervals are much larger than those of the world population.



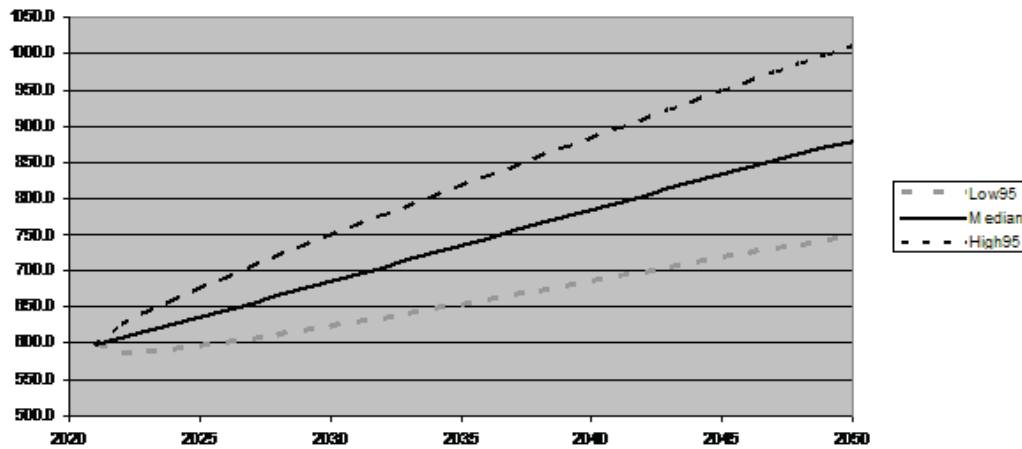
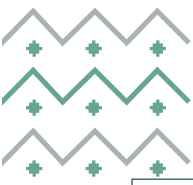


Fig. 1. Forecast of the world primary energy consumption with 95% prediction intervals (exajoules)

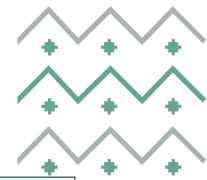
Table 1. Forecasts of primary per capita energy consumption (gigajoules)

Year	Forecast	Lo 80	Hi 80	Lo 95	Hi 95
2025	77.7	74.5	80.9	72.8	82.6
2030	80.2	75.4	85.1	72.9	87.6
2035	82.8	76.8	88.8	73.7	92.0
2040	85.4	78.4	92.4	74.7	96.1
2045	88.0	80.1	95.8	76.0	100.0
2050	90.6	81.9	99.2	77.4	103.8

## Conclusions

The prediction of global primary energy consumption is based on a combination of the prediction of per capita energy consumption and the prediction of world population. The results clearly show that total primary energy consumption depends on both future per capita energy consumption and future population growth, with both variables having about the same influence. In contrast, the uncertainty in the global energy forecast is largely driven by the uncertainty in the per capita primary energy consumption forecast, although the future of world population growth appears more uncertain today than it did a decade ago due to stagnant fertility decline in some African countries. The proposed model uses only past values for forecasting. Causal factors affecting energy demand are not considered. Time series methods for forecasting the future are suitable as long as demographic, social, political, and economic change is slow, continuous, and without breaks or sudden changes in direction, and the past, present, and future differ only slightly.





## ***OPTIMAL PLANNING AND OPERATION OF ISOLATED MICRO-GRID FOR SUSTAINABLE DEVELOPMENT***

Mohammed M. Mishref, Graduate School of Policy Studies, National Graduate Institute for Policy Studies (GRIPS), Tokyo, Japan, 08078239530, doc21153@grips.ac.jp

Makoto Tanaka, Graduate School of Policy Studies, National Graduate Institute for Policy Studies (GRIPS), Tokyo, Japan, mtanaka@grips.ac.jp

### **Overview**

People living in remote areas account for 13% of the global population [1]. They usually suffer from a lack of electricity connection, which increases their reliance on diesel generators. The dependence on fossil fuels as the primary source of electricity generation is unsustainable due to fluctuating fossil energy prices and high emission values [2]. Renewable energy resources could solve this problem, but their intermittent nature is another issue. Hybrid renewable energy, which combines renewable resources such as PV and wind with backup resources like batteries and standby generators, could be promising for achieving sustainability and flexibility in isolated microgrids [3]. A backup generation of diesel, a micro-turbine, or a fuel cell is mandatory in an isolated grid, because battery storage is unreliable [4]. The primary source of charging the battery is the surplus energy of renewable resources from PV and wind. Surplus energy may not always be sufficient to charge the electrical battery, necessitating a backup generator. Although using diesel and micro-turbines as backup resources in isolated micro-grids is less expensive than fuel cells, the emissions are higher [5]. Using a fuel cell requires a source of hydrogen, while importing hydrogen from other prefectures may incur high transportation costs and risks. Using an electrolyzer for generating green hydrogen from surplus energy is not a stable hydrogen supply. The electrolyzer and the reformer combination can provide secure hydrogen production to supply the fuel cells or any other application.

This paper will identify the optimal hybrid renewable for net present cost minimization in an isolated microgrid while considering net-zero emissions. It will specify the optimal dispatch of PV, wind, battery storage, and fuel cells when using an electrolyzer and a steam reformer with carbon capture utilization and storage (CCUS). It will also consider power-to-gas (P2G) to power process (P2H2P) for supplying the fuel cell. The steam reformer modeling will be part of a combined heat and power system (CHP) to reduce emissions and costs of CCUS. The management strategy for the electrolyzer and the steam reformer will be highlighted to reduce the cost of hydrogen generation in the isolated microgrid, which reduces the overall cost. It will try to display hydrogen between both devices optimally, considering the mid-term storage and its fluctuation in the natural gas price. The study will be applied in two isolated systems in Egypt, isolated from the main grid, which use a diesel generator to supply the electrical load.

### **Methods**

This research will determine the best hybrid renewable between PV, wind, battery, and the fuel cell's in an isolated microgrid considering hydrogen from electrolyzer and steam reformer with CCUS for achieving carbon neutrality. The objective function is net present cost minimization (NPC). The management strategy will be based on determining the optimal operating periods for the electrolyzer and reformer with CCUS to reduce the overall cost of the microgrid. Homer Pro optimizer software will be used for micro-grid modeling, and additional assumptions will be added to the model using Matlab software to display the thermal load of the steam reformer and management strategies. The research will be conducted in two isolated systems, the first in East Owinat in Egypt's western desert and the second in a remote location near Minia prefecture. Both systems are disconnected from the main grid and used for supplying residential loads and submersible pumps for acres reclamation.



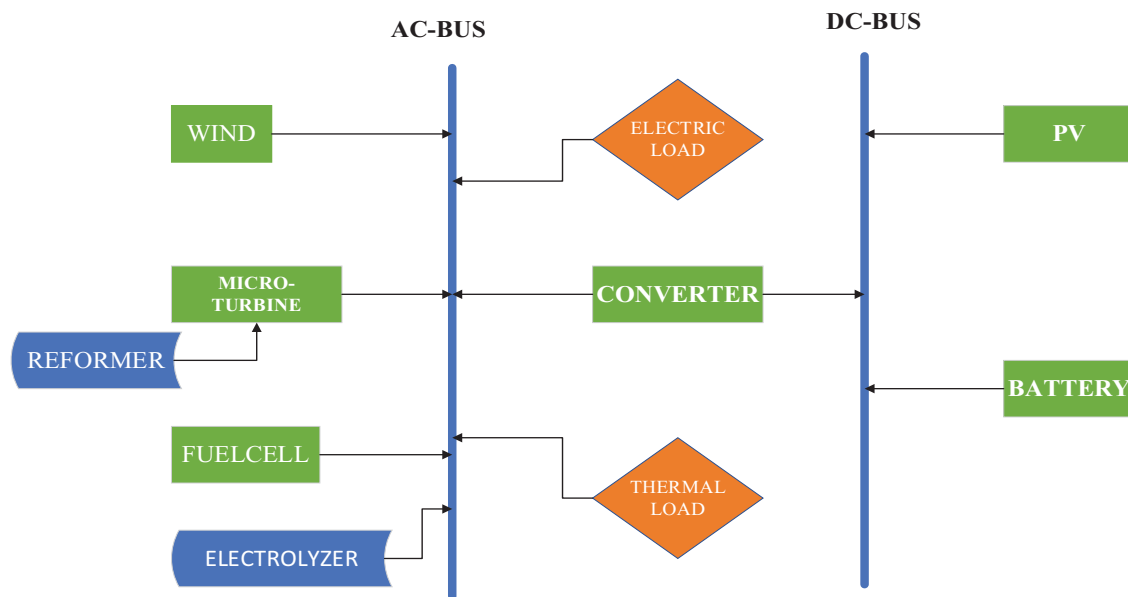


Fig. Main Microgrid Components

## Results

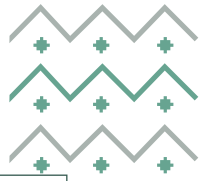
The results will show the optimal dispatch of PV, wind, battery storage, and fuel cell for net present cost minimization. It will demonstrate the benefits of using P2H2P to supply fuel cells in reaching net zero emissions. The model will use an electrolyzer to generate hydrogen from surplus energy and directly from the micro-grid. It will also show the modeling of the steam reformer as a part of the combined heat and power (Chp) of the microgrid and its impact on reducing the cost of CCUS. The optimal operation of the electrolyzer and the reformer is another concern. The study will demonstrate management strategies' role in displaying the electrolyzer and reformer with CCUS in reducing the overall system cost.

## Conclusions

Isolated grids, particularly in Africa and Asia, pose a significant threat to the environment, with many still relying on diesel generators and burning wood for stoves and heating during the winter. Hybrid renewable energy will be a promising solution for carbon neutrality and increasing system flexibility. In remote areas, hydrogen is critical for supplying fuel cells as an essential backup resource. The study will elaborate the optimal dispatch of PV, wind, battery, and fuel cell for the net present cost minimization as an objective function, considering electrolyzer and steam reformer with CCUS. It will show the importance of management strategies between the electrolyzer and the steam reformer with CCUS in reducing the overall cost of the microgrid. It will also suggest three management strategies for providing hydrogen for P2H2P process. The study will achieve sustainability by replacing diesel generators with fuel cells driven by hydrogen generation, using Chp to provide heat for the reforming process to reduce the reliance on natural gas, and using management strategies for reducing the hydrogen Levelized cost and the entire microgrid cost.

## References

- 1- N. Ninad, D. Turcotte, and Y. Poissant, "Analysis of PV-diesel hybrid microgrids for small Canadian arc communities," *Can. J. Electr. Comput. Eng.*, vol. 43, no. 4, pp. 315-325, 2020, doi: 10.1109/cjece.2020.2995750.
- 2- A. Guerello, S. Page, G. Holburn, and M. Balzarova, "Energy for off-grid homes: Reducing costs through joint hybrid system and energy efficiency optimization," *Energy Buildings*, vol. 207, Jan. 2020, Art. no. 109478, doi:10.1016/j.enbuild.2019.109478
- 3- A. A. Eajal, A. El-Awady, E. F. El-Saadany, K. Ponnambalam, A. Al-Durra, A. Al-Sumaiti, and M. Salama, "Bayesian approach to the reliability analysis of renewables-dominated DC microgrids," *IEEE Trans. Power Syst.*, early access, Feb. 3, 2021, doi: 10.1109/TPWRS.2021.3056314
- 4- B. Hodge, *Alternative Energy Systems and Applications*, 2nd ed. Hoboken, NJ, USA: Wiley, 2017, pp. 143-167.
- 5- E. G. Vera, C. Canizares, and M. Pirnia, "Renewable energy integration in Canadian remote community microgrid: The feasibility of hydrogen and gas generation," *IEEE Electrical Mag.*, vol. 8, no. 4, pp. 36-45, Dec. 2020, doi: 10.1109/MELE.2020.3026438.



## Forecasting Solar Irradiance in Saudi Regions Via Machine Learning & Artificial Neural Networks

[Subah M Alkhalidi, Saudi Aramco, 00966501548517, [subah.m.alkhalidi@gmail.com](mailto:subah.m.alkhalidi@gmail.com)]

### Overview

Solar irradiance intensity, abundance and predictability are critical parameters in the design and operation decisions of solar energy systems. Data collection points (i.e., solar irradiance measuring devices) are not widely utilised in Saudi Arabia. This poses great importance in developing methods of extracting valuable information from available data. The objective of this paper is to assess the viability of solar energy system locations through investigation of irradiance predictability of Saudi regions. In this project, Saudi Arabian weather is employed for an examination of machine learning algorithms with the use of multiple parametric data provided by public domain entities including Photovoltaic Geographical Information System (PVGIS), King Abdullah City for Atomic and Renewable Energy (KACARE) and mainly the National Renewable Energy Laboratory (NREL). The models use quantitative measures for accuracy such as Mean Absolute Error (MAE), Root Mean Square Error (RMSE) and the Coefficient of Determination (R) for both Machine Learning and Long-Short Term Memory techniques.

### Methods

In this paper, both traditional machine learning models and state-of-the-art Long-Short Term Memory are analysed and compared. First, Exploratory Data Analysis is conducted giving a holistic view on the current trends and seasonality effects. Before applying any method, the raw data is processed and cleaned from any abnormalities, missing values, outliers and flagged values of low quality. While methods are implemented, trade-offs are stated in the analysis between bias and variance. Additionally, Hyperparameter tuning with both Principal Component Analysis (PCA) and K-Fold Cross-Validation are discussed. The analysis is conducted through multiple temporal horizons (daily, weekly, and monthly) to assess the capabilities of the models and the observed effects such as daylight and night as high frequency events and seasonality for lower frequencies.

### Results

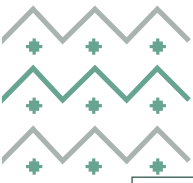
The most accurate performing model for daily predictions seems to be always under the family of 'Gaussian Process Regression' models for all locations of interest which seems to correspond with the expectation of non-parametric flexible models performing better than the others due to their low intrinsic bias. It is also shown that for the long temporal horizon to be predicted (i.e., the 5<sup>th</sup> year for all locations in this case), predicting longer periods of time gives generally better performance, monthly followed by the weekly and daily respectively since for daily it is highly noisy, requiring low pass filtering, relative to such a long horizon.

Models with lower performance for specific locations, such as Abha, indicate that such locations might be intrinsically hard to predict. This can be explained with multiple factors such as geographical location, climate and height. To verify findings, data were benchmarked and it is shown that through a 31-day moving average the sources of data converge to similar values. This presents the accuracy of the data used for analysis.

Lastly, model agnostic interpretability of the black box machine learning model is conducted with the use of individual conditional expectation (ICE) charts as well as M-plot correlations to uncover hidden patterns.







### Conclusions

Solar Global Horizontal Irradiance (GHI) is predicted through both machine learning and long-short term memory data analysis techniques showing different predictive potentials from the available data. It is concluded that:

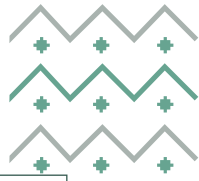
1. Predictions of solar irradiance through utilisation of machine learning and long-short term memory provide critical insights into the predictive potentials of Saudi Arabian Regions.
2. Machine learning excels in short temporal horizons whereas long-short term memory method performs better in long-term trends.
3. Model agnostic techniques for enhancing interpretability of the black box machine learning model have been conducted and show the relation between features (temperature and relative humidity) and the response variable (GHI).

This analysis could be further developed to include a detailed explanation of the extent of the effect of geo-climatic modelling as well as various temporal horizons. In addition, further investigations to the boundaries at which the models perform with the least cost and highest efficiency should be done to clarify their limits and provide potential justifications.

### References

In the full paper.





## GLOBAL OIL INVENTORY RESPONSES TO GEOPOLITICAL SHOCKS

[Philipp Galkin, King Abdullah Petroleum Studies and Research Center, 966112903194, philipp.galki  
[Jennifer Considine, King Abdullah Petroleum Studies and Research Center, 966112903000, jennifer.considin  
[Emre Hatipoglu, King Abdullah Petroleum Studies and Research Center, 966112903162, emre.hatipogl

### Overview

Inventory level is seen as one of the major indicators of the global oil market by analysts and policymakers (2021, Nasdaq 2022). It is driven by the market fundamentals, such as shifts in supply and demand, as well as operational, security and speculative considerations of market participants. Hence, the level of oil inventory is affected by the shocks in the global oil market and global economy in general, as such shocks represent a disturbance of market equilibrium caused by a change in a supply or demand determinant.

Recently, the occurrence and magnitude of economic and geopolitical shocks impacting the global oil market intensified, putting a spotlight on subsequent reactions of market indicators. In the case of crude oil stock response has not been uniform and not always aligned with the theoretical frameworks. Presumably, in response to a supply shock, oil inventories should increase as market players anticipate higher future prices and potential shortages. Only after a certain period the inventory level is expected to fall as the shock is absorbed by the market. However, a variety of historical response patterns has been observed depending on the location of stocks and market conditions (Caffarra 1990).

This study aims to contribute to understanding of potential responses of oil inventory levels to supply shocks by modelling such impacts for specific economies and under various market conditions.

### Methods

To assess the effect of external economic and political shocks on oil markets, we adopt a counter-factual approach. We utilize the KAPSRAC global vector autoregression oil and inventory model (GOVAR), a structural VAR model, which was developed to assess the effects of hypothetical economic and political shocks to the oil market (Considine et al. 2021). The model builds upon the GVAR model developed by Mohaddes and Pesaran (2016), which covers 33 countries quarterly from 1979Q4 to 2015Q4.2 Our additions to Mohaddes and Pesaran include the modification of the price equation and country-specific models to incorporate a new variable, oil inventories, the extension of the dataset to 2022Q1, and the addition of three major oil-producing countries: Russia, and Venezuela. Resulting model characteristics make it particularly suited to this analysis: First, the extended GVAR framework captures the interactions between many countries. Second, world oil supplies and inventories are modelled jointly with key global and country-level macroeconomic variables.

We run two sets of counterfactual scenarios that represent different oil market conditions: "tight" oil market conditions in 2022Q1 and "loose" market based on 2018Q3 data. Under each set of scenarios, we – in turns – shock (reduce output of oil producers: Iran, Russia and Mexico and explore the impacts of these shocks on oil inventories at country and global scales.

### Results

Induced oil supply shocks generate a heterogeneous response across the observed economies. Japan and South Korea in most scenarios tend to increase their stock level, while the US and the UK reduce their inventories. Such divergence has been observed in reality: historically – in response to the Gulf crisis of 1990 (Caffarra 1990) and more recently during the conflict in Ukraine. In the latter case, oil inventories in Japan and South Korea increased from February to April, followed by a drawdown induced by the SPR release coordinated by the US and the IEA. The oil stock in the US during this period, conversely, have been consistently declining (JODI 2022).

The impact of supply shocks on oil inventories also varies depending on which supply source is affected. A cut in production of Russia leads to a clear division in response among western (US, UK, Canada) and eastern (Japan





Korea) economies, where the former reduce their oil stocks and the latter – increase. Shocking Iran's output results in a more mixed response: inventories in South Korea decline in contrast with the increase in Japan (Japan responds consistently across all scenarios) and with the quick rebalancing observed in the US and UK. Finally, reduction in oil supply from Mexico induces a nearly uniform increase in oil inventories in the economies in question.

Finally, movements in oil inventories seems to be conditional on the state of the market. Expectedly, under "loose" market conditions (characterized by higher baseline inventory levels) supply shocks eventually result in lower oil stocks compared to the "tight" market settings. "Loose" market also tends to rebalance quicker if the initial reaction is to decrease the level of inventories. Similarly, the "tight" market demonstrates faster absorption of initial shock marked by the inventory buildup. This behavior is observed in reality and can be explained by the desire of market participants to capitalize on higher prices resulting from the shock and by the desire of policymakers to balance the supply and demand through inventory release.

## Conclusions

Economic and geopolitical shocks tend to reverberate through global oil markets in a variety of patterns. Despite the global nature of the crude oil market, the response of oil stocks to such supply-side shocks is defined by the affected producer(s), behaviour of specific importers and the general state (defined by the pre-shock inventory levels) of the market. This variability makes it extremely difficult to predict the new market equilibrium, which would emerge from unexpected or planned (e.g. resulting from sanctions) market disruptions. Specifics of bilateral trade relations and varying pre-existing market conditions may result in unexpected consequences of such policy interferences.

Moreover, potential policy responses to market shocks (SPR release, protectionist measures among others) can distort the market balance. Such policy scenarios (or historical precedents) need to be taken into account for better understanding of how these markets function.

However, our simulations confirm certain patterns in how oil inventories react to supply shocks depending on market conditions and importing countries, confirming the applicability of the GOVAR model to the problem in question. Further research lines may focus on exploring the behaviour of oil product stocks – diesel and gasoline – and the balance of crude and products inventories in response to market shocks.

## References

Considine, Jennifer, Emre Hatipoglu, Abdullah Aldayel, 2021. The sensitivity of oil price shocks to preexisting market conditions: A GVAR analysis. *Journal of Commodity Markets*, 27.

<https://doi.org/10.1016/j.jcomm.2021.100225>

Gaffarra, Cristina. 1990. *The Role and Behaviour of Oil Inventories*. Oxford Institute for Energy Studies. ISBN 0 948061 43 X.

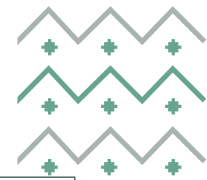
JODI. 2022. The JODI Oil World Database. Accessed on August 25. <https://www.jodidata.org/oil/>

Kamiar, Mohaddes and Hashem Pesaran. 2016. Country-specific oil supply shocks and the global economy: a counterfactual analysis. *Energy Economics*, 59 (C), pp. 382-399. <https://doi.org/10.1016/j.eneco.2016.08.007>

Nasdaq. 2022. Low U.S. oil inventories imply deeper economic slowdown will be needed. July 28. <https://www.nasdaq.com/articles/column-low-u.s.-oil-inventories-imply-deeper-economic-slowdown-will-be-needed:-kemp>

OPEC. 2021. *OPEC Monthly Oil Market Report*. November 11. Vienna, Austria.





## FLEXIBILITY REQUIREMENTS AND INCENTIVES FOR STORAGE INVESTMENTS IN FUTURE EUROPEAN POWER SYSTEMS

[Derck Koolen, European Commission: JRC Dir. Energy, Transport and Climate, +31 224 56 5958, derck.koolen@ec.europa.eu]

### Overview

The transition to a climate neutral energy system is accompanied by an increasing share of renewable energy sources in European electricity grids. As the production of renewable energy sources is inherently variable, flexibility needs to balance supply and demand are expected to grow in the years to come. In this work, we study the flexibility requirements and incentives for investing in storage technologies in the 2030 and 2050 European power system using the METIS energy system model. We find the flexibility needs to increase significantly, with variable renewable energy output the main driver behind growing flexibility requirements at different timescales. We address which technologies, including storage, may provide flexibility solutions in addressing the flexibility needs and assess the economic value of financial arbitrage for such flexibility technologies in the spot market. We further study, in relation to storage investment costs and available interconnection capacity, the optimal fleet of electricity storage solutions to accommodate flexibility needs in future European power systems.

### Methods

We model the European power system with METIS, a mathematical model simulating the operation of the European energy system, representing each Member State of the EU and relevant neighbouring countries. The model enables us to optimise (technological) parameters from a system cost perspective, by jointly performing capacity expansion and hourly dispatch simulations.

The METIS energy model simulates the clearing of the short-term power market, using fundamental input data on installed production capacities and commodity price costs, on an hourly basis over a given year. In the context of this study, the model allows us to address flexibility needs in relation to the variable nature of demand and variable renewable energy sources (VRES) supply. Next to their variable nature, VRES is also inherently difficult to predict and this uncertainty may create profitable arbitrage trading strategies between sequential short-term markets. As the focus of METIS on a single spot market does not allow to incorporate such benefits, the results on the economic value of flexibility technologies should be considered as a lower bound, targeting flexibility needs arising from variability in production and supply rather than uncertainty in production and supply.

### Results

Flexibility requirements estimates in this work are derived based upon the residual load curve. The residual load curve is defined as the load served by technologies that can be dispatched flexibly, and is derived by subtracting the must-run and VRES generation from the realised demand curve. The residual load curve as such indicates which part of the demand needs to be met by flexible technologies (e.g. thermal generation units, hydro-power, interconnectors, storage etc.). We define  $FR^T$  as the yearly flexibility requirements with a granularity of time  $T$  by:

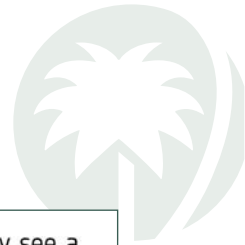
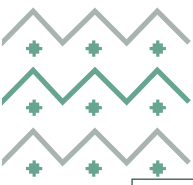
$$FR^T = \sum_T \frac{1}{2} \sum_t |RL_t - \overline{RL}_t| \quad (1)$$

Where  $RL_t$  represents the residual load at time step  $t$ . Note that by definition, positive and negative flexibility requirements have to be equal. In this report, we focus on the absolute value of these flexibility requirements, taking half of the sum of both the positive and negative requirements. In other words, the sum of the positive differences over  $T$  between the residual load at  $t$  and the average residual load over  $T$  renders the flexibility requirements over  $T$ . We sum over all timescales  $T$  in a year to compare flexibility requirements with a different timescale  $T$  over one specific year.

Comparing the flexibility requirements across the three different timescales, we observe daily flexibility requirements to be the largest across the EU in 2030 with 287.7 TWh compared to 258.4 TWh on a weekly and 172.7 TWh on a monthly basis. In 2050, these flexibility requirements respectively increase on EU level to 919 TWh, 775.4 TWh and 494.4 TWh. In 2030, the Netherlands, with the largest relative MS share of wind to total demand in 2030, experiences the highest flexibility requirements relative to the total demand on all three timescales. In 2050, the picture is more dispersed, with next to the Netherlands, also Ireland and the Baltic States ranking high in terms the relation between flexibility requirements to total demand. We find however that the relative share of flexibility requirements for these countries may only increase slightly or even decrease between





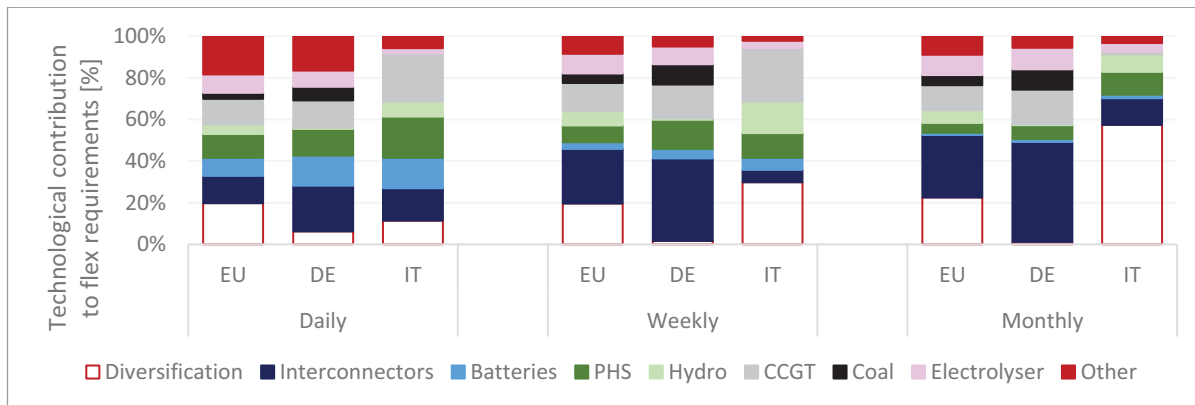


2030 and 2050, while countries with a relative low share of flexibility requirements to total demand may see a more pronounced increase of that share moving towards 2050. Comparing the relative share of flexibility requirements to total demand to 2021 however does present pronounced increases, for both 2030 and 2050, across all timescales and for all Member States.

Next, we study the effect of VRES on flexibility requirements by increasing the share of VRES across the entire EU under ceteris paribus conditions. While such a high degree of control allows us to isolate the effect of VRES on flexibility requirements, one has to bear in mind that in reality this would distort the equilibrium in energy systems, resulting in an adaptive shift in underlying production technologies. We find that for the EU, with more VRES installed, the flexibility requirements increase. The increasing trend seems to accelerate for the daily and weekly flexibility requirements, with the inflection point for the EU around a VRES capacity share of 74% to total installed capacity, related to the inability of the 2030 power system to cope with the sharp increase of VRES of the following decades. We find an increasing share of installed solar PV capacity to correlate only with an increase in daily flexibility requirements, while the increase in installed wind capacity correlates only with weekly and monthly flexibility requirements.

We conclude by studying which technologies contribute to addressing the flexibility requirements. These technologies include dispatchable units, which are able to adjust generation flexibly according the residual demand, but also storage, interconnectors and demand-side management technologies may contribute in relieving the flexibility needs. Figure 1 shows the contributions of the main flexible technologies to the flexibility requirements in the context of our study for the EU, Germany and Italy. We find that interconnectors are one of the main sources offering flexibility, mainly as imports and exports vary according to MS specific flexibility needs. Their relative contribution increases for the EU from 15% for the daily requirements to 33% for the monthly requirements, signalling the important role of interconnectors in dealing with longer duration flexibility needs in the residual load curve. Short-term storage technologies like batteries also offer a considerable amount to relieve the daily flexibility requirements, but much less so for the weekly and monthly requirements. Pumped hydro storage (PHS) follows a similar pattern, although their role in addressing flexibility needs is an important factor across all three timescales. From the thermal generation units, Combined Cycle Gas Turbines (CCGT) contribute a significant amount in addressing the daily and weekly flexibility needs. Finally, electrolyzers provide a considerable contribution to the flexibility requirements on EU level, consistently addressing 10% of the flexibility requirements across all timescales. The combined role of other technologies, like for example OCGT, oil and biomass, only seems to be of certain relevance in addressing the daily flexibility requirements.

**Figure 1:** Technological contribution to flexibility requirements in the EU, Germany and Italy, 2030.

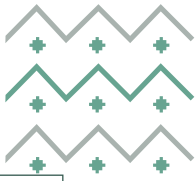


## Conclusions

In this study, we address the flexibility requirements and storage solutions by simulating operations in a 2030 and 2050 EU energy system with the METIS energy model. We find that compared to today's levels, flexibility requirements will increase significantly in all EU Member States. The numbers present considerable flexibility requirements, indicating the need for both short-term and long-term flexibility solutions in future European power systems. We further observe that the market share of VRES directly affects the share of flexibility requirements to total demand, while the type of VRES affects on which time duration energy system flexibility is needed. Efficiently integrating both sources of renewable energy sources in the power system thus requires an adequate evaluation of necessary related short-term or long-term flexibility solutions. Finally, the results show that multiple technologies are needed to address the flexibility needs at different time scales, showing that while new storage solutions become increasingly important, conventional assets may also remain important in addressing flexibility needs.







## *Saudi Arabia Net-Zero emissions by 2060: Transformation of the electricity sector*

Puneet Kamboj, King Abdullah Petroleum Studies and Research Center, +966112903168, [puneet.kamboj@kapsarc.org](mailto:puneet.kamboj@kapsarc.org)  
Mohamad Hejazi, King Abdullah Petroleum Studies and Research Center, [mohamad.hejazi@kapsarc.org](mailto:mohamad.hejazi@kapsarc.org)  
Khalid Alhadhrami, King Abdullah Petroleum Studies and Research Center, [khalid.hadharami@kapsarc.org](mailto:khalid.hadharami@kapsarc.org)  
Gokul Iyer, Pacific Northwest National Laboratory, [gokul.iyer@pnnl.gov](mailto:gokul.iyer@pnnl.gov)  
Page Kyle, Pacific Northwest National Laboratory, [pkyle@pnnl.gov](mailto:pkyle@pnnl.gov)  
Silvia Regina Santos Da Silva, Geog Mason University, [ssantosd@gmu.edu](mailto:ssantosd@gmu.edu)

### Overview

In the lead of COP 26, Saudi Arabia announced achieving net-zero emissions by 2060 under the umbrella of the Saudi Green Initiative. To achieve this target, the share of electricity in the final energy mix of the Kingdom will have to increase irrespective of the pathway chosen. The fuel mix of Saudi Arabia's electricity generation comprises conventional fuels (oil and natural gas) and a negligible share of renewable energy. Hence, decarbonizing the electricity generation mix of Saudi Arabia is of utmost importance and will require a complete transformation from the current fuel mix. This study explores various electricity generation technology options relevant to the Kingdom, including carbon capture for achieving net-zero emissions by 2060. We also look at the required investment for each technology option in the long term.

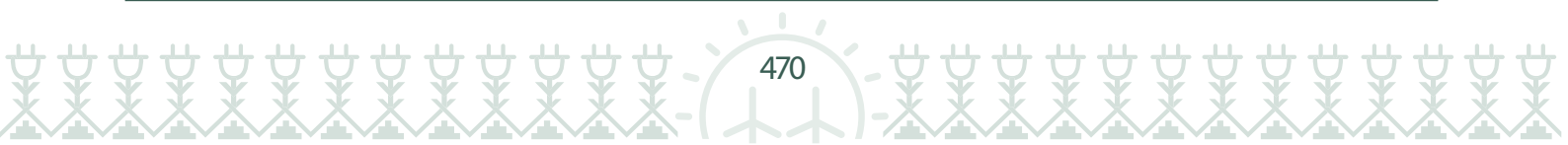
### Methods

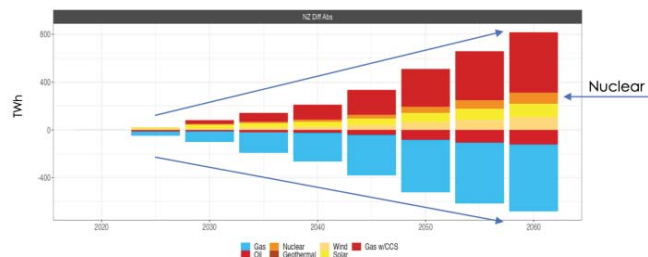
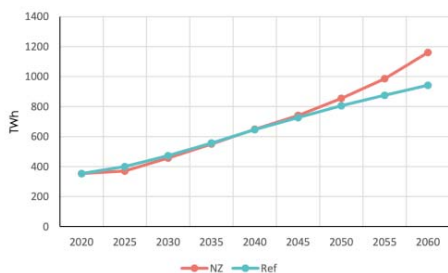
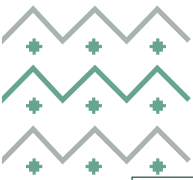
For this study, we use a modified version of the Global Change Analysis Model (GCAM v6.0), where we have separated the Kingdom of Saudi Arabia (KSA) as a separate energy-economy region, i.e., GCAM-KSA includes 33 energy-economy regions (32 original regions plus KSA). Our scenarios are built on the emission scenarios developed by Ou et al. (2021). More specifically, we focus on two emission scenarios that reflect alternative pathways of climate policy regimes and their associated global GHG emissions. The reference scenario (green line in Figure 1) reflects a no climate policies world (i.e., a counterfactual scenario). The NZE-2060 scenario (red line in Figure 1) assumes that KSA will achieve carbon neutrality in 2060. For the rest of the world, we assume that the remaining 32 regions will achieve their updated NDCs by 2030, their NZE pledges if announced by their target year. For regions without NZE pledges, an annual rate of improvement in CO<sub>2</sub> emissions per unit of GDP is assumed to be in line with a 2 °C world. In the case of the Kingdom, we show that an NZE-2060 scenario requires deploying various technology options for the power sector, such as solar, wind, geothermal, nuclear, and gas, with carbon capture.

### Results

Our initial results show that by 2060 more electricity generation will be required in the net-zero scenario compared to the reference. Saudi Arabia's power sector will completely transform with a diversified fuel mix to reach net-zero emissions by 2060. Along with a significant share of renewable energy sources, electricity generation by natural gas with carbon capture will be the most critical technology. Nuclear electricity generation will also find its way into the fuel mix and play a vital role in the Kingdom's decarbonization of the power sector.

Figure 1 (LHS) Electricity generation in the Kingdom of Saudi Arabia for a reference and a net-zero scenario; (RHS) the absolute fuel-wise generation difference in the net-zero scenario w.r.t. the reference scenario





## Conclusions

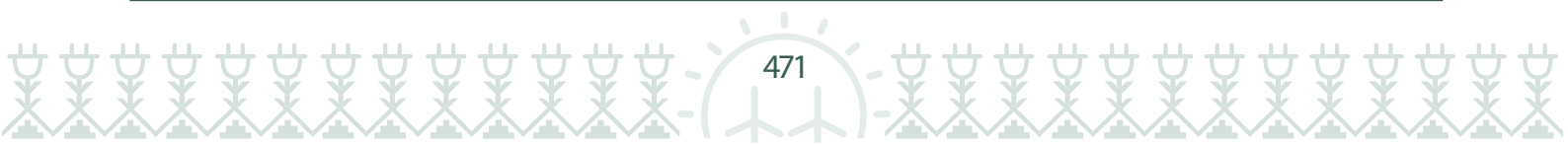
Our initial key takeaway is that in addition to electricity generation through solar and wind, gas generation with carbon capture will be the critical technology for Saudi Arabia to reach net-zero emissions from the power sector. Also, nuclear generation will find its way into the fuel mix for electricity generation.

## References

Ou et al., 2021. Can updated climate pledges limit warming well below 2°C? SCIENCE, 374, 6568, 693-695, DOI: 10.1126/science.abl8976.



Energy Modeling





## ***EMISSION TRADING OR LOWER ENERGY PRICES? RE-ASSESSING THE IMPACT OF THE GREENHOUSE GAS INITIATIVE ON THE ENERGY TRANSITION***

Daniel Gatscher, Technical University of Munich, Center for Energy Markets, +49 163 6654716, daniel.gatscher@tum.de  
Svetlana A. Ikonnikova, Technical University of Munich, +49 89 289 28820, svetlana.ikonnikova@tum.de

### **Overview**

Historically, the U.S. federal government leaves most of the decisions related to the climate agenda and carbon goals to the states. Thus, instead of relying on a country-level emission trading system (ETS), as the EU does with its ETS, the states are free to set their own goals and policies to support them. A notable exception to the individual approach has been a cooperative effort to implement the Regional Greenhouse Gas Initiative (RGGI) by several Eastern States of the U.S.. Announced as “cap-and-invest” program, RGGI has been set up to incentivize the switching to clean energy. With individual CO<sub>2</sub> budgets, the eleven participating states attempt to limit their emissions from power generation.

A decade after the introduction of the RGGI, data gave rise to an increasing number of studies assessing its efficiency. The common approach has been to compare the CO<sub>2</sub> emissions and fossil fuel usage between RGGI and non-RGGI states. While studies agree that RGGI serves its purpose, several issues have been raised. First, the limitations in the ability to account for the “shale revolution”: the growth in the natural gas supply and the sharp decline in the natural gas prices have coincided in time with the introduction of RGGI raising a question on to which extent the observed effect is induced by RGGI (Yan, 2021). Second, it was suggested that RGGI may have caused “carbon leakage” with the carbon intensive production outsourced to non-RGGI states affecting the observed CO<sub>2</sub> gap (Lee and Melstrom, 2018).

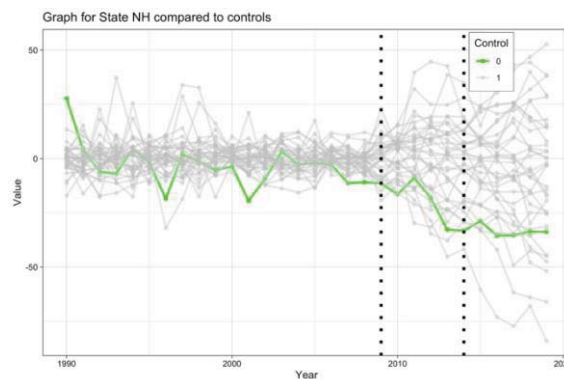
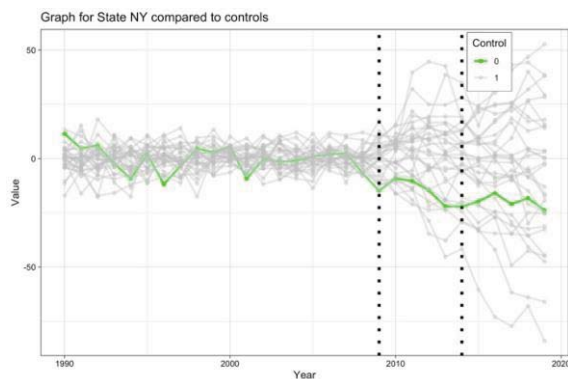
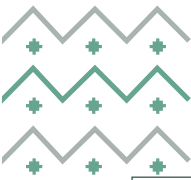
### **Methods**

The aim of our study is to address the raised issues. We develop a procedure enhancing the synthetic control method previously applied by Kim and Kim (2016) for RGGI analysis (Abadie and Gardeazabal, 2003). We implement the procedure to re-evaluate the previous results and report the changes. Considering the impact of the shale supply, we turn to the statistics on the production and import of unconventional natural gas by the states adjacent and remote from the RGGI, paying special attention to the growth of the Marcellus shale play located next to the RGGI states in the north-east of the U.S. and remote production in Texas and Louisiana. We build the counterfactuals for each RGGI-participating state testing the robustness of the previous results by including other the states from the Appalachian region, which may experience carbon leakage and the natural gas supply shock. We analyze the differences with those states using a different donor pool.

### **Results**

Our results imply that while the RGGI system indeed helped to reduce the CO<sub>2</sub> intensity of electricity production, in part the fuel shift should be attributed, as previously suspected, to the availability of cheap shale gas. We complement our analysis by computing the elasticity of interfuel substitution and its evolution over time for the different regions and find that states in the Marcellus play region exhibit a higher elasticity of substitution for coal and gas when compared to the remainder of the US states. Finally, we use the synthetic control and the elasticity model to project the response of Pennsylvania to joining the RGGI.



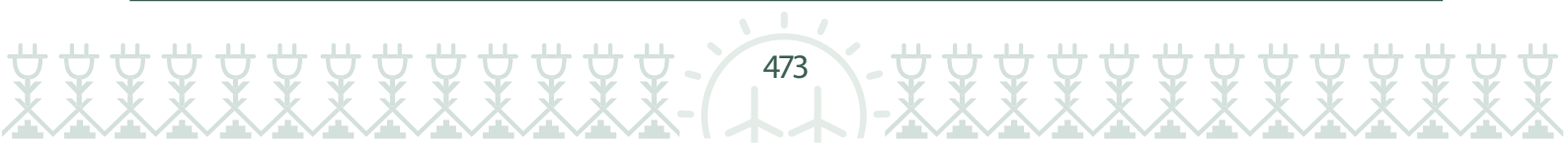


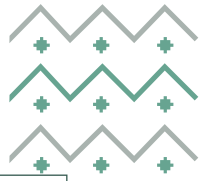
## Conclusions

In conclusion, we find that the implementation of the ETS by the RGGI, accompanied by the “shale revolution” are an ideal case for the application of the synthetic control method. Existing studies have not investigated the effect of coincidence of the two events. Thus, we suggest a new framework to quantify and separate the individual “treatment” effects. Using US state-level data, we create the counterfactuals in order to identify the regional extent of the effects and differentiate them. Still evolving, the methodology on the novel the synthetic control approach is finding its way into different branches of economics. Our study therefore calls for further investigation of energy related questions that take into account current developments in this method.

## References

- Abadie, A., Gardeazabal, J., 2003. The Economic Costs of Conflict: A Case Study of the Basque Country. *American Economic Review* 93, 113–132. <https://doi.org/10.1257/000282803321455188>
- Kim, M.-K., Kim, T., 2016. Estimating impact of regional greenhouse gas initiative on coal to gas switching using synthetic control methods. *Energy Economics* 59, 328–335. <https://doi.org/10.1016/j.eneco.2016.08.019>
- Lee, K., Melstrom, R.T., 2018. Evidence of increased electricity influx following the regional greenhouse gas initiative. *Energy Economics* 76, 127–135. <https://doi.org/10.1016/j.eneco.2018.10.003>
- Yan, J., 2021. The impact of climate policy on fossil fuel consumption: Evidence from the Regional Greenhouse Gas Initiative (RGGI). *Energy Economics* 100, 105333. <https://doi.org/10.1016/j.eneco.2021.105333>





## Long-term assessment of CSP entry into Saudi Arabia's power system using PLEXOS

Khalid Alhadhrami, KAPSARC, +966559120107, Khalid.hadhrami@KAPSARC.org  
Ahmed Albalawi, KAPSARC, +966509716252, Ahmed.balawi@KAPSARC.org

### Overview

Recently, renewables are being developed in the context of reducing CO<sub>2</sub> emissions and climate change. Most renewable energy resources are intermittent due to their weather dependency. They need energy storage to be dispatchable. Concentrated solar power (CSP) has thermal storage inherent in the system that makes it dispatchable. CSP is a technology that generates power by concentrating solar energy onto a receiver and then using the heat in a power generation cycle. CSP has potential in regions with high direct nominal irradiance, but its capacity deployment is still limited due to its high capital expenditure (CAPEX). However, future energy mixes will likely include different types of renewable energy resources including CSP to replace fossil fuels and reduce emissions. The inherent thermal storage in CSP systems make their valuation a bit more challenging in energy expansion models. This study will model and analyze the CSP in long term expansion modeling of the Saudi power system to assess its potential role in the energy mix to achieve Saudi Arabia's 50% renewable energy target by 2030.

### Methods

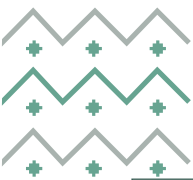
Energy system analysis is conducted using the Energy Exemplar power systems software, PLEXOS, to simulate the long-term energy expansion. CSP yield analysis were done using the System Advisor Model (SAM). The output of SAM estimates for CSP plant productivity using hourly historical weather data for Saudi Arabia are then fed as an input data in PLEXOS (Narimani et al, 2017; and Denholm et al, 2014). The performance data in addition to financial assumptions form the CSP candidates' inputs in PLEXOS. The Saudi power system is modeled by dividing the kingdom load into six regions and taking the base year as 2018 (Elshurafa et al, 2021). We conduct a long-term study for the entry of CSP into Saudi Arabia's power system until 2030. The renewable energy options in our analysis are PV solar, CSP, and wind power. Also, we included battery energy storage candidates as options. Two scenarios were considered on the modelling, one with CSP candidates, and another one without. Then we analyzed what the generation mix would be in 2030 in the case of 50% renewable energy and 50% natural gas with the retirement of fossil fuels generators.

### Results

The results are focusing on the comparison between two scenarios; one is the Saudi power system with CSP candidates and another scenario without CSP candidates. The resulting two different technology mix scenarios for the 50% target by 2030 and the findings are compared and contrasted based on different criterias. First, the cost differences for both scenarios to measure the effect of the CSP entry on the long term planning cost. We compare the Levelized cost of energy (LCOE) between both scenarios in terms of the mix of technologies used in each one (e.g., the number of installed batteries in each scenario and the other technologies). Given the high Capital costs of CSP, the economic optimization of the system did not build any units of it. Therefore, a constraint was added to include at least 10% of CSP in the total installed capacity by 2030 as shown in Figure 1. This percentage will allow us to study the effect of the presence of CSPs on the acceleration of reaching the 50% renewables goal by 2030 and the effect of CSPs on accelerating the retirement of fossil fuel-based generators.

Finally, based on the technologies mix, we compare the Loss of Load Probability (LOLP) to evaluate the system reliability for the scenarios by including the forced outage rate for each renewable energy technology. The goal here





is to measure the impact of CSP's entry into the Saudi power system and its contribution to reaching 50% renewable energy and 50% natural gas generation mix by 2030.

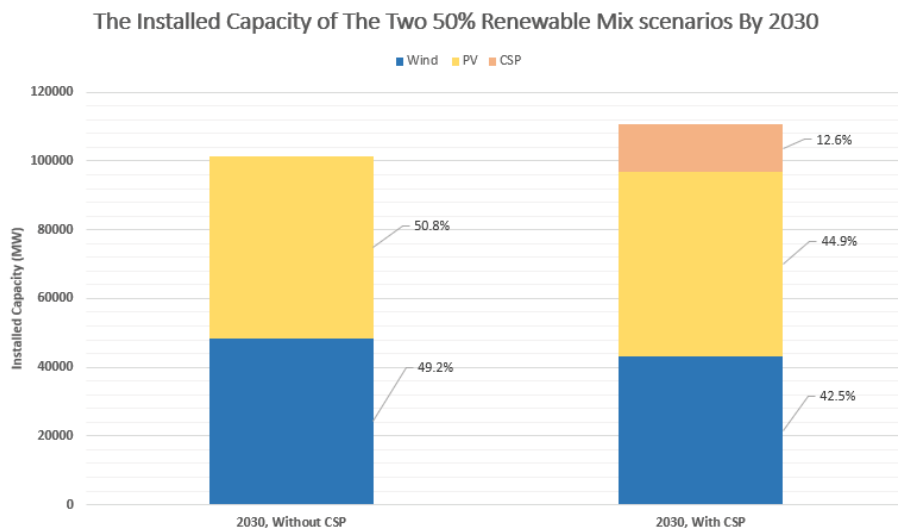


Figure 1: The installed capacity results for the two 50% renewables mix scenarios by 2030

## Conclusions

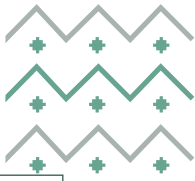
The entry of new renewable energy technologies into the power system is expected in the coming years, and studying the impact of these technologies can make reaching the Kingdom's power sector goals faster and more reliably. Through our study, we measured the impact of the CSP entry into the power system to have a better understanding of its contribution to the system cost, reliability, and acceleration of reaching the 50% renewables goal by 2030.

In addition to measuring the impact of the CSP's entry into Saudi Arabia's power system, the costs of the technology are still high compared to other renewable energy resources. A significant cost reductions and increased deployment is needed to bring the cost down. Alternatively, the power system benefits that CSP can bring may offset its costs and make a valuable resource in the energy mix. The findings of this study can be used to compare CSP with other technologies in the future to assess how they may affect the renewable energy generation mix in Saudi Arabia.

## References

- Elshurafa, Amro M., Hatem Alatawi, Salaheddine Soummane, and Frank A. Felder. "Assessing effects of renewable deployment on emissions in the Saudi power sector until 2040 using integer optimization." *The Electricity Journal* 34, no. 6 (2021): 106973.
- Elshurafa, Amro M. "The value of storage in electricity generation: A qualitative and quantitative review." *Journal of Energy Storage* 32 (2020): 101872.
- Diakov, Victor, Wesley Cole, Patrick Sullivan, Gregory Brinkman, and Robert Margolis. *Improving Power System Modeling. A Tool to Link Capacity Expansion and Production Cost Models*. No. NREL/TP-6A20-64905. National Renewable Energy Lab.(NREL), Golden, CO (United States), 2015.
- Implementation CSP in PLEXOS. Everything about solar energy 2020, August 10, 2015. <http://energyprofessionalsymposium.com/?p=1922>.
- Denholm, P., Y-H. Wan, M. Hummon, and M. Mehos. "The value of CSP with thermal energy storage in the western United States." *Energy Procedia* 49 (2014): 1622-1631.
- Narimani, A., A. Abeygunawardana, B. Khoo, L. Maistry, G. F. Ledwich, G. R. Walker, and G. Nourbakhsh. "Energy and ancillary services value of CSP with thermal energy storage in the Australian national electricity market." In 2017 IEEE Power & Energy Society General Meeting, pp. 1-5. IEEE, 2017.





## Short-Term System Marginal Price Forecasting Using 2-Stage Variable Selection Approach

[SangWoo Shim, Konkuk University, +82-10-2368-0294, tkddn349@konkuk.ac.kr]  
 [DaHan Lee, Konkuk University, +82-2-458-4778, timeflaw@konkuk.ac.kr]  
 [JaeHyung Roh, Konkuk University, +82-2-450-3934, jhroh@konkuk.ac.kr]  
 [Jong-Bae Park, Konkuk University, +82-2-450-3483, jbaepark@konkuk.ac.kr]

### Overview

The Korean electricity market structure is a CBP(Cost Based Pool). Due to this type of electricity market, the cost of a Genete unit is set by KPX(Korea Power Exchange). Generation companies have to bid only for capacity when they participate in the electricity market. Therefore, information on SMP(System Marginal Price) may seem unnecessary. Still, SMP is an important component of the electricity market[1]. Suppose the Korean electricity market changes to the PBP(Price-Based Pool) market. In that case, forecasted SMP will contribute to establishing strategies for price bidding by generators.

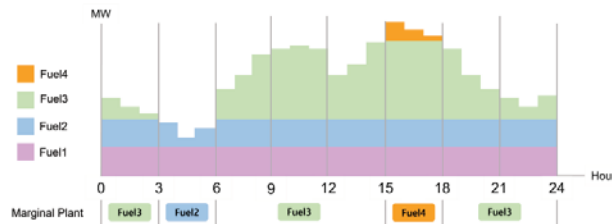


Figure 1. SMP determination

KPX(Korea Power Exchange) forecasts the load and receives offers for capacity from generation companies one day ahead. It then determines the market price by producing a PSS(Price Setting Schedule) set up by a program that minimizes the total production cost of generating units. In the PSS, SMP for each hour is calculated to meet the demand for each hour. The marginal price of the most expensive generating unit in the PSS is the SMP, and that unit becomes the marginal plant(the last plant in merit order)[2].

Many studies in forecasting SMP have included predictions using rough set theory and ANN(Artificial Neural Network) and long-term forecasting using a periodic pattern of SMP decomposition and oil price[3-4]. This paper suggests a 2-Stage method that predicts SMP at the second stage using load from the first stage. The electricity demand data is important to forecast SMP. Therefore, predicting SMP through load forecasting is helpful for operators with sparsity information.

To forecast SMP, models are used, such as Support Vector Machine(SVM), Random Forest, XGBoost(eXtream Gradient Boost), and LSTM(Long Short-Term Memory). Because they are still often used nowadays and have each strength. SVM model has less impact on error data, XGBoost and Random Forest do not overfit well, and LSTM is proper for time series forecasting. The algorithm trains data from the first in January to the before test day using forecasting models and calculates predicted SMPs. The prediction performance based on the ensemble of the above models is expressed through MAPE(Mean Absolute Percentage Error), nRMSE(normalized Mean Absolute Error), nMAE(normalized Mean Absolute Error) in the Result sector, and future research plans to develop the paper are written in the Conclusions.

### Methods

Predicting algorithm for SMPs using the 2-Stage method is illustrated in Figure 2. At the load forecasting stage, weather data, including temperature and amount of sunlight, historical demand of a day before, and time information(i.e., hour, month, and day of the week) are used. Weather data provided by the Korea Meteorological Administration[5] are classified by region. Therefore, in this paper, national weather data were constructed by weighting based on the amount of regional load consumed[6]. One of the above forecasting models is used for predicting load and the last three forecasting models repeat the same process.

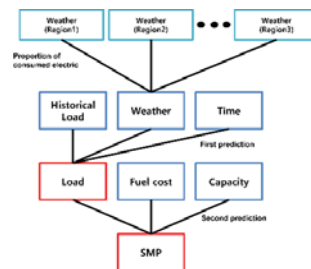


Figure 2. 2-Stage method

Before load predicting, important variables need to be selected to increase the performance. The algorithm uses SHAP(Shapley Additional exPlanations) method and the Pearson Correlation Coefficient method. The SHAP method measures the importance of variables, and the Pearson Correlation Coefficient method measures linearity between variables.

The variables with high linearity in prediction need not be used together and decrease forecasting performance, so this paper removed them.

The SHAP method is an artificial intelligence method that explains the relationship between the input variable and the result value of the forecasting model through Shapley Value[7]. The importance of variables for forecasting load is expressed in Figure 3. The Shapley Value is obtained according to the change due to the addition or removal of the corresponding variable from the combination of various variables.

The Pearson Correlation Coefficient indicates the degree of linear relevance between two variables and has a value between -1 and 1. The more significant the absolute value of the Pearson correlation coefficient, the more significant the correlation, and the sign indicates the direction of the correlation. When the Pearson correlation coefficient is expressed in Figure 4, it confirms that all variables have a low correlation, except that the correlation between the month variable and the temperature variable is slightly higher at 0.67.

At the SMP forecasting stage, SMPs are calculated using load forecasting results, fuel costs of each generator such as nuclear, coal, natural gas, oil, and the capacity of each fuel resource. This paper used the algorithm to conduct SMP predictions quarterly for the season in 2021, and testing was born three days after the training. All models were applied to each stage prediction. Thus experiments were conducted with a total of sixteen ensemble models.

## Results

The XGBoost-Random Forest ensemble method makes the best performance for forecasting SMP. When forecasting SMP, the Random Forest model's case using load data from XGBoost performs best. That ensemble method performed about 1% better in MAPE than other ensembles, and compared to other studies using Artificial Neural networks, the performance was measured slightly better. And in general, XGBoost performs the best for forecasting load, and Random Forest performs the best for forecasting SMP. In demand forecasting, six variables were selected through the SHAP method for sixteen weather, time, and historical demand variables. The prediction performance was increased by about 0.5% in MAPE by removing unnecessary variables.

## Conclusions

After classifying dates such as weekends, weekdays, and special days according to load patterns, the forecasting performance will be measured, and the recently presented forecasting model will be used for that algorithm. Suppose these algorithms include long-term forecastings such as demand, fuel cost, and capacity. In that case, it will be possible to establish a long-term SMP outlook, contributing to the generator installation, capacity planning, or investment.

## References

- [1] J. H. Kong et al. (2018), Development of ESS Scheduling Algorithm to Maximize the Potential Profitability of PV Generation Supplier in South Korea, *Journal of Electrical Engineering & Technology*, 13(6), 2227-2235.
- [2] Korea Power Exchange, "<https://new.kpx.or.kr/menu.es?mid=a10401040000>".
- [3] J. K. Lee, J. B. Park, J. R. Shin, & K. Y. Lee (2005), A system marginal price forecasting based on an artificial neural network adapted with rough set theory, *IEEE Power Engineering Society General Meeting*, vol. 1, 528-533.
- [4] B. R. Oh, D. -H. Lee, & D. H. Lee (2022), Oil-Price Based Long-Term Hourly System Marginal Electricity Price Scenario Generation, in *IEEE Access*, vol. 10, 25051-25061.
- [5] Korea Meteorological Administration, "<http://www.weather.go.kr/>".
- [6] D. H. Kim, H. J. Jo, M. S. Kim, J. H. Roh, & J. B. Park (2019), Short-term load forecasting based on deep learning model, *The Transactions of The Korean Institute of Electrical Engineers*, 68(9), 1094-1099.
- [7] Eyal Winter (2002), *Handbook of Game Theory with Economic Applications*, vol. 3, 2025-2054.

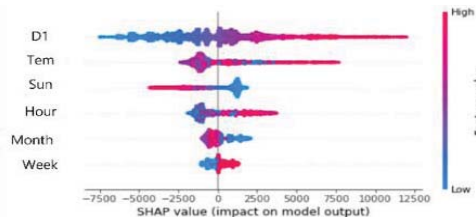


Figure 3. SHAP value of the input variable

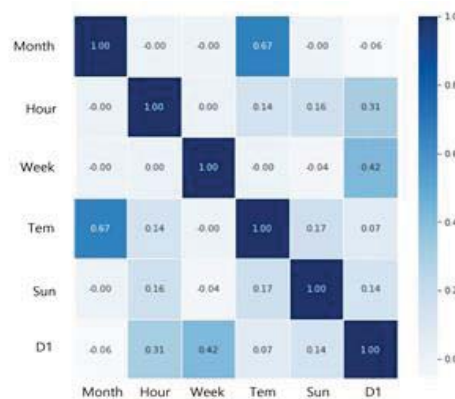
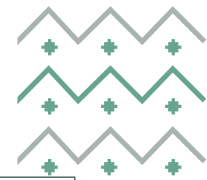


Figure 4. Pearson Correlation Coefficient for input variables



## Six regions one sun one grid

Xiaoming Kan, Department of Space, Earth and Environment, Chalmers University of Technology, 41296 Gothenburg, Sweden, kanx@chalmers.se

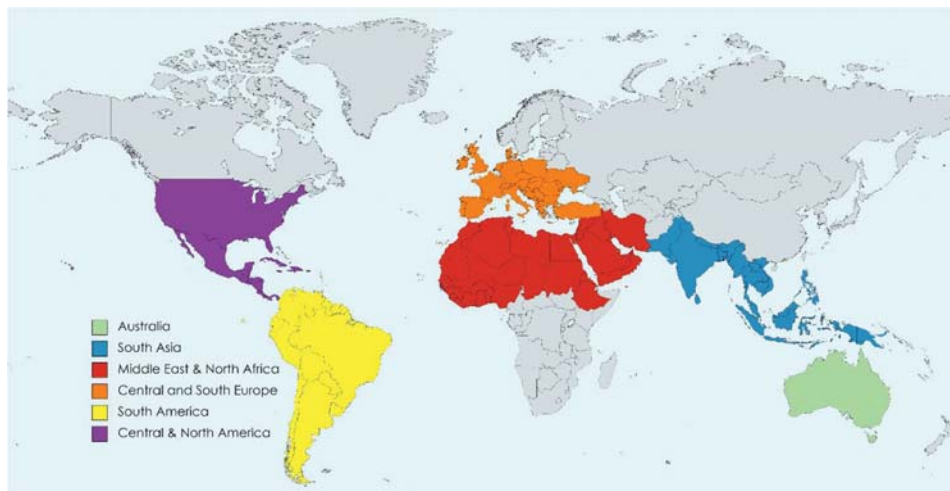
### Overview

The past decade has witnessed sustained cost reduction and rapid diffusion of renewable energy technologies such as wind and solar photovoltaic (PV) (IRENA, 2022). Though solar energy is the most abundant energy resource on earth, it is available only during the daytime and is dependent on the weather condition (Parida et al., 2011). However, the sun never sets from a global perspective, and half of the earth is bathed in sunshine at any given time. An idea to utilize the never-set solar radiation is to build an inter-continental transmission network to connect different time zones and trade renewable energy across borders. This initiative is known as One Sun One World One Grid Declaration (OSOWOG), which was jointly released by the Prime Ministers of India and the UK at the COP26 Climate Meet in Glasgow. One potential benefit of this initiative is to use energy at night in one part of the world generated from solar on the other side of the world where it is daytime. This might reduce storage and back up generation capacity needs at night, thus, enhancing the viability of solar projects.

There are a handful of studies investigating the interconnection of two or more continents for the renewable future. (Reichenberg et al., 2022) investigated the cost benefit of a Eurasian interconnection between China, Mid-Asia and Europe and showed that a super grid option decreases total system cost by up to 5%, compared to continental grid integration. (Breyer et al., 2020) evaluated the effect of integrating nine "major regions" of the world in a potential global grid and found that the cost benefit of doing so is 2%. (Bogdanov et al., 2016) suggested a cost reduction of 1.3% by connecting Europe, Eurasia, Middle East and North Africa. These studies all assume a homogeneous cost of capital across the world without considering the additional investment risk for less developed and less stable counties. Apart from the resource endowment, the economics of extracting solar resource also depend on the socio-economic, man-made reality. The cost to finance any economic endeavor, and especially so projects characterized by high upfront investment costs like solar, is highly dependent on cost of capital which varies between countries.

### Methods

Here we assess the techno-economic cost benefits of connecting different time zones for the future renewable energy system. We also take into account the heterogeneity of cost of capital between countries, as argued by (Egli et al., 2019), the practical importance of which is emphasized in (Muttitt et al., 2021). Technically, we use a techno-economic cost optimization model for capacity expansion with hourly time resolution (Reichenberg et al., 2022) to model six interconnected sunny regions: Australia, South Asia, Middle East and North Africa, Central and South Europe, South America, Central and North America (see Figure 1). Specifically, we evaluate the inter-continental supergrid option for a renewable energy system in 2050 under different assumptions for technology costs; land availability for solar and wind installations; carbon cap; uncertainty of future electricity demand and availability of nuclear power.



**Figure 1** The modeled interconnected regions. Each region shown in this map is divided into several small subregions and these subregions are interconnected with transmission network.







## Results

The cost for the entire energy system is evaluated with and without the inter-continental supergrid option. We first calculate the system cost based on a uniform cost of capital 5%. The supergrid reduces the system cost by 5% compared to the case in which the six regions are modeled in isolation. Wind and solar together dominate the generation capacity mix with the total share reaching 89%. The supergrid option favors more onshore wind power with the share increasing from 41% in the isolated case to 47% in the inter-continental case. By comparison, the share of solar PV experiences a slight decrease from 41% to 39% due to supergrid. We also investigate the benefit of connecting only neighboring regions. The largest cost benefit is observed for connecting Middle East and North Africa (MENA) to Central and South Europe, with the system cost reduction reaching 7%. Connecting the Americas reduces the system cost by 3%, while connecting Australia to South Asia only reduces the system cost by 1%. The relatively large cost reduction for connecting MENA to Europe is likely due to tapping the abundant renewable resources from MENA to meet the high energy demand in Europe.

To better evaluate the impact of trade between different time zones on the day-night smoothing of solar power output, we investigate one scenario where Europe is not included in the global electricity network. In this case, the regions included in the inter-continental supergrid span over 17 time zones, covering sunny countries from Australia to the US. The cost reduction due to supergrid is 2.8% which is lower than the cost reduction when Europe is integrated.

When considering the country-specific cost of capital, the inter-continental supergrid only reduces the system cost by 2.3%, which is not surprising. Some countries endowed with good renewable resources are enduring political and social unrest, where the cost of capital is very high, e.g., Venezuela and Sudan. The heterogeneity in investment risks highly influence the cost of developing renewable energy (Kan et al., 2022). One typical example is the region MENA. For the case of uniform cost of capital, when connecting MENA to Europe, Europe relies heavily on importing renewable energy from MENA. There are obvious surplus generation in African countries with good renewable resources. By comparison, the energy export from MENA to Europe is evidently lower when applying the country-specific cost of capital. Correspondingly, the generation in North Africa shifts to countries with relatively low cost of capital, e.g., Egypt. As for inter-continental connection, the transmission capacity between MENA and Europe in the case of country-specific cost of capital is only 38% of the capacity in the case of uniform cost of capital. Given this, using North Africa to tap solar resources, as previously suggested by (Van Wijk and Wouters, 2021), is perhaps not as economically attractive as the solar radiation data alone might suggest.

## Conclusions

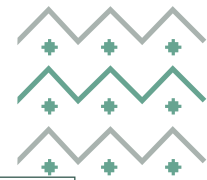
We evaluate the cost-effectiveness of an inter-continental supergrid connecting Australia to the US for the renewable future. Our results show that the supergrid reduces the system cost by 2.3% with country-specific cost of capital, while the system cost is reduced by 5% for an optimistic future where countries experiencing political and social unrest evolve socio-politically such that their costs of capital decline over time. The globally heterogeneous cost of capital highly influence the cost of providing renewable energy in a future renewables-based energy system.

## Reference

- BOGDANOV, D., KOSKINEN, O., AGHAHOSSEINI, A. & BREYER, C. Integrated renewable energy based power system for Europe, Eurasia and MENA regions. 2016 International Energy and Sustainability Conference (IESC), 2016. IEEE, 1-9.
- BREYER, C., BOGDANOV, D., AGHAHOSSEINI, A., GULAGI, A. & FASIHI, M. 2020. On the techno-economic benefits of a global energy interconnection. *Economics of Energy & Environmental Policy*, 9, 83-102.
- EGLI, F., STEFFEN, B. & SCHMIDT, T. S. 2019. Bias in energy system models with uniform cost of capital assumption. *Nature communications*, 10, 1-3.
- IRENA 2022. Renewable Power Generation Costs in 2021. Abu Dhabi: International Renewable Energy Agency.
- KAN, X., REICHENBERG, L., HEDENUS, F. & DANIELS, D. 2022. Global renewable LCOE--including socio-economic factors in assessments of resource potential. *arXiv preprint arXiv:2202.02257*.
- MUTTITT, G., SHARMA, S., MOSTAFA, M., KÜHNE, K., DOUKAS, A., GERASIMCHUK, I. & ROTH, J. 2021. Step Off the Gas:: International public finance, natural gas, and clean alternatives in the Global South. JSTOR.
- PARIDA, B., INIYAN, S. & GOIC, R. 2011. A review of solar photovoltaic technologies. *Renewable and sustainable energy reviews*, 15, 1625-1636.
- REICHENBERG, L., HEDENUS, F., MATTSSON, N. & VERENDEL, V. 2022. Deep decarbonization and the supergrid--Prospects for electricity transmission between Europe and China. *Energy*, 239, 122335.
- VAN WIJK, A. & WOUTERS, F. 2021. Hydrogen--the bridge between Africa and Europe. *Shaping an inclusive energy transition*, 91-120.







## INTER-FUEL SUBSTITUTION IN INDUSTRIAL SECTOR OF SAUDI ARABIA

Muhammad Javid, KAPSARC, +966538300791, muhammad.javid@kapsarc.org  
 Fakhri Hasanov, KAPSARC, +966540900964, fakhri.hasanov@kapsarc.org  
 Abdulelah Darandary, KAPSARC, +966501912777, abdulelah.darandary@kapsarc.org

### Overview

Based on a variety of export-oriented industries including oil and gas, the Kingdom of Saudi Arabia has the largest industrial sector in the MENA region. Since the launch of the Vision 2030, the government of Saudi Arabia has successfully implemented enormous initiatives and structural reforms, including financial and administrative support to the industrial sector for economic transformation. These include a well-developed infrastructure, high-quality utilities and a well-established logistics network, enhancing local content, and the establishment of the SIDF (Saudi Industrial Development Fund) that has promoted industrialization. Another important initiative was the National Industrial Development and Logistics Program (NIDLP), which the Saudi Arabian government took in 2019 to achieve the goal of economic diversification towards sustainable growth by promoting a globally attractive investment environment in the country.

Industrial sector is the largest sector of Saudi Arabia's economy and has played a vital role not only in the strengthening of the economic growth but also in generating employment opportunities in the country. The industrial sector has experienced rapid growth over the last five decades. The industrial value added in Saudi Arabia increased sharply during 1970-2021. In 2021, industrial value added (at constant 2015US\$) was US\$278 billion, which is 3.5 times the level of the 1970s, and the corresponding growth rates were 5% over the same periods (WDI 2022). However, the fluctuation was observed in the share of the industrial sector in total GDP. The average share of industrial value added in GDP was 68% in the 1970s and it reduced to 53% in the 2020s (WDI 2022).

Total energy consumption in Saudi Arabia's industrial sector grew rapidly during the period 1990-2019, with an annual growth rate of 8.3%. The natural gas and heavy fuel oil (HFO) are the main fuels consumed by Saudi Arabia's industrial sector. Between 1990 and 2019, the average annual growth rate of natural gas was 10.5%, fuel oil 6.8%, and electricity was 14.2%. The industrial sector of Saudi Arabia accounted for about 50% (Alarenan et al. 2020) of total energy consumption. Based on the proposed economic diversification strategy in Saudi Vision 2030, it seems likely that Saudi Arabia's industrial sector will continue to grow rapidly for a long time, owing to the high demand for energy. Therefore, the industrial sector, as a major energy consumer, has a much stronger incentive to switch to alternative fuels.

An investigation of substitution between different energy sources in industrial sector of Saudi Arabia is important for at least two reasons; first, because of the opportunity cost of domestic oil consumption in the industrial sector, and second, from an environmental perspective. Because the consumption of different types of energy is associated with different levels of emissions. Substitution between fuels is an important topic of research as governments around the world seek to implement policies to reduce carbon emissions from certain type of fuels.

Because of its unique geographical and climatic location, Saudi Arabia has an impressive natural potential for solar and wind power, making the use of renewable energy sources economically attractive. In this regard, Saudi Arabia has initiated several projects to diversify the country's energy resources and improving its energy mix.

The potential for inter-fuel substitution between oil, gas, and electricity in Saudi Arabia's industrial sector is a worthy research topic in the context of economic and environmental importance, as well as renewable energy resources.

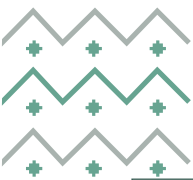
Reducing dependence on oil in industrial sector in favor of other energy sources has important implications for Saudi Arabia's economic growth, oil exports and environment.

### Methods

To estimate energy demand elasticities, the standard approach in the energy economic literature is use a trans-log cost function. In this study, we use a log linear trans-log production function which is a second order Taylor Series approximation to investigate the extent of inter-fuel substitution between natural gas, fuel oil, diesel oil, and electricity in the industrial sector of Saudi Arabia over the period 1990 and 2019. A trans-log production function, which describes the relationship between output and input from various productive factors, can be expressed in general function form as follows:

$$y = \beta_0 + \sum_i \beta_i x_i + \frac{1}{2} \sum_i \sum_j \beta_{ij} x_i x_j$$





Where,  $y$  is log of industrial value added,  $\beta_0$  represent the intercept,  $x_i$  and  $x_j$  represent inputs  $i$  and  $j$  respectively in natural logarithmic form.  $\beta_i$  and  $\beta_{ij}$  are technologically determined parameters. The fundamental assumption is that there exists a twice differentiable trans-log production function that relates industrial value added to capital, labor, and energy inputs (natural gas, fuel oil, diesel and electricity). According to Pavelescu (2011), the trans-log functional form allows one to avoid assumptions like perfect competition or perfect substitution among inputs. The presence of quadratic terms also allows for nonlinear relationships between the output and the inputs. These features make the trans-log production function attractive to researchers because it is more flexible than other functional forms. We have square terms of the independent variables and cross products of various input variables in the trans log function, so there is a possibility of multicollinearity between the independent variables. In order to avoid the possibility of multicollinearity among the independent variables, we employed the ridge regression approach for estimation following Smith et al. (2011). Based on ridge estimation, we have calculated the output elasticity and substitution of alternative energy inputs.

## Results

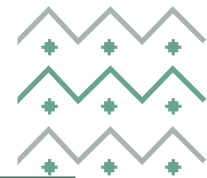
The estimation results show that the output elasticity for natural gas, diesel, fuel oil, and electricity are all positive, but the output elasticity of diesel and fuel oil has been inelastic over the period, while natural gas has been elastic in recent years. Output elasticity of electricity is elastic over the study period. The elasticities' ranking has remained constant over the estimated period. In Saudi Arabia's industrial sector, output elasticity of fuel oil is the most inelastic, followed by output elasticity diesel, natural gas, and electricity. The estimated output elasticity of diesel and fuel oil has remained relatively constant over time, while the output elasticity of natural gas and electricity has increased. The elasticity of substitution is greatest between diesel oil and electricity, then between electricity and fuel oil, and finally between electricity and natural gas. All substitution elasticities have remained constant over time, except for the elasticity of substitution between diesel and fuel, which has fluctuated over time.

## Conclusions

In this paper, a trans-log production function model is developed to investigate the elasticity of inter-fuel substitution between natural gas, diesel, fuel oil, and electricity in Saudi Arabia's industrial sector. To estimate the function's parameters, a ridge regression procedure is used. We find positive output elasticity for all energy inputs, indicating that there is an increasing return in the use of these energy inputs in the Saudi industrial sector over time. This finding supports the widely held belief that energy acts as a catalyst for growth.

The results show that the substitution possibilities between natural gas and electricity, diesel and electricity, and fuel oil and electricity are relatively higher. These findings highlight the potential for the Saudi industrial sector to switch away from greenhouse gas emitting fuels like fuel oil and diesel toward electricity. Given that the substitution elasticity of fuel oil-electricity and diesel-electricity is the greatest among those observed in this study. Therefore, these findings provide general insights and highlight the importance of policies that focus on renewable electricity installed capacity. Models for forecasting future energy demand in the industrial sector can use the inter-fuel substitution elasticities obtained in this study to be more reliable.





## ***FUTURE R&D PROSPECTS IN DNI FORECASTING FOR AN EFFICIENT CSP INTEGRATION IN THE ENERGY MIX***

[Saad Benbrahim, Moroccan Agency for Sustainable Energy (Masen), Department of R&D and Industrial Integration, Complex Zénith Rabat N°50, Rocade Sud Rabat-Casablanca Immeubles A-B-C-D, Souissi, Rabat, Morocco, + 212 (0) 662 74 69 42, s.benbrahim@masen.ma]

[Ismail Belhaj, Moroccan Agency for Sustainable Energy (Masen), Department of R&D and Industrial Integration, Complex Zénith Rabat N°50, Rocade Sud Rabat-Casablanca Immeubles A-B-C-D, Souissi, Rabat, Morocco, + 212 (0) 662 13 75 53, i.belhaj@masen.ma]

[Hicham Bouzekri, Moroccan Agency for Sustainable Energy (Masen), Department of R&D and Industrial Integration, Complex Zénith Rabat N°50, Rocade Sud Rabat-Casablanca Immeubles A-B-C-D, Souissi, Rabat, Morocco, + 212 (0) 661 37 49 64, h.bouzekri@masen.ma]

### **Overview**

The Concentrated Solar Power (CSP) technology combined to Thermal Energy Storage (TES) is an important component in the energy mix as it contributes to electricity generation flexibility and offers the grid operator a quick responsiveness to ramping events ensuring the grid reliability. A CSP-TES system permits a higher solar energy penetration by lowering curtailments. By 2019, there are around 6.5 GW installed and operational CSP projects with an expected generation of 18.03 TWh per year worldwide. Countries including Spain, USA, Morocco, China, and South Africa make up 83% of the worldwide CSP installed capacity [1].

Direct Normal Irradiance (DNI) is the main component of CSP systems from which the electricity is generated. DNI forecasting is an important solution to overcome the problem of resource volatility and its accuracy is of great influence on the reliability of the grid and the profitability of the CSP plant output [2]. Several studies have shown the relevance of different forecasting horizons of Global Horizontal Irradiance (GHI), the main solar component of PV systems on the electric utility operational needs ranging from load following to unit commitment and transmission scheduling [3]. Although DNI and GHI are of an intermittent nature, many works have been conducted on the latter component, but to our knowledge, not as exhaustively on DNI forecasting which is of concern due to the beneficial financial value on CSP plants.

A study by Law et al. has evaluated the benefits of short-term DNI forecasts for different horizons on the updated bids for a 50 MW CSP plant with and without a TES of a 7.5-hour storage capacity and has confirmed the increase of the financial value by over \$0.8 million and a reduction in the equivalent forced outage rate (EFOR) by more than 20% in both cases [4]. Another work by Law et al. demonstrated the effect of DNI forecasting accuracy on the financial value using different error metrics for a CSP plant with a solar multiple between 1.25 and 2 and a TES between 0h and 20h. The study concluded that for a root mean squared error (RMSE) and a mean absolute error (MAE) in the range 325 - 400 W/m<sup>2</sup> and 250 - 300 W/m<sup>2</sup> respectively, a 1 W/m<sup>2</sup> improvement increases the financial value from \$ 400 to \$ 3600 per 6 months operation depending on the case [5].

This study investigates the future R&D prospects in DNI forecasting. In this paper, an analysis of DNI forecasting articles is conducted based on a selective literature review and the use of Knowledge Discovery in Data (KDD) to extract useful information and propose an outlook of possible research areas in the field.

### **Methods**

Bibliographic data used in the current study were collected from the Scopus database. Several filters and KDD tools were employed for data extraction, data analysis and bibliometric networks visualization.

### **Results**

#### **3.1 Evolution of publications for a decade of scientific research in the field of solar forecasting**



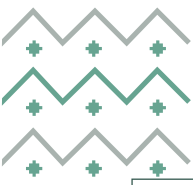


Fig.1(a) illustrates the noticeable trend in PV research contributions compared to the low evolution of publications on the CSP technology. Although Fig.1(b) displays an increasing trend on DNI and GHI publications, Fig.1(c) indicates a decreasing trend in DNI forecasting publications starting from 2017.

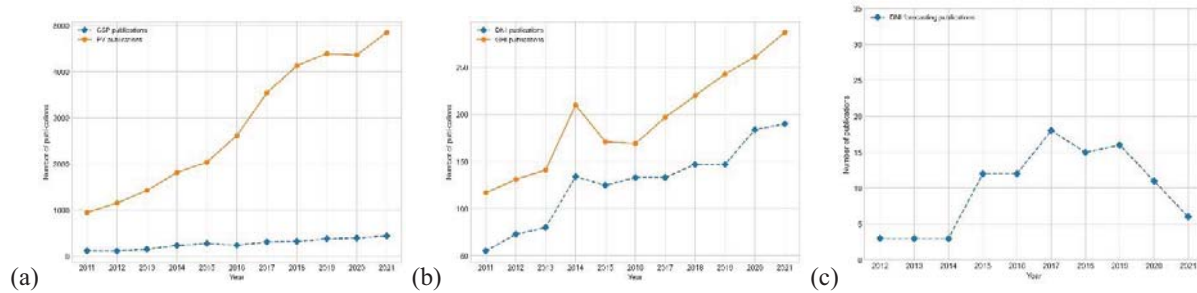


Fig. 1: Evolution of publications between 2011 and 2021 by (a) technology (CSP vs PV), (b) solar component (DNI vs GHI) and (c) DNI forecasting publications.

### 3.2. Analysis of DNI and GHI applied forecasting methods

Comparing Fig.2 (a) to Fig.2 (b) shows that a considerable number of forecasting methods have been applied on GHI compared to DNI which suggests a range of possible research areas to be explored.

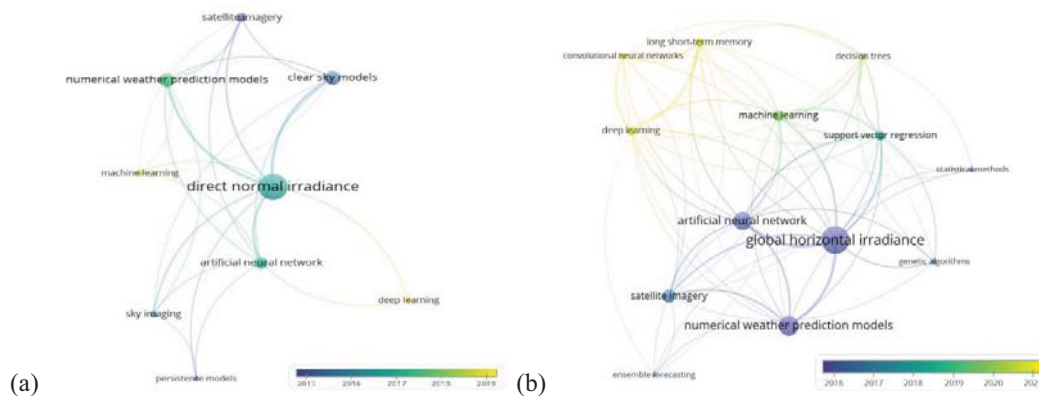


Fig. 2: Methods used in forecasting DNI (a) and GHI (b) with respect to time.

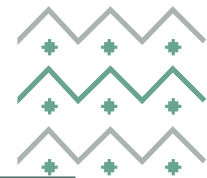
## Conclusions

In this work a literature review on DNI forecasting has been conducted to determine its future R&D trends due to the importance of this resource's forecast on grid stability. Results illustrated a lower trend in DNI forecasting compared to GHI with a discrepancy in short-term horizons especially Intra-day forecasts. Based on our findings, possible research opportunities should explore Intra-day DNI forecasts with an emphasis on planning update and load following applications.

## References

- [1]World Bank CSP Report, (2021). Concentrating Solar Power – Clean Power on Demand 24/7.
- [2]Law, E.W., Prasad, A.A., Kay, M., Taylor, R.A, Solar Energy, 108 (2014) 287–307.
- [3]Kumari, P. and Toshniwal, D, Journal of Cleaner Production, 318 (2021) 128566.
- [4]Law, E.W., Kay, M., Taylor, R.A., Solar Energy, 140 (2016) 93–108.
- [5]Law, E.W., Kay, M., Taylor, R.A., Solar Energy, 125 (2016) 267–281.





## A Tool for Measuring Countries' Circular Carbon Economy Potential and Progress: The Circular Carbon Economy Index

Fatih Yilmaz, KAPSARC, 0112903059, [fatih.yilmaz@kapsarc.org](mailto:fatih.yilmaz@kapsarc.org)

Mari Luomi, KAPSARC, 0112903037, [mari.luomi@kapsarc.org](mailto:mari.luomi@kapsarc.org)

Thamir Alshehri, KAPSARC, 0112903079, [thamir.shehri@kapsarc.org](mailto:thamir.shehri@kapsarc.org)

### Overview

There is an urgent need to align global carbon dioxide and other greenhouse gas (GHG) emissions with climate-safe trajectories. A broad range of technologies and approaches are needed to achieve this cost-effectively and equitably. The circular carbon economy (CCE) concept provides a holistic, flexible and pragmatic framework for countries to plan their respective contributions toward the commonly agreed climate goals. The CCE concept builds on that of the circular economy, with two important distinctions: it has an exclusive focus on energy and emissions, and it adds a fourth pillar to the three pillars of the circular economy: reduce, reuse, recycle, and *remove*. The fundamental goal of the CCE is to prevent atmospheric carbon dioxide and other GHG emissions. In addition, the CCE approach emphasizes economic incentives and benefits associated with managing carbon and the need to focus on the most cost-effective mitigation solutions. In this paper, we construct a composite index, the Circular Carbon Economy Index (CCE Index), which aims to measure countries' progress in, and potential for, achieving CCEs. The CCE Index is put forward as a tool for governments and climate change policy stakeholders to evaluate progress in support of domestic planning and decision making in the nexus of energy, emissions, and the economy. The CCE Index is based on two sub-indices: one for measuring countries' current performance in the various dimensions of the CCE and the other for gauging how countries are positioned to make progress toward the CCE, based on key enabling factors. The CCE Index also allows for additional comparisons among top oil-producing countries through a separate set of add-on indicators that capture how these countries' industrial performance are aligning with the CCE.

### Methods

The CCE Index methodology, as presented in detail in Luomi, Yilmaz and Alshehri (2021a), follows international best practice in composite indicator development, including guidance by OECD (2008) and UNECE (2019). The Index consists of two main subindices: Performance and Enablers. The Performance sub-index accommodates different climate change mitigation and emission circularity technologies under the four 'Rs', which reflect the need both for a mix of technologies and actions to reach net-zero (i.e., 'no silver bullet') and to accommodate for a multitude of country circumstances. The indicators of the Performance sub-index measure the following 'CCE activities': energy efficiency, renewable and nuclear energy, electrification, fuel switching, natural sinks, carbon capture, utilization and storage, and green hydrogen.

The Enablers sub-index is divided into five dimensions that reflect major, future-oriented determinants of successful transitions toward CCE, namely: policies and regulation; technology, knowledge and innovation; finance and investment; business environment and system resilience. Finally, the CCE Index is also extended to capture the specificities of oil and natural gas-producing countries. This is done by bringing additional indicators to the index. The second edition of the Index covers more than 60 countries, accounting for most of the global economy and GHG emissions.

The CCE index employs approximately 40 metrics that were originally selected from a list of roughly 150 potential variables, based on their relevance, reliability, and availability, among other criteria. The indicator framework was refined in 2022 to accommodate a larger number of countries and to improve conceptual clarity and indicator quality. In line with best practice, the Index only integrates harmonized datasets, but to enhance data coverage and quality, it uses both official (e.g., UN and other international organizations) and unofficial (e.g., academic literature) data sources. The selected metrics are rescaled with minimum and maximum boundaries to obtain scores (0–100), which are then equally weighted to create aggregated subdimensions, subindices and finally, the composite CCE Index. The authors also perform various robustness checks to ensure the quality of the Index. These checks include employing







different aggregation methods, such as principal component analysis, checking cross-validity for multi-collinearity, and also, considering correlations with other statistics and similar indices.

## Results

The high-level results indicate that no single country has yet achieved a full CCE (Figure 1), in which atmospheric carbon dioxide and other GHG emissions are minimized and circulated throughout the economy, where possible, to generate value. In the area of CCE Performance, on average, countries engaging in all CCE activities tend to perform higher in the Index. In the area of CCE Enablers, technology, knowledge and innovation gaps and lack of access to CCE finance are among the biggest obstacles faced by a large share of countries to accelerate their progress toward CCEs.

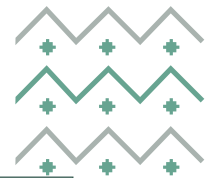
## Conclusions

The CCE Index is intended as a conversation starter for identifying the optimal ways of measuring CCE performance and enablers across countries. The CCE Index is updated regularly, and the Index framework is revised periodically to include additional indicators, improved and updated datasets, and new ways of measuring CCE performance and transition enablers. As of September 2022, the full 2021 CCE Index results with various interactive tools are available on the CCE Index web portal (<https://cceindex.kapsarc.org>), while the updated results for the 2022 CCE Index edition will be released during the 2022 UN Climate Change Conference (COP 27) in Sharm El-Sheikh, Egypt, in November 2022.

## References

- Luomi, Mari, Fatih Yilmaz, and Thamir Alshehri. 2021a. The Circular Carbon Economy Index 2021 – Methodology. KAPSARC Methodology Paper.
- Luomi, Mari, Fatih Yilmaz, and Thamir Alshehri. 2021b. The Circular Carbon Economy Index 2021 – Results. KAPSARC Discussion Paper.
- Organization for Economic Co-operation and Development (OECD). 2008. Handbook on Constructing Composite Indicators: Methodology and User Guide. OECD and European Commission's JRC. <https://doi.org/10.1787/9789264043466-en>
- United Nations Economic Commission for Europe (UNECE). 2019. Guidelines on Producing Leading, Composite and Sentiment Indicators. <https://doi.org/10.18356/3b565260-en>





## SHORT-TERM ENERGY FORECASTING SYSTEM FOR A PHOTOVOLTAIC POWER PLANT INSTALLED IN SOUTHERN ALGERIA: OUED NECHOU

Reski Khelifi, Mawloud Guermoui

Unité de Recherche Appliquée en Energies Renouvelables, URAER, Centre de Développement des Energies Renouvelables, CDER, 47133, Ghardaïa, Algeria.  
 razikreski@gmail.com

### Overview

Photovoltaic (PV) systems have the ability to preserve the economy and the environment in order to provide permanent energy to networks. On the other hand, when these PV systems have many variables, whether low or high, the unpredictability of the solar energy source is a particular problem in grid management. In this regard, photovoltaic forecasting is an important tool for managing uncertainty and ensuring system stability. In this work we present a robust forecasting model, based on mathematical methods, that aims to provide an estimate of the output power of PV farms for forecast horizons of less than 1 hour. This will allow the manager to better manage his electricity grid in the future by facilitating the integration of the solar energy supplier.

### Methods

The objective of this research is to evaluate the possibility of increasing the performance of PV power forecasting for a half-hour step. Predicting the random characteristic of hourly PV power with high accuracy is a very difficult problem. In this regard, a new hybrid prediction model is developed. The proposed model is mainly based on Gaussian Process Regression (GPR) as an essential predictor and the use of the CEEMDAN (Complete Ensemble Empirical Mode Decomposition with Adaptive Noise) decomposition method. ) as a preprocessing technique. In the following topic and in subsequent sections, for simplicity, the suggested model will be referred to as CEEMDAN-GPR [1,2].

### Results

The performance achieved with the use of our proposed method CEEMDAN-GPR with the endogenous variables CEEMDAN-GPR shows the reliability of the latter compared to the use of the single GPR model in the exogenous or endogenous case, the numerical results of the prediction of the output of the PV system in terms of R and the prediction errors shows that the hybridization of the CEEMDAN decomposition method with the GPR model improves the prediction performance of the GPR model with a significant reduction in the prediction error. The results showed the significant effect of the combination used on the accuracy of the CEEMDAN-GPR models. To demonstrate the accuracy of the CEEMDAN-GPR model, its predictions are compared to the classical model (GPR).

A comparison of the hourly PV power values predicted by the CEEMDAN-GPR hybrid model and its measured values is carried out. From these figures, it can be seen that the CEEMDAN-GPR {PV1...10} model has shown its effectiveness for the prediction of PV power and its outputs are in agreement with the observed values [3].

The results showed a significant improvement in the performance of the CEEMDAN-GPR model appearing in the statistical indices (see Table. 1, Fig.1)

Table 1. PV power prediction results by CEEMDAN-GPR hybrid model and GPR conventional model.

Model/Input	RMSE (Kw)	nRM SE	R(%)
GPR {PV-1}	127.69	27.31	88.23
GPR {Pr -1- Pr -10}	293.61	62.81	16.64
GPR {Hum -1- Hum -8}	280.84	60.07	39.22
GPR {V-1- V-4}	300.73	64.32	3.3
GPR {PV/Pr}	127.46	27.26	88.25
<b>GPR{T-1- T-8}</b>	<b>183.16</b>	<b>39.18</b>	<b>89</b>
<b>CEEMDAN-GPR {PV-1}</b>	<b>90.92</b>	<b>20.94</b>	<b>93.09</b>



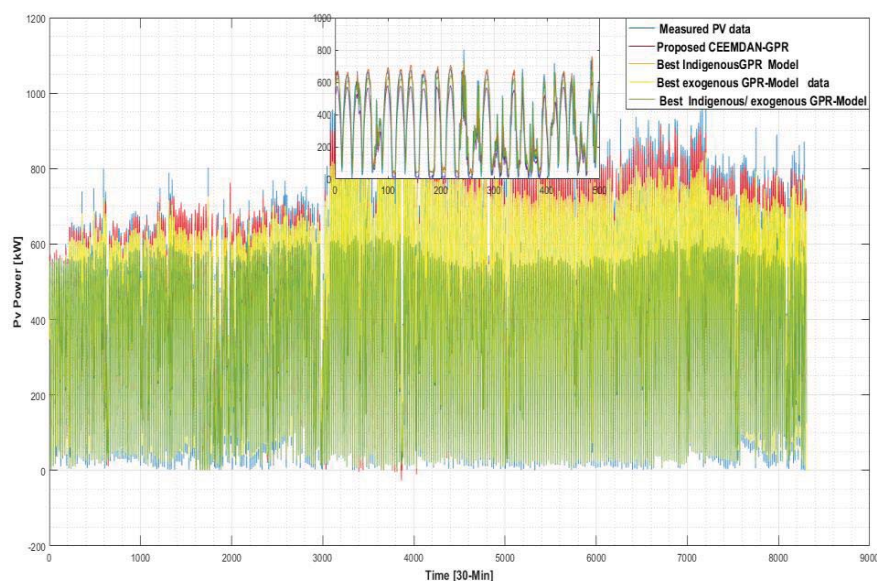


Figure 1. The PV power measured against the best estimated by the different sets.

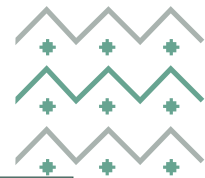
## Conclusions

The conventional model based on the GPR model was used and allowed the prediction of the time series of photovoltaic power on an hourly scale from that of meteorological data (exogenous variables) and PV data at the previous time (endogenous variables) as inputs. The performances are such that the correlation coefficient is 89.17 and the rRMSE is 38.84% from the meteorological data (exogenous variables), and the correlation coefficient is 88.23 and the rRMSE is 27.31% from the data of the PV power at the time preceding the predicted day (endogenous variables) as inputs. These performances have improved by the introduction of the CEEMDAN decomposition algorithm to decompose the input data. Consequently, the rRMSE improves by 18% from the exogenous variables, the rRMSE improves by 7% from the endogenous variables. The proposed CEEMDAN-GPR hybrid model brought a significant improvement to the in situ hourly PV power.

## References

1. Mohguen, Wahiba. Améliorations de la méthode EEMD. Diss. 2018.
2. Lin, Jinshan. "Improved ensemble empirical mode decomposition and its applications to gearbox fault signal processing." *International Journal of Computer Science* 9.6 (2012): 194-199.
3. Guermoui, Mawloud, et al. "New soft computing model for multi-hours forecasting of global solar radiation." *The European Physical Journal Plus* 137.1 (2022): 162.





## SUPPORT MECHANISMS FOR ACCELERATING DECARBONIZATION USING HYDROGEN

Alexander Hoogsteyn, KU Leuven & Energyville, +3216373330, alexander.hoogsteyn@kuleuven.be  
Kenneth Bruninx, TU Delft, k.bruninx@tudelft.nl  
Jelle Meus, KU Leuven & Energyville, jelle.meus@kuleuven.be  
Erik Delarue, KU Leuven & Energyville, erik.delarue@kuleuven.be

### Overview

Hydrogen and derived molecules generated through electrolysis can serve as energy carriers and chemical feedstock in a climate-neutral society. These CO<sub>2</sub>-neutral molecules can make a remarkable contribution to the climate neutrality of the material and chemical industry by the middle of this century. They allow emission-free production of fertilisers and steel, facilitate innovative processes in the chemical industry and may form the basis of sustainable synthetic fuels for shipping and aviation.

Many governments have announced ambitious hydrogen strategies, and therefore want to accelerate the deployment of renewable production and end-use applications. Since the zero-carbon hydrogen production technologies are not yet competitive with the traditional hydrogen production route, governments wish to support the required technologies to produce hydrogen sustainably and enable a carbon-neutral industry.

Previous research has studied the implementation of policies to support renewable electricity generation and the trade-offs between capacity- and energy-based subsidies (Özdemir et al., 2020). Research dedicated to bringing this knowledge to clean hydrogen production, while accounting for its differences, is currently sparse. Large-scale dedicated hydrogen support may nonetheless profoundly impact liberalised energy markets. For example, subsidising hydrogen production may increase wholesale electricity prices, contrary to renewable electricity support. The degree to which this effect will manifest depends on the selected policy instrument. Because electrolyser technologies are dispatchable, one should beware of any potentially distorting influence of these policy instruments on the operational decisions of hydrogen installations. The discussion is further complicated by the fact that different electrolyser technologies are available with different capital expenditures (CAPEX) and efficiencies. An optimal technology mix should address the system's needs: low-CAPEX variants with a poorer efficiency could for instance be preferred if renewable curtailment is prevalent. As has been shown for renewable electricity instruments, however, certain subsidy designs might distort the optimal technology mix. Another policy which could be applied to clean hydrogen production are Carbon Contracts for Difference (Richstein, 2017). While the cost of this policy mechanism has been studied, and a comparison with other policy instruments has been made (Vogl et al., 2021), research on the impact on cap-and-trade systems (e.g., EU ETS) and electricity markets is lacking.

To investigate the impact of the aforementioned policy instruments on energy markets and cap-and-trade systems, we develop a state-of-the-art model that captures the interactions between hydrogen, electricity and CO<sub>2</sub> emission markets which can be used to simulate the effect of different hydrogen support policies. Key questions will be addressed such as: what is the price effect on carbon- and electricity markets? How is the subsidy pass-through of the hydrogen support to hydrogen producers, hydrogen consumers and electricity producers? Which technologies are promoted by different policies? How much does a given policy increase electricity prices for consumers?

The compared support mechanisms are: i) A capacity-based investment subsidy (EUR/MW), ii) A quantity-based premium (EUR/MWh), iii) a hybrid quantity- and capacity-based mechanism which is a variant of a quantity-based premium that limits the amount of compensation according to a predetermined ratio of MWh per MW of installed capacity (Özdemir et al., 2020). While originally proposed in the context of RES support, we see particular use for this instrument in supporting hydrogen since the compensation limit can prohibit the electrolyser from being dispatched at moments with higher electricity prices. And iv) A Carbon Contract for Difference that guarantees the investors in carbon-neutral hydrogen a fixed carbon price (EUR/tCO<sub>2</sub>) for the duration of their investment. The remuneration is determined according to a benchmark linked to the carbon intensity of the total hydrogen production.

### Methods

To address our research questions we will employ the equilibrium model formulated as a mixed complementary problem and solution strategy developed by Bruninx et al. (2021). The model comprises of:

- An electricity market in which investors in gas-fired generation, wind, solar, and nuclear compete and optimize their operation considering the variable generation of renewables and demand for electricity.

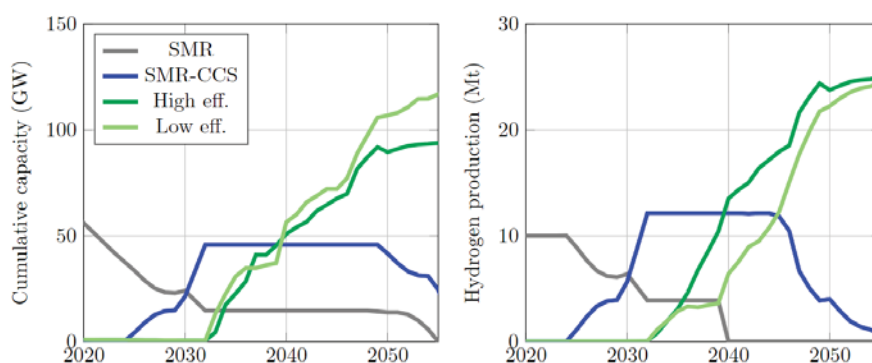




- A hydrogen market in which investors in different renewable hydrogen production technologies compete with traditional steam methane reforming (SMR) technology. Two electrolysis technologies are considered: a highly efficient one with higher CAPEX and a low efficient variant with a lower CAPEX. We furthermore include SMR equipped with carbon capture and storage (CCS).
- A cap-and-trade emission scheme in which the fossil-based electricity actors compete with SMR technology and a competitive fringe. The fringe has to decide either to buy emission permits or to bear the abatement cost, which is modelled as quadratically increasing. This actor represents the remainder of the industrial demand for emission allowances. Emission permits are bankable between all considered years 2020-2060 and borrowing is prohibited.

## Results

In our reference case without considering any support policies, we observe a gradual roll-out of SMR with CCS followed by the uptake of electrolysis-based hydrogen production and a gradual phase-out of legacy SMR production. Even though the low-efficient electrolysis solution has a 25% lower CAPEX than the highly efficient choice, they are both being installed.



Our preliminary assessment concerning the impact of policy schemes shows that both capacity and quantity-based instruments increase the installed capacity of carbon-neutral hydrogen technologies and can accelerate investments in these technologies. We observe that a capacity-based solution achieves this without affecting the operation of carbon-neutral technologies. However, a capacity-based solution does select technologies with a low CAPEX and does not encourage any additional learning effects into the higher efficient solutions.

## Conclusions

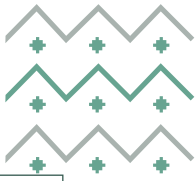
Having a mix of technologies in place to provide carbon-neutral hydrogen will be beneficial rather than favouring a single technology. Both capacity-based and quantity-based subsidy mechanisms can be used to increase the investment in electrolyser capacity. Care should be taken about how the chosen policy mechanisms affect the price signal on which electrolysers will base their dispatch since it may negatively affect economic efficiency. Subsidy schemes that support capacity generally distort the dispatch of electrolysers less compared to mechanisms that give a premium on produced quantity since they do not artificially increase the willingness to pay for electricity of agents operating electrolyser installations. Technologies with a lower installation cost benefit from mechanisms that remunerate capacity, while the more efficient technologies are cheaper to operate and may therefore be more cost-effective.

## References

- Bruninx K., Ovaere M., Delarue E., 2020, The long-term impact of the market stability reserve on the EU emission trading system, *Energy Economics*, Volume 89, 104746, ISSN 0140-9883, <https://doi.org/10.1016/j.eneco.2020.104746>.
- Özdemir Ö., Hobbs B.F., van Hout M., Koutstaal P.R., 2020, Capacity vs energy subsidies for promoting renewable investment: Benefits and costs for the EU power market, *Energy Policy*, Volume 137, 111166 <https://doi.org/10.1016/j.enpol.2019.111166>.
- Richstein J.C., 2017, Project-Based Carbon Contracts: A Way to Finance Innovative Low-Carbon Investments, DIW Berlin Discussion Paper No. 1714, <http://dx.doi.org/10.2139/ssrn.3109302>.
- Vogl V., Åhman M. & Nilsson L. J., 2021, The making of green steel in the EU: a policy evaluation for the early commercialization phase, *Climate Policy*, 21:1, 78-92, <http://doi.org/10.1080/14693062.2020.1803040>.







## Global Oil Market in Constrained Energy Transition Scenarios

Abdullah Aljarboua, KAPSARC, +966 11 290 3016, [abdullah.jarboua@kapsarc.org](mailto:abdullah.jarboua@kapsarc.org)  
Fatih Karanfil, KAPSARC, [fatih.karanfil@kapsarc.org](mailto:fatih.karanfil@kapsarc.org)  
Axel Pierru, KAPSARC, [axel.pierru@kapsarc.org](mailto:axel.pierru@kapsarc.org)

### Overview

Oil-producing countries are transforming and diversifying their economies. During the transition period, however, they will still rely on oil revenues to boost investments in the non-oil sectors.

This study aims to explore how, under various world energy transition scenarios, the evolution of the global economy will impact the international oil market equilibrium.

### Methods

We update and expand the equilibrium model developed by Rioux et al. (2022). It includes supply and demand fundamentals and potential global megatrends (such as international shifts in funds allocation). World oil demand is represented as a function of world GDP and oil prices. Further, we assume that the GDP growth depends on oil prices. On the supply side, alternative market structures can be designed. The model production decisions are based on short- and long-term piecewise linear supply curves. These supply curves are constructed using Rystad Energy Ucube dataset, which includes over 21,000 oil-producing assets. The model is calibrated to demand curves obtained from the International Energy Agency's (IEA) World Energy Outlook (WEO 2021). This model can be used to simulate the evolution of the global oil market in a world economy constrained by climate targets.

We will consider the Announced Pledges and Net Zero Emissions by 2050 Scenarios, which the International Energy Agency (IEA) introduced in its latest World Energy Outlook (WEO 2021), along with the Stated Policies Scenario to assess the impacts of various global climate and economic growth scenarios on global oil market fundamentals. More specifically, implications for oil-producing countries under each scenario will be analyzed. We will also be able to run alternative long-term simulations (up to 2050). The developed model will also enable us to study different international oil market structures (competition versus cooperation of suppliers).

### Results

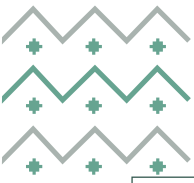
The model being currently developed will enable us to address the following questions:

- How would the global oil market respond to global climate targets?
- What could be the implications for oil-producing countries?
- Which hypothetical market structure would be beneficial for oil producers?

### Conclusions

The results of this study will provide policymakers with valuable insights regarding future oil market conditions and the implications on their national economies. Potential production strategies in the face of different world climate policy scenarios and international circumstances can be examined. Addressing those questions will provide insightful information regarding oil producers' position in a transitioning world economy. The insights derived from the model will help oil-producing countries plan their long-term economic development.

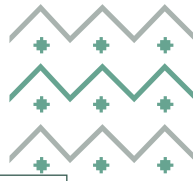




## References

Rioux, Bertrand, Abdullah Al Jarboua, Fatih Karanfil, Axel Pierru, Shahd Al Rashed, and Colin Ward. 2022. "Cooperate or Compete? Insights from Simulating a Global Oil Market with No Residual Supplier." *The Energy Journal* 43, no. 2.





## Forecasting of Korean Electricity Market Price Using Seasonal Decomposition Methods

[Arim Jin, Konkuk University, +82-10-3227-6825, [dooj2@konkuk.ac.kr](mailto:dooj2@konkuk.ac.kr)]  
 [DaHan Lee, Konkuk University, +82-10-5224-5564, [timeflow@konkuk.ac.kr](mailto:timeflow@konkuk.ac.kr)]  
 [JaeHyung Roh, Konkuk University, +82-2-450-3934, [jhroh@konkuk.ac.kr](mailto:jhroh@konkuk.ac.kr)]  
 [Jong-Bae Park, Konkuk University, +82-2-450-3483, [jbaepark@konkuk.ac.kr](mailto:jbaepark@konkuk.ac.kr)]

### Overview

In recent years, there has been an effort to forecast electricity prices. While a prediction of the price of the electricity market is estimated, it is important to reflect the structural characteristics of the market and price, such as calendar data, previous hourly price, fuel costs, seasonal temperature, and electricity demand set of time-series, which are affected by renewable energy generation. The Korean electricity market has a day-ahead market. The market closes at 10 A.M. the day before the operation. The secondary submission of renewable energy generation closes at 5 P.M. The Korean market is a Cost-Based Pool, so each generator must submit such data related to the operating costs nine days before the end of each month. In renewable energy, Solar generation occupies 92% of the variable renewable energy capacity in Korea.

To use the feature of time series, decomposition has been adopted. Some of the important time series elements are demand and renewable energy generation. Using them on point values makes it hard to reflect time series elements or variation. However, using lots of the previous time series elements of the exogenous variable as input data increases the dimension of the input variable and may degrade the prediction performance as overfitting. To solve these problems, decomposition methods have been adopted. They are the Mostly used and recently used methods on decomposition energy: Fourier transform, Wavelet transform, VMD(Variational Modal Decomposition), TBAT(Exponential smoothing state space model with BAT), and MSTL(Multiple Seasonal-Trend Decomposition), STR(Seasonal-Trend decomposition using Regression) based on STL(Seasonal-Trend decomposition procedure based on Loess).[1-3]

There are two benchmark papers. One study comparing AI approaches and statistical techniques shows that DNN, LSTM, and XGBoost outperform complex deep learning models such as CNN and RNN. Furthermore, complex hybrid models based on deep learning or machine learning performed less well than simply averaging compared to hybrid models.[4] Another paper compares multi-seasonal decomposition methods(TBAT, Prophet, AutoSTR, MSTL) to forecasts on univariate sets of related time series using LSTM. On hourly electricity demand forecasting, it is better to use seasonal components & original time series than trends & residuals.[5]

This paper uses seasonal decomposition methods to predict hourly electricity prices in the Korean market. Six forecasting models were compared, STR-LSTM, STR-DNN, STR-XGBoost, MSTL-LSTM, MSTL-DNN, and MSTL-XGBoost, based on the decomposition technique and model. In addition, inputting past SMP values as input values were compared by putting them in a multi-step time series method and a point value.

### Methods

The prediction model is divided into feature selection, seasonal decomposition, and training based on the models. The components mentioned above on the Korean electricity market are considered for the variable selection. 32 hours of the forecast was made, using monthly stepwise fuel prices of bituminous coal and natural gas, temperatures, and the size of the observation of each test was 3 months. The critical fuel price and the calendar data were also used as input variables and forecast prices.

On the pre-process, this paper calculates feature importance based on Random Forest. In the comparison of dimensions, the demand and the generation[kWh] are much more massive than SMP(System Marginal Price)[won/kWh], so it normalizes the components to decrease the errors.

The seasonal decomposition method is used for the value of demand and solar power generation. MSTL and STR decomposition methods were used, showing accurate performance in power demand prediction[4]. Both models are based on seasonal-trend decomposition. STL extracts the trends, seasonal and residual components by smoothing method using LOESS(local polynomial regression), which can neglect the outliers. MSTL can separate periodicity

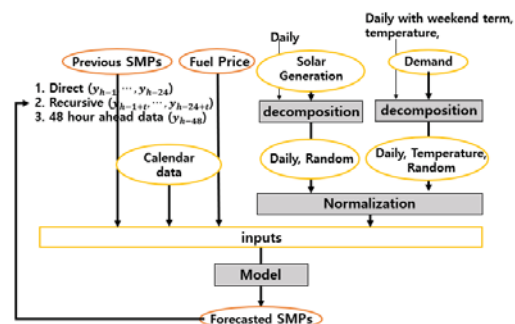
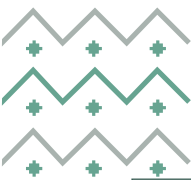


Figure 1. Proposed Method



from time-series elements using smoothness control. It repeats the process of the STL extraction, and elimination for each seasonal component. It can be quickly adopted if the length of the seasonal set is known. STR can extract multiple seasonal components and affect seasonal factors by introducing exogenous variables such as temperature, whether constant or time-vary components. Both models can separate the time-varies values into daily and residual parts. Then we ignored the trend components which tend to be non-oscillate because it hardly affects the short-term price. We choose daily and residual components.

In addition, modeling with LSTM, DNN, and XGBoost was compared, respectively, which are representative models of performing well in demand and price forecasting. Because previous SMPs every 24 hours have high feature importance than the others, this paper uses the 48-hour ahead last data. This paper compared Direct Strategy and Recursive Strategy, which are multi-step time series forecasting strategies.

## Results

In the evaluation, the tests were conducted ten times for 32 hours and evaluated based on two methods; MAPE(Mean Absolute Percentage Error) and RMSE(Root Mean Square Error). Each MAPE is calculated for the 32 hours forecast from 16:00 one day before the trading day to 23:00 on the trading day.

- The performance of XGBoost was recorded as the best in comparison with the other methods, in which the result of XGBoost is 33% to 48% higher in the average of MAPE than DNN, and 4% to 34% higher in the average of MAPE than LSTM.
- Comparing decomposition methods of STR and MSTL, using XGBoost and LSTM, which has a higher accuracy than DNN deep learning models, STR shows a 2% higher an average of MAPE.
- Figure 2 shows the result of comparison with the prediction with decomposition and without decomposition, prediction accuracy improved by 5 to 6% in the total average of MAPE on both models.
- The recursive strategy was 20% lower in an average of MAPE than the direct strategy, while the difference between XGBoost was less than 1%. However, compared to the case with a point-value of 48 hours earlier, the accuracy of the direct strategy is high in the model based on deep learning, but in the case of XGBoost, the model's accuracy with a point-value is higher.

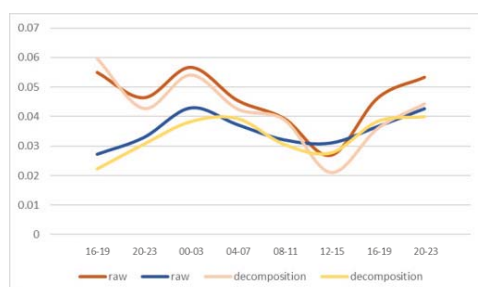


Figure 2. mean of the MAPEs, comparing between using decomposition and non-using

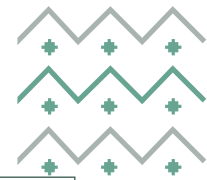
## Conclusions

This paper forecasts the Korean electricity market price using seasonal decomposition methods. It shows that the decomposition method is supportable for the prediction. However, this paper assumed the exogenous variables to be the same as the actual value. In future studies, the uncertainty of the external variable will be considered.

## References

- [1] Rafał Weron, "Electricity price forecasting: A review of the state-of-the-art with a look into the future," International Journal of Forecasting, Volume 30, pp1030-1081, October. 2014.
- [2] Fotios Petropoulos, Daniele Apiletti, Vassilios Assimakopoulos, etc., "Forecasting: theory and practice," International Journal of Forecasting, Volume 38, pp705-871, July. 2022.
- [3] Lingyun Wang, Tian Tian, Honglei Xu, Huamin Tong, "Short-Term Power Load Forecasting Model Based on t-SNE Dimension Reduction Visualization Analysis, VMD and LSSVM Improved with Chaotic Sparrow Search Algorithm Optimization," Journal of Electrical Engineering & Technology, May. 2022.
- [4] Kasun Bandara, Christoph Bergmeir, Hansika Hewamalage, "LSTM-MSNet: Leveraging Forecasts on Sets of Related Time Series With Multiple Seasonal Patterns," IEEE Transactions on Neural Networks and Learning Systems, Volume 32, pp1586-1599, April. 2022.
- [5] Jesus Lago, Fjo De Ridder, Bart De Schutter, "Forecasting spot electricity prices: Deep learning approaches and empirical comparison of traditional algorithms," Applied Energy, Volume 221, pp386-405, July. 2018.





## ***ON THE ROLE OF RESIDENTIAL BATTERY STORAGE AND PHOTOVOLTAIC SYSTEMS IN SHAPING BEHAVIOURAL CHANGES AND GENERAL WELFARE***

Liliana Nowakowska, Imperial College Business School, UK, +447428062225, l.nowakowska18@imperial.ac.uk

### **Overview**

Electricity markets are currently going through various changes: rapid increase in renewable energy, significant rise in carbon prices, appearance of new market players as well as more control being given to final users via smart meters which all create new challenges as well as opportunities in this multi-stakeholder grid. At the same time, we observe rapidly growing energy storage possibilities with the aim of providing some flexibility as well as new profit maximisation opportunity.

This means that decision making process in this changing environment has become even more complex, especially for final users. Domestic households are currently offered not only various electricity tariffs (i.e. Real-time pricing (RTP), Time-Of-Use (TOU) or fixed tariff), but they are also given many investment opportunities particularly in residential batteries energy storage system (BESS) and solar photovoltaic (PV) panels. This means that these electricity customers are gaining more power in controlling their daily electricity usage and thus the popular assumption of demand being inelastic is no longer valid.

The role of this paper is to research the impact of installing batteries and PV panels in households on the behavioural changes of final customers (demand curve and price of electricity). We assume that households use storage (batteries) for profit maximisation and react to the changing prices depending on their current tariff. We take into account the historical electricity prices and model the optimal price for final customers in different settings (maximizing social welfare) to compare the optimal prices for users with and without batteries and PV panels.

Apart from the intrinsic interest of understanding how equipping final users with above mentioned Distributed Energy Resources (DERs) changes the consumers behaviour, we model various different market set ups to present what-if situations including increasing storage and PV panels capacities and compare consumer surplus across different tariffs.

### **Methods**

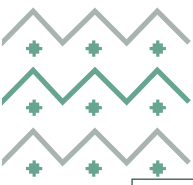
We present dynamic optimisation model that aims at maximising social welfare under different market settings. The primary purpose of the empirical analysis is to measure the effect of batteries and PV panels distributed among households as well as to identify the changes in consumer surplus across the groups.

Firstly, we assume initial market conditions where all households do not have neither storage nor PV panels. Next, we add storage unit and maximize households' energy cost savings by exploiting arbitrage – charging when the price is relatively low and discharging during peak hours. At the same time, we capture not only the effect of individual household's BESS on the daily demand curve and cost optimization but given the large amount of households we also observe the group impact on price levels as demand is significantly shifted from peak to non-peak hours.

Further, we equip part of the households with PV panels so that we can check what is the optimal usage of both Distributed Energy Resources together and how it impacts the households demand price. Additionally, we also allow some of our final customers to have only PV panels without any batteries installed. This way, we can check for times of energy excess and compare the daily prices and demand curves. We can also answer whether the simultaneous investment in PV panels and batteries significantly improves the daily energy savings.







We check the results for each scenario with different batteries and PV panels capacities to measure the prospective profitability of investing in additional units. Altogether, we provide broad outlook on final customers electricity market with storage and PV panels investments across various market set-ups.

## Results

Our analysis show couple of interesting findings including the expected mechanism of reducing market prices in peak hours and increasing them in off-peak hours for customer with batteries. The preliminary results state that installing only PV panels brings around 10% savings on the electricity bill and adding BESS can increase the savings up to 45% compared to the households without any DERs. The shift in demand curve is substantial – the peak hours are barely distinguishable as consumer use mostly accumulated energy during the day.

We also observed that during the sunny day, batteries were usually charged at full capacity before the afternoon due to the excess of PV export and so the additional export directly to the grid or bigger battery is advised. Once we have refined our current scenarios, we will be able to optimize the capacity of BESS taking into account the initial costs of investments.

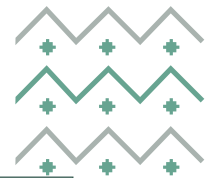
## Conclusions

Storage can induce both private and social returns by creating profits or by impacting consumer surplus and social welfare respectively. In this paper, we research the impact of equipping individual households with batteries in PV panels to identify the changes in energy consumption and potential cost savings.

We present the model that not only simulates but also optimizes residential load profiles in the presence of DERs and different tariffs. The model is calibrated based on data from smart meters in UK households. We identified many benefits, especially for investment in battery systems which results in reduction of energy bill and consumption from the grid during peak hours.

At the same time, we observe that system of batteries is not currently economically competitive, and the policymakers should provide incentives in the form of subsidies to encourage customer to invest in storage. If that kind of subsidies are not possible for all potentially interested households, the group of particular customers with high demand profiles should be selected. We also found that the combination of both PV panels and storage system investment is yet not feasible due to very high initial costs but that may change soon due to technical advancements so researching that option is also vital.





## Modelling the future of energy: What are the present tools missing?

[Afsal Najeeb, Research Scholar, IIT Bombay, India, +91-9446257886, afsaln.india@gmail.com]

[Anand B Rao, Professor, CTARA, IIT Bombay, India, a.b.rao@iitb.ac.in ]

[Satish Agnihotri, Professor, CTARA, IIT Bombay, India, sbagnihotri@iitb.ac.in]

[Vinod Mishra, Professor, Monash University, Australia, Vinod.Mishra@monash.edu]

[Srinivas Sridharan, Professor, Monash University, Australia, Srinivas.Sridharan@monash.edu]

### Overview

Energy modelling is the process of creating computational or mathematical models of energy systems to analyze them. Modelling an energy system is inherently complex as it has to incorporate technology detail, macroeconomic feedbacks and behavioral patterns from a wide range of supply and demand sectors. Energy models provide a means of understanding possible future scenarios and evaluating competing policy options, especially in the contexts of energy security and low carbon growth. Standard modelling tools and approaches are commonly used by industry and academia to generate international or national models. The International Energy Agency (IEA) has estimated that developing countries would contribute majority of the growth of energy demand and hence emissions over the next twenty years<sup>1</sup>. Two broad contours would determine the energy usage path chosen by developing countries – the need for improved standard of living for its citizens and its implication of energy choices for climate change. Quality energy models customizable to local contexts are necessary to ideate transition policies.

The paper argues that while there are many modelling tools available, the widely used modelling tools have been developed with a particular worldview and there is ample scope for value addition. A list of available energy models were compiled using systematic literature review. The characteristics of the tools were studied and captured using twenty indicators falling under three dimensions. The tools were also ranked based from the perspective of their utility for energy planning at the district level considering the context of a middle income country. The study shows that while there has been a near standardization in modelling capabilities, there is scope to include more qualitative dimensions, demand side specificities, Geographic Information System (GIS) integration in the reviewed tools. Free availability, specifically in the form of interactive web based platforms or stand alone software could lead to widespread use of such tools by decision makers at all levels. The review provides a baseline manual for energy planners for choosing the right tool or approach depending on the context, scale, purpose, features and available resources.

### Methods

A three-step methodology was used for the study.

1. Identification of models for review
2. Qualitative review of their features
3. Ranking of the models based on a set of criteria to understand their suitability for local level energy planning.

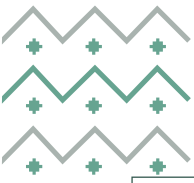
A systematic literature review was conducted to identify the list of energy modelling tools to be studied. It was followed by a detailed analysis of the selected tools using documentation and scholarly publications reporting their usage. Open source and proprietary models were included in the survey. The methodology of analysis included qualitative review of the model documentation, creation of use cases and review of secondary literature. The analysis was systematiswd by creating a ranking framework with twenty indicators spanning three dimensions viz. a viz. general properties, ability to model energy systems and ability to generate results in desired form.

### Results

The study finds that energy modelling tools have widely been developed considering the context of developed countries as indicated by the country of origin, sectors considered and modelling objectives. There is considerable scope to include socio economic parameters, adjustments for data sufficiency etc. to make them more relevant in the context of developing countries. Web based dashboards with ability to model local energy systems would be a useful tool for planners at lower levels of governance. Availability of tools free of cost, availability of training material and GIS integration would be other desirable characteristics.

In the score based ranking exercise, software tools like LEAP and HOMER along with modelling framework MARKAL / TIMES have high scores followed by web based dashboard IESS 2047. High scores across all three individual dimensions have resulted in the high overall scores. Other tools like EnergyPRO and OSeMOSYS have high ability to model the system but fall marginally behind in other dimensions. Most tools perform badly for indicators like data requirements and visualization of results and GIS integration. Modelling softwares and modelling



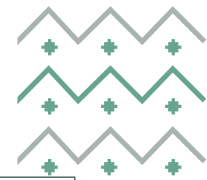


frameworks like LEAP, MARKAL / TIMES, HOMER and OSeMOSYS have high ability to model the system but are relatively less attractive general properties.

### **Conclusions**

The study reviews ten energy modelling tools and approaches with the aim of understanding their limitations in their present form and the utility for decentralized energy planning, specifically in the context of developing countries. The features of relevance have been captured and systematically recorded using twenty indicators across three dimensions viz. a viz. general features, ability to model an energy system and the ability to generate results. Energy modelling tools have widely been developed considering the context of developed countries as indicated by the country of origin, sectors considered and modelling objectives. There is considerable scope to include socio economic parameters, adjustments for data sufficiency etc. to make them more relevant in the context of developing countries. Web based dashboards with ability to model local energy systems would be a useful tool for planners at lower levels of governance. Availability of tools free of cost, availability of training material and GIS integration would be other desirable characteristics.





## TIME-VARYING PRICE ELASTICITY OF ELECTRICITY DEMAND

Jieyang Chong, University of Reading, +44 (0) 118 378 4606, j.chong@reading.ac.uk  
 Jacopo Torriti, University of Reading, +44 (0) 118 378 8196, j.torriti@reading.ac.uk

### Overview

The ability to induce shifts in electricity load within a day may reduce costs for a number of reasons. Lowering daily peaks or managing foreseeable spikes in demand are useful for system security. Similarly, taking advantage of favourable weather conditions with respect to generation of renewable energy could also be achieved through successful load-shifting. One of the ways in which this outcome can be targeted is through the use of financial incentives. In designing a suitable monetary incentive or deterrent for consumption, knowledge of the expected demand response to an effective change in electricity price is key. In the context of intra-day shifting, understanding how the profile of price elasticity varies within a day is of particular relevance.

Estimation of intra-day patterns in price elasticity of electricity demand has received limited attention in the literature (Fan and Hyndman, 2011; Knaut and Paulus, 2016; Kulakov and Ziel, 2019; Chong, 2021) and has recently become topical in light of the gas shortage and soaring electricity prices in Europe. This study proposes a new econometric approach which introduces smoothness in the intra-day pattern of elasticity, and preserves this smoothness of elasticity at all times of the day. Smoothness in elasticities is argued in the paper to be characteristic of data which captures aggregated consumption behaviour (e.g. whole population, the residential sector, all office buildings in a city) as opposed to individual or household-level data. Since time of day is measured in a cyclical manner, it follows that if elasticity is smooth, it must be so in a cyclical manner. In other words, even though each day arbitrarily starts at the first measurable moment after midnight, when elasticity between midnight and this time is continuous, it can be considered to be "smooth everywhere".

### Methods

The method proposed in this paper follows an econometric modelling approach not dissimilar to those in existing works. A linear model of the form

$$q_t = cp_t + \mathbf{x}'_t \boldsymbol{\beta} + \varepsilon_t, \quad (1)$$

in which  $q_t$  represents electricity demand at time  $t$ ,  $p_t$  represents price, and  $\mathbf{x}_t$  is a vector of other variables with explanatory power on demand including an intercept. The coefficients  $c$  and  $\boldsymbol{\beta}$  are to be estimated. The way in which demand and price enter the equation as  $q_t$  and  $p_t$ , respectively, varies between being the natural logarithms or raw levels in the literature. For example, Tiwari and Menegaki (2019) use logarithms for both variables, Fan and Hyndman (2011) uses a log-linear model in which demand is in logarithms and price is in levels and also a log-log model, and Lijesen (2007) uses both a linear model as well as a log-log model. Price elasticity estimates are then obtained from some transformation of the estimate of  $c$  in (1), depending on whether  $q_t$  and  $p_t$  are in logs or levels.

Unlike Fan and Hyndman (2011) and Knaut and Paulus (2016), the proposed method for estimating a daily pattern in price elasticities fits a single regression equation to the data instead of performing a regression for each intra-day period. This approach makes it easy to test whether a daily pattern exists. Variations in price elasticity can be introduced by including an interaction variable between price and a dummy variable for each intra-day period as in

$$q_{d,h} = c_0 p_{d,h} + \sum_{j=1}^{H-1} c_h \mathbb{1}(h=j) p_{d,h} + \mathbf{x}'_{d,h} \boldsymbol{\beta} + \varepsilon_{d,h}, \quad (2)$$

where  $d$  is the day in the sample,  $H$  is the total number of periods per day, and  $h$  is the intra-day period. The function  $\mathbb{1}(\cdot)$  takes the value 1 if its argument is true and 0 otherwise. The equivalence between subscripts in (1) and (2) is given by  $t = (d-1) \times H + h$ . The estimated price elasticity at the  $h$ -th intra-day period is then computed using  $c_0$  and  $c_h$ , with the elasticity at the  $H$ -th period computed using only  $c_0$ . Testing the joint significance of  $c_1, \dots, c_{H-1}$  is effectively checking for evidence of variation in price elasticity throughout the day. Note, however, that (2) does not impose smoothness on elasticities even if  $H \rightarrow \infty$ .





An alternative way of introducing easily-testable variation in price elasticities throughout the day is through the model

$$q_t = cp_t + \sum_{s=1}^S \left[ \gamma_s \sin \left( \frac{2s\pi(t-H)}{H} \right) + \delta_s \cos \left( \frac{2s\pi(t-H)}{H} \right) \right] p_t + \mathbf{x}_t' \boldsymbol{\beta} + \varepsilon_t, \quad (3)$$

where  $S$  can be selected using the data. In this application, the value of  $S$  is selected by recursively increasing the value from  $S = 0$  until some  $S = S^*$  such that  $\gamma_{S^*+1}$  and  $\delta_{S^*+1}$  are both not statistically significant. If  $S > 0$ , then price elasticity throughout the day is not constant. This Fourier approximation estimates a repeated pattern of elasticity within each day and ensures that elasticity is smooth throughout the sample.

All three models are estimated by two-stage least squares using  $p_{t-1}$  as an instrument for  $p_t$ .

## Results

Using hourly data from the German wholesale market for the year 2016 which is obtained from the European Power Exchange (EPEX), price elasticity is estimated by (i) fitting model (1) to the whole sample (constant elasticity), (ii) fitting model (2), and (iii) fitting model (3). Since prices in this sample fall below 0, the logarithm of price is not defined for the whole sample, and the log-log specification is not feasible. All models are estimated with linear (demand and price in levels) and log-linear (logarithm of demand and price in levels) specifications.

The joint tests from (2) and (3) both indicate that there is variation in price elasticity of electricity demand within the day. Estimates of price elasticities using both models exhibit similar patterns, with a range of values which includes the constant estimate from (1). The pattern of estimates from the dummy variable model described in (2) is noticeably less smooth than those of (3), especially between 1500–2100hrs. Electricity demand is found to be most elastic between 2100hrs and midnight, and least elastic around 0700–0800hrs and between 1800–2000hrs. Intra-day elasticities from (2) and (3) fall within similar ranges of price elasticity whether a linear or log-linear specification is used.

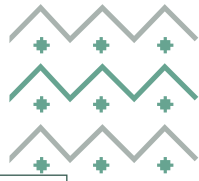
## Conclusions

This paper proposes a new and simple way to estimate smooth variations across the day in price elasticity of electricity demand. The proposed method also provides an easy way to test whether price elasticities are constant throughout the day or whether there is evidence of variation.

Applying the approach to German wholesale electricity data provides estimates for price elasticities which vary throughout the day and this variation is found to be statistically significant.







## Models of the Demand for petrochemical feedstocks worldwide

Raed Al Mestneer, Kapsarc, Riyadh, Saudi Arabia, [raed.mestneer@kapsarc.org](mailto:raed.mestneer@kapsarc.org) 0112903087  
Carlo Andrea Bollino, Kapsarc, Riyadh, Saudi Arabia, [carlo.bollino@kapsarc.org](mailto:carlo.bollino@kapsarc.org) 0112903090

### Overview

Oil is presumed to remain the fuel with the largest share in the energy mix over the forecast period, led by demand from transportation and petrochemicals. Combined, oil and gas are still expected to make up more than 50% of the global energy mix by 2040. The Petrochemical sector has experienced a high growth rate for the last twenty years (4% annual). Demand growth in industry is driven mainly by the petrochemical sector, with demand forecast to increase by 4.5 mb/d from 2017–2040, from all regions in the world. The strong performance of the petrochemical industry is expected to require additional volumes of natural gas as feedstock. In this context, we want to model the demand for the main feedstocks, Naphta, Ethane, LPG, Other oil products for the 10 regions of the world. It is important for the model to track the developments of the industry, due to price changes in the inputs and in the final uses. The model is used to construct alternative scenarios.

### Methods

We model demand functions for 10 regions and four feedstocks as function of prices and GDP and other exogenous variables, with annual data in the period 1971–2020. We cast a ARDL model with lag = 1:

$$X_{ij} = a_0 + \sum a_{ij} \ln(p_j) + b_i Y_i + c_i Z_i + d X_{ij,t-1} + e_{ij}$$

Where:

X = quantity demand

p = international prices

Y = GDP

Z = other exogenous variables

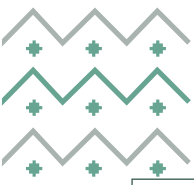
j = Naphta, Ethane, Lpg, Other oil products

i = World, OECD Americas, OECD Asia Oceania, OECD Europe, Africa, Non-OECD Americas, Middle East, Non-OECD Europe and Eurasia, Non-OECD Asia (excluding China), China (P.R. of China and Hong Kong, China)

### Results

We obtain good and robust econometric results. We validate the estimations with in-sample forecast for the last two periods. We performed the estimation excluding the last two periods of the sample and then we run out of





sample forecast checking whether our dynamic simulation is consistent with historical data of the last two years. We use the root mean squared error as a check.

We compare our results with the existing international sources like the OPEC Report and the IEA World Energy Outlook.

## Conclusions

This is the first econometric attempt of KAPSRC to model the petrochemical feedstock demand in a long term perspective for a detailed number of regions of the world separately for the main feedstocks our scenario our model is a useful tool to help policymakers to assess the trajectory and the trends of the long term industrial and technological developments in the field of Petrochemicals

## References

Towards circular carbo-chemicals – the metamorphosis of petrochemicals, Energy & Environmental Science, 2021, DOI: 10.1039/d1ee00532d J.-P. Lange)

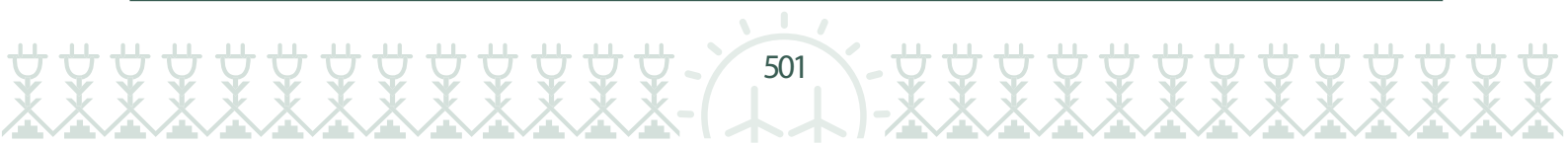
Liu, Feng , Shuai Shaob, Chuanguo Zhang (2020) How do China's petrochemical markets react to oil price jumps? A comparative analysis of stocks and commodities, Energy Economics 92 (2020) 104979

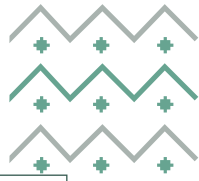
OECD, Improving Plastics Management: Trends, policy responses, and the role of international co-operation and trade, Background Report, Prepared by the OECD for the G7 Environment, Energy and Oceans Ministers, September 2018

OPEC, World Oil Outlook 2040, Opec 2018

IEA, The Future of Petrochemicals Towards more sustainable plastics and fertilisers available online at [www.iea.org](http://www.iea.org) INTERNATIONAL ENERGY AGENCY 2018

IEA, World Energy Outlook, Paris, 2020





## Minimizing Oil Revenue Volatility For Saudi Arabia: Statistical Analysis And Impact Overview

[Khalid Aldubayyan, Oil Sustainability Program, 0555001497, Aldubayyank@gmail.com]

[Abdulkarim Alfalaj, Saudi ARAMCO, 0591234044, Abdulkarim.fahad7@gmail.com]

[Ali Alsaeed, Accenture, 0553330018, [Alialsaeed@aol.com](mailto:Alialsaeed@aol.com)]

[Abdullah Alayed, King Abdullah City for Atomic and Renewable Energy, 0502201120, AbdullahAyed.sa@gmail.com]

### Overview

The study discusses the challenges and opportunities within the energy sector, with all the transitions it is having nowadays. One of the main challenges facing the energy sector is the volatility of oil prices. This presents severe pressure on oil-dependent economies from both supply and demand points of view. From the perspective of oil exporting countries like Saudi Arabia, this challenge can be mitigated by finding the optimal hedging strategy using downstream, especially refineries. This was analysed using a stochastic simulation modelling approach to find the optimum refining capacity in Saudi Arabia in terms of maximum average revenue and minimum revenue volatility.

### Methods

The optimization engine process:

1. Extract historical monthly oil prices from 1990-2022 June, opening, closing, and average.
2. Develop two data sets, one with the prices as is, and the other with the prices inflated (trended) to 2022 levels using consumer price index (CPI).
3. Fit both data sets to mixture of continuous distributions (Weibull and Lognormal) to generate additional data points from (interpolation and simulating data points).
4. Generate 100M simulated data points of oil prices.
5. Perform stochastic simulation by randomly choosing a price for 100k points (as a yearly average).
6. Once simulations were generated, construct a trade-off balance formula between the total revenue and revenue variance for each simulated price. This allows us to choose the best allocation between downstream and upstream to maximize the revenues while maintaining optimal minimum revenue volatility across scenarios.

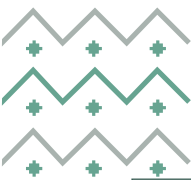
### Results

The analysis result suggests to increase Saudi Arabia's refining capacity by 20-40% of its current capacity. This will allow Saudi Arabia to have high sustainable level of oil revenue while maintaining minimal level of variation across the years.

### Conclusions

This study has shed the light on the issues related with the overreliance on oil as the main revenue source for Saudi Arabia. The stochastic simulation analysis conducted aimed to address oil price volatility issue and suggested to increase Saudi Arabia's refining capacity by 20-40% of its current capacity to achieve optimal situation. Moreover, that would also have other positive impacts on the Saudi economy via increasing diversification, ensuring sustainable oil demand, and attaining more local content development while leveraging Saudi comparative advantages.





## ***A TECHNO-ECONOMIC ANALYSIS PERSPECTIVE ON HYDROGEN PRODUCTION AND UTILIZATION FOR INDIA***

[Sukriti Sharma, Chemical Engineering-Indian Institute of Technology Ropar, India, 0091-8219135422,sukriti.chz0001@iitrpr.ac.in]

[Asad H. Sahir, Chemical Engineering-Indian Institute of Technology Ropar, India, 0091-9772271581,asad.sahir@iitrpr.ac.in]

[Other Author's Name, Affiliation, Phone, email]

### **Overview**

The rapid shift in the scientific outlook due to climate change and global warming has led researchers to actively pursue carbon neutral or net-zero alternatives. The COP 27 is scheduled in Egypt, in November 2022, and the world is looking toward its leaders to develop robust climate-resilient approaches. India announced its National Hydrogen Mission during the Union budget in 2021. Hydrogen is considered one of the prominent energy options and a rationale in low-carbon energy systems. With the decarbonization of energy systems and critical developments in hydrogen production technologies, the prospect for hydrogen to play a substantial role in energy systems has become realistic. The research and development of hydrogen production methods are gaining momentum, to develop a hydrogen economy in the future and to meet net-zero goals for India by 2070.

This conference paper will showcase a techno-economic analysis and comparative analysis of different hydrogen production methods for an Indian scenario utilizing open-source tools developed by the US Department of Energy's Office for Energy Efficiency and Renewable Energy Hydrogen Program and understanding the application of its fundamental assumptions. The different production methods for hydrogen include biomass gasification, solid oxide electrolysis, polymer electrolyte membrane electrolysis, and steam methane reforming. A Techno-economic analysis has been carried out to estimate the cost of hydrogen via these production methods and then a comparison is drawn to explain the cost of hydrogen by these production methods. This paper also utilizes an Excel-based model developed by the US Department of Energy, HDSAM (Hydrogen Delivery Scenario Analysis Model) for modeling the cost of delivering hydrogen from a central production facility into a vehicle. The delivery infrastructure deploys all transport, storage, and conditioning activities from the outlet of the Hydrogen production plant to the fueling station. The paper will also showcase the results of in-house process engineering models developed by the authors at the Indian Institute of Technology Ropar.

### **Methods**

#### **H2A**

The cost analysis is performed by using the H2A Production model developed by the Department of Energy (DOE) Hydrogen program. The model examines the technical and economic aspects of different hydrogen production technologies. The model considers a standard discounted cash flow methodology and a specified after-tax internal rate of return from the production technology. It uses the Microsoft Excel spreadsheet analysis tool for the calculation of the Levelized cost of hydrogen. It requires detailed input variables such as plant performance information along with the financial and cost information to run a plant. There are a standard set of assumed assumptions that the model uses to ensure consistency.

#### **HDSAM**

Hydrogen Delivery Scenario Analysis Model (HDSAM), is an Excel-based model that estimates the cost of delivering hydrogen from a central production facility to a hydrogen-fuelled vehicle. The Infrastructure and refueling techno-economic assessments use a set of Excel macros which is a recording of regular steps in excel, Infrastructure, and refueling techno-economic assessments use an engineering economics approach to cost estimation. For a given scenario a set of "components" (e.g., pipelines, compressors, storage vessels, tube trailers, etc.) are specified, sized, and linked into a simulated delivery system or pathway. Technology cost and performance assumptions are then combined with system financial assumptions to compute the contribution of these components to the delivered cost of hydrogen

### **Results**



Recently we have begun analysis on a case study for Davis, CA (USA) using the Hydrogen Delivery Scenario Analysis Model [A3]

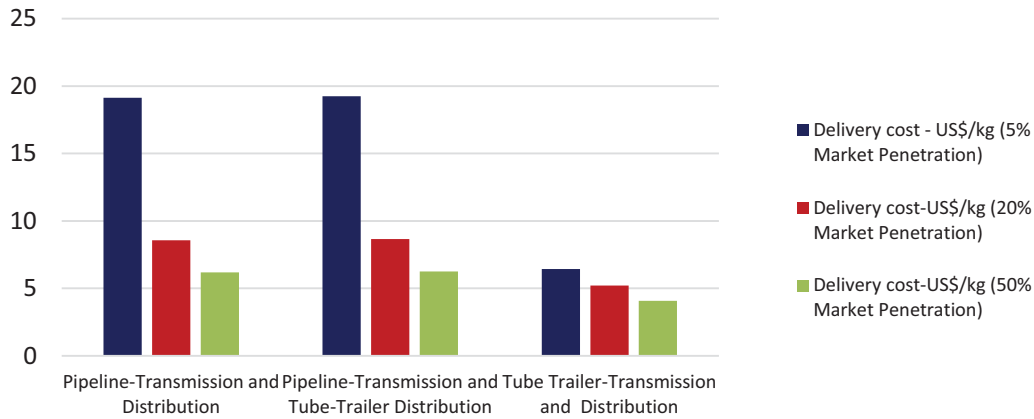


Figure 1. Delivery Cost of H<sub>2</sub> (US\$/kg) by HDSAM Model (Desired dispensing rate 2000 kg used/day) at HIGH production volume for Davis, CA (USA)

### Conclusions

Our study will estimate the present cost of hydrogen with different production methods. A comparative analysis is drawn to understand the difference between the cost of grey, blue and green hydrogen. This study will help understand the prospects of using blue and green hydrogen in India. Gray hydrogen currently constitutes a market of \$150 billion. But gray hydrogen is mainly a major polluter, the focus will be turned to producing blue hydrogen which is with carbon capture and storage. There is also an indication that the climate impact of blue hydrogen production would be similar to green hydrogen if emissions are minimized. While there is a lot of hype regarding green hydrogen, all the cost factors should be taken into consideration such as the price of producing green hydrogen.

### References

- [1] M. Penev, G. Saur, C. Hunter, J. Zuboy .”H2A Hydrogen Production Model Version 3.2018 User Guide- Draft 11/9/18”
- [2] NITI Aayog- “Harnessing Green Hydrogen “ , Report / June 2022
- [3] Will Hall, Thomas Spencer, G Renjith, Shruti Dayal -”The Potential Role of Hydrogen in India : A pathway for scaling-up low carbon hydrogen across the economy”, The Energy and Resources Institute (TERI)
- [4] Shrila M. , Sharma S. , Sahir A.H.,”Techno-economic analysis of hydrogen delivery structure infrastructure”., International Conference on Enabling Transition towards Sustainable Future September 8-10,2022





**[STRATEGIC COMMODITIES' PRICE RISK AND FINANCIAL CONTAGION IN OIL  
IMPORTING AND OIL EXPORTING COUNTRIES]**

[Ilyes Abid, ISC Paris, +33695876651, [ilyes.abid@gmail.com](mailto:ilyes.abid@gmail.com)]

[Saad Alshammari, University of Rhodes Island, USA, [saalshammari@uri.edu](mailto:saalshammari@uri.edu)]

[Khaled Guesmi, Paris School of Business, Paris, France, +33669165188, [k.guesmi@psbedu.paris](mailto:k.guesmi@psbedu.paris)]

[Ramzi Benkariem, Audencia Business School, Nantes, France, [rbenkariem@audencia.com](mailto:rbenkariem@audencia.com)]

[Christian Urom, Paris School of Business, Paris, France, +33755206687, [c.urom@psbedu.paris](mailto:c.urom@psbedu.paris)]

### Overview

In this paper, we test for the existence of stock market contagion effect, originating from strategic commodities price fluctuations from April 2000 to April 2022. We apply the augmented multifactor asset pricing model to capture the unexpected return and separate simple correlation due to fundamentals and contagion during the recent COVID-19 and Russian-Ukraine induced financial market crises. Also, we consider segmentation versus integration process. If individual stock markets and regions are perfectly integrated but unexpectedly experience their correlations coefficients rising, our test rejects the null hypothesis of no contagion. If, however, stock markets are perfectly segmented, the increased correlations may essentially be a consequence of increased factor volatility.

### Methods

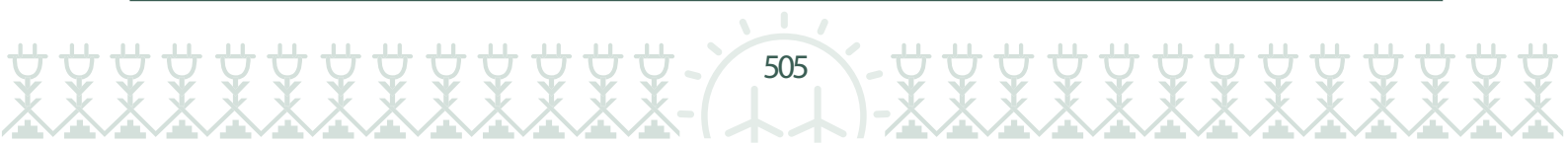
The model closest to ours is that of Bekaert et al. (2005), which considers the contagion effect as correlation among model residuals, allowing for time-variation in expected returns risk prices.

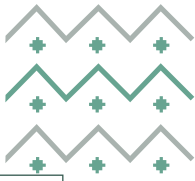
The main contributions of our study to the literature on contagion effects are as follows: (i) we consider the dynamics of strategic commodities prices risks, which are crucial in the case of international portfolio choice, (ii) we make clearly the difference between simple correlation due to fundamentals, or to contagion in the empirical multifactor asset model, and (iii) we consider asymmetric effects and enable stock markets to vary through time.

We introduce strategic commodities price risks as an additional channel of contagion in the category of global risks and we consider the sub-periods of crises and investigate whether our model can generate sudden increases in correlations. Our results show a robust test for international, regional market and oil price risks and the time variation and cross-sectional patterns in intra-regional versus regional correlations.

### Results

Our results will provide strong evidence of contagion effects originating in the international equity





markets toward the oil exporting countries. This effect becomes evident when considering correlations, in which the comovements with the international market are the strongest. The role of oil and gas is found significant in the variance decomposition and in the dynamic correlations, giving evidence of a factor that can amplify financial contagion, whenever it exists.

### Conclusions

This paper tests for the existence of stock market contagion effect, originating from strategic commodities price fluctuations from April 2000 to April 2022. We apply the augmented multifactor asset pricing model to capture the unexpected return and separate simple correlation due to fundamentals and contagion during the recent COVID-19 and Russian-Ukraine induced financial market crises. Also, we consider segmentation versus integration process. The role of oil and gas is found significant in the variance decomposition and in the dynamic correlations, giving evidence of a factor that can amplify financial contagion.

### References

Bekaert G., C.R. Harvey and A. Ng., (2005). Market integration and contagion, *Journal of Business*, 78(1), 39-70.





## Investment in Oil Industry and Renewable Energy: Crowding-in or Crowding-out effect?

Samar S. Mohamed, Alexandria University, +20 1111580845, samar.eco23@gmail.com

### Overview

Seeking to meet the Paris agreement goal of limiting global warming and achieve net-zero emissions by 2050, many countries around the world work on reducing GHG emissions to net zero by 2050. Generally, energy transition a way from fossil fuels to renewable energy is considered pivotal to fulfil net-zero emissions goal and some economies has been working on such transition even before the agreement. This transition led to an approximately ninety-fold increment in global renewable energy installed capacity – as a proxy for investment in the sector- during the period 2000-2021, while world oil refining capacity- as a proxy for investment in oil industry- hardly grew by 25%, during the same period (BP Statistical Review, 2022).

However, these statistics don't mean that expanding renewable investment has driven oil industry growth to slow down, as other factors should be taken in consideration, as oil prices, differences among developing and developed countries in energy consumption patterns, the initial share of each resource in the world total energy production. Besides these factors, recent technological developments in Carbon Capture, Utilization and Storage (CCUS) technology to produce blue and even aqua hydrogen<sup>1</sup>, would be a key to reduce the refining industry's carbon footprint. Another important factor is the continuous advancements in electrical vehicles (EV), which expected to improve EV competitiveness against fuel vehicles as a way to minimize carbon emissions, consequently, it would diminish demand for oil in the transportation sector, which used to mainly depend on oil products.

The aim of this paper is to investigate whether both of renewable energy sources and oil industry may crowd-in or crowd-out each other. Consequently, the analysis takes in account additional variables, besides production capacity in both of renewables (RE) and oil refining industry. Other variables are gross domestic production in constant \$ (GDP), as a proxy of demand for energy; switching rate in electricity generating (SWT) from oil & coal to cleaner resources, i.e. renewables, nuclear energy and natural gas, as a proxy of energy transition, greenhouse gas emissions level (GHG), energy efficiency level (EF), and oil prices (OP).

Accordingly, this study is supposed to contribute to the prevailing works of literature by analysing and measuring the relationship between oil as a fossil fuel and renewables from investment scope rather than the consumption one, taking in account the potential role of oil prices role, and recent technological advancements in VE and CCUS. Another contribution is the comparative analysis of the investigated relation between developing and developed economies.

This paper is organized as follows: a review of literature on the study's topic is provided in section 2, methodology and data are described in section 3, econometric results are presented in section 4. Section 5 discusses empirical findings. Finally, conclusions and policy recommendations are proposed in section 6.

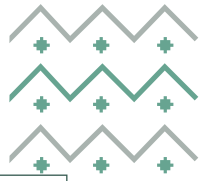
### Methods

In this study two panel models are employed, the first to examine the impact of investing in oil sector on investing in RE, the second model examines the vice-versa relationship. Each model is applied on two panel sets, developed and developing economies, selected countries are chosen based on two criteria: energy total consumption, and energy production capacity, as the chosen countries are considered among the world's top economies in both criteria, and each panel set includes 10 countries. Models are estimated on annual basis, covering the period from 2000 to 2021, in a log-log form.

Stationarity tests are conducted to determine the variables integration orders, results show that variables are integrated in different orders-i.e. I(0) and I(1) - therefor, ARDL cointegration approach introduced by (Pesaran et al., 2001) is the most appropriate approach. The coefficient of the error correction term is negative and significant in the two models, and for each panel set, thus, a long-run relationship between variables is existing. In addition, a modified version of Granger causality approach proposed by Toda & Yamamoto (1995) is applied to investigate causality between variables.

<sup>1</sup> Aqua hydrogen is a new method to extract hydrogen from both conventional and shale oil, the extracted form of hydrogen doesn't emit CO<sub>2</sub>, similar to green hydrogen, but at lower costs (Yu et al., 2021)





## Results

For the first model, long-run estimates emphasise the negative impact of investing in oil industry on investing in RE sector, for both panel sets. Yet, the effect on RE sector in developing countries is larger than the effect in the other group. In addition, short-run coefficients vary among oil importing and oil exporting countries, especially in the developing countries panel set. Other significant variables in this model are OP and GHG, both are positively influence RE in both panel sets- except for OP in developing countries- noticing that GHG in developed countries model, has the greatest impact on RE compared to other variables. On the other hand, SWT has a positive significant impact in the developed countries panel set, while it has a tiny impact in the other set. Other variables – EF & GDP- show insignificant effects in both panel sets. Error correction term value indicates that the speed of adjustments to long-run equilibrium in developing countries is faster than in the developed.

For the second model, while renewable sector significantly affected oil industry in both panel sets, a crucial difference noticed between results, as RE negatively affect investing in oil industry in developed countries, contrary to its effect on oil industry in developing countries. Another worth mentioned difference between the two groups, that OP positively affect oil sector in developing countries, which is contrasting with the insignificant impact in the other panel set. Predictably, SWT has negative, though mild, influence on oil industry in both groups, but it seems to has a bit larger impact in case of developed countries. For EF, results show that it negatively influence oil industry in both panel sets, and has the greatest impact on oil industry investment compared to other variables, in case of developed countries. Finally, Toda-Yamamoto causality test asserted the bi-directional causality from renewable energy to oil industry, in both panel sets, while the causality runs from oil industry to renewable energy in developing countries only.

## Conclusions

The findings suggest that for the world's top energy consuming countries-either developed or developing economies- investment in oil industry causes a crowding-out effect on investing in renewables sector, noting that this effect tends to be larger in oil producing countries in general. On the other hand, investments in renewables sector crowding-out investment in oil industry in developed countries, contrary to its impact in developing countries, where it crowding-in investments in oil industry. This contradiction is due to the difference between the two groups in economic structure and energy consumption patterns, as discussed in the full paper.

The study concludes that switching toward cleaner resources has a significant negative but tiny impact on investment in oil industry, this because such a switch – till now- is mainly affect the electricity generating energy mix, which oil products share is very small, however, the ongoing technological advancement in EV would accelerate demand for clean electricity generating, but at that time the impact on oil industry is expected to be a larger effect, as it would threatens oil products share in transportation sector, the main source of global demand for oil.

Increasing GHG emissions level is considered the dominant factor that accelerates investments in renewables and put pressures on investing in oil sector in developed countries – which mostly are oil importing countries. However, recent developments in CCUS technology would give a life back for fossil fuels, including oil. This technology would be a game changer, especially for low-cost oil producing countries.

The positive effect of oil prices on oil industry investments- in developing countries- may be a warning alarm for energy security in case of relatively low prices, especially that renewables production capabilities still low compared to other fossil fuels, at least in the middle term. This conclusion sheds light again on the crucial role of CCUS technology, which helps to accomplish low-carbon energy transition, as a more practical approach than transiting away from fossil fuels.

## References

- BP, bp Statistical Review of World Energy, 2022, 71<sup>st</sup> edition, available online: <https://www.bp.com/en/global/corporate/energy-economics/statistical-review-of-world-energy.html>
- Pesaran, M.H., Shin, Y. and Smith, R.J., 2001. Bounds testing approaches to the analysis of level relationships. *Journal of applied econometrics*, 16(3), pp.289-326.
- Toda, H. Y and T. Yamamoto (1995). Statistical inferences in vector autoregressions with possibly integrated processes. *Journal of Econometrics*, 66, 225-250.
- Yu, M., Wang, K. and Vredenburg, H., 2021. Insights into low-carbon hydrogen production methods: Green, blue and aqua hydrogen. *International Journal of Hydrogen Energy*, 46(41), pp.21261-21273.





## ***UNLOCKING INDUSTRIAL DEMAND-SIDE FLEXIBILITY FOR THE POWER SYSTEM TROUGH LOCAL GREEN HYDROGEN PRODUCTION: A CASE STUDY IN GERMANY***

Marius Tillmanns, Jan Priesmann, Aaron Praktiknjo  
RWTH Aachen University, Institute for Future Energy Consumer Needs and Behavior (FCN), Chair for Energy System Economics  
+49 241 80 [49873; 49897; 49691]  
[marius.tillmanns; jan.priesmann; apraktiknjo]@eonerc.rwth-aachen.de

### **Overview**

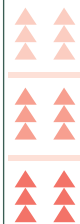
Reducing greenhouse gas emissions in the industry sector is a major challenge for the success of the energy transition. Fossil energy sources for the provision of process heat and for non-energy use are particularly difficult to substitute with renewable energy sources. At the same time, the rising share of fluctuating renewable energies leads to an increasing demand for flexibility in the power system in order to ensure security of electricity supply and grid stability as well as to create incentives for the further development of renewable energies while limiting curtailment and the costs for grid expansion. Renewably produced hydrogen is set to play a key role in completing the energy transition and essential for the decarbonised energy supply in the industrial sector [1], [2]. Moreover, electrolyzers represent a new source of flexibility for power systems with a high share of renewable energies [3], [4]. Thus, green hydrogen yields the potential of addressing both challenges, the decarbonisation of industry and integrating new flexibilities into the energy system. To tap this potential, it is fundamental to bring together the perspective of the overall energy system at the macro level on the one hand and the business perspective of the companies at the micro level on the other. In order to safeguard existing economic sectors and to create incentives for industry to invest in carbon-neutral technologies and provide demand flexibility for the grid, strategies for decarbonisation and demand-side management in the industrial sector must be evaluated together with the economic viability of business models.

In this paper, we perform a techno-economic analysis of the integration of hydrogen in the German industry sector. We evaluate the technical, economic and regulatory potentials and limitations of electrolytically generated hydrogen utilisation (power-to-gas, P2G) in an exemplary case study at an industrial site. Our analysis uses production data covering demands for electricity and process heat as well as material consumption at the site. We consider different regulatory frameworks for grid charges and distinguish three scenarios for the targeted level of decarbonisation. We analyse in which scenarios the integration of hydrogen into the local process chain is economically viable and in which scenarios subsidies are required. In particular, we assess the current regulatory framework and examine to what extent it has an impact on the profitability of business models at the micro level. In addition, we analyse how regulations for grid charges have to be designed to incentivise decarbonisation and system-serving behaviour. Our results suggest that regulations concerning grid fees currently have a major effect on the profitability of integrating green hydrogen in the industry sector.

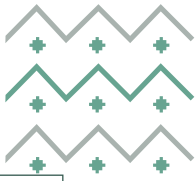
### **Methods**

For the analysis of potentials and limitations of green hydrogen integration in the German industry we develop a techno-economic optimisation model for the local energy system at an industry site that minimises costs for the procurement, generation, storage and utilisation of energy carriers such as electricity, natural gas and hydrogen also considering investment costs. The exogenously given demand for electricity and process heat has to be covered at all times. In order to be able to consider the specific characteristics of the individual process chains in the optimisation, a high temporal resolution is required.

The optimisation model calculates an overall concept for green hydrogen production and utilisation at an industry site, taking into account technical, economic and regulatory criteria. The focus is on the analysis of the implications of the regulatory framework, especially regarding grid charges, the technical design of hydrogen production and use, as well as the evaluation of the integration of further system components such as large hydrogen or battery storage that add flexibility potential for the smoothing of peak loads and load shifting. In addition to potentials from local hydrogen production at the site (onsite), the technical concepts considered also include the option of possible external hydrogen production at a nearby wind farm (offsite) as well as the option of a connection to a national or European hydrogen backbone.







Different scenarios are designed representing different targets for the decarbonisation of the industrial site. While no exogenous targets for emission reduction are set in the baseline scenario, a 30% reduction of carbon emissions is assumed in the emission reduction scenario and a fully decarbonised production in the green production scenario. Since investments in electrolysers and in the adaptation of processes and production technologies are long-term investments and the parameters of our model, such as energy prices, are subject to uncertainty, we perform a sensitivity analysis to determine the sensitivity of our optimisation results to price changes. We apply and test the model in a case study at a steel mill site. For this, we use production data on the energy and material demand of the processes at the site.

## Results

Our results indicate that the regulatory framework, in particular the regulation of grid charges, is a decisive factor for the profitability of the production and use of green hydrogen in German industry. In the baseline scenario green hydrogen use is not cost-efficient for the industry site as prices for green hydrogen are relatively high in comparison to natural gas prices. In the emission reduction scenario and in the green production scenario with a exogenously given emission reduction target of 30%, respectively 100%, the local production and use of green hydrogen is cost-efficient due to potential savings regarding grid charges.

However, the current regulatory design for grid charges does not incentivise the provision of flexibility to the power system. Rather, the regulations promote uniform electricity demand instead of flexible demand depending on the feed-in from renewables or on system-wide peak load hours.

## Conclusions

Sector coupling in industry will play an important role in decarbonising the industrial sector. In addition to the electrification of industrial processes, the integration of hydrogen offers the potential to decarbonise processes that cannot be electrified and, at the same time, to make the electricity demand of an industrial site more flexible by decoupling the electricity drawn from the power grid and the electricity demand from the process chain at the site. Especially in industry sectors where industrial demand-side management is difficult to implement due to specific process characteristics, electrolysers can increase the flexibility of industrial electricity demand.

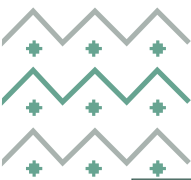
However, our case study suggests that the investment is not cost-efficient for the exemplary industry site under the current regulatory framework. Subsidies or an adjustment of levies, fees and taxes are needed to support companies in the decarbonisation of industrial processes. With regard to the flexibility potential of electrolysers and local green hydrogen production, this case study indicates that the current regulation of grid charges sets the wrong incentives and rewards steady rather than flexible electricity demand. Thus, the current regulatory design in Germany creates incentives for peak-shaving of peak demand at the site, but does not incentivise adjusting demand to the availability of intermittent renewables or system-wide peak load hours. In order to tap the potentials of the production and use of green hydrogen in industry, it is therefore necessary to adapt the regulatory design with a view to the requirements of a future decarbonised energy system.

Our modelling approach can be transferred to other energy-intensive industries such as the chemical industry. As the different industry sectors and sites are characterised by individual process designs and energy demand patterns, they may offer different potentials of providing flexibility, leading to different implications regarding the economic viability of integrating green hydrogen.

## References

- [1] Federal Ministry for Economic Affairs and Energy (2020). The National Hydrogen Strategy. Retrieved from <https://www.bmwi.de/Redaktion/EN/Publikationen/Energie/the-national-hydrogen-strategy.html>. 18.04.2022.
- [2] European Commission (2020). Hydrogen Strategy for a Climate-neutral Europe. Retrieved from [https://ec.europa.eu/energy/sites/ener/files/hydrogen\\_strategy.pdf](https://ec.europa.eu/energy/sites/ener/files/hydrogen_strategy.pdf). 18.04.2022.
- [3] Ruhnau, O. (2022). How flexible electricity demand stabilizes wind and solar market values: The case of hydrogen electrolysers. *Applied Energy*, 307, 118194.
- [4] Rabiee, A., Keane, A., Soroudi, A. (2021). Green hydrogen: A new flexibility source for security constrained scheduling of power systems with renewable energies. *International Journal of Hydrogen Energy*, 46(37), 19270.





## *The dynamic fluctuations in oil prices: The role of precious metals, oil production, and uncertainty under the NARDL framework*

Amjad M. Kisswani, Department of Workforce Development and Organizational Leadership, University of Nevada-Las Vegas, Nevada, USA- Tel. (+702) 338-8448. [ajkisswani@gmail.com](mailto:ajkisswani@gmail.com)

Khalid M. Kisswani, Department of Economics and Finance - Gulf University for Science and Technology-P.O. Box 7207, Hawally, 32093, Kuwait-Tel. (+965) 2530-7339, [kisswani.k@gust.edu.kw](mailto:kisswani.k@gust.edu.kw)

Mohamed M. Moustafa, Department of Business administration - Gulf University for Science and Technology-P.O. Box 7207, Hawally, 32093, Kuwait-Tel. (+965) 2530-7331. [moustafa.m@gust.edu.kw](mailto:moustafa.m@gust.edu.kw)

### Overview

Oil price fluctuations generated a lot of attention among academics, practitioners, and policymakers since the first oil price shock in 1973. Ever since, oil prices were thought to be more volatile than the prices of other goods seeing that the oil markets went through various periods of boom and bust (Regnier, 2007). The literature has evolved drastically on the reasons and sources of oil price fluctuations. The empirical work identified a variety of causes that led to these fluctuations. For example, the fluctuations in the worldwide demand for oil, disturbances and interruptions in supply, political unrests around the world, and speculative purposes (Caldara et al., 2019). Over the last 40 years, economists made substantial efforts in studying the oil price fluctuations following the novel work of Hamilton (1983) who showed the adverse effect of oil prices on output growth. The Energy Information Administration (EIA), in their 2006 report, shows that the worldwide economic growth continues to be substantially associated with oil prices (IEA, 2006). On the other hand, a strand of literature suggests an asymmetric association between oil price fluctuations and the macroeconomy (e.g.: Mork, 1989; Mory, 1993; Ferderer, 1996). On the whole, the oil price fluctuations are perceived to have vital macroeconomic effects for both oil-importers and oil-exporters (see for example: Hamilton, 1996; Stern and Cleveland, 2004; Jiménez-Rodríguez and Sánchez, 2005; Rafiq et al., 2009; Kisswani and Kisswani, 2019; Kisswani, 2021a).

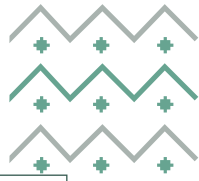
The argument that supply and demand shocks being responsible for oil price fluctuations has been long debated among academics and practitioners, due to the different models employed and variety of time series data used. For example, Barsky and Kilian (2002), Kilian (2009) and Kilian and Murphy (2014) argue that most historical oil price fluctuations are attributed to demand shocks not to supply shocks. On the other hand, Hamilton (2009), Kaufmann (2011), Baumeister and Hamilton (2019) and Caldara et al. (2019) argue that oil price fluctuations are more to be supply-side driven, although demand and supply shocks are both equally significant in enlightening the fluctuations. Hamilton (2009) points out that speculation on the oil market can another cause of the oil price fluctuations. On the other hand, investors consider oil as a key investment tool, for that reason fluctuations in oil prices are believed to affect other investment means such as the precious metals (gold and silver) given the connection between the financial markets and economic growth (Yildirim et al., 2020). Zhang and Wei (2010) found that oil prices and the gold prices are positivity correlated. Sari et al. (2011) find that prices of gold and silver lead oil prices, since oil and precious metals are considered tools for hedging by traders and investors. Kang et al. (2017) documented a bidirectional spillover between oil prices and the prices of gold and silver. In addition, they show that both gold and silver are information transmitters to oil future market. Berdin et al. (2015), Lucey and Li (2015), and Salisu et al. (2020), among others, find precious metals are useful hedge against volatile oil prices.

The effects of uncertainty on oil markets is an additional source that may contribute to oil price volatility. When uncertainty increases, financial traders try to hedge against this, causing negative impact on prices of future oil contracts, in addition to increasing uncertainty regarding future supply and demand in the oil markets, triggering more price fluctuations (Cheng et al., 2015; Bakas and Triantafyllou, 2018). Kilian (2009) discusses the effect of uncertainty on the oil market. Degiannakis et al. (2014) argue that uncertainty possibly feeds into oil price fluctuations. Aloui et al. (2016) show that, throughout particular periods of time, uncertainty affects oil returns positively. Lyu et al. (2021) find that economic uncertainty affects crude oil price returns negatively. Still, other empirical work finds no effect of uncertainty on oil price fluctuations (e.g. Reboredo and Salah Uddin, 2016).

### Methods

The variation in the outcomes of the empirical work may be due to the specification of the estimated models. Interestingly, the bulk of empirical work assumed a linear (symmetric) association and did not consider the asymmetric effect on oil price fluctuations, whereas Hamilton (2003) argues that economic variables behave in a nonlinear (asymmetric) fashion over time, and as a result ignoring asymmetric behavior may cause deceptive and misleading interpretations. In this regard, this paper sheds light on the drivers of the fluctuations of West Texas Intermediate (WTI hereafter) oil price by highlighting the roles of prices of precious metals (gold and silver), oil production (OPEC and Non-OPEC), and uncertainty (measured by Economic Policy Uncertainty, EPU hereafter), by applying the novel asymmetric time-varying model of Shin et al. (2014); nonlinear autoregressive distributed lags model (NARDL). To





date, and to the best of our knowledge, no or limited work has considered the presence of nonlinearity in examining oil price fluctuations.<sup>1</sup> In view of that, in this paper we tackle the nonlinearity (asymmetry) through employing the NARDL model, which has shown great power in capturing the asymmetric effects in both the short- and long-run, and has been adopted in various empirical studies. There are noticeable advantages of utilizing the NARDL model. First, it allows examining the long-run relationship irrespective of whether the involved variables are  $I(0)$  or  $I(1)$  or a mixture of both. Second, it is estimated by OLS and allows for detecting the asymmetric short- and long-run effects. Third, it introduces the long- and short-run nonlinearities via decomposing any explanatory variable into positive and negative partial sums. Forth, it allows explanatory variables to take different lag order which helps in avoiding the endogeneity problem. Finally, NARDL model can be employed efficiently in the case of small sample size. In sum, the NARDL model is an appropriate methodology to provide significant insights about the asymmetric econometric relationships.

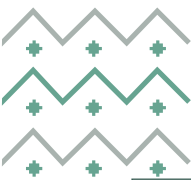
### Results

The empirical findings show a significant asymmetric cointegration between oil prices and its explanatory variables. The long-run statistics of the NARDL model provide evidence of an asymmetric effect of the explanatory variables (prices of gold and silver, and oil production, and EPU) on oil prices, denoting that the effect of the positive changes (increase) is different than the negative changes (decrease). On the other hand, short-run asymmetry was found to be significant for silver price and oil production only. The employed diagnostics tests show that the NARDL findings are stable. Before undertaking the NARDL investigation, we carried out the non-linearity assessment of Broock et al. (1996). The results revealed that all the engaged variables show non-linearity behavior, offering sound verification for utilizing the NARDL approach for the asymmetric assessment. Finally, the Toda and Yamamoto (1995) causality test shows heterogeneous findings.

---

<sup>1</sup> KISSWANI (2021b) studied the asymmetric effects of three measures of uncertainty on oil price fluctuations





## Nuclear Bias in Energy Scenarios – A Review and Results from an in-depth Analysis of Long-Term Decarbonisation Scenarios

Jens Weibezahn, Copenhagen School of Energy Infrastructure & TU Berlin, jew.eco@cbs.dk  
Björn Steigerwald, Universität of Technology Berlin, bs@wip.tu-berlin.de  
Christian Breyer, Lappeenranta University of Technology, christian.breyer@lut.fi  
Christian von Hirschhausen, Universität of Technology Berlin, cvh@wip.tu-berlin.de

### Overview

In the context of decarbonisation, long-term energy scenarios play an important role to provide guidance to industry and policymakers, including potential futures and pathways. However, energy scenarios are themselves subject to political and industry influence, such that assumptions – and hence results – are not “objective” but rely on specific views and perceptions on the future. The debate about the future energy systems, is often characterized by biases and belief systems rooted in broader public perceptions as opposed to expert insights and data (Midttun and Baumgartner 1986; Krey et al. 2019; Bloomfield et al. 2021). Since the beginning of long-term energy planning, nuclear power has played a particularly important role, both due to expected technical progress, and the difference between expected cost reductions and real cost developments. Thus, energy scenarios of the 1960s counted on fast breeder reactors to deliver energy “too cheap to meter” (Strauss 1954) in what Seaborg (1970) called the “plutonium economy”. Another wave of technical optimism occurred in the 1980s (mainly in Europe), where the advent of a new technology generation was expected, that would lead to a significant increase in the share of nuclear power in electricity generation (Häfele 1981). At the moment, another wave of technological forecasting expecting “advanced nuclear” to play a major role in decarbonised energy systems is becoming popular (Duan et al. 2022). However, a recent paper from the Integrated Assessment Modelling (IAM) community and scenarios with updated cost assumptions of renewables, in particular for solar photovoltaics and energy system integration costs, point in the opposite direction, i.e. that due to high costs, nuclear power is phased out in the coming decades (Jacobson et al. 2019; Löffler et al. 2017; Luderer et al. 2021; Pursiheimo, Holttinen, and Koljonen 2019; Teske et al. 2021; Bogdanov et al. 2021).

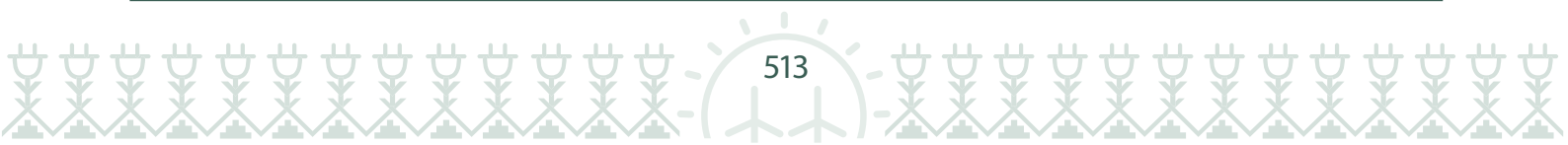
### Methods

We screen 409 Scenarios of 24 Integrated Assessment models based on the IAMC 1.5°C Scenario Explorer (Huppmann, Daniel et al. 2019) and 822 Scenarios of 84 Integrated Assessment models based on the AR6 Scenarios Database hosted by IIASA (Byers, Edward et al. 2022) to their assumptions on the development of nuclear power, and other elements of the energy system, and how these translate into relative and absolute contributions of nuclear power in long-term decarbonisation scenarios. We provide an in-depth analysis of those different energy scenarios based on the IAMC 1.5°C Scenario Explorer (Huppmann, Daniel et al. 2019) and data with regards to their pathways in the share of nuclear power over time and of the AR6 Scenarios. We cluster these scenarios and compare their underlying models as well as assumptions mainly with regard to CAPEX. In addition, these results are compared with energy scenarios of major international institutions and independent research teams publishing global scenarios.

### Results and Conclusions

We find that in the universe of ambitious long-term decarbonisation scenarios, two groups can be clearly identified: (1) Some models conclude a rising share of nuclear, implying a steep increase in absolute power plant capacities; this group includes international organisations (IAEA 2020), also the IPCC (2018) with its IAM scenarios and the IEA (IEA 2021a) with their Net Zero by 2050 Scenarios with the highest nuclear projection since IEA history; while (2) other models consistently find a decreasing share of nuclear power, leading to very high shares of renewables. Figure 1 shows that the former group forecasts a slightly rising relative share of nuclear, which – given steeply rising electricity demand – implies a steep increase in nuclear power plant capacities. On the contrary, the decline of nuclear in the other group is linear until 2050/2060. Interestingly, some scenarios forecast a “rebound effect” after 2060, whereas in the larger subgroup nuclear phases out by 2060.

At present, we are analysing the first group of scenarios with respect to their assumptions. In general, assumptions of cost digression for nuclear are very optimistic, whereas they are rather pessimistic on renewables costs. Nuclear is often modelled as a baseload technology because flexibility options for renewables-based systems are underestimated. Also, we find an inconsistency in the International Energy Agency’s (IEA) annual World Energy Outlook (WEO): The highest value scenario for nuclear power is estimated by the current Net Zero Emissions scenario (NZE) of the IEA, which at the same time confirms that nuclear power is the most expensive way to provide electricity (IEA 2021b), which is confirmed by independent market analysts (Lazard 2021). We conclude the need for a critical assessment of







long-term scenarios, both with respect to cost assumptions of nuclear power and other variables, and the modelling of a largely decarbonised energy system.

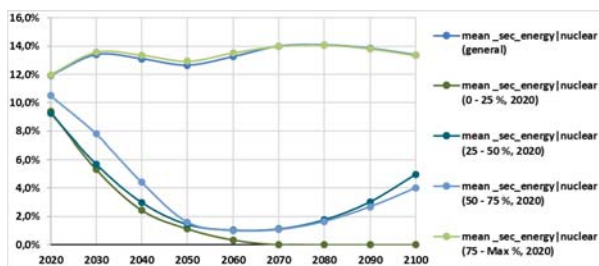
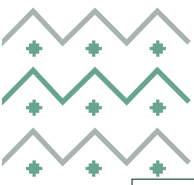


Figure 1: Preliminary explorative – analysis of the development of the share of nuclear energy in total net energy production of IAMC 1.5 scenarios (Base year 2050, 10 yr. – resolution).

## References

- Bloomfield, H.C., D.J. Brayshaw, A. Troccoli, C.M. Goodess, M. De Felice, L. Dubus, P.E. Bett, and Y.-M. Saint-Drenan. 2021. "Quantifying the Sensitivity of European Power Systems to Energy Scenarios and Climate Change Projections." *Renewable Energy* 164 (February): 1062–75. <https://doi.org/10.1016/j.renene.2020.09.125>.
- Bogdanov, Dmitrii, Manish Ram, Arman Aghahosseini, Ashish Gulagi, Ayobami Solomon Oyewo, Michael Child, Upeksha Caldera, et al. 2021. "Low-Cost Renewable Electricity as the Key Driver of the Global Energy Transition towards Sustainability." *Energy* 227 (July): 120467. <https://doi.org/10.1016/j.energy.2021.120467>.
- Byers, Edward, Krey, Volker, Kriegler, Elmar, Riahi, Keywan, Schaeffer, Roberto, Kikstra, Jarmo, Lamboll, Robin, et al. 2022. "AR6 Scenarios Database." Zenodo. <https://doi.org/10.5281/ZENODO.5886912>.
- Duan, Lei, Robert Petroski, Lowell Wood, and Ken Caldeira. 2022. "Stylized Least-Cost Analysis of Flexible Nuclear Power in Deeply Decarbonized Electricity Systems Considering Wind and Solar Resources Worldwide." *Nature Energy*, February, 1–10. <https://doi.org/10.1038/s41560-022-00979-x>.
- Häfele, Wolfgang. 1981. *Energy in a Finite World: A Global Systems Analysis (Volume 2)*. Cambridge, MA, USA: Ballinger.
- Huppmann, Daniel, Kriegler, Elmar, Krey, Volker, Riahi, Keywan, Rogelj, Joeri, Calvin, Katherine, Humpenoeder, Florian, et al. 2019. "IAMC 1.5°C Scenario Explorer and Data Hosted by IIASA." Zenodo. <https://doi.org/10.5281/ZENODO.3363345>.
- IAEA. 2020. "Climate Change and the Role of Nuclear Power." <https://www.iaea.org/publications/14763/climate-change-and-the-role-of-nuclear-power>.
- IEA. 2021a. "Net Zero by 2050." Paris. <https://www.iea.org/reports/net-zero-by-2050>.
- . 2021b. "World Energy Outlook 2021." Paris, France: International Energy Agency. <https://doi.org/10.1787/14fcb638-en>.
- IPCC. 2018. "Global Warming of 1.5°C. An IPCC Special Report on the Impacts of Global Warming of 1.5°C above Pre-Industrial Levels and Related Global Greenhouse Gas Emission Pathways, in the Context of Strengthening the Global Response to the Threat of Climate Change, Sustainable Development, and Efforts to Eradicate Poverty." New York, NY, USA: IPCC. <https://www.ipcc.ch/sr15/download/>.
- Jacobson, Mark Z., Mark A. Delucchi, Mary A. Cameron, Stephen J. Coughlin, Catherine A. Hay, Indu Priya Manogaran, Yanbo Shu, and Anna-Katharina von Krauland. 2019. "Impacts of Green New Deal Energy Plans on Grid Stability, Costs, Jobs, Health, and Climate in 143 Countries." *One Earth* 1 (4): 449–63. <https://doi.org/10.1016/j.oneear.2019.12.003>.
- Krey, Volker, Fei Guo, Peter Kolp, Wenji Zhou, Roberto Schaeffer, Aayushi Awasthy, Christoph Bertram, et al. 2019. "Looking under the Hood: A Comparison of Techno-Economic Assumptions across National and Global Integrated Assessment Models." *Energy* 172 (April): 1254–67. <https://doi.org/10.1016/j.energy.2018.12.131>.
- Lazard. 2021. "Lazard's Levelized Cost of Energy Analysis - Version 15.0." 15.0. LAZARD'S Levelized Costs of Energy Analysis. New York. <https://www.lazard.com/media/451881/lazards-levelized-cost-of-energy-version-150-vf.pdf>.
- Löffler, Konstantin, Karlo Hainsch, Thorsten Burandt, Pao-Yu Oei, Claudia Kemfert, and Christian von Hirschhausen. 2017. "Designing a Model for the Global Energy System—GENESYS-MOD: An Application of the Open-Source Energy Modeling System (OSEMOSYS)." *Energies* 10 (10): 1468. <https://doi.org/10.3390/en10101468>.
- Luderer, Gunnar, Silvia Madeddu, Leon Merfort, Falko Ueckerdt, Michaja Pehl, Robert Pietzcker, Marianna Rottoli, et al. 2021. "Impact of Declining Renewable Energy Costs on Electrification in Low-Emission Scenarios." *Nature Energy*, November. <https://doi.org/10.1038/s41560-021-00937-z>.
- Midttun, Atle, and Thomas Baumgartner. 1986. "Negotiating Energy Futures: The Politics of Energy Forecasting." *Energy Policy* 14 (3): 219–41. [https://doi.org/10.1016/0301-4215\(86\)90145-X](https://doi.org/10.1016/0301-4215(86)90145-X).
- Pursiheimo, Esa, Hannele Holttinen, and Tiina Koljonen. 2019. "Inter-Sectoral Effects of High Renewable Energy Share in Global Energy System." *Renewable Energy* 136 (June): 1119–29. <https://doi.org/10.1016/j.renene.2018.09.082>.
- Seaborg, Glenn T. 1970. "The Plutonium Economy of the Future." Santa Fe, New Mexico. <http://fissilematerials.org/library/aec70.pdf>.
- Strauss, Lewis. 1954. "Remarks Prepared by Lewis L. Strauss, Chairman, United States Atomic Energy Commission, For Delivery at the Founders' Day Dinner, National Association of Science Writers, on Thursday, September 16, 1954, New York, New York." Washington D.C.: Atomic Energy Commission. <https://www.nrc.gov/docs/ML1613/ML16131A120.pdf>.
- Teske, Sven, Thomas Pregger, Sonja Simon, Tobias Naegler, Johannes Pagenkopf, Özcan Deniz, Bent van den Adel, Kate Dooley, and Malte Meinshausen. 2021. "It Is Still Possible to Achieve the Paris Climate Agreement: Regional, Sectoral, and Land-Use Pathways." *Energies* 14 (8): 2103. <https://doi.org/10.3390/en14082103>.





## Geospatial agent-based modelling of household long-term energy transition in the MEA region using high-resolution gridded data and the MUSE-RASA model

[Diego Moya, Imperial College London and Technical University of Ambato, 593 032 8849687, da.moya@imperial.ac.uk]  
[Sara Giarola, Imperial College London and Polytechnic University of Milan, +44 7721 490582, s.giarola10@imperial.ac.uk]  
[Adam Hawkes, Imperial College London, +44 (0)20 7594 9300, a.hawkes@imperial.ac.uk]

### Overview

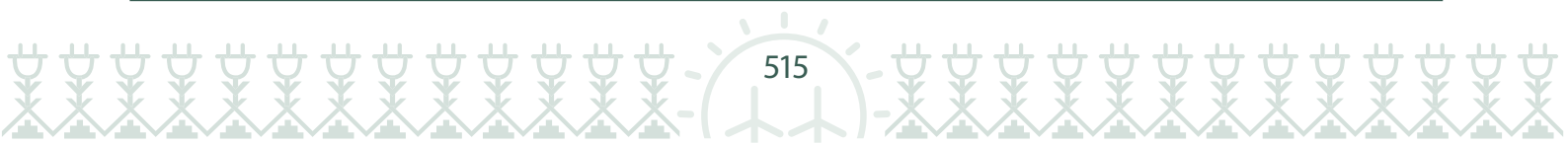
The Residential Sector (RS) is a sector where most of the Neoclassical Economic Theory principles about the dimension representation may fail. The RS is responsible for consumption and management of energy in residential buildings [1] and contain electricity, heat and cold suppliers [2]. The RS might account for 25% and up to 30% of the total energy consumption of a nation. This share depends on a range of heterogeneous and diversity factors as the socioeconomic dimension of consumers, weather conditions and cultural characteristics that evolve in space and time [3]. Most importantly, heating (space heating and water heating) and cooling (space cooling) can account for up to 80% of all the residential energy and depends on human behaviour, social structures and income levels. And related global greenhouse gas emissions represent 17% of global emissions [5]. Thus, the assessment of the human dimension, considering other theory fundamentals for the sustainable transition of this sector is key to meet mid-century net-zero emission targets.

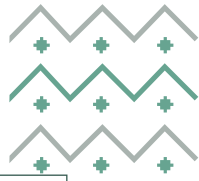
### Methods

To overcome the limitations of the representative homogenous hyper-rational agent in traditional models based on Neoclassical economics, the representation of the human dimension in climate-energy-economy models requires the use of empirical, historical, and analytical data from other schools of economic thought. The framework presented here is based on assumptions from Anwar Shaikh's Theory of Real Competition. Geospatial big data analytics (combination of Geographical Information Systems, GIS, and Big Data Analytics) and agent-based modelling (ABM) tools present a potential opportunity to introduce realism, as Shaikh states, in the analysis by representing the complexities of agent's heterogeneous shaping structures and diverse shaping attributes.

This article presents the framework of the novel MUSE (ModUlar energy system Simulation Environment) Residential Spatially-resolved and temporal-explicit Agents (RASA): MUSE-RASA model, a Geospatial Based Modelling Framework based on Shaikh's Theory of Real Competition. This enhanced model has been developed to assess the long-term transition of the Climate-energy-economy system with a focus on the residential sector globally with a particular focus on the MEA region (Kuwait, Lebanon, Oman, Qatar, Saudi Arabia, Syria, Arab Emirates, Yemen, Bahrain, Islamic Republic of Iran, Iraq, Jordan) and its impact on reaching the mid-century net-zero target.

The MUSE-RASA framework uses geospatial big data analytics to capture realism into the modelling approach. To do this, spatial agents have been defined by the characterisation and parametrisation of five components. The agent components are heterogeneity, diversity, evolution, decision-making and exogenous constraints.





term transitions. Traditional models have limited their consideration of the human dimension to the perfectionist theoretical notion of a representative homogenous agent with infinite perfect foresight and hyper-rational expectations.

Figure 1 illustrates the interactions of the five components of the MUSE-RASA model to abstract the real world into a micro-environment and a macro-environment of the simulation process. This simulation produces global metrics that serve to analyse the transition and to design policy recommendations. The MUSE-RASA modelling approach improves on traditional models by representing the complexities of agent's heterogeneous structures, diversity and evolving attributes to introduce more realism into the analysis when considering empirical, historical, and analytical evidence, which is in line with post-Keynesian and Marxist economic theory foundations (Heterodox schools of economic thought). The MUSE-RASA model is therefore a more realistic IAM that integrates GIS-based and ABM approaches for the global assessment of the residential sector transition, considering heterogeneous and diverse agents that evolve in space and time under a range of endogenous and exogenous constraints.

## Results

Results are presented for a single representative hyper rational agent in Figure 2 and for eleven socioeconomic agents in Figure 3. These results illustrate the difference between considering hyper rational representative agents and when considering the actual characteristics of consumers towards the net zero emission target in the region under study.

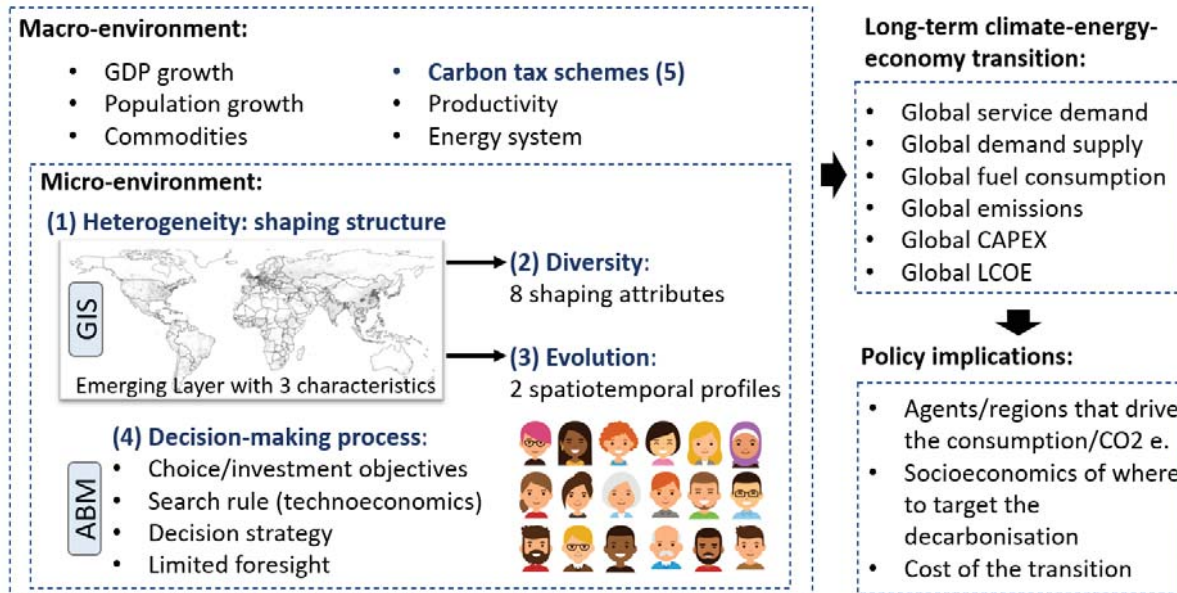
## Conclusions

Results show the relevance of representing agent disaggregation capturing a range of attributes when assessing the long-term sustainable transition of the residential sector in the MEA region. The agent heterogeneity, diversity, evolution, decision-making process, and exogenous constraints have been captured to define eleven agents. For each agent in the region, five outputs of the MUSE-RASA model have been produced: service demand with a focus on space heating, heating supply by technologies, fuel and electricity consumption, emissions, and transition costs. Recommendations for energy policy design can be described with reference to four aspects: household budget limitations, quantification of the total demand, carbon tax schemes and heat density restriction. Considering these aspects in policy design will introduce realism in the evidence base, thus supporting most robust policy design and suprasing neoclassical-based model assumptions.

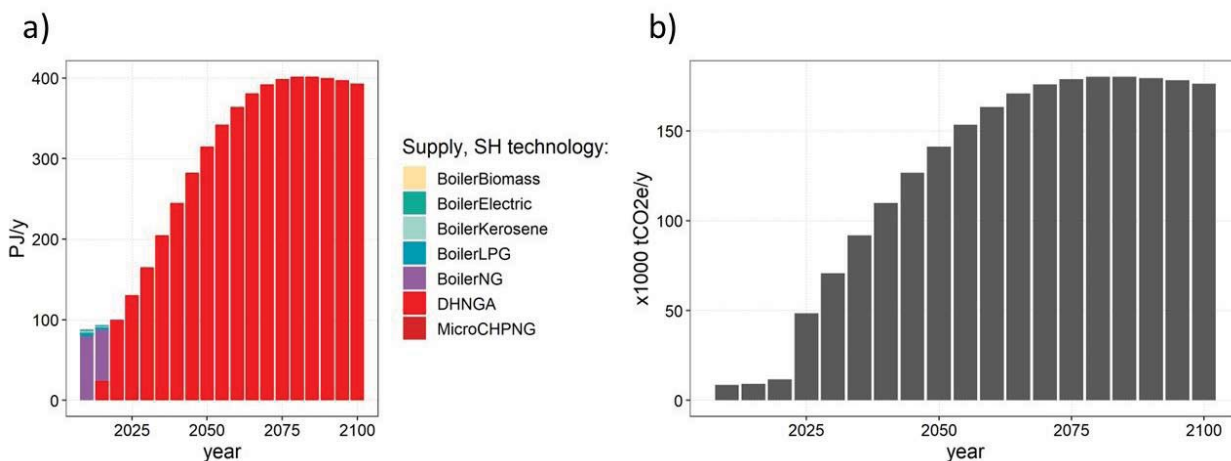




**Figures:**

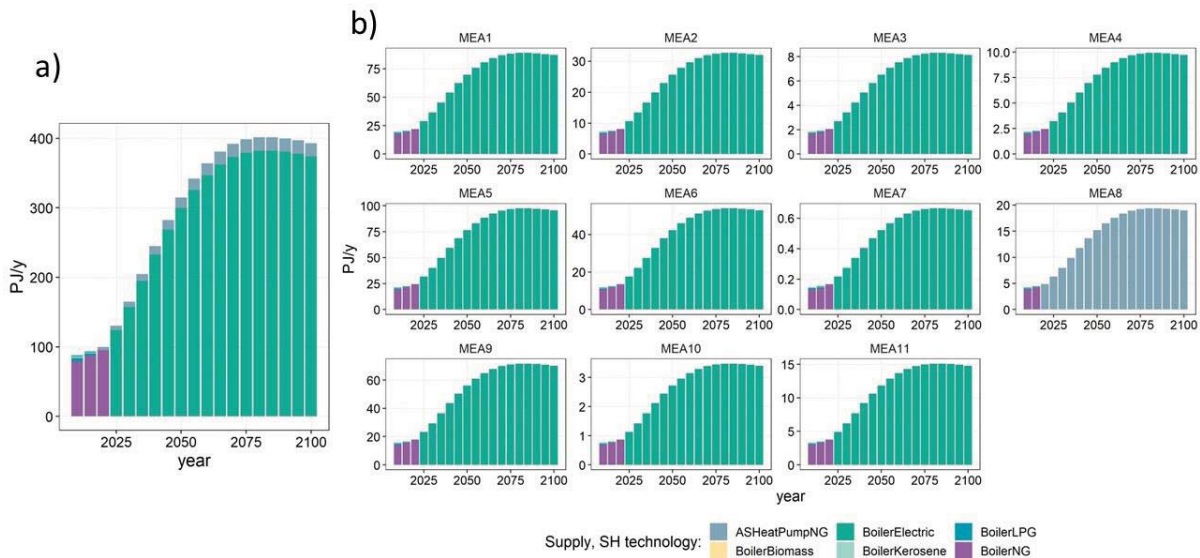


**Figure 1: Abstracting from the real world to the MUSE-RASA model, outcomes, and implications. The five components of the geospatial Agent-Based Modelling Framework are identified in the micro- and macro-environment of the MUSE-RASA model. The model outcomes and policy implications are also illustrated in the MUSE-RASA environment.**



**Figure 2: Modelling of the supply of space heating services in the MEA region during winter and cooler periods. These results are based on the hyper rational assumption of a representative agent for the whole region. a) Region-wide supply in the long-term; b) Region-wide of emissions in the long-term until the end of the century.**

Energy Modeling



**Figure 3: Modelling of the supply of space heating services in the MEA region during winter and cooler periods under a GIS-ABM approach. These results are based on eleven socioeconomic agents for the whole region.**

### References

- [1] V. S. K. V. Harish and A. Kumar, "A review on modeling and simulation of building energy systems," *Renewable and Sustainable Energy Reviews*, vol. 56, no. Supplement C, pp. 1272-1292, 2016/04/01/ 2016, doi: <https://doi.org/10.1016/j.rser.2015.12.040>.
- [2] F. Bünning, R. Sangi, and D. Müller, "A Modelica library for the agent-based control of building energy systems," *Applied Energy*, vol. 193, no. Supplement C, pp. 52-59, 2017/05/01/ 2017, doi: <https://doi.org/10.1016/j.apenergy.2017.01.053>.
- [3] J. Ma and J. C. P. Cheng, "Estimation of the building energy use intensity in the urban scale by integrating GIS and big data technology," *Applied Energy*, vol. 183, no. Supplement C, pp. 182-192, 2016/12/01/ 2016, doi: <https://doi.org/10.1016/j.apenergy.2016.08.079>.
- [4] P.-H. Li, I. Keppo, and N. Strachan, "Incorporating homeowners' preferences of heating technologies in the UK TIMES model," *Energy*, vol. 148, pp. 716-727, 2018/04/01/ 2018, doi: <https://doi.org/10.1016/j.energy.2018.01.150>.
- [5] IEA. "Greenhouse Gas Emissions from Energy: Overview " <https://www.iea.org/reports/greenhouse-gas-emissions-from-energy-overview> (accessed 25 Dec, 2021).



## PREVENTIVE APPROACH IN OPTIMISING ELECTRICITY MARKET STRUCTURE USING MARKET POWER MITIGATION AND FORWARD CONTRACT

[Dzikri Firmansyah Hakam Ph.D, School of Business and Management ITB, dzikri.hakam@sbm-itb.ac.id]

### Overview

This paper examines the law and economics of imperfect competition in electricity markets. Market power, defined as the ability to raise prices profitably above the competitive level, is a significant issue in the aftermath of electricity market restructuring (Hakam 2018). In the process of regulatory reform and the development of competitive electricity markets, it appears desirable and practical to establish an efficient number of competitor generating companies. Using a purpose-built algorithm (Hakam and Macatangay 2018), one approach is to optimize the configuration of generating companies ex-ante (before restructuring) rather than ex-post. A simulation of an electric power system takes into account not only multi-plant mergers of generating companies subject to a regulatory measure of market power (i.e. the residual supply index) (Sheffrin 2002, 2001; Rahimi and Sheffrin 2003), but also direct current load flow.

### Methods

We used a nodal pricing (perfect competition) (Schweppe et al. 1988; Hakam et al. 2019) and Cournot model in a large market simulation, namely the IEEE 30 bus electricity market with 13 GenCos. Using the Residual Supply Index to mitigate market power, this study provides an ex-ante solution for creating optimal electricity market structure through recursive optimisation.

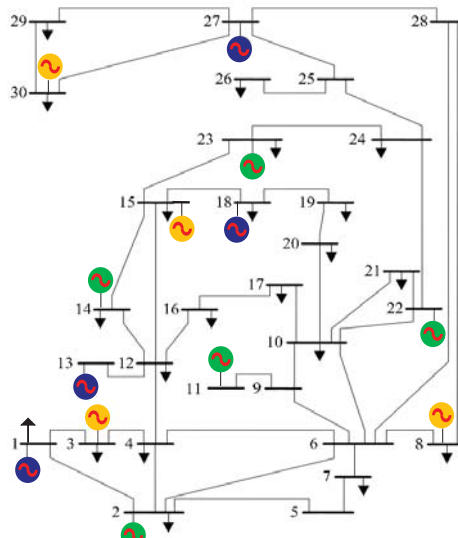


Figure 1. IEEE 30 bus power system

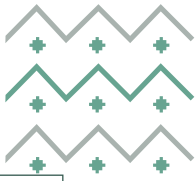
### Results

According to numerical simulation, the efficient market structure in constrained nodal pricing is six players with a unique mix of generation technology (base, intermediate and peak GenCos).

The optimal number of players in the Cournot case study is five, with a slightly different mix than in the baseline scenario. Forward contracts reduce market power and provide leverage for the creation of an optimal market structure with fewer market participants. As a result, this study discovered the minimum contract coverage required to make the market structure reasonably competitive. Based on the results of this simulation, we believe that forward contracts and a balanced mix of generation technology in successor companies will help to mitigate market power and create an optimal market structure.







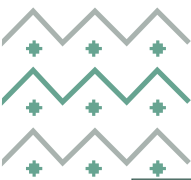
## Conclusions

This study extends the application of forward contract in Cournot model e.g. (Allaz and Vila 1993) and (Willems, Rumiantseva, and Weigt 2009) by incorporating RSI as an ex-ante tool for mitigating market power. This study also extends the application of RSI in the contract-Cournot study of (Newbery 2009) by applying forward contract concept in a more complex market structure (i.e. IEEE 30 bus test system) with DC load flow. Furthermore, this paper extend the ex-ante approach of mitigating market power in electricity market restructuring as in (Hakam 2019; Hakam, Wiyono, and Hariyanto 2020) by incorporating forward contract in the analysis.

The contributions of this paper are that, by following the algorithm of (Hakam 2019) we found an efficient number of players and optimal market structure for a large power system. The preventive approach applied in the simulations provides a balanced mix of generation technologies for each GenCo. Market setting a la Cournot (5 players) offers lower player participants compare to the perfect competition setting (6 players). Using forward contract as an instrument to reduce market power, the market regulator could design a four player configuration with optimal contract coverage 26%. The results of this simulation are subject to the assumption and power system characteristic applied. The numerical simulation based on one-shot gaming that could have a different result with dynamic calculation in real time power system.

## References

- Allaz, Blaise, and Jean-Luc Vila. 1993. "Cournot Competition, Forward Markets and Efficiency." *Journal of Economic Theory*. <https://doi.org/10.1006/jeth.1993.1001>.
- Hakam, Dzikri Firmansyah., Evy Haryadi, Harry Indrawan, and Arion Simaremare. 2019. "Economic Valuation of Efficient Pricing : Case Study of Java Bali Power System." *2019 2nd International Conference on High Voltage Engineering and Power Systems (ICHVEPS)*, 80–84.
- Hakam, Dzikri Firmansyah. 2018. "Market Power Modelling in Electricity Market : A Critical Review." *International Journal of Energy Economics and Policy* 8 (5): 347–56.
- . 2019. "Mitigating the Risk of Market Power Abuse in Electricity Sector Restructuring: Evidence from Indonesia." *Utilities Policy* 56 (February 2019): 181–91. <https://doi.org/10.1016/j.jup.2019.01.004>.
- Hakam, Dzikri Firmansyah, and Rafael Emmanuel "Manny" Macatangay. 2018. "Optimising Indonesia's Electricity Market Structure : Evidence of Sumatra and Java-Bali Power System." In *Proceedings of the 19th International Conference on Industrial Technology*. Lyon, France: IEEE.
- Hakam, Dzikri Firmansyah, Sudarso Kaderi Wiyono, and Nanang Hariyanto. 2020. "Competition in Power Generation : Ex-Ante Analysis of Indonesia ' s Electricity Market," 1–20.
- Newbery, David. 2009. "Predicting Market Power in Wholesale Electricity Markets." 0821. Cambridge, UK.
- Rahimi, A, and Anjali Sheffrin. 2003. "Effective Market Monitoring in Deregulated Electricity Markets." *IEEE Transactions on Power Systems* 18 (2): 486–93.
- Schweppe, Fred, Michael Caramanis, Richard Tabors, and Roger Bohn. 1988. *Spot Pricing of Electricity. The Kluwer International Series in Engineering and Computer Science*. 1st ed. Massachusetts: Kluwer Academic Publishers. <https://doi.org/10.1007/978-1-4613-1683-1>.
- Sheffrin, Anjali. 2001. "Critical Actions Necessary for Effective Market Monitoring : Draft Comments of Anjali Sheffrin FERC RTO Workshop, October 19, 2001." California, USA.
- . 2002. "Predicting Market Power Using the Residual Supply Index. Presented to FERC Market Monitoring Workshop December 3-4, 2002." California, USA.
- Willems, Bert, Ina Rumiantseva, and Hannes Weigt. 2009. "Cournot versus Supply Functions: What Does the Data Tell Us?" *Energy Economics* 31 (1): 38–47. <https://doi.org/10.1016/j.eneco.2008.08.004>.



## ***AERO-THERMAL PERFORMANCE INVESTIGATION OF REFRIGERATED TRUCK EQUIPPED WITH PHASE CHANGE MATERIALS ENCAPSULATED IN RECTANGULAR RODS***

M. A. Ben Taher, ETTE, FSTT, Abdelmalek Essaadi University, Tetouan, Morocco, [bentaher.medamine@yahoo.com](mailto:bentaher.medamine@yahoo.com)  
M. Mahdaoui, ETTE, FSTT, Abdelmalek Essaadi University, Tetouan, Morocco, [mmahdaoui@uae.ac.ma](mailto:mmahdaoui@uae.ac.ma)  
T. Kouksou, SIAME, UPPA, France, [tarik.kouksou@univ-pau.fr](mailto:tarik.kouksou@univ-pau.fr)  
M. Ahachad, ETTE, FSTT, Abdelmalek Essaadi University, Tetouan, Morocco, [mahachad@uae.ac.ma](mailto:mahachad@uae.ac.ma)

### **Overview**

Refrigerated transport is one of the most dangerous steps that can disrupt the cold chain. Controlling internal temperature and delivery times during transportation is critical for preserving and improving food quality and shelf life, as well as lowering the level of health hazard. As a result, it is critical to develop solutions to ensure the quality and safety of transported foods against temperature fluctuations, as well as to reduce the energy consumption and environmental impact of commercial refrigerated trucks. Among these solutions is the use of Phase Change Materials (PCMs) in refrigerated trucks, which is a promising solution because it ensures product quality and preserves perishable goods.

### **Methods**

This study aims to numerically investigate the aero-thermal behavior and to understand the flow mechanisms in three-dimensional configurations of a refrigerated truck (open door and closed door). For that, a CFD model was developed and validated to simulate the aerothermal behavior. Several URANS turbulence models (standard  $k-\epsilon$ , standard  $k-\omega$ , SST  $k-\omega$ ) were tested and compared with recent experimental results during cooling. Following that, a physical model was developed to investigate to study the energy performance of refrigerated trucks under two scenarios: with and without PCMs. The PCMs are encapsulated in rectangular rods and installed at the top of the container.

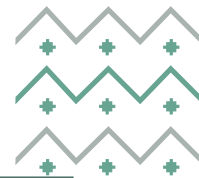
### **Results**

The results obtained show that the integration of a PCM in system can significantly reduce the cooling capacity required when the truck door is opened and lead to significant energy savings by reducing greenhouse gas emissions. Furthermore, air temperature fluctuations inside the refrigerated trucks during periods after turning off the cooling system are also reduced by using PCM. In addition, three PCMs (RT3 HC1, RT5 and RT8 HC) are tested and compared to identify the best one that guarantees the acquired temperature range. As result, the current concept using RT3 HC1, RT5, and RT8 HC proves to be capable of reducing the cooling energy required when opening the door by 61%, 57%, and 35%, respectively.

### **Conclusions**

The objective of the current thesis was to acquire knowledge about the aerothermal behavior of a refrigerated truck and to understand the flow mechanisms in various three-dimensional configurations through the employment of URANS turbulence models and conjugate heat transfer phenomena. Temperature fluctuations during loading and unloading are also significant issues in food transportation. As a result, the use of PCMs in refrigerated trucks is a promising solution for ensuring product quality and preserving perishable foods. A physical model was created to investigate the energy performance of refrigerated trucks with thermal energy storage.





## *Russia's invasion of Ukraine: medium-term implications for European and global gas markets*

Dr. Chi Kong Chyong,  
Senior Research Scholar,  
Center on Global Energy Policy,  
School of International and Public Affairs, Columbia University  
kc3634@columbia.edu

### Overview

Natural gas is an important energy source for European economies, representing roughly a quarter of total primary energy consumption (BP, 2021) and more than one-fifth of final consumption (Eurostat, 2022a). Natural gas represents one-third of all residential energy consumption, with most being used for space and water heating and cooking<sup>1</sup> (Eurostat, 2022b), while the fuel provide about 20% of energy required by power plants to generate electricity and heat. At least one-third of energy consumption in the industry comes from natural gas (both as feedstock and as a source of energy), the highest share amongst competing energy sources.<sup>2</sup>

By far, Russia is the largest gas supplier in the European Union (EU). In 2021, the country supplied ca. 40%<sup>3</sup> of all European gas import needs. On the 24<sup>th</sup> of February, 2022 Russia launched a full scale military invasion of Ukraine. Europe and its allies subsequently introduced a comprehensive set of sanctions to avert the ongoing geopolitical crisis, the worst since the WWII. For example, the United States has issued a full suspension of oil, LNG, and coal imports from Russia, while the EU has suspended all imports of coal. The European Commission has meanwhile developed plans to reduce EU dependence on Russian natural gas by two-thirds before the end of 2022, and to eliminate all dependence on Russian natural gas before 2030.<sup>4</sup>

In turn, Russia has halted exports of natural gas to Poland, Bulgaria, Finland, the Netherlands and Denmark as these countries refused to pay for gas in Rubles<sup>5</sup>, fearing that would breach sanctions imposed by the European Commission (EC). Further, recent sabotage activities blew up both Nord Stream 1 and 2 making technically (on top of politically) impossible to flow gas through these pipelines to Europe for foreseeable future. The only remaining flows from Russia are through Ukraine and Turkey, for now. The war in Ukraine, therefore, has dramatically increased the risk that Russia will unilaterally suspend all its pipeline gas exports to Europe in response to Western sanctions and the ongoing geopolitical situation.

A complete stop of Russian natural gas deliveries to Europe has turned from a theoretical and market simulation exercises (see e.g., Monforti & Szikszai, 2010; Lochner, 2011; Szikszai & Monforti, F., 2011; Chyong & Hobbs, 2014; Richter & Holz, 2015; Egging & Holz, 2016; Baltensperger et al., 2017; Bouwmeester & Oosterhaven, 2017; Deane et al., 2017; Sesini et al., 2020; Sesini et al., 2021) to a real threat to the European (and global) energy security (see e.g., statements from IEA, 2022). A full scale halt of Russian pipeline gas supplies could cause a major disruption to European energy markets, because there are limited options to replace these volumes in the short term. Consequently, in the context of Europe being highly integrated into the already tight global energy markets, a complete halt of Russian gas deliveries will have far reaching energy markets and wider macroeconomic impacts<sup>6</sup> not just in Europe, but globally.

This paper has two objectives: (i) to systematically model the impact of a full and prolonged disruption of Russian gas exports and what this means for Europe and other regions, and (ii) assess effectiveness of policy options available to mitigate the impact of this disruption. The focus of this paper is on European and global gas markets until 2030, as this time frame gives some flexibility to respond to the emerging risk of a complete halt in Russian gas supplies. Further, this time frame presents a particular interesting case study, as risk of a complete disruption of Russian gas and policy options available in this timeframe highlight challenging policy and economic trade-offs.

### Methodology

The analytical framework in this paper is grounded in scenario analysis, using a sophisticated and detailed global gas and European electricity market model. The paper advances the energy policy and modelling literature in several ways:

- (1) the model that I developed and used for this research is a co-optimized gas and electricity market model (so called "sector coupling" model). The existing literature using integrated gas and electricity models for security of supply analysis is limited (see e.g., Deane et al., 2017). Unlike Deane's et al., (2017) model, our model capture global gas markets with a detailed representation of European electricity dispatch. Moreover, I model demand side response for non-European gas markets via careful calibration of gas demand curves in the power generation sector. To our best knowledge, this is the first study to offer this level of modelling sophistication for the analysis of the implications of a prolonged disruption of Russian gas to Europe. The model, therefore, allows to capture market impacts not just for Europe, but also for the rest of global gas markets and emerging energy infrastructure investment trends.

<sup>1</sup> The role of natural gas use for home heating in the EU is diverse with Hungary and the Netherlands predominantly using gas (share of gas for gas space heating is more than 83%) while Sweden and Finland merely use gas for space heating (share of gas in space heating is less than 0.6%). At the EU level, the share of gas in space heating is 38% and in water heating - 38%, in cooking - 32% (Eurostat, 2022b). This data is quoted for the year 2020 taken from Eurostat.

<sup>2</sup> <https://www.odyssee-mure.eu/publications/efficiency-by-sector/industry/industry-eu.pdf>

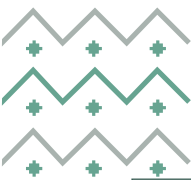
<sup>3</sup> <https://ec.europa.eu/eurostat/cache/infographs/energy/bloc-2c.html>

<sup>4</sup> [https://ec.europa.eu/commission/presscorner/detail/en/IP\\_22\\_1511](https://ec.europa.eu/commission/presscorner/detail/en/IP_22_1511)

<sup>5</sup> to partially mitigate the negative impacts of the imposed sanctions, Russia requested to be paid in Rubles, its national currency, for its gas supplies to Europe.

<sup>6</sup> Exacerbated by the already high inflation and stagnation posed by rising commodity prices





- (2) For Europe specifically, I use 35 years of hourly climate data related to temperature, wind speed, solar radiation and hydro inflows to capture inter-annual variations in gas and electricity demand and supply. This is important because the impact of a gas supply disruption will have varying intertemporal and spatial impacts, depending on realization of weather patterns across Europe as these spatiotemporal variations in weather impact not just gas demand for heating, but also renewable electricity generation. None of existing security of supply studies have these level of details in terms of input data capturing inter-annual and spatial variability of gas and electricity demand and supply.
- (3) On the demand side, our study is the first one to incorporate demand side response (DSR) from industrial gas users by explicitly accounting for the opportunity cost of gas not consumed for industrial production in Europe. Further, the paper compares the cost and benefits of industrial DSR with potential actions coming from European households willing to turn down their home thermostat in winter months. Therefore, the paper contributes to the European energy policy and regulatory debate by comparing the cost of industrial output curtailment against voluntary demand reductions by households.
- (4) Lastly, I model various proposals regarding wholesale gas price caps in Europe: (1) capping Russian gas only, (2) capping all imported gas at just below the netback cost of spot LNG imports in North East Asia. I, therefore, discuss consequences of such a cap and at what level it should be set to minimize potential market distorting effects in the short- and long-term.

The model itself is a partial equilibrium model, formulated as a quadratic programming problem in AIMMS and is solved using commercially available IBM CPLEX solver. In this regard, our modelling methodology follows a well-established energy modelling literature (see selected papers, e.g., Zwart and Mulder, 2006, Holz et al., 2008, Lise and Hobbs, 2008, Gabriel et al., 2012, Abada et al., 2013, Chyong and Hobbs, 2014, Growitsch et al., 2014).

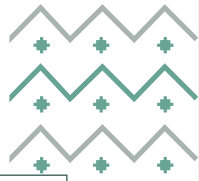
### Preliminary findings

Preliminary findings for the year 2025 suggest:

- (1) Russian gas exports to Europe is reduced by 153 bcm, relative to baseline (i.e., no disruption to gas flows). This reduction is made up of a total suspension of pipeline exports of natural gas to Europe as well as a fall in pipeline exports through Belarus. When pipeline flows are disrupted, Russia increases exports to China and Turkey, and it is able to find a route to market for some of the lost pipeline exports through an increase in LNG exports to global markets (+24 bcm). Further, global gas production is at capacity, while production in Russia falls by 64 bcm in the full disruption scenario ("shock" scenario). With the limited upside production potential, I find that the disruption causes a reduction in global gas demand (that is, demand side response fills the gap between supply and consumption). The only exception is Russia itself, which now consumes additional volumes of "stranded" (not exported) gas.
- (2) As expected, the most severe impacts on consumption are observed in Europe. In particular, the modelling results suggest that at least 61 bcm of demand reduction is required for Europe to wean itself off Russian gas in 2025. This is compared to other regions, in particular: Africa will see a reduction of gas demand by 7 bcm, South East Asia by 11 bcm and other markets by 19 bcm. Therefore, the impact of a complete halt in Russian gas exports to Europe will be felt in other regional markets too.
- (3) The reduction in gas demand in Europe of 61 bcm is split between power sector gas consumption (reduction of 40 bcm) and industrial gas consumption (reduction of 21 bcm). Thus, I find no curtailment of gas demand for households. I find that non-Russian gas (predominantly LNG) supplies amounts to 91 bcm when there is no flows from Russia.
- (4) In European electricity market, I find no electricity supply curtailment to households. The security of electricity supply to European households can be achieved mainly through fuel switching (gas to coal and oil-fired power generation). In particular, I find that coal and oil generation can provide an additional 140 TWh of supplies to Northwest Europe.
- (5) As noted already, the industrial gas demand should be reduced by 22 bcm when there are no gas flows from Russia. This industrial demand reduction is, however, not uniform across Europe: for example, I find that the most severe impacts are concentrated in Central and Eastern Europe. Thus, solidarity policy measures should be ensured to allocate scarce gas resources in case of a physical shortage of the magnitude that was modelled. This finding, in particular, highlights the importance of developing curtailment rules within and between European countries in a way that minimizes total loss of social welfare, while ensuring fairness and equity amongst consumer groups (e.g., industrial vs commercial vs households) and amongst European countries.

This is still work in progress and I aim to model the impacts across the entire time horizon – 2023-2030 to draw more immediate as well as longer-term impacts. I also aim to draw conclusions about policy measures, such as price caps in gas and electricity markets in Europe and considerations policy makers should be aware of when thinking about price caps. I also intend to analyze investments in LNG exports required to bridge the gap in the emerging gas supply due to unavailability of Russian gas exports to Europe and globally.






## References

- Abada, I., Briat, V., Gabriel, S. A. and Massol, O. (2013). "A Generalized Nash-Cournot Model for the North-Western European Natural Gas Markets with a Fuel Substitution Demand Function: The GaMMES Model," *Networks and Spatial Economics*, 13(1), pp. 1-42.
- Baltensperger, T., Füchslin, R.M., Krüttli, P. and Lygeros, J., 2017. European Union gas market development. *Energy Economics*, 66, pp.466-479.
- Bouwmeester, M.C. and Oosterhaven, J., 2017. Economic impacts of natural gas flow disruptions between Russia and the EU. *Energy policy*, 106, pp.288-297.
- Chyong, C. K. and B. F. Hobbs (2014). "Strategic Eurasian natural gas market model for energy security and policy analysis: Formulation and application to South Stream," *Energy Economics*, 44, pp. 198–211. <http://dx.doi.org/10.1016/j.eneco.2014.04.006>.
- Chyong, C.K. and Hobbs, B.F., 2014. Strategic Eurasian natural gas market model for energy security and policy analysis: Formulation and application to South Stream. *Energy Economics*, 44, pp.198-211.
- Deane, J.P., Ciaráin, M.Ó. and Gallachóir, B.Ó., 2017. An integrated gas and electricity model of the EU energy system to examine supply interruptions. *Applied Energy*, 193, pp.479-490.
- Egging, R. and Holz, F., 2016. Risks in global natural gas markets: investment, hedging and trade. *Energy Policy*, 94, pp.468-479.
- Eurostat (2022a). Energy balance flow for European Union (27 countries). Available here: <https://tinyurl.com/swttx633>.
- Eurostat (2022b). Energy consumption in households. Available here: <http://tiny.cc/5rozuz>.
- Gabriel, S. A., Rosendahl, K. E., Egging, R., Avetisyan, H. G. and Siddiqui, S. (2012). "Cartelization in gas markets: Studying the potential for a "Gas OPEC"," *Energy Economics*, 34(1), pp. 137-152. <http://doi:10.1016/j.eneco.2011.05.014>
- Growitsch, C., Heckin, H. and Panke, H. (2014). "Supply disruptions and regional price effects in a spatial oligopoly - an application to the global gas market," *Review of International Economics*, 22(5), pp. 944–975.
- Holz, F., von Hirschhausen, C. and Kemfert, C. (2008). "A strategic model of European gas supply (GASMOD)," *Energy Economics*, 30(3), pp. 766–788.
- IEA (International Energy Agency), 2022. IEA key statements and communications on the natural gas crisis in Europe. Available at: <https://www.iea.org/news/iea-key-statements-and-communications-on-the-natural-gas-crisis-in-europe>.
- Lise, W. and Hobbs, B. F. (2008). "Future evolution of the liberalised European gas market: Simulation results with a dynamic model," *Energy*, 33(7), pp. 989–1004.
- Lochner, S., 2011. Modeling the European natural gas market during the 2009 Russian–Ukrainian gas conflict: ex-post simulation and analysis. *Journal of Natural Gas Science and Engineering*, 3(1), pp.341-348.
- Monforti, F. and Szikszai, A., 2010. A MonteCarlo approach for assessing the adequacy of the European gas transmission system under supply crisis conditions. *Energy Policy*, 38(5), pp.2486-2498.
- Richter, P.M. and Holz, F., 2015. All quiet on the eastern front? Disruption scenarios of Russian natural gas supply to Europe. *Energy Policy*, 80, pp.177-189.
- Sesini, M., Giarola, S. and Hawkes, A.D., 2020. The impact of liquefied natural gas and storage on the EU natural gas infrastructure resilience. *Energy*, 209, p.118367.
- Sesini, M., Giarola, S. and Hawkes, A.D., 2021. Strategic natural gas storage coordination among EU member states in response to disruption in the trans Austria gas pipeline: A stochastic approach to solidarity. *Energy*, 235, p.121426.
- Szikszai, A. and Monforti, F., 2011. GEMFLOW: A time dependent model to assess responses to natural gas supply crises. *Energy Policy*, 39(9), pp.5129-5136.
- Zwart, G. and Mulder, M. (2006). "NATGAS: A model of the European natural gas market," CPB Memorandum 144. <http://www.cpb.nl/sites/default/files/publicaties/download/memo144.pdf>.





# **Arabic Abstracts by Subject Area**



## An experiment on Plastic waste Distillation and Plastic waste oil

### تجارب عملية في تقطير مخلفات البلاستيك وزيت مخلفات البلاستيك

د- كمال محمد حامد و اخرين جامعة نيالا – كلية العلوم الهندسية \*

\*استا مساعد دكتوراة الهندسة الكيميائية – جامعة نيالا كلية العلوم الهندسية قسم الهندسة الميكانيكية

#### مستخلص ABSTRACT

لقد أجريت تجارب عديدة في معالجة مخلفات البلاستيك Plastic Wastes عن طريق التفكك الحرارى Pyrolysis فى وجود عامل مساعد Catalyst او بدونه ذلك للحصول على طاقة او من أجل معالجة مخلفات البلاستيك التى صارت عبئاً على البيئة وملوثاً خطيراً . فى مناطق مثل أوربا وأمريكا قطعت هذه الأبحاث شوطاً كبيراً ولكن لا زالت المنطقة العربية والإفريقية تحتاج إلا مثل هذه الأبحاث والمزيد من الدراسة على الرغم من أن هناك أبحاثاً قد أجريت بكل من نجريا ومصر ركزت على معالجة مخلفات البلاستيك من اجل تقليل التلوث وخلق فرص عمل إضافية للسكان أيضاً فى المملكة العربية السعودية أجريت أبحاث على معالجة مخلفات البلاستيك من أجل تقليل التلوث وأيضاً من أجل البحث عن مصادر بديلة للطاقة وتوفير مصادر الطاقة الثمينة للنفط حتى تنسجم مع رؤية المملكة العربية السعودية للعام 2030م التى ترمى إلى تقليل الإعتماد على النفط وتطوير مصادر الطاقات البديلة . فى هذا الإطار تناقش الورقة التقنية المستخدمة فى عملية التفكك الحرارى والأدوات اللازمة لذلك كما تناقش أثر العوامل المساعدة فى عملية التفكك الحرارى لمخلفات البلاستيك كما تناقش أيضاً تحليل الزيت المستخلص من البلاستيك ومعرفة خواصه وجدوي إستخدامه كوقود فى محركات مختارة

ندى خالد السيف، سعودية، 0535588837، [nadak1ksu@gmail.com](mailto:nadak1ksu@gmail.com)

تدور الأحداث في آخر ثلاث سنوات مضت على أزمات اقتصادية متعددة منها آخر أزمة، أزمة كورونا، أدت إلى تأثر الاقتصاد بشكل كبير وخصوصا اقتصاديات الطاقة فقد تأثرت بشكل كبير بالرغم من أن الأزمات التي حدثت سابقا لم يتشافي منها الاقتصاد بشكل كامل، وبسبب أن اقتصاد الطاقة يعتبر بالسعودية القطاع الأهم بسبب أن أي دولة يعتمد نشاطها الاقتصادي على المواد الطبيعية المتاحة ويعتبر مصدر الطاقة أهم مصدر من مصادر هذه الموارد في السعودية، ولذلك فقد اهتمت المملكة العربية السعودية بهذا القطاع وقدمت الدعم اللازم لكي يزدهر وينمو بشكل كبير، ومن الأمور التي اهتمت بها المملكة العربية السعودية هي الاهتمام بالاقتصاد الأخضر وذلك من أجل الحفاظ على البيئة والصحة والموارد من الدمار، فقد كانت الطاقة المتجددة هي حجر أساسي للتنمية المستدامة فقد كان للمملكة العربية السعودية العديد من الجهود لتحقيق التنمية المستدامة من خلال رؤية ٢٠٣٠ ومحطة توليد الطاقة الشمسية المركزية وتوليد الطاقة من خلال الحرارة الأرضية .

إن الاقتصاد الأخضر هو ما يتجهه اليه العالم المتقدم بخطوات متسارعة وهو عبارة عن مشاريع تخدم البشر، ولكنها صديقة للبيئة ولا تسبب لها أضرار وهذه المشاريع تتميز بأنها عبارة عن الطاقة المتجددة بدلا عن الطاقة التقليدية التي تلوث البيئة بشكل كبير بسبب المواد التي تبعثها واستنزافها للموارد الاقتصادية، ويتميز الاقتصاد الأخضر بأنه سريع النمو ويعتمد على الطاقات المتجددة بدلا عن الوقود الأحفوري، فالطاقة المتجددة تعتمد على الموارد الطبيعية التي لا تنفذ وإنما تتجدد باستمرار مثل الرياح والشمس والمياه المتوفرة في معظم دول العالم كما يمكن انتاجها من حركة الماء او الطاقة الحرارية الأرضية ، والطاقة المتجددة تعتبر اهم عامل في الاقتصاد الأخضر بسبب كونها اقل ضرر على البيئة واقل استعمال للموارد المتوفرة في البيئة لدى البلدان ولذلك الدول المتقدمة تستثمر الكثير من أموالها في الطاقة المتجددة .

وقد وضعت الدول المتقدمة اهداف التنمية المستدامة بعين الاعتبار فاستثمارها في الاقتصاد الأخضر هي احدى مبادراتها في الدعوة على حماية الكوكب والعمل على انهاء الفقر وضمان تمتع الناس بالسلام والازدهار ، فكونهم استثمروا في الطاقة الخضراء جعلهم يقللون من التلوث في البيئة .

وما جعل الاقتصاد الأخضر يزدهر هو أهميته الاقتصادية في خلق فرص عمل لائقة وتقليل التلوث الحاصل في العديد من البلدان والمساعدة على التنمية المستدامة، وقد ساعدت في جذب العديد من المستثمرين الذين ساهموا في ازدهار هذا الاقتصاد وجعله يزدهر بين المشاريع الاقتصادية الأخرى.

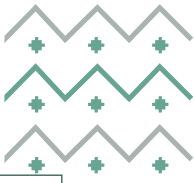
تهدف هذه الدراسة إلى تحديد وقياس أثر الاقتصاد الأخضر على التنمية المستدامة، استخدمت الدراسة المنهج الوصفي التحليلي في عرض الإطار النظري وتحليل البيانات في فترة 2021-2001م في المملكة العربية السعودية بالإضافة إلى مقارنة مستويات التلوث في المملكة العربية السعودية مع دول مجلس التعاون الخليجي، بالإضافة إلى استخدام النموذج القياسي لمعرفة أثر الاقتصاد الأخضر على التنمية المستدامة وهل أثر العمل الأخضر على العمل اللائق، وكانت المساهمة الرئيسية من هذه الدراسة هي أنها خضعت لتحليل البيانات بالإضافة إلى استخدام الأسلوب القياسي لتحليل الاقتصاد الأخضر كمتغير مستقل على التنمية المستدامة كمتغير تابع من خلال نموذج الانحدار الخطي المتعدد باستخدام طريقة المربعات الصغرى العادية على عكس بقية الدراسات السابقة فلم تنطرق إلى تحليل البيانات بشكل دقيق باستخدام الأسلوب القياسي وكانت الدراسات تعتمد على التحليل في الإطار النظري .

من المتوقع في نهاية البحث بعض النتائج والتوصيات من خلال البحث والتي استنتجتها من خلال تحليل البيانات واستخدام النموذج القياسي لمعرفة أثر الاقتصاد الأخضر على التنمية المستدامة، ومنها تلك الأسئلة التي كانت تشكل تساؤلات وهي :

- 1 - ما أثر الاقتصاد الأخضر على التنمية المستدامة؟
- 2 - ما أهمية الاقتصاد الأخضر؟
- 3 - ما جهود الحكومات في دعم الاقتصاد الأخضر؟

المراجع:

- 1 - بن علي، قريبيج، بن ناصر، سيد أحمد، وشاعة، عبد القادر. (2019). الطاقة الخضراء وتحديات تحقيق التنمية الاقتصادية الشاملة. مجلة الاستراتيجية والتنمية، مج9، عدد خاص، 218 - 234.



- 2 - نجاتي، حسام الدين (٢٠١٤)، "الاقتصاد الأخضر ودوره في تحقيق التنمية المستدامة"، سلسلة قضايا التخطيط والتنمية رقم ٢٥١، معهد التخطيط القومي، مصر، ص.١٤-١٥.
- 3 - قحام، وهيب، وشرق، سمير. (2016). الاقتصاد الأخضر لمواجهة التحديات البيئية وخلق فرص عمل: مشاريع الاقتصاد الأخضر في الجزائر. مجلة البحوث الاقتصادية والمالية، ع6، 435 - 455.
- 4 - بيكيت، فرانس. (1998). حماية البيئة الخضراء: الطاقة المتجددة ورياح التغيير. مجلة رسالة اليونسكو، س51، 38 - 40.
- 5 - بن صالح، عادل، حجاجي، محمد الأمين، وطوريش، عبد المالك. (2019). آليات تمويل الطاقة الخضراء. مجلة الاستراتيجية والتنمية، مج9، عدد خاص، 120 - 140.



## تحديات إنتاج الطاقة البحرية في الدول العربية: دراسة مقارنة

نوال علي الزهراني، جامعة الملك سعود، 0966554655852، [439200986@student.ksu.edu.sa](mailto:439200986@student.ksu.edu.sa)  
سارة ماجد المقبل، جامعة الملك سعود، 0966531918613، [441201597@student.ksu.edu.sa](mailto:441201597@student.ksu.edu.sa)

لطالما ارتبطت جودة حياة الانسان بمدى توفر المياه ولذلك نجد أن التنمية المستدامة في الدول العربية أحد أهدافها يتعلق بالمياه والصرف الصحي ومن ناحية اقتصادية توفر المياه يرتبط بتطوير عوامل أخرى وكذلك مخرجات قطاعات أخرى ولكن تكمن هنا مشكلة الدول العربية أنها تتصف بالندرة النسبية بالمياه من ناحية التضاريس والمناطق الجغرافية وأيضاً من نمو عدد السكان المتسارع والإفراط في استهلاك المياه. ونجد أن هذه الدول رغم استهلاكها الكبير من المياه إلا أنها تعتمد على الماء في اقتصاديات الزراعة والرعي وتوفرها للسكان ولكن لم يتم الاستفادة بشكل كبير من المياه في توليد الطاقة وهنا نتجه أيضاً لمشكلة أخرى تواجه الدول العربية وإحدى التحديات التي تعاني منها وهي الطاقة.

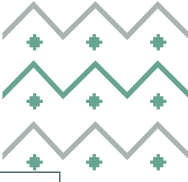
وسوف يتضح مما سبق صعوبة اعتماد الدول العربية على المياه كمصدر طاقة لأسباب عديدة سوف يتم ذكرها في البحث، ويمكن تحديد مشكلة البحث من خلال الإجابة على بعض الأسئلة المرتبطة بمدى إمكانية الاستفادة من مصادر المياه لإنتاج الطاقة دون أن يأتي ذلك بأثر سلبي على احتياجات السكان والاقتصاد بشكل عام، وتحدد مشكلة الدراسة كالتالي: ما أبرز التحديات التي تواجه الدول العربية عند محاولة استخدام تلك التقنيات؟ ما مدى كفاءة تلك المصادر؟ ماهي الدول التي تبنت استخدام وتطوير الطاقة البحرية على نمو الاقتصاد الأزرق؟

ويهدف البحث إلى تحليل مدى نجاح السبل المختلفة في إنتاج الطاقة البحرية في البلدان التي تطور أنظمة طاقة المحيطات ومنها الطاقة الموجية، وطاقة المد والجزر، وطاقة المحيطات الحرارية، مع بحث إمكانية تطبيق هذه المشاريع في المملكة العربية السعودية، وذلك باستخدام المنهج الوصفي التحليلي في الدراسة. وبالرغم من أن الطاقة البحرية متعددة ومتوفرة بشكل كبير، وأن المياه على سطح الأرض تشكل ثلاثة أرباع مساحة الكرة الأرضية، إلا أنه لم يتم تبني التقنيات الحديثة واستغلالها لتوليد الطاقة على نطاق واسع. يستهدف البحث بشكل أخص الدول العربية والنامية. المساهمة الرئيسية لهذه الدراسة هي بالتركيز على استغلال المصادر المائية (المحيطات والبحار) ومدى كفاءة هذه المصادر عند استغلالها. يقيس البحث تجارب عدة دول ومدى نجاح تلك التجارب في مساعدة تلك التقنيات المستخدمة لإنتاج هذه الطاقة في نمو الاقتصاد الأزرق مثل العديد من البلدان التي تعمل على إنتاجها وتطويرها مثل كوريا وفرنسا وإستراليا وغيرها من الدول. وتهدف الدراسة أيضاً إلى الإشارة إلى أبرز التحديات والعيوب التي تعيق الوصول إلى استخدام تلك التقنيات وإذا كانت مجدية اقتصادياً في الدول العربية والنامية أو أنها تتصف بالنضوب الاقتصادي.

المراجع:

1. Masterson, V. (2022). Wave energy: can ocean power solve the global energy crisis?. Retrieved 8 September 2022, from <https://www.weforum.org/agenda/2022/03/wave-energy-ocean-electricity-renewables>
2. Jagannathan, M. (2022). Global marine energy capacity by country 2021 | Statista. Retrieved 8 September 2022, from <https://www.statista.com/statistics/1031127/marine-energy-capacity-globally>
3. Vyas, K. (2019). The Future of Ocean Energy Conversion. Retrieved 8 September 2022, from <https://interestingengineering.com/innovation/the-future-of-ocean-energy-conversion>
4. شوقي، أ. (2022). طاقة الأمواج.. هل تحل أزمة الطاقة العالمية؟ - الطاقة. تاريخ الاطلاع: 2022/9/8  
shorturl.at/lqz59





الاستثمار المستدام: بحث حول دور الصناديق السيادية في دعم وتمويل مشاريع الطاقة  
النظيفة بين فرص النجاح وكوابحه

محمد المهدي شنين  
باحث في العلوم السياسية جامعة  
ورقلة/الجزائر

[medmahdi89@gmail.com](mailto:medmahdi89@gmail.com)

00213699198084

سلوى حامد الملا  
باحثة دكتوراة جامعة حمد بن خليفة

[Alsaw2007@hotmail.com](mailto:Alsaw2007@hotmail.com)

00 97455537737

المخلص:

فرضت مواضيع البيئة نفسها كرهان استراتيجي على دول العالم، بفعل حجم التهديدات العابرة للقطاعات التي تستتبعها، والتي تمس كل الدول بلا استثناء، وهذا بفعل نواتج الاستهلاك الجائر للموارد، ما انعكس سلبا في التغير البيئي والدفينة المناخية، علاوة على التطرف المناخي، وموجات الحر والأعاصير والجفاف، والتي أثرت على المحاصيل، وعلى مستويات التزود بالمياه الشروبة الصالحة للاستهلاك الأدمي.

يعتبر قطاع الطاقة من أبرز المجالات الاستثمارية الملوثة، والتي تساهم في الانبعاثات الكربونية، ولا يخفى أيضا أنه قطاع مدر ومربح، خاصة في ظل الطفرات النفطية المتوالية، والتي دفعت الدول الريعانية لإنشاء صناديق خاصة لإدارة هذه الثروة، والاستثمار فيها، من أجل توظيف ريعها للحد من صدمات التقلبات في أسعار الطاقة.

بناء عليه، تسعى الورقة للربط بين الاستثمار المسؤول في الطاقات المتجددة والبديلة التي تراعي أبعاد التنمية المستدامة، وتسعى للحد من التحول المناخي والتدهور البيئي، وكذلك دور صناديق الثروة باعتبارها مصدر تمويل بأصول ضخمة، تمكن من الاستثمار في مجال مستقبلي. حيث تملك هذه الصناديق مقدرات مالية تتيح لها تمويل مشاريع البحث والانجاز للتحول الطاقوي وتطوير مجال الطاقات النظيفة، وهذا كمجال استثماري مربح مستقبلا، يتيح لهذه الصناديق أن تكون السبابة فيها كقطاع حساس واستراتيجي ومربح على المدى البعيد، وأيضا باعتباره استثمارا مسؤولا يراعي حقوق الأجيال القادمة في التمتع بالموارد والبيئة.

الكلمات الافتتاحية: الاستثمار المستدام صناديق الثروة السيادية، الطاقة النظيفة، تغيير المناخ، التدهور البيئي



## دراسة تحليلية لواقع استهلاك الطاقات المتجددة في الدول العربية

د. طه بن الحبيب أستاذ الاقتصاد بجامعة قاصدي مرباح ورقلة - الجزائر 00213663382733 [Tahabenhbib@yahoo.fr](mailto:Tahabenhbib@yahoo.fr)  
د. فاطمة الزهراء بن صغير أستاذة الاقتصاد بجامعة العربي التبسي تبسة-الجزائر 00213775248227 [bs.fatimaelzahara@gmail.com](mailto:bs.fatimaelzahara@gmail.com)

### الملخص

تعد الطاقة المحرك الأساسي لأي عملية إنتاجية باعتبارها مورد استراتيجي وأن تطور العملية الإنتاجية وزيادة الإنتاج في العالم يتركز أساسا على الاستهلاك الواسع للطاقة سواء التقليدية منها أو المتجددة، لدى فقد بات لزاما على الدول تنويع المصادر الطاقوية لديها والاهتمام بالطاقات المتجددة التي يجب أن توضع ضمن الأولويات الكبرى التي وجب التركيز عليها في المستقبل، وذلك نتيجة التراجع المستمر لمصادر الطاقة الأحفورية وكثرة أثارها السلبية على البيئة، حيث أن الطاقات المتجددة صنفت كبديل عن الطاقات التقليدية الباهظة التكلفة، والمتجهة نحو الانخفاض ناهيك عن الأثر السلبية الكبيرة الناجمة عن صعوبة الاستغلال وانعكاس ذلك على طبقة الأرض.

تعددت أنواع الطاقات المتجددة التي تعتمد أساسا على المصادر المتولدة من الطبيعة كالشمس والرياح والمياه وكان لها عديد المزايا والعيوب وعديد الخصائص، وتفاوت استهلاكها بين قطاعات النشاط في الدول حيث نجدها في القطاع الصناعي والنقل والتجارة والسكن والعمران وعدة قطاعات أخرى. حسب التقارير فإن العالم اليوم قد استهلك ما يقارب نصف احتياطياته من الطاقة التقليدية (النفط، الغاز الطبيعي، الفحم الحجري،...)، وعلى الرغم من التراجع المتزايد في احتياطيات الطاقة التقليدية، إلا أن استغلال العالم للطاقات المتجددة في المستقبل القريب والمتوسط ليس مطروحا بقوة في الوقت الراهن، إذ لا تزال السياسات الطاقوية العالمية في مجال الطاقات المتجددة رهينة البحث والتطوير.

### الطريقة

من خلال هذه الورقة البحثية سنقوم بتحليل واقع استهلاك الطاقات المتجددة في الدول العربية وتحديد الأنواع الأكثر استخداما فيها والقطاعات التي تعتمد الطاقات المتجددة بقوة أكثر من غيرها وذلك من خلال الاعتماد على احصائيات السنوات الأخيرة ويتم كل ذلك بالاعتماد المنهج الوصفي من خلال تحليل واقع الطاقات المتجددة في الدول العربية واستخدام طريقتين من طرق تحليل المعطيات المتمثلة أساسا في طريقة تحليل المكونات الأساسية (PCA) وطريقة التحليل العنقودي من أجل تصنيف الدول العربية من حيث التشابه والاختلاف حسب نوع التكنولوجيا المستخدمة في الطاقات المتجددة والقطاعات التي تُعتمد فيها الطاقات المتجددة أكثر من غيرها.

### النتائج

من النتائج المتوقعة من خلال الدراسة أن هناك دول عربية اتجه فيها استهلاك الطاقات المتجددة إلى قطاع السكن والعمران أكثر من غيره وبنسب تفوق 65% وهي: تونس، جزر القمر، ليبيا، السودان، السعودية وقطر، بينما قطاع الصناعة نجد أن الجزائر وسلطنة عمان استخدمت فيه الطاقات المتجددة أكثر من غيره بنسبة تفوق 40%، في حين كل من الامارات العربية المغرب والبحرين كان قطاع التجارة هو الأكثر استخداما للطاقات المتجددة بنسبة فاقت 44%.

أما من حيث التكنولوجيا المستخدمة في الطاقات المتجددة نجد أن الطاقة الحيوية الصلبة هي الأكثر استخداما في الدول العربية خاصة في كل من تونس، المغرب، السودان، اليمن، بينما كل من الامارات العربية، الجزائر والكويت تستخدم أكثر الطاقة الشمسية، في حين نجد أن العراق تعتمد على الطاقة الكهرومائية، بينما لا تزال كل من السعودية والبحرين تعتمد على الفحم بنسبة تفوق 80%، إلا أننا نجد طاقة الرياح هي الأقل استخداما في الدول العربية ونجدها في الأردن بنسبة 25%.







# Conference Organizers

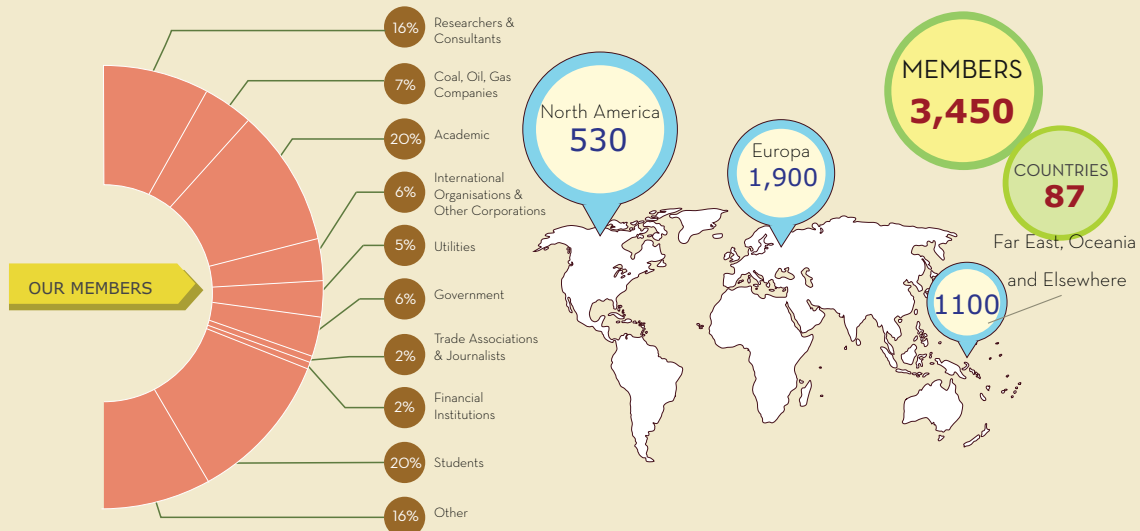
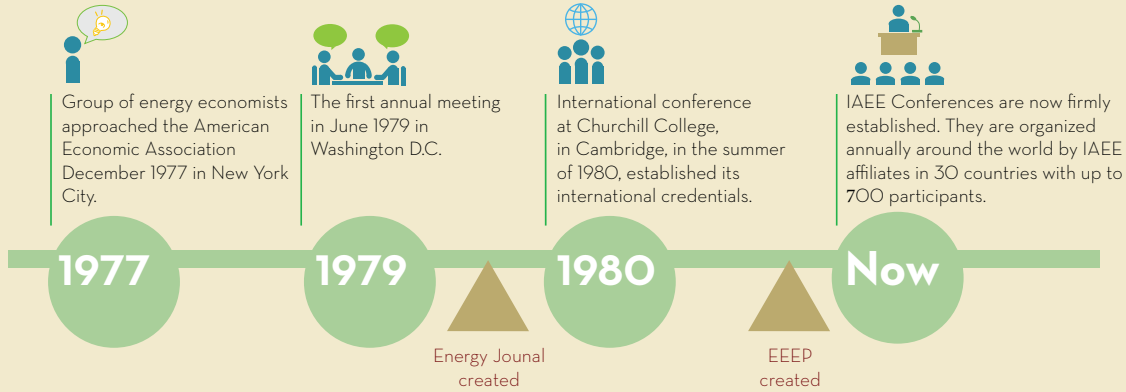


# PROCEEDINGS OF THE 44<sup>TH</sup> IAEE INTERNATIONAL CONFERENCE "PATHWAYS TO A CLEAN, STABLE, AND SUSTAINABLE ENERGY FUTURE"

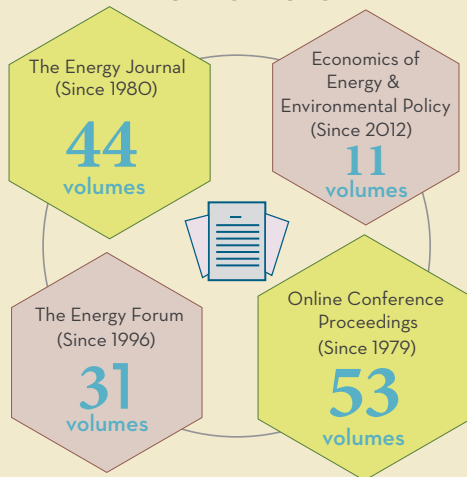


## IAEE HISTORY

We aim to provide an interdisciplinary forum for the exchange of ideas about the energy industry.



### PUBLICATIONS



### SOME MEMBERSHIP BENEFITS



WWW.IAEE.ORG



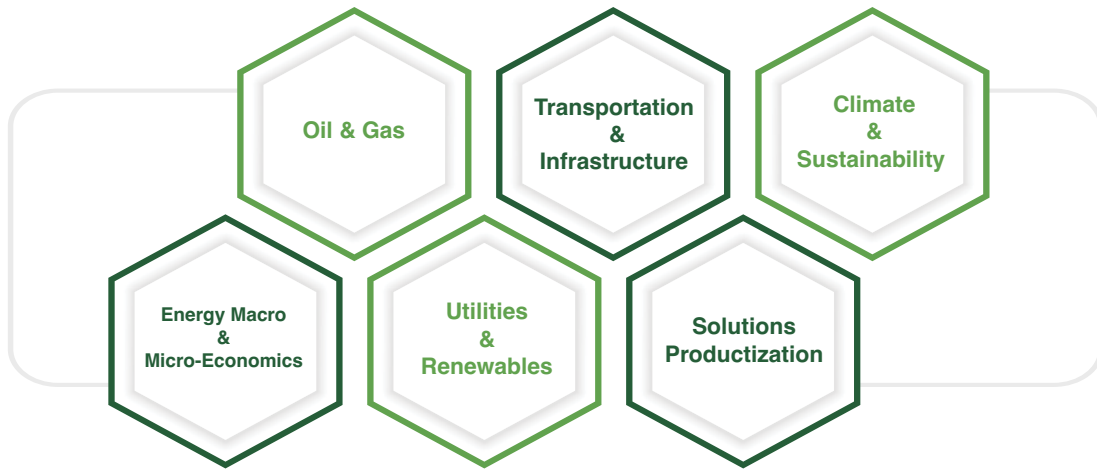
# PROCEEDINGS OF THE 44<sup>TH</sup> IAEE INTERNATIONAL CONFERENCE

"PATHWAYS TO A CLEAN, STABLE, AND SUSTAINABLE ENERGY FUTURE"



King Abdullah Petroleum Studies and Research Center (KAPSARC) is an advisory think tank within global energy economics and sustainability. Based in Riyadh, we are a community of thinkers combining human ingenuity, expertise, and research to solve pressing global energy challenges.

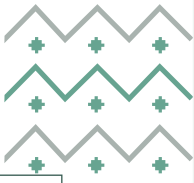
Through advisory services to the energy ecosystem, KAPSARC's experts provide actionable insights and data using a multidisciplinary approach to drive long-term value and deliver tangible results at scale across:



 <b>726+</b> Research Publications	 <b>150+</b> Workshops	 <b>151+</b> Internal Knowledge Sharing Events	 <b>270+</b> Experts
--	------------------------------	--	----------------------------

More information is available at [www.kapsarc.org](http://www.kapsarc.org)

Conference Organizers

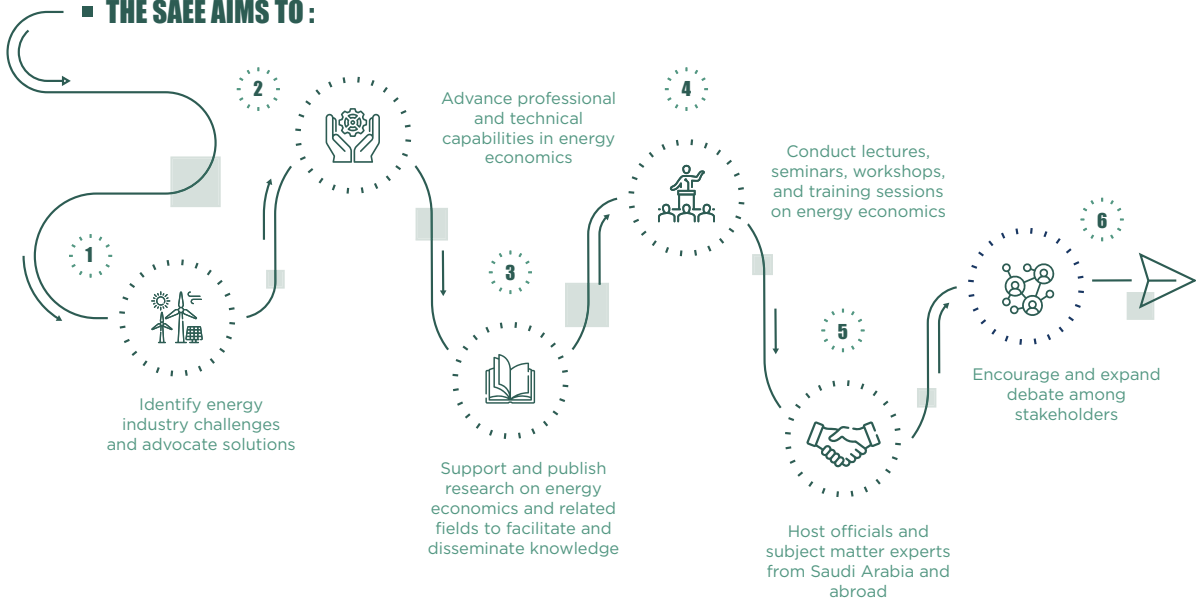


جمعية اقتصاديات الطاقة  
Saudi Association for Energy Economics

Conference Organizers

The SAAE is a non-profit civil society organization whose purpose is to promote energy economics in Saudi Arabia through events and dialogue with stakeholders in the industry. Through supporting and producing related research, the Association advances societal understanding of energy economics while enhancing professional skills in the energy industry.

THE SAAE AIMS TO :



**SEVEN**

events hosted on energy economics for the local ecosystem

**120+**

members to date

**CO-HOST**

of the 44th International Association for Energy Economics

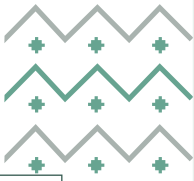
**LEAD**

proponent of the Annual MENA Energy Economics Symposium



# Conference Sponsors





Conference Sponsors

Conference Sponsors

Strategic Partner



Platinum



Gold



Bronze



Media Partners











